



UNIVERSITY OF NOVI SAD  
Technical faculty "Mihajlo Pupin"  
Zrenjanin, Republic of Serbia

In cooperation with partners

*Industrial Engineering  
and  
Environmental Protection*

**I I Z S**  
conference

PROCEEDINGS

**XI International Conference –  
Industrial Engineering And Environmental  
Protection (IIZS 2021)**

Zrenjanin, 7<sup>th</sup>-8<sup>th</sup> October 2021.



University of Novi Sad  
Technical faculty “Mihajlo Pupin”  
Zrenjanin, Republic of Serbia




# **XI International Conference - Industrial Engineering and Environmental Protection (IIZS 2021)**

Proceedings

Zrenjanin, 7 – 8<sup>th</sup>, October 2021.

IN COOPERATION WITH PARTNERS:

 <p>UP T Universitatea Politehnica Timișoara</p>	<p>UNIVERSITY POLITEHNICA TIMISOARA, FACULTY OF ENGINEERING, HUNEDOARA, ROMANIA</p>	
	<p>UNIVERSITY «St. KLIMENT OHRIDSKI», TECHNICAL FACULTY, BITOLA, MACEDONIA</p>	
	<p>„AUREL VLAICU” UNIVERSITY OF ARAD, FACULTY OF ENGINEERING, ARAD, ROMANIA</p>	
	<p>UNIVERSITY OF EAST SARAJEVO, FACULTY OF MECHANICAL ENGINEERING EAST SARAJEVO, REPUBLIC OF SRPSKA, B&amp;H</p>	
	<p>UNIVERSITY OF GIRE SUN, FACULTY OF ENGINEERING, GIRE SUN, TURKEY</p>	

# Proceedings of the XI International Conference - Industrial Engineering and Environmental Protection (IIZS 2021)

## Conference organizer:

Technical faculty "Mihajlo Pupin", Zrenjanin, University of Novi Sad, Republic of Serbia

## Reviewers:

PhD Snežana Filip, Technical Faculty "Mihajlo Pupin", Zrenjanin, Serbia  
PhD Slavica Prvulović, Technical Faculty "Mihajlo Pupin", Zrenjanin, Serbia  
PhD Ljiljana Radovanović, Technical Faculty "Mihajlo Pupin", Zrenjanin, Serbia  
PhD Bogdana Vujić, Technical Faculty "Mihajlo Pupin", Zrenjanin, Serbia  
PhD Eleonora Desnica, Technical Faculty "Mihajlo Pupin", Zrenjanin, Serbia  
PhD Vladimir Šinik, Technical Faculty "Mihajlo Pupin", Zrenjanin, Serbia  
PhD Jasmina Pekez, Technical Faculty "Mihajlo Pupin", Zrenjanin, Serbia  
PhD Višnja Mihajlović, Technical Faculty "Mihajlo Pupin", Zrenjanin, Serbia  
PhD Zoran Čepić, Faculty of Technical Sciences. Novi Sad, Serbia  
PhD Nina Đapić, Technical Faculty "Mihajlo Pupin", Zrenjanin, Serbia  
PhD Jasna Tolmač, Technical Faculty "Mihajlo Pupin", Zrenjanin, Serbia  
PhD Dejan Đorđević, Technical Faculty "Mihajlo Pupin", Zrenjanin, Serbia  
PhD Mihalj Bakator, Technical Faculty "Mihajlo Pupin", Zrenjanin, Serbia  
PhD Edit Terek Stojanović, Technical Faculty "Mihajlo Pupin", Zrenjanin, Serbia  
PhD Milija Krajišnik, Mechanical Faculty, East Sarajevo, Bosnia and Herzegovina

## Publisher:

Technical faculty "Mihajlo Pupin", Zrenjanin, University of Novi Sad, Đure Đakovića bb, 23000 Zrenjanin, Republic of Serbia

## For publisher:

PhD Dragica Radosav, Dean of Technical faculty "Mihajlo Pupin", Zrenjanin

## Technical treatment:

PhD Mića Đurđev, Technical faculty "Mihajlo Pupin", Zrenjanin, Republic of Serbia  
PhD Jasna Tolmač, Technical faculty "Mihajlo Pupin", Zrenjanin, Republic of Serbia  
MSc Borivoj Novaković, Technical faculty "Mihajlo Pupin", Zrenjanin, Republic of Serbia

---

Organization of this Conference is supported by the Ministry of Education, Science and Technological Development, Republic of Serbia

---

## CIP Classification:

CIP - Каталогизacija u publikaciji  
Biblioteka Matice srpske, Novi Sad

62:005.3(082)(0.034.4)

502/504(082)(0.034.4)

### **INTERNATIONAL Conference Industrial Engineering and Environmental Protection (11 ; 2021 ; Zrenjanin)**

Proceedings [Elektronski izvor] / XI International Conference Industrial Engineering and Environmental Protection (IIZS 2021), Zrenjanin, 7-8th October 2021. - Zrenjanin : Technical Faculty "Mihajlo Pupin", 2021. - 1 elektronski optički disk (CD-ROM) ; 12 cm

Nasl. sa naslovnog ekrana. - Str. 7: Introduction / Snežana Filip. - Bibliografija uz svaki rad.

ISBN 978-86-7672-348-5

а) Индустрijско инжењерство - Зборници б) Животна средина - Заштита - Зборници

COBISS.SR-ID 48776201

## **SCIENTIFIC COMMITTEE - TECHNICAL FACULTY „MIHAJLO PUPIN“**

PhD Snezana Filip, Technical faculty "Mihajlo Pupin", Zrenjanin, Serbia  
PhD Slavica Prvulovic, Technical faculty "Mihajlo Pupin", Zrenjanin, Serbia  
PhD Ljiljana Radovanovic, Technical faculty "Mihajlo Pupin", Zrenjanin, Serbia  
PhD Bogdana Vujic, Technical faculty "Mihajlo Pupin", Zrenjanin, Serbia  
PhD Eleonora Desnica, Technical faculty "Mihajlo Pupin", Zrenjanin, Serbia  
PhD Vladimir Sinik, Technical faculty "Mihajlo Pupin", Zrenjanin, Serbia  
PhD Jasmina Pekez, Technical faculty "Mihajlo Pupin", Zrenjanin, Serbia  
PhD Visnja Mihajlovic, Technical faculty "Mihajlo Pupin", Zrenjanin, Serbia

## **INTERNATIONAL SCIENTIFIC COMMITTEE**

PhD James G. Speight, CD&W Inc., Laramie, Wyoming, USA  
PhD Hosam E.A.F. Bayoumi Hamuda, Obuda Univerzity, Budapest, Hungary  
PhD Svetlana Lilkova, University of Architecture, Civil Engineering and Geodesy (UACEG), Faculty of Hydraulic Engineering, Sofia, Bulgaria  
PhD Dimitar G. Petrov, Technical University Sofia, branch Plovdiv, Bulgaria  
PhD Valentina Emilia Balas, „Aurel Vlaicu" University of Arad, Faculty of Engineering, Arad, Romania  
PhD Imre Kiss, University Politehnica Timisoara, Faculty of engineering, Hunedoara, Romania  
PhD Francisc Popescu, University Politehnica Timisoara, Timisoara, Romania  
PhD Mukrimin Sevkert Guney, University of Giresun, Faculty of Engineering, Giresun, Turkey  
PhD Mustafa Serkan Soylu, University of Giresun, Faculty of Engineering, Giresun, Turkey  
PhD Yalc;m Tepe, University of Giresun, Faculty of Engineering, Giresun, Turkey  
PhD Mustafa Tiirkmen, University of Giresun, Faculty of Engineering, Giresun, Turkey  
PhD Aysun Turkmen, University of Giresun, Faculty of Engineering, Giresun, Turkey  
PhD Muharrem Hilmi Aksoy, Selcuk University, Engineering Faculty, Konya, Turkey  
PhD Alexander Salnikov, Ukhta State Technical University (USTU), Ukhta, Republic of Komi, Russia  
PhD Hrvoje Glavas, Josip Juraj Strossmayer University of Osijek, Faculty of Electrical Engineering, Computer Science and Information Technology, Osijek, Croatia  
PhD Tomislav Barie, Josip Juraj Strossmayer University of Osijek, Faculty of Electrical Engineering, Computer Science and Information Technology, Osijek, Croatia  
PhD Silva Lozancic, Josip Juraj Strossmayer University of Osijek, Faculty of Civil Engineering, Osijek, Croatia  
PhD Mirko Karakasic, University of Slavonski Brod, Faculty of Mechanical Engineering Slavonski Brod, Slavonski Brod, Croatia  
PhD Vangelce Mitrevski, University «sv. Kliment Ohridski«, Technical Faculty, Bitola, Macedonia  
PhD Milija Krajsnik, University of East Sarajevo, Faculty of Mechanical Engineering, Republic of Srpska, Bosnia and Herzegovina  
PhD Mirjana Vojinovic Miloradov, professor emeritus, University of Novi Sad, Faculty of Technical Sciences, Novi Sad, Serbia  
PhD Bratislav Blagojevic, University of Nis, Faculty of Mechanical Engineering, Nis, Serbia  
PhD Blaza Stojanovic, University of Kragujevac, Faculty of Engineering, Kragujevac, Serbia  
PhD Dragan D. Milanovic, University of Belgrade, Faculty of Mechanical Engineering, Belgrade, Serbia  
PhD Mijodrag Milosevic, University of Novi Sad, Faculty of Technical Sciences, Novi Sad, Serbia  
PhD Dejan Lukic, University of Novi Sad, Faculty of Technical Sciences, Novi Sad, Serbia  
PhD Milan Rackov, University of Novi Sad, Faculty of Technical Sciences, Novi Sad, Serbia  
PhD Jasmina Radosavljevic, University of Nis, Faculty of Occupational Safety, Nis, Serbia  
PhD Amelija Dordevic, University of Nis, Faculty of Occupational Safety, Nis, Serbia  
PhD Snezana Dragicevic, University of Kragujevac, Faculty of Technical Sciences, Cacak, Serbia  
PhD Ivona Radovic, University of Belgrade, Faculty of Technology and Metallurgy, Belgrade, Serbia  
PhD Mirjana Kijevcanin, University of Belgrade, Faculty of Technology and Metallurgy, Belgrade, Serbia  
PhD Aleksandra Sretenovic, University of Belgrade, Faculty of Mechanical Engineering, Belgrade, Serbia  
PhD Aleksandra Mihailovic, University of Novi Sad, Faculty of Technical Sciences, Novi Sad, Serbia  
PhD Nebojsa Ralevic, University of Novi Sad, Faculty of Technical Sciences, Novi Sad, Serbia  
PhD Maja Petrovic, University of Novi Sad, Faculty of Technical Sciences, Novi Sad, Serbia

PhD Aleksandar Asonja, University Business Academy in Novi Sad, Faculty of Economics and Engineering Management in Novi Sad, Serbia

PhD Marina Milovanovic, University "Union - Nikola Tesla", Faculty for entrepreneurial business and real estate management, Belgrade, Serbia

PhD Jasmina Perisic, University "Union - Nikola Tesla", Faculty for entrepreneurial business and real estate management, Belgrade, Serbia

PhD Jordana Ninkov, Senior Research Associate, Institute of Field and Vegetable Crops, Novi Sad, Serbia

PhD Tamara Ivetic, Senior Research Associate, University of Novi Sad, Faculty of Sciences, Department of Physics, Novi Sad, Serbia

PhD Marko Ristic, Research Associate, Institute Mihajlo Pupin, Belgrade, Serbia

### **Organizing Committee:**

**PhD Snežana Filip, President, Technical faculty "Mihajlo Pupin", Zrenjanin, Serbia - Chairman**

PhD Ljiljana Radovanović, Technical faculty "Mihajlo Pupin", Zrenjanin, Serbia

PhD Slavica Prvulović, Technical faculty "Mihajlo Pupin", Zrenjanin, Serbia

PhD Eleonora Desnica, Technical faculty "Mihajlo Pupin", Zrenjanin, Serbia

PhD Bogdana Vujić, Technical faculty "Mihajlo Pupin", Zrenjanin, Serbia

PhD Jasmina Pekez, Technical faculty "Mihajlo Pupin", Zrenjanin, Serbia

PhD Visnja Mihajlović, Technical faculty "Mihajlo Pupin", Zrenjanin, Serbia

PhD Vladimir Šinik, Technical faculty "Mihajlo Pupin", Zrenjanin, Serbia

PhD Zoran Čepić, Faculty of Technical Sciences, Novi Sad, Serbia

PhD Jasna Tolmač, Technical faculty "Mihajlo Pupin", Zrenjanin, Serbia

PhD Mića Đurđev, Technical faculty "Mihajlo Pupin", Zrenjanin, Serbia

MSc Ivan Palinkaš, Technical faculty "Mihajlo Pupin", Zrenjanin, Serbia

MSc Una Marčeta, Technical faculty "Mihajlo Pupin", Zrenjanin, Serbia

MSc Borivoj Novaković, Technical faculty "Mihajlo Pupin", Zrenjanin, Serbia

BSc Eleonora Terečik, Technical faculty "Mihajlo Pupin", Zrenjanin, Serbia

## **Word of Thanks**

We wish to thank Ministry of Education,  
Science and Technological Development, Republic of Serbia,  
for donating financial means to  
the Conference Proceedings and organization of the  
XI International Conference -  
Industrial Engineering and Environmental Protection (IIZS 2021)

# INTRODUCTION

---

Departments of Mechanical engineering and Department of Environmental protection of Technical Faculty "Mihajlo Pupin", Zrenjanin, has organized the XI International Conference Industrial Engineering and Environmental Protection – IIZS 2021.

The topics of scientific conference «IIZS 2021», cover the fields of Industrial engineering and Environmental protection: Mechanical engineering, Energetics and process technique, Designing and maintenance, Oil and gas engineering, Health and environmental protection, Environmental management, Occupational safety and Engineering management.

The main goals of the conference are: innovation and expansion of knowledge engineers in industry and environmental protection; support to researchers in presenting the actual results of research projects, establishing new contacts with leading national and international institutions and universities; popularization of the faculty and its leading role in our society and the immediate environment, in order to attract quality young population for studying at our faculty, cooperation with other organizations, public companies and industry; initiative for collecting ideas in solving specific practical problems; interconnection and business contacts; introducing professional and business organizations with results of scientific and technical research; presentation of scientific knowledge and exchange of experiences in the field of industrial engineering.

We would like to express our gratitude to the partners of the conference – „Aurel Vlaicu” University of Arad, Faculty of engineering, Arad, Romania; University “St. Kliment Ohridski”, Technical faculty, Bitola, Macedonia; University Politehnica Timisoara, Faculty of engineering, Hunedoara, Romania; University of East Sarajevo, Faculty of mechanical engineering East Sarajevo, B&H, Republic of Srpska; University of Giresun, Faculty of engineering, Giresun, Turkey for supporting the organization of the 11<sup>th</sup> International Conference «IIZS 2021». We are also grateful to all the authors who have contributed with their papers to the organization of the scientific meeting «IIZS 2021».

We would like to extend our special thanks to the Ministry of Education, Science and Technological Development, Republic of Serbia and the management of Technical Faculty “Mihajlo Pupin”, University of Novi Sad, for supporting the organization of the Conference «IIZS 2021».

The IIZS Conference became a traditional meeting of researchers from all over the world, every year. We are open and thankful for all useful suggestions which could contribute that the next, XII International Conference - Industrial Engineering and Environmental Protection, become better in organizational and program sense.

Chairman of the Organizing Committee  
Asst. prof. Snežana Filip

Zrenjanin, 7 - 8<sup>th</sup> October 2021.



**Conference participants are from the following countries:**



Romania



Bosnia and Herzegovina



Hungary



North Macedonia



Bulgaria



Croatia



Turkey



Iran



Austria



Serbia



Portugal



Russian Federation

# CONTENTS

## PLENARY SESSION

SURFACE WATER QUALITY ON CERNA RIVER (Francisc Popescu, Milan Trumic, Bogdana Vujic, Nada Strbac, Adrian Eugen Cioabla, Vukosav Antonijevic, Carmen Radescu, Gavril Trif-Tordai).....	2
ENERGY RENOVATION OF SCHOOL BUILDINGS IN OSIJEK-BARANJA COUNTY (Držislav Vidaković, Silva Lozančić, Marijana Hadzima-Nyarko, Marija Krajnović) .....	6
EMOTIONAL INTELLIGENCE AND LEADERSHIP IN CONSTRUCTION MANAGEMENT (Nazi Ghamkhar, Ali Reza Afshari, Sanja Stanisavljev) .....	15
ENVIRONMENTAL FACTORS AND SPREADING OF COVID-19 VIRION (Hosam E.A.F. Bayoumi Hamuda) .....	25

## I - INDUSTRIAL ENGINEERING

### Session 1: Mechanical Engineering

NEW CONCEPT HAZELNUT UNSHELLING APPARATUS (Mukrimin S. Guney) .....	46
DYNAMIC STABILITY OF A FLUID-IMMERSED PIPE CONVEYING FLUID AND RESTING ON A DAMPED WINKLER ELASTIC FOUNDATION (Dimitar Lolov, Svetlana Lilkova-Markova) .....	49
ESTABLISHMENT OF WORKING UNITS IN THE MACHINE TOOLS OVERHAUL PRODUCTION SYSTEM (Bogdan Marić, Vlado Medaković).....	56
ESTABLISHING PULL SYSTEM IN ORDER MANUFACTURING – CASE STUDY (Bogdan Marić, Vlado Medaković).....	62
THE INFLUENCE OF CARBON FIBER ORIENTATION ANGLE ON BUCKLING PROPERTIES OF FOUR-LAYER SYMMETRIC LAMINATE UNDER BIAXIAL COMPRESSION (Dejan Jeremić, Nebojša Radić, Nikola Vučetić).....	70
NEWS IN INDUSTRIAL APPLICATION OF CATHODIC CAGE PLASMA NITRIDING (Željko Stojanović, Slavica Prvulović, Sanja Stanisavljev, Mila Kavalić) .....	78
APPLICATION OF HYBRID TECHNOLOGIES IN THE FUNCTION OF IMPROVING THE PERFORMANCE OF HOT FORGING TOOLS (Željko Stojanović, Slavica Prvulović, Sanja Stanisavljev, Mila Kavalić) .....	87
APPLICATION OF ISO – IEC 80000-6:2008 IN THE DESCRIPTION OF TECHNICAL SYSTEMS (Domagoj Pejakušić, Yvonne Liermann-Zeljak, Hrvoje Glavaš) .....	97
DETERMINATION OF NATURAL FREQUENCY AND AMPLITUDE RATIO OF A RAYLEIGH DOUBLE BEAM SYSTEM WITH A KEER MIDDLE LAYER SUBJECTED TO COMPRESSIVE AXIAL LOAD (Branislav Milenković, Danilo Karličić, Đorđe Jovanović) .....	103

MOLD CAVITY LAYOUT DESIGN ( <b>Ivan Matin, Branko Štrbac, Miloš Ranisavljev, Đorđe Vukelić, Miodrag Hadžistević</b> ) .....	112
VANADIUM IN TOOL STEELS ( <b>Zoran Karastojković, Jasmina Pekez, Nikola Bajić</b> ) .....	117
STUDY ON THE DRIVER ERGONOMIC POSITION INSIDE DIFFERENT TYPES OF VEHICLES ( <b>Alexandru Dumitru Antonie, Adrian Eugen Cioabla</b> ) .....	128
<b>Session 2: Energetics and Process Technique</b>	
THE DEVICE FOR THE PRODUCTION AND THE USAGE OF THE BIOGAS THROUGH THE ANAEROBIC FERMENTATION OF THE MIXTURE OF THE FRAGMENTED BIOMASS AND THE STABLE DUNG ( <b>Slavica Prvulović, Jasna Tolmač, Milica Josimović, Ivica Micić, Miloš Josimović</b> ) .....	130
ADVANTAGES OF BIOGAS POWER PLANTS IN ENERGY TRANSITION PANNONIAN COUNTRIES (1) - Benefits for the local community ( <b>Milan Ivanović, Hrvoje Glavaš</b> ) .....	138
ADVANTAGES OF BIOGAS POWER PLANTS IN ENERGY TRANSITION PANNONIAN COUNTRIES (2) - Benefits for the national economy ( <b>Milan Ivanović, Hrvoje Glavaš</b> ) .....	144
THE IMPACT OF VALID REGULATIONS ON ELECTROMAGNETIC FIELDS OF THE ERNESTINOVO SUBSTATION ( <b>Robert Noskov, Ivica Petrović, Hrvoje Glavaš</b> ) .....	150
STATISTICAL EVALUATION OF SOME FIVE PARAMETERS SORPTION ISOTHERMS MODELS ( <b>Vangelce Mitrevski, Cvetanka Mitrevska</b> ) .....	156
HEAT STORAGE FOR RESIDENTIAL SECTOR APPLIANCE ( <b>Milena Mančić, Miomir Raos, Milena Medenica, Milan Protić</b> ) .....	162
SONOMETRIC MEASUREMENTS IN AGRICULTURAL APPLICATIONS – CASE STUDY ( <b>Timotei Bogdan Bacos, Adrian Eugen Cioabla</b> ) .....	170
PROBLEMS RELATED TO THE ELECTRIC POWER SYSTEM OF WIND FARMS AND NEW TENDENCIES IN THEM ( <b>Vladimir Šinik, Željko Despotović, Branko Radović, Mića Đurđev, Miloš Josimović</b> ) .....	175
UNSUSTAINABLE DEVELOPMENT AND AGRICULTURE ( <b>Radovan Pejanović, Marijana Dukić-Mijatović, Jelena Ješić</b> ) .....	182
OPERATING MODELS FOR PV SYSTEMS IN EXISTING RESIDENTIAL BUILDING COMPLEXES IN VIENNA – CHALLENGES AND OPPORTUNITIES ( <b>Momir Tabakovic, Marlen Würfl, Eduardo Guerra, Miriam Gutleder</b> ) .....	186
COOLING TECHNOLOGIES OF DATA CENTERS ( <b>Stanko P. Stankov</b> ) .....	194
INFLUENCE OF PANEL LOCATION AND ORIENTATION ON EFFICIENCY OF PHOTOVOLTAIC POWER PLANT ( <b>Luka Đorđević, Jasmina Pekez, Borivoj Novaković, Mića Đurđev, Ivan Palinkaš, Dragana Milosavljev, Branko Markoski</b> ) .....	202

### **Session 3: Designing and Maintenance**

- DETECTION OF INDUSTRIAL FAN MOTOR BEARING FAULTING BY IMPLEMENTATION OF VIBRODIAGNOSTIC METHODS  
(Borivoj Novaković, Ljiljana Radovanović, Eleonora Desnica, Luka Đorđević, Mića Đurđev).....212
- CONDITION MONITORING AND DIAGNOSTICS OF SLIDING BEARINGS  
(Ranko Antunović, Nikola Vučetić, Eleonora Desnica, Imre Kiss).....218

### **Session 4: Oil and Gas Engineering**

- RESULTS OF EXPERIMENTAL RESEARCH OF HEAT TRANSFER COEFFICIENT THROUGH THE MAIN OIL PIPELINE  
(Jasna Tolmac, Slavica Prvulovic, Sasa Jovanovic, Milan Markovic, Dragisa Tolmac) .....226
- LABORATORY TESTING, EVALUATION AND ANALYSIS OF PORTLAND CEMENT IN OIL AND GAS WELLS  
(Milan Marković, Saša Jovanović, Jasna Tolmač, Isidora Popov) .....232

### **Session 5: Engineering Management**

- SELECTION OF CONSTRUCTION SITE MANAGER IN THE COMPANY “KRAFT PORT” DOO NOVI SAD: MULTICRITERIA APPROACH  
(Branislav Kuzmanović, Srdana Taboroši, Jelena Rajković, Siniša Mitić, Milan Nikolić).....241
- INTERNAL COMMUNICATION IN THE COMPANY “KRAFT PORT” DOO NOVI SAD  
(Branislav Kuzmanović, Jelena Rajković, Srdana Taboroši, Siniša Mitić, Milan Nikolić).....247
- THE SOCIO-ECONOMIC ASPECTS OF THE CIRCULAR ECONOMY MODEL  
(Dejan Đorđević, Dragan Čočkaló, Mihalj Bakator, Ljiljana Đorđević, Srđan Bogetić) .....253
- IMPROVING COMPETITIVENESS THROUGH TECHNOLOGICAL AND INDUSTRIAL INNOVATION  
(Dragan Čočkaló, Mihalj Bakator, Dejan Đorđević, Sanja Stanisavljev, Miloš Vorkapić).....258
- ACHIEVING SUSTAINABLE DEVELOPMENT THROUGH THE CONCEPT OF SOCIETY 5.0  
(Mihalj Bakator, Dejan Đorđević, Dragan Čočkaló, Cariša Bešić, Dragana Milosavljev).....265
- ECOLOGICAL IMPACT OF TELEWORK  
(Srdana Taboroši, Biljana Maljugić, Aleksandra Kovačević).....270
- ANALYSIS OF OPPORTUNITIES FOR PRODUCTIVITY IMPROVEMENT OF DOMESTIC ENTERPRISES  
(Biljana Maljugić, Srdana Taboroši) .....274
- ANALYSIS OF THE APPLICATION OF INTERNATIONAL STANDARDS IN BUSINESS PRACTICE  
(Biljana Maljugić, Marija Matotek Andelić) .....282
- PRODUCTION FLOW DIAGRAM OF PLEATED BLINDS  
(Dijana Tadić, Maja Knežević) .....290
- THE COMPARATIVE ANALYSIS REGARDING THE URBAN TRANSPORT TIMISOARA – LISBON THROUGH THE FASHION OF LINEAR  
(Patrick Stefanescu, Luisa Izabel Dungan) .....298

CONSTRUCTION CLAIM MANAGEMENT (Ali Reza Afshari, Edit Terek Stojanović, Ali Shieh Ali).....	306
SOCIAL RESPONSIBILITY AND SUSTAINABLE DEVELOPMENT (Radmila Čokorilo, Cariša Bešić, Snežana Bešić) .....	314
CONSTRUCTION SAFETY MANAGEMENT (Ali Reza Afshari, Dragica Radosav, Elaheh Tavakolian).....	319

## II – ENVIRONMENTAL ENGINEERING

### Session 6: Health and Environmental protection

TECHNOLOGICAL PROCESSES OF COMPOSTING IN A PUBLIC UTILITY COMPANY (PUC) CITY GREENERY CACAK (Dragan Nikolić, Srećko Ćurčić, Mirjana Đoković).....	328
DETERMINATION OF ADR TRANSPORT CONDITIONS APPLICABLE TO METHYL TERT- BUTYL ETHER AS A LIQUID FLAMMABLE PETROCHEMICAL (Matilda Lazić, Miodrag Kovačević) .....	334
RID CARRIAGE CONDITIONS OF FLAMMABLE LIQUID, N.O.S. (Matilda Lazić, Miodrag Kovačević, James G. Speight, Ljiljana Radovanović).....	340
MICROPLASTICS AND IMPLICATION ON HEALTH BY USING FACE MASKS DURING THE COVID – 19 PANDEMIC (Snežana Filip, Bogdana Vujić, Una Marčeta, Eleonora Terečik).....	347
IDENTIFYING METHOD OF MANAGING MEDICAL WASTE DURING THE PANDEMIC OF COVID-19 (Eleonora Terečik, Višnja Mihajlović, Una Marčeta, Marko Jovanov).....	352
POLLUTANT EMISSIONS FROM FOSSIL FUEL COMBUSTION USED FOR ACHIEVING THERMAL COMFORT IN DETACHED RESIDENTIAL BUILDINGS (Amelija Đorđević, Ana Vukadinović, Jasmina Radosavljević, Bogdana Vujić) .....	355
IMPACT OF GREEN ROOFING ON THE ENERGY PERFORMANCE OF A DETACHED PASSIVE RESIDENTIAL BUILDING WITH A TROMBE WALL (Ana Vukadinović, Jasmina Radosavljević, Amelija Đorđević).....	362
DEVELOPMENT OF HEAT LOAD PREDICTIVE MODELS IN DISTRICT HEATING SYSTEMS USING THE BOOSTING METHOD (Milan Protić, Miomir Raos, Nikola Mišić, Jasmina Radosavljević, Lidija Milošević) .....	368
ELIMINATION LEAN WASTE IN THE PRODUCTION PROCESS (Ranka Gojković, Slaviša Moljević, Bogdan Marić, Vlado Medaković) .....	375
AIR POLLUTION FROM SOLID PARTICLES, FILTRATION AND FILTERS (Milena Medenica, Miomir Raos, Milan Protić, Milena Mančić) .....	381
DECOMPOSITION OF SELECTED PHARMACEUTICAL MICROPOLLUTANTS BY NEWLY SYNTHESIZED NANOMATERIAL (Mladenka Novaković, Dragana Štrbac, Maja Petrović, Boris Obrovski, Goran Štrbac, Ivana Mihajlović) .....	389

ADSORPTION KINETICS OF 3-(4-METHYLBENZYLIDENE) CAMPHOR ON MICROPLASTICS IN WATER (Maja Vujić, Aleksandra Tubić, Vasiljević Sanja, Jelena Molnar Jazić, Tajana Simetić, Malcolm Watson, Jasmina Agbaba) .....	394
COMPARISON OF SURFACE WATER QUALITY BETWEEN CROSS-BORDER PROTECTED AREAS IN SERBIA AND CROATIA (Boris Obrovski, Mirjana Vojinović Miloradov, Maja Sremački, Mladenka Novaković, Nevena Živančev, Maja Petrović, Ivana Mihajlović).....	400
EFFECTS OF ENVIRONMENTAL POLLUTION DUE TO LAND TRANSPORT ACTIVITY (Luisa Izabel Dungan, Adrian Eugen Cioabla, Mircea Adrian Dungan, Mariana Nela Stefanut, Francisc Popescu) .....	406
WASTEWATER MANAGEMENT: A STRENGTH OR WEAKNESS OF THE REPUBLIC OF SERBIA ON THE PATH TO THE EU? (Aleksandra Sitarević, Aleksandar Sofić) .....	412
COMPOSTING OF WASTE WATER SLUDGE FROM TEXTILE INDUSTRY (Marko Rokvić, Dejan Ubavin, Maja Sremački, Milan Milotić, Zoran Čepić) .....	419
ASSESSMENT OF MUNICIPAL SOLID WASTE GENERATION IN THE MUNICIPALITIES OF AVEIRO DISTRICT USING ANOVA (ONE WAY) ANALYSIS (Nikola Karanovic) .....	423
HEALTH AND SAFETY RISKS AND CHALLENGES FOR WORKERS IN THE TONER CARTRIDGE RECYCLING PROCES (Stepan Polygalov, Marko Rokvić, Nemanja Stanisavljević, Maja Sremački, Zoran Čepić).....	429
BIOLOGICAL HAZARDS IN THE WORKING ENVIRONMENT DURING THE OPERATION OF THE ANIMAL WASTE INCINERATOR (Galina Ilinykh, Sandra Kozomora Subotin, Nemanja Stanisavljavić, Maja Sremački, Zoran Čepić) .....	434
SAFETY AND HEALTH RISKS FOR WORKERS AT THE ANIMAL WASTE INCINERATION PLANT (Sandra Kozomora Subotin, Stepan Polygalov, Nemanja Stanisavljavić, Maja Sremački, Zoran Čepić) .....	442
IDENTIFICATION AND SIGNIFICANCE OF GRAM-NEGATIVE BACTERIA IN MSW LANDFILL LEACHATE FROM VOJVODINA REGION (Katarina Antić, Zoran Čepić, Milena Stošić, Jelena Radonić) .....	450
RELATIONSHIP BETWEEN AIR QUALITY AND DISTRIBUTION OF LICHENS AS BIOINDICATORS IN SOME SERBIAN LOCATIONS (Doris Stojilkovic, Bogdana Vujic, Hosam E.A.F. Bayoumi Hamuda) .....	458
BIOINDICATION OF AIR QUALITY USING LICHEN IN ULAANBAATAR, MONGOLIA (Tsend-Ayush Erdenejargal, Enkhtuya Ochirbat, Hosam E.A.F. Bayoumi Hamuda).....	467
BIG DATA IN WATER SUPPLY AND SEWERAGE SYSTEMS (Stanko P. Stankov) .....	474

PHENOLIC PROFILE DETERMINATION OF FRUŠKA GORA POMACES FOR UTILIZATION PURPOSES

(Diandra Pintać, Ljilja Torović, Dejan Orčić, Dejana Bajić, Branko Markoski, Neda Mimica-Dukić, Marija Lesjak) .....482

STATISTICAL ANALYSIS OF DATA OBTAINED BY MEASURING AIR QUALITY AT CHILDREN'S PLAYGROUNDS IN NOVI SAD

(Nebojša M. Ralević, Jelena S. Kiurski, Ladin Gostimirović, Aleksandra Mihailović) .....486

HAZARDS AND HARMS FROM USING CHEMICAL SUBSTANCES

(Jasmina Rajić, Aleksandar Šotić, Barbara Vidaković Ristić, Dragana Paunović, Tanja Petrović) .....495

## **Session 7: Environmental Management**

GREEN HUMAN RESOURCES MANAGEMENT AND ENVIRONMENTAL PROTECTION

(Dragana Milosavljev, Edit Terek Stojanović, Mila Kavalić, Maja Gaborov, Mihalj Bakator) .....502

CIRCULAR ECONOMY PRINCIPLES IN THE HAZARDOUS WASTE PACKAGING MANAGEMENT

(Marko Rokvić, Galina Ilinykh, Nemanja Stanisavljević, Maja Sremački, Zoran Čepić) .....509

THE ROLE OF TYPE II ENVIRONMENTAL LABELS IN CIRCULAR PACKAGING

(Milana Ilić Mićunović, Tamara Novaković, Zoran Čepić, Boris Agarski, Zorica Mirosavljević) .....515

## **Session 8: Occupational Safety**

DECISION ANALYSIS AND APPLICATION OF THE DELPHI METHOD IN THE SELECTION OF EMPLOYEE EDUCATION IN THE FORMATION OF THE INVESTMENT PROJECT

(Aleksandra Kovačević) .....522

STRENGTHENING THE CAPACITIES OF OSH IN THE DEFENSE AND SECURITY TRADE UNION (SOB) IN THE REPUBLIC OF NORTH MACEDONIA

(Monika Lutovska, Vladimir Mijakovski) .....532

STATISTICAL INDICATORS FOR ACCIDENTS AT WORK IN CONSTRUCTION SECTOR

(Cvetanka Mitrevska, Elena Mitrevska, Vangelce Mitrevski) .....539

IMPROVING WORKPLACE SAFETY USING ADVANCED INDUSTRY 4.0 TECHNOLOGIES

(Marija Savković, Marica Dašić, Marko Đapan, Arso Vukićević, Ivan Mačužić, Miladin Stefanović) .....545

DEVELOPMENT OF RISK MANAGEMENT PROCESS IN INDUSTRY

(Milica Josimovic, Milos Josimovic, Slavica Prvulovic) .....553

STABLE INSTALLATIONS FOR FIRE PROTECTION ON THE FACILITY OF THE PRIMARY SCHOOL "STANČIĆ MILAN - UČA", KUMANE

(Dragana Milosavljev, Edit Terek, Borivoj Novaković, Maja Gaborov) .....558



**XI International Conference Industrial  
Engineering and Environmental  
Protection 2021 (IIZS 2021)  
October 07-08, 2021, Zrenjanin, Serbia**

---

# **Plenary Session**



## SURFACE WATER QUALITY ON CERNA RIVER

Francisc Popescu<sup>1</sup>, Milan Trumic<sup>2</sup>, Bogdana Vujic<sup>3</sup>, Nada Strbac<sup>2</sup>, Adrian Eugen Cioabla<sup>1</sup>, Vukosav Antonijevic<sup>4</sup>, Carmen Radescu<sup>5</sup>, Gavrilă Trif-Tordai<sup>1</sup>,

<sup>1</sup>University Politehnica Timisoara, Faculty of Mechanical Engineering, Timisoara, Romania

<sup>2</sup>University of Belgrade, Technical Faculty in Bor, Bor, Serbia

<sup>3</sup>University of NoviSad, Technical Faculty “Mihajlo Pupin” Zrenjanin, Zrenjanin, Serbia

<sup>4</sup>NGO “Village” Movement for developing Estern Serbia, Bor, Serbia

<sup>5</sup>ProMehedinti Association, Drobeta-Turnu Severin, Romania

e-mail: [francisc.popescu@upt.ro](mailto:francisc.popescu@upt.ro)

**Abstract:** The paper presents the results obtained during implementation of a research project coordinated by two relevant education and research Balkan institutions, University Politehnica Timisoara and University of Belgrade, project financed thru Interreg IPA-CBC Romania-Serbia programme.

The project teams performed extensive evaluation of environmental current situation in cross border “sister” Danube banks nature reservation Djerdap (Serbia) and national parks Iron Gate (Romania), and on several Danube tributaries and two wet lands: Carska-Bara special nature reserve and Delta Nera nature reservation. This paper presents in detail the results obtained for surface water quality analysis on Cerna River, the hart of nature protected area of national park Domogled – Cerna Valley, in Southern Carpatians.

**Key words:** Surface water quality, heavy metals, Cerna

### INTRODUCTION

Cerna River flows thru The Domogled-Valea Cernei National Park is a protected area (national park category II IUCN) situated in Romania, on the administrative territory of counties Caras-Severin, Gorj and Mehedinti. The National Park stretches across over the Cerna Mountains and the Godeanu Mountains on the right side, and over the Valcan Mountains and the Medinti Mountains on the left side. It is located in the Retezat-Godeanu Mountains group, a group of mountains in the Southern Carpathians, in the Cerna River basin. Domogled-Valea Cernei National Park, with an area of 61211 ha was declared protected area by Law Number 5 of March 6, 2000 and represents a mountainous area what shelters a large variety of flora and fauna, some of the species very rarely or endemics. [1]

During the past decade, after communism fall in 1989 in Romania, national natural resources in faced a lack of protection and/or enforcement of protective rules. This started to change in early 2000’s after constant NGO’s endorsement and awareness activities, and the protection of natural areas became significant since Romania became part of EU. EU water policy has successfully contributed to water protection over the past three decades. Pollution from urban, industrial and agricultural sources is regulated and this has brought about significant improvements in the quality of European waters, particularly by reducing an excess of nutrients. As a result, iconic fish species such as salmon and sturgeon have, in some places, returned to European rivers. [2]

As a sensitive topic, our team analyzed in 2020 the surface water quality on Danube (in Iron Gate / Djerdap national park’s) area and Danube’s main tributaries in this area: Nera, Pek, Porecka, Cerna and Berzasca. In this paper the obtained on Cerna river are presented.

### MATERIALS AND METHODS

Sampling is a vital part of monitoring the quality of water. Every precaution must be taken to ensure that the sample collected is as representative as is feasible of the water source or process being examined.

The in-situ analysis (for pH, temp, total hardness and dissolved oxygen) were performed on site. All samples were preserved in-situ for laboratory analysis with acids: HNO<sub>3</sub> (nitric acid) for metal concentration analysis on ZEE nit 700P, H<sub>3</sub>PO<sub>4</sub> (phosphoric acid) for Total Nitrogen analysis on

Analytik Jena Multi N/C 3100 and H<sub>2</sub>SO<sub>4</sub> (sulfuric acid) for Chemical Oxygen Demand analysis on Velp Eco6 and ammonia, phosphor, nitrite, nitrate, phosphate, a.o. on Analytik Jena Specord 250plus. All samples taken were analyzed in-situ or at the end of the sampling day. Surface water sampling on Cerna River was conducted in 19 October 2020 in 6 sampling points/locations upstream river. Samples were analysed in situ or preserved for laboratory analysis. In figure 1 the sampling points coding and geographical position can be observed.



Fig. 2. Sampling points for water quality analysis on Cerna River.

## RESULTS AND DISCUSSION

The results obtained from sampling campaigns, in 19 October 2020 are given in Tables 1.

Table 1. Results obtained for parameter analysis in samples of Cerna, on 19th October 2020

Parameter	Unit	Measured values – 19 <sup>th</sup> October 2020						Eco state
		C1	C2	C3	C4	C5	C6	
pH	-	7.34	7.33	7.38	7.42	7.38	7.31	-
Conductivity	μS/cm	372	394	388	389	378	377	-
<b>Oxygen concentration</b>								
Dissolved oxygen (DO)	mgO <sub>2</sub> /l	5.7	6.8	9.9	10.1	10.5	10.2	I <sup>st</sup> – II <sup>nd</sup>
Biochemical oxygen demand (BOD – CBO5)	mgO <sub>2</sub> /l	7.4	6.5	3.1	2.3	2.2	2.2	I <sup>st</sup> – III <sup>rd</sup>
Chemical oxygen demand (COD – CCO-Cr)	mgO <sub>2</sub> /l	18.1	16.5	8.4	7.2	6.9	6.9	I <sup>st</sup> – II <sup>nd</sup>
<b>Nutrients and general ions concentrations</b>								
Sodium (Na <sup>+</sup> )	mg/l	3.6	3.2	3.2	3.5	3.4	3.4	I <sup>st</sup>
Calcium (Ca <sup>2+</sup> )	mg/l	41.2	38.9	39.1	29.8	33.4	27.9	I <sup>st</sup>
Ammonia (NH <sub>4</sub> <sup>+</sup> )	mg/l	0.74	0.65	0.11	0.09	0.07	0.09	I <sup>st</sup> – II <sup>nd</sup>
Nitrates (NO <sub>3</sub> <sup>-</sup> )	mg/l	0.34	0.33	0.22	0.14	0.12	0.12	I <sup>st</sup>
Nitrites (NO <sub>2</sub> <sup>-</sup> )	mg/l	0.028	0.028	0.017	0.012	0.014	0.014	I <sup>st</sup>
Orto phosphate (P-PO <sub>4</sub> <sup>3-</sup> )	mg/l	0.09	0.08	0.06	0.06	0.06	0.05	I <sup>st</sup>
Sulphates (SO <sub>4</sub> <sup>2-</sup> )	mg/l	37.2	40.5	34.1	22.4	5.4	4.8	I <sup>st</sup>
Chloride (Cl <sup>-</sup> )	mg/l	0.6	0.6	0.3	0.2	0.2	0.2	I <sup>st</sup>
Total Nitrogen (TN)	mg/l	0.89	0.77	0.54	0.52	0.49	0.51	I <sup>st</sup>
<b>Heavy Metals concentrations</b>								
Mercury (Hg)	μg/l	0.030	0.026	0.015	0.011	0.014	0.011	I <sup>st</sup>
Arsenic (As <sub>3</sub> <sup>+</sup> )	μg/l	0.088	0.087	0.087	0.088	0.086	0.079	I <sup>st</sup>
Lead (Pb)	μg/l	0.054	0.016	0.018	0.014	0.016	0.017	I <sup>st</sup>
Zinc (Zn <sup>2+</sup> )	μg/l	12.1	12.8	10.1	8.9	8.8	7.5	I <sup>st</sup>
Cadmium (Cd)	μg/l	0.007	0.005	0.006	0.005	0.005	0.006	I <sup>st</sup>
Manganese (Mn - total)	mg/l	0.057	0.061	0.055	0.049	0.051	0.032	II <sup>nd</sup>
Iron (Fe – total)	mg/l	0.462	0.511	0.499	0.397	0.421	0.394	II <sup>nd</sup>

In the next figures graphical representation of results obtained on surface water analysis on Cerna River are presented.

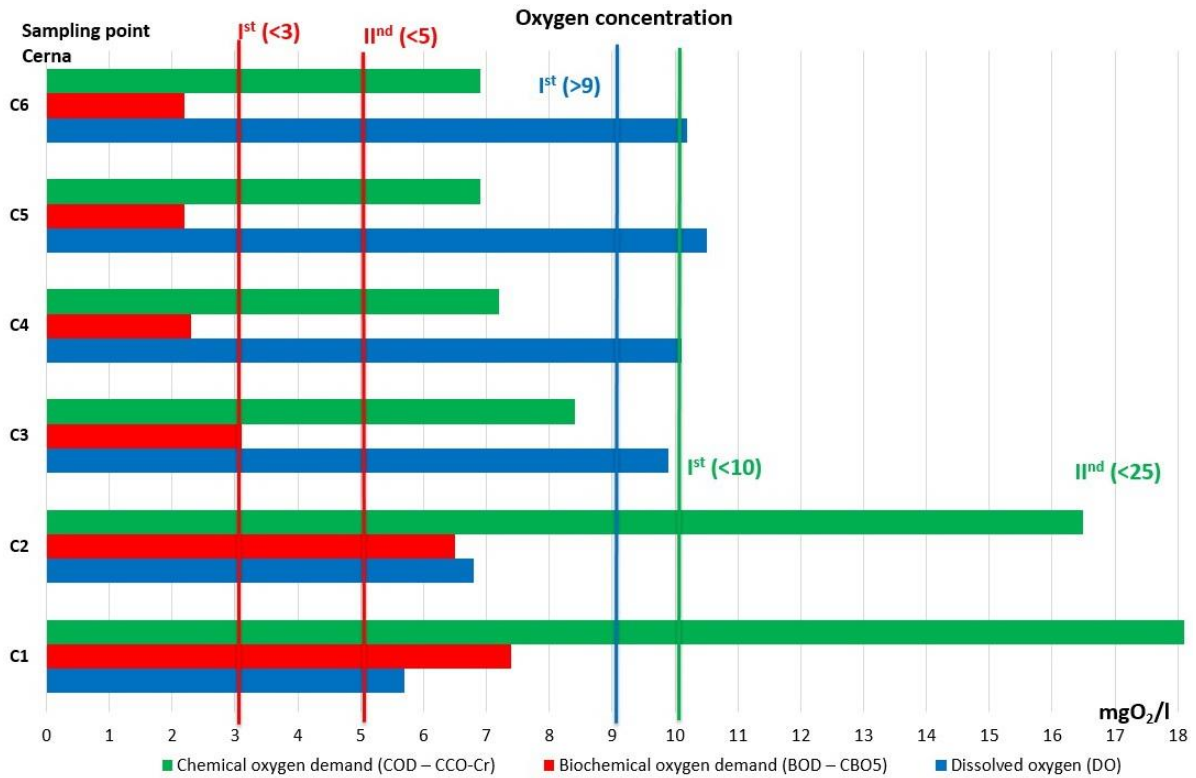


Fig. 3. Cerna River. Concentrations obtained for DO, COD and BOD5.

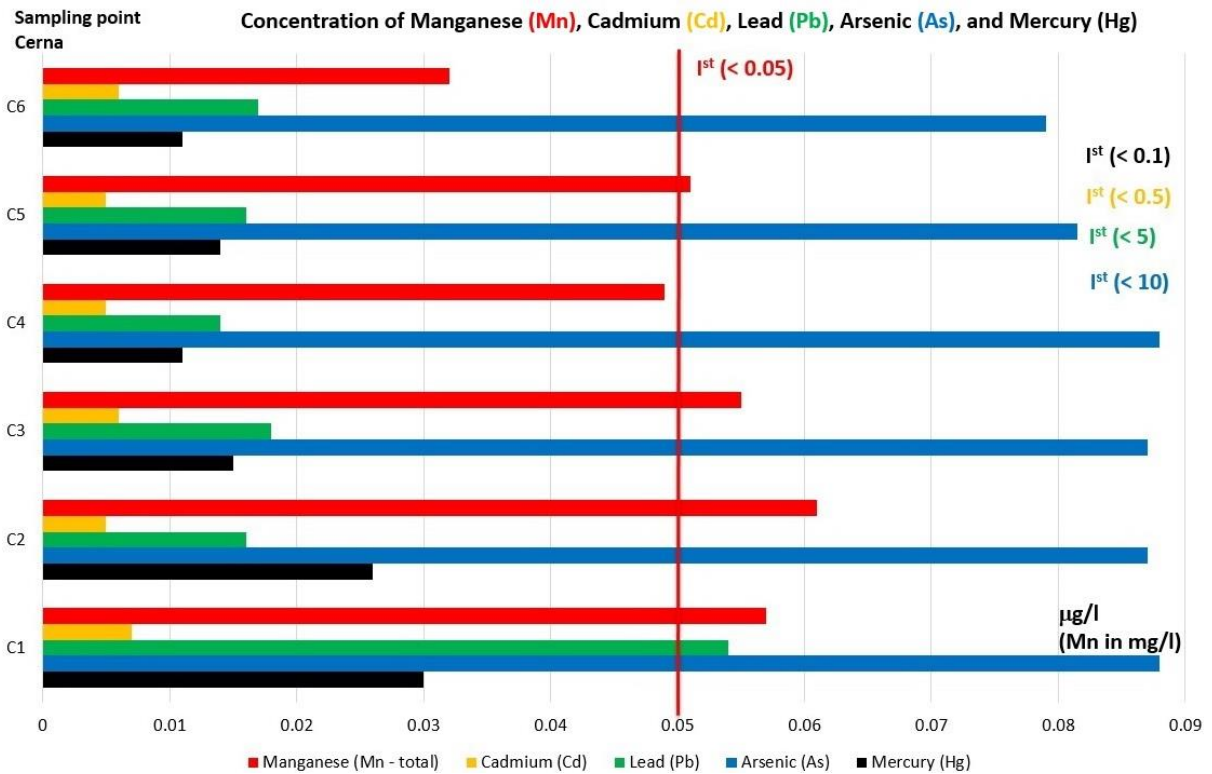


Fig. 4. Cerna River. Concentrations obtained for Mn, Cd, Pb, As and Hg.

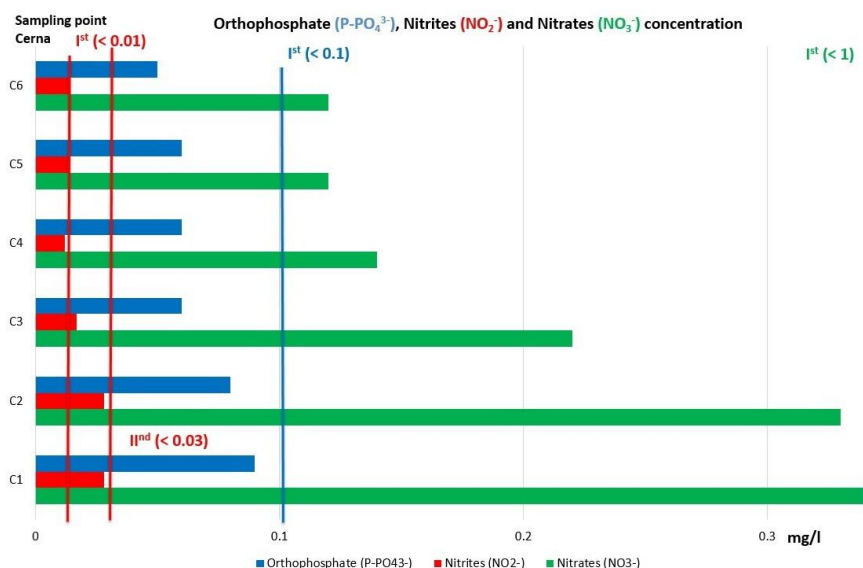


Fig. 5. Cerna River. Concentrations obtained for P-PO<sub>4</sub><sup>3-</sup>, NO<sub>2</sub><sup>-</sup> and NO<sub>3</sub><sup>-</sup>.

In terms of water quality Cerna River can be considered a “text book” river. In its upper (wilder) part all analyzed parameters (dissolved oxygen, biological oxygen demand, chemical oxygen demand, nitrites, nitrates, ammonia, phosphates, and total nitrogen) were all in I<sup>st</sup> class, HIGH water quality. However, after Cerna passes first human settlements, Baile Herculane, Toplita and gets tributary from Belareca river, on its last ~20 km the water quality decreases dramatically, “transforming” itself into GOOD/MODERATE quality river.

## CONCLUSION

The surface water quality of Cerna river can be classified as HIGH -quality in its upper side (largest portion of river while it’s quality decreases immediately as the Cerna river passes thru Baile Herculane city and becomes MODERATE.

The main stresses identified on Cerna river are from Baile Herculane city and Barza and Toplet villages waste waters, as not all houses are connected to the waste water system, contributing to pollution of surface waters.

## AKNOWLEDGMENT

This research was conducted in the frame of AEPS project, “Academic Environmental Protection Studies on surface water quality in significant cross-border nature reservations Djerdap / Iron Gate national park and Carska Bara special nature reserve, with population awareness raising workshops”, financed thru INTERREG IPA-CBC Romania-Serbia programme, project RORS-462, [www.aeps.upt.ro](http://www.aeps.upt.ro)

## REFERENCES

- [1] \*\*\*, [www.romaniaturistica.ro/parcul-national-domogled-valea-cernei](http://www.romaniaturistica.ro/parcul-national-domogled-valea-cernei)
- [2] COM 673/2012, Communication from the Commission to the European Parliament, the Council, the European economic and social committee and the Committee of the regions - A Blueprint to Safeguard Europe's Water Resources, 2012
- [3] Popescu F., Trumic, M., Laza, I., Vujic, B., Stoica V., Trumic Maja, Strbac, N., Utu, D., Antonjievic, M., Lelea, D., Radescu, C., Dosevska, S., Study on surface water quality in Djerdap/Iron Gate protected area, e-book ISBN 978-973-0-33702-0, Timisoara, Romania

## ENERGY RENOVATION OF SCHOOL BUILDINGS IN OSIJEK- BARANJA COUNTY

**Držislav Vidaković<sup>1</sup>, Silva Lozančić<sup>1</sup>, Marijana Hadzima-Nyarko<sup>1</sup>, Marija Krajnović<sup>1</sup>**

<sup>1</sup>Josip Juraj Strossmayer University of Osijek, Faculty of Civil Engineering and Architecture  
Osijek, Osijek, Croatia  
e-mail: [dvidak@gfos.hr](mailto:dvidak@gfos.hr)

**Abstract:** The paper explains the need for energy renovation of public and other buildings and the regulatory framework (regulations and program procedures) through which this is sought. Important parameters of energy renovation of 48 school buildings in Osijek-Baranja County were processed and analyzed in more detail within the projects contracted in 2017 and 2018 (co-financed from the European Structural and Investment Funds within the Operational Program "Competitiveness and Cohesion" 2014–2020). The content of energy renovation works and their frequency in buildings and the expected energy savings were presented. The representation of existing energy classes and their improvement after reconstruction, regarding the construction period were analysed. The costs of renovation in relation to the age and area of buildings were considered as well. These data were compared to the results from the previous cycle of family houses' renovation in the same county (2015–2016), while the owners were co-financed, without the required minimum of improvement. The problems of the energy renewal process were highlighted and recommendations for better efficiency were given.

**Key words** energy savings, school buildings, energy classes, renovation costs, incentive programs.

### INTRODUCTION

Energy consumption saving in the EU of 20% by 2020 and 32.5% by 2030 is being planned, and various operational programs are being implemented at EU and Member State level to achieve this.

Energy efficiency means the usage of a smaller amount of energy consumed for the same level of economic activity or service. It is considered that by investing in energy efficiency a better economic and social return are achieved than by investing in energy supply [1]. Except reduced energy costs, better energy efficiency reduces dependence on energy imports and achieves lower greenhouse gas (CO<sub>2</sub>) emissions and better air quality.

People spend most of their time in buildings and the largest share of energy consumption in the EU, as well as in Croatia, is related to buildings (part of the so-called general consumption), [1, 2, 3]. Bazan-Krzywoszanska et al. (2016) investigated energy consumption in Eastern European cities and found that it was mostly generated in residential and public buildings, [4]. The biggest aspirations are to save energy, as well as to reduce carbon emissions [5], so they are aimed at the construction of new buildings and measures that can be taken on existing ones. In Croatia, and in the rest of Europe, most residential and non-residential buildings are more than 30 years old, so the incentive programmes are focused on improving the energy efficiency of existing buildings. One should bear in mind that in buildings, regardless of their purpose, over 50% of energy is spent on heating (with which carbon emissions are mostly associated, [6]), hot water preparation and lighting (in households there is a higher share of energy consumption for heating and hot water preparation, while in public buildings for lighting), [7].

In addition to possible savings, it is necessary to calculate the costs of implementing measures to improve energy efficiency, which is different for each building. Peculiarities arise from the purpose of the space and construction solution (dispersed layout solutions, number of storeys, type of walls and roof, heating system, etc.) and the condition of the building, or its maintenance (how worn out the existing elements of the building are and when they need to be replaced).

### LEGISLATION AND INCENTIVES FOR ENERGY RENEWAL

Legislation in Croatia is in line with legislation governing obligations to improve the energy efficiency of buildings at the EU level. According to the Directive on energy performance on buildings 2010/31 / EU (EPBD) and Directive on energy efficiency 2012/27 / EU (EED), each Member State establishes a system of energy efficiency obligations and a long-term strategy to encourage investment in the

reconstruction of the national stock of residential and commercial buildings, both public and private. To encourage the renovation of energy-inefficient public buildings, which should serve as an example to the general public, the EPBD requires states to ensure that 3% of the total floor area of heated/cooled buildings in a possession and use of the central government is renovated every year from 2014, [8].

Increasing energy efficiency of residential and public buildings is achieved through the prescribing of legal obligations and financial incentives.

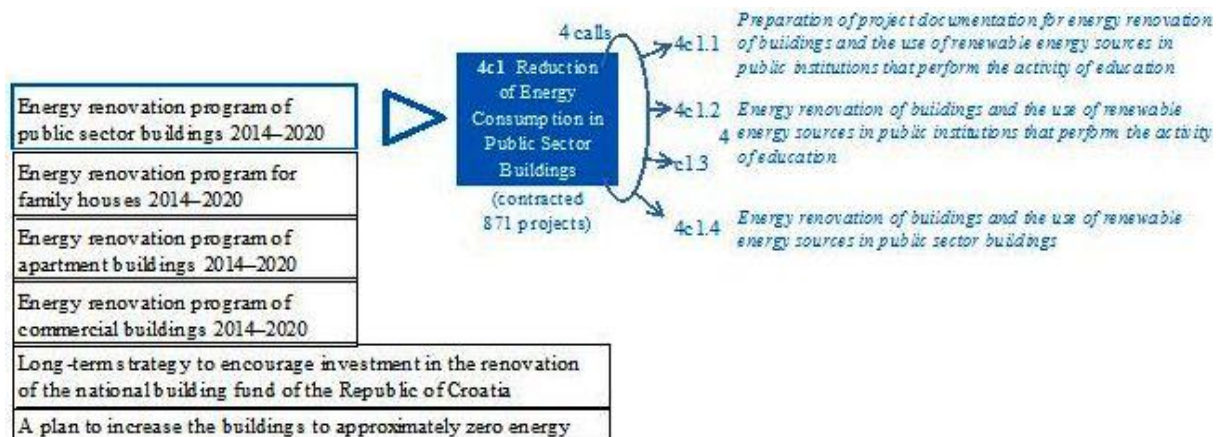
In Croatia, the Construction Act (2014) stipulates that each building, depending on its purpose, must be designed and constructed in such a way that during its duration it meets the basic requirements for the building and other requirements. One of the seven basic requirements for buildings is energy management and heat conservation, [9]. Regulations only require that buildings are maintained in such a way that their technical properties are preserved during their lifetime and that the requirements set by their design and the regulations are met in accordance with which they were built, [10]. According to the EPBD, in case of a significant renovation of an existing building, EU Member States must take measures to meet the established minimum energy efficiency requirements, if technically, functionally, and economically feasible, [8]. Therefore, the Technical Regulation on Rational Use of Energy and Thermal Protection in Buildings (2015) stipulates that before a significant renovation of a building (where more than 25% of the building envelope area is renovated) the design engineer should analyse the existing condition of the building and present measures for the improvement of the building's existing condition, together with investment assessment in terms of healthy indoor climate conditions, fire protection and earthquake risks, [11].

Until 2016, there was national (co) financing of energy renovation in Croatia [12], and since 2016 the renovation of public buildings has been financed from EU funds under the "Competitiveness and Cohesion" programme (approved by the European Commission at the end of 2014). This operational programme consists of 10 priority axes, and within Priority Axis 4 Promoting energy efficiency and renewable energy sources there is investment priority 4c - Supporting energy efficiency, smart energy management and the use of renewable energy sources in public infrastructure, including public and residential buildings sector. The Ministry of Physical Planning, Construction and State Property is a Level 1 Intermediate Body and the specific objectives within its authority are [3]:

- 4c1 Reduction of Energy Consumption in Public Sector Buildings
- 4c2 Reduction of energy consumption of residential buildings (multi apartment buildings and family houses).

The Fund for Environmental Protection and Energy Efficiency (EPEEF) is a central place for collecting and investing extra-budgetary funds in programmes and projects for environmental and nature protection, energy efficiency and the use of renewable energy sources in Croatia. In the system of management and control of the use of EU structural instruments in Croatia, the EPEEF has the role of Intermediate Body 2 for certain specific objectives in its field.

Fig. 1 shows the policy and programmes for energy efficiency improvement of buildings in Croatia in the period 2014-2020.



**Fig. 1.** Review of previous policies and measures for energy improvement of the building stock in Croatia with emphasis on energy renovation of public buildings (according to [12]).

Although the highest consumption in residential buildings (single-family homes and apartment buildings) is the allocation of budgetary funds under EU cohesion policy for the period 2014-2020 for energy efficiency investments, it shows that investments in public buildings were slightly more than twice as high as investments in residential buildings. The investments structure in buildings' energy renovation in Croatia, according to EPEEF, shows that by mid-2019 the largest investments were in public sector buildings, slightly less in family houses, and more than half less in apartment and commercial buildings together (in apartment buildings about six times more than investment in commercial buildings), [13].

In 2017, the Energy Renovation Programme of Public Sector Buildings was adopted in Croatia with the aim of raising the level of activities in energy renovation to 3% of the total stock of public sector buildings per year, reducing energy consumption for cooling / heating of renovated public sector buildings to 70%, or annual savings of about 50 GWh and fulfillment of energy saving goals of public sector buildings (buildings of the central state, local and regional government units' buildings (counties, cities, municipalities), ie buildings owned by the public sector, in which social activities are performed (education, science, culture, sports, health and social care), etc.), [14]. Croatia has chosen an alternative approach and an energy savings target, expressed in petajoules (PJ) has been set. The National Energy Management Information System (NEMIS), which contains information on actual energy and water consumption in public sector buildings (for more than 14,000 buildings), was used to assess the energy savings target. The calculated target for Croatia of the equivalent of savings in energy renovation of state buildings of 3% per year is 0.00489 PJ per year, [2].

In order to transform the existing building stock into an energy efficient and decarbonized one, a long-term strategy for the renovation of the national building stock until 2050 was adopted at the end of 2020. According to that document, 5% of buildings in Croatia have been energetically renovated so far, and about 0.7% of the buildings' floor space has been renovated annually. The planned goal is to gradually increase the renovation rate, from 1% of the floor space in 2021 to over 3% after 2030, [15]. In order to overcome the existing obstacles (primarily to increase the thermal protection of the building envelope), the Ministry of Culture, in coordination with the Ministry of Construction and Physical Planning, developed Recommendations for the application of energy efficiency measures on building heritage.

The Croatian government has also adopted a National Recovery and Resilience Plan for 2021-2026 (which should start implementation at the end of 2021) in which one of the six components is the Initiative: Renovation of Buildings. This component of the plan will encourage the complete renovation of buildings and should contribute to the renovation of buildings after two major earthquakes in Croatia last year. The renovation will include residential and non-residential buildings, as well as public buildings, while respecting the importance of the public interest for health and educational buildings, [16].

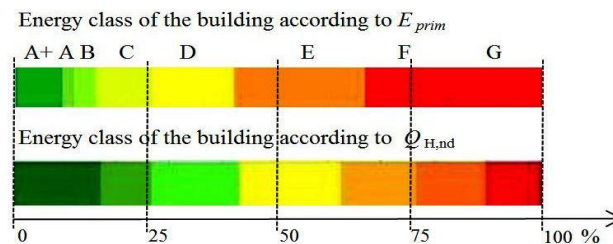
Anticipated renewmodels of building renovation are [12]:

- Individual energy renewal measures (for achieving gradual deep renewal),
- Integral energy renewal (combination of several energy renovation measures with mandatory inclusion of thermal protection of the building envelope),
- Deep renewal - includes energy efficiency measures on the envelope and technical systems and should result in a reduction of energy consumption for heating ( $Q_{H,nd}$ ) and primary energy ( $E_{prim}$ ) on an annual basis of at least 50% compared to consumption before renovation,
- Comprehensive renewal - in addition to energy renovation measures of the building, it also includes measures to increase safety in case of fire, to ensure a healthy indoor climate, to improve the mechanical resistance and stability of the building (reducing the risk of earthquakes).

## **EDUCATION BUILDINGS' RENEWAL PROCESS 2017–2021**

According to data from NEMIS, a total of slightly more than 13.8 million square meters of floor area of public sector buildings was recorded in Croatia (of which 43.9% was heated floor area). Education buildings are one of the categories of public sector buildings and have an area share of 40.7%. According to this share, the total energy consumption and CO<sub>2</sub> emissions of these buildings stand out. This category includes primary, regional, and secondary schools (with and without a gym or a workshop), as well as university buildings and kindergartens. 54.5% of them were built before 1971,

and in the period 1971–2006, 44.9% were built. These buildings are, in a larger number and area, owned more by local and regional government units, than by the central state administration, [14]. In continental Croatia, 28.6% of educational buildings are now in the three worst classes, and 17.6% are in the A and A + classes [15]. Fig. 2 shows the existing distribution of energy classes in educational buildings according to the share in the total area of these buildings throughout Croatia. An overview of the energy efficiency classes of buildings by primary energy in Fig. 2 shows a higher number of those with a poorer class compared to the energy classes determined by the energy required for heating. This is mostly because primary energy also includes cooling and lighting energy, which makes up a significant share of consumption in this type of buildings.



**Fig. 2.** Energy efficiency classes of buildings for education according to the share in the total area of that type of buildings, viewed according to two methods of calculation (data from [15])

The school buildings' renewal projects in Osijek-Baranja County, analysed in this article, are co-financed by the European Structural and Investment Funds (established to implement EU regional policy aimed at reducing regional disparities in income, wealth and opportunities) under Operational Program "Competitiveness and Cohesion" 2014–2020. Based on the Public Tender of the Ministry in charge, this county applied as a beneficiary to (along with some other counties, individual cities and municipalities, various ministries and public institutions for their buildings, such as individual schools, kindergartens, health centers, hospitals, homes for the elderly and infirm, cultural centers, fire stations, etc., depending on the specific purpose), [17]. The calls were:

- 2017 for Specific Objective 4c1: Reduction of energy consumption in public institutions performing the activity of education (at the end of the same year, 214 contracts were signed for projects throughout Croatia) and
- 2018 for Specific Objective 4c1: Reduction of energy consumption in public sector buildings (a total of 550 contracts were signed throughout Croatia).

It should be noted that Osijek-Baranja County had the largest number of projects of all counties (20 + City of Zagreb), and in addition, some other schools in the area of this county were energetically renovated. The City of Osijek, which is the center of the county, was the beneficiary of these two calls for co-financing for five energy renovation projects of school buildings in its area. (These projects are not analysed in this article due to the lack of necessary data for comparison.)

In addition to non-refundable EU funds and funding from the Ministry of Regional Development and European Union funds, Osijek-Baranja County participated in many of these projects in funding with significantly less than 20% of the value. Financial support was provided for energy renovation measures that will result in a reduction of heating / cooling energy per year (kWh) of at least 50% compared to consumption before the implementation of the measures. Therefore, obtaining financial incentives for these projects was based on an energy audit showing an improvement in the energy class. The implementation period of these contracted renovation projects is 24 months.

## THE ANALYSIS OF SCHOOLS' ENERGY RENEWAL IN OSIJEK-BARANJA COUNTY

48 schools' energy renewal projects in Osijek-Baranja County are analysed here (8 secondary and 40 primary and regional schools in cities and other places in this county) which data are publicly available on the website of Osijek-Baranja County for ([18]). Thus, a statistically significant number of samples was obtained (the least data of the same type is for 43 buildings, which is > 30).

Energy renovation projects were analysed with respect to the previously existing and improved energy class, project costs (known to all), achieved energy savings and reduction of greenhouse gas / CO<sub>2</sub> emissions, age of buildings and building area (all these data are not known for all renovated schools).

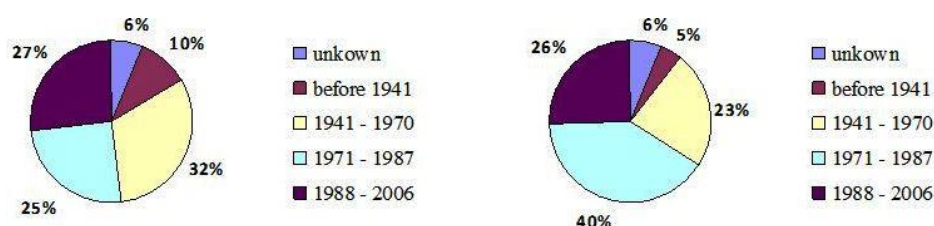


Data on the year of construction are known for 45 buildings and among them there are those from the end of the 19th and the beginning of the 21st century. There are different classifications of buildings according to the time of construction (e.g. according to Housing Statistics in EU (2010) there are 7 construction periods: before 1919, 1919–1945, 1946–1970, 1971–1980, 1981–1990, 1990–2000, after 2000, [19] or on built until 1970 and those after that as in [14]). For this analysis, buildings are divided into periods characterized by the application of building materials and thermal insulation regulations in Croatia. The characteristic periods are explained in Table 1. The heat transfer coefficients of the characteristic structures of the outer envelope of buildings decrease most noticeably in glazed structures, continuously throughout all periods of construction. On the exterior walls' constructions, after the deterioration that took place after World War II and until the 1970s, there has been constant, significant improvement, [15].

**Table 1.** Periods into which buildings are divided to consider energy renovation parameters

Construct. period	The buildings' characteristics
before 1940	- massive constructions prevail (brick or stone walls thickness = 38 cm and more), basements and attics under sloping roofs (buffer heating zones), twin sash windows
from 1941 to 1970	- light reinforced concrete structures (without insulation, thermal bridges), flat roofs, single layered glass windows with poor quality profiles (worst construction)
from 1971 to 1987	- similar to the previous period - reinforced concrete walls (thickness = 16–18 cm) or made of brick blocks (thickness = 19 cm), but the first regulations on thermal protection were introduced (minimum insulation of the envelope with 2–4 cm of heraclite, wood or EPS plates)
from 1988 to 2005	- construction according to Yugoslav Standard, which prescribes better thermal insulation of the building envelope (for external walls 4–8 cm of stone wool and polystyrene, i.e. styrofoam, and for a sloping roof 8–12 cm of thermal insulation)
after 2006	- harmonized with technical regulations on rational use of energy and thermal protection in buildings (since 2006 the Technical Regulation on thermal energy saving and thermal protection in buildings has been applied)

Fig. 3 shows the representation of school buildings according to the characteristic periods of construction. (For three school buildings for which there is no data on the time of construction, according to the external appearance, it can be assumed that they are probably from the period between 1941 and 1987).

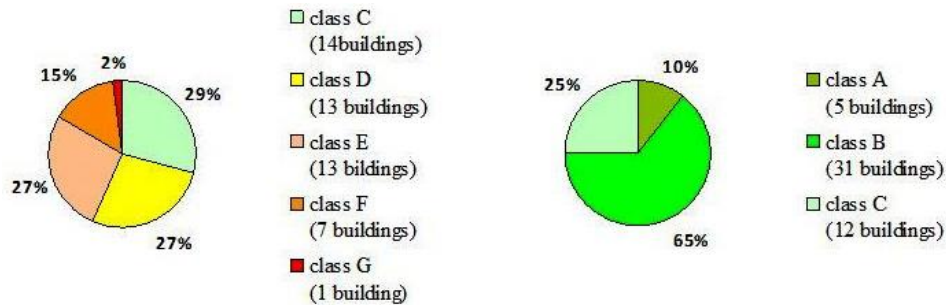


**Fig. 3.** Share of renovated schools according to the construction period - left according to the number of buildings, and right according to the areas (without the buildings for which the area is not known)

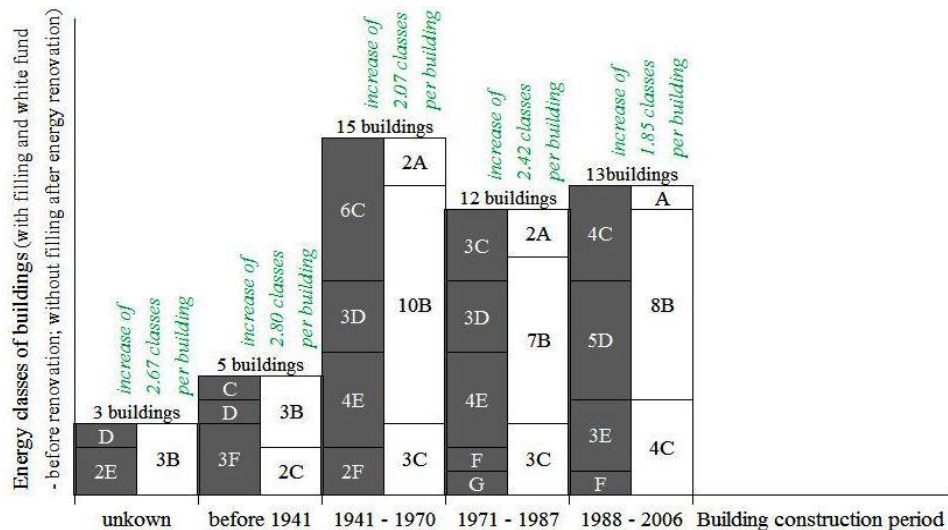
In these school buildings, the main measures envisaged by the energy renovation project were:

- 100% thermal insulation of the envelope (walls / facade, ceiling to the attic and / or roof - depending on the construction of the building);
- 96% replacement of exterior carpentry and hardware with new, more energy efficient (e.g. wooden or aluminum with PVC);
- 79% reconstruction / improvement of the heating system (installation of a high-efficiency gas condensing boiler, change of energy source - transition from heating oil to wood biomass, new heating stations, installation of thermostatic valves on heating bodies, etc.);
- 17% replacement of lighting with more energy efficient (e.g. LED).

Fig. 4 shows the share of energy efficiency classes that buildings had before and after renovation, and Fig. 5 shows this by periods of construction and what is the average increase in classes per building in each period. The cost of renovation (project value) for all these buildings was close to 144 million kunas, or € 19,221,064 (according to the current middle exchange rate). For 43 buildings, for which the area is known (from 199 to 12,795 m<sup>2</sup>), renovation costs per square meter were calculated and they are listed in Table 2, among other important parameters.



**Fig. 4.** Number of species (share) of energy efficiency classes before (left) and after renovation of buildings (right)



**Fig. 5.** Energy classes of school buildings before and after renovation

**Table 2.** Average data on renovated buildings and data by periods

Parameters	Average for all buildings	Construction periods				
		unknown	before 1941	1941–1970	1971–1987	1988–2006
Area (m <sup>2</sup> )	2,583	3,554	1,004	2,142	4,972	2,592
Costs per building	400,438	505,625	168,383	372,289	590,435	322,517
Costs per unit area (€ / m <sup>2</sup> )	161	205	168	167	158	145
Reduced CO <sub>2</sub> emissions (% / building)	66	69	61	68	74	58
Planned savings kwh per building	193,784	34,851	48,829	173,257	319,179	166,537

Table 2 shows, as expected, that the cost of renovation per square meter of building area decreases in buildings constructed later and that the least energy savings are planned for buildings from the earliest period.

According to the data from [14], the average costs of the total investment (for the envelope of buildings, thermotechnical systems and lighting) of energy renovation of educational buildings in

Continental Croatia built before 1970 were 1,295 kn / m<sup>2</sup> (173 € / m<sup>2</sup>), and for those built later (until 2005) 920 kn / m<sup>2</sup> (123 € / m<sup>2</sup>). The average energy renovation costs for the school buildings built before 1970, and analysed here, were 167 € / m<sup>2</sup> (less than the average for all educational buildings), and for those from the later construction period 144 € / m<sup>2</sup> (more than the average for all buildings for education). The conclusion can be drawn that the initial condition of school buildings from different periods is more uniform (at least in Osijek-Baranja County) than in all educational buildings in Continental Croatia. There is an interesting comparison with the energy renovation of family houses in the same county. The results of this renovation are presented in [7] on a sample of 100 family houses inspected and renovated in 2015–2016 (2% built before 1941, 13% from 1941–1970, 46% from 1971–1987, 32 % from 1988–2006 and 7% after 2006). This was in the last completed cycle of the Programme for energy renovation of family houses 2014–2020. At that time, the owners had their renovation co-financed with 40–80% (depending on the area) exclusively from national funds and there were no conditions for achieving minimum energy savings. The average investment in the energy renovation of the considered houses was € 10,414 and considering the average renovated net area of the house of approx. 120 m<sup>2</sup> it is 87 € / m<sup>2</sup>, [20].

Compared to school buildings, the initial energy classes of houses were worse in all periods of construction. (Before the renovation, 72% of these houses had one of the three worst energy classes and there was a ten times higher share of houses than school buildings with energy class G before the renovation.) This can be largely attributed to the poorer quality of construction and poorer maintenance of houses than public buildings. As with school buildings, the worst classes after the renovation of houses remained with those built before 1941. On average, 2.08 measures were taken to improve energy efficiency in houses (which is less renovation work than on school buildings). The most common measure was the replacement of the outer carpentry, followed by the thermal insulation of the outer envelope. This increased the energy class to 85% of the renovated houses, and the best energy class achieved was B, [7]. In the energy renovation of school buildings, the energy class of all buildings has been raised by a minimum of one and a maximum of four classes. The minimum energy savings for heating in renovated houses was 5% (where only the exterior carpentry was changed), and the largest was 63% (achieved by a combination of several renovation measures), which is significantly less than in the renovation of school buildings.

## **CONCLUSION**

A more detailed processing and analysis of the parameters of energy renovation of school buildings in one continental county gives a more reliable picture of the state of the stock of buildings of this type and allows better framework planning of similar projects. It turned out that we should strive for the most comprehensive renovation of buildings, because in this way better results are achieved in less time and money than with partial measures. This is in line with the National Recovery and Resilience Plan 2021–2026 in Croatia which anticipates the reconstruction of energy reconstructed buildings damaged in the earthquake. Possible savings, i.e. avoiding costs when linking various maintenance and renovation measures of buildings with other works on them are shown in [21].

Croatia is facing a longer period of implementation of various programmes and projects to achieve the planned goals of reducing energy consumption, and given the always limited resources (financial, human, time), measures should be well planned and focused on the area where they will give the greatest effects. The existing building stock in Croatia represents an individual sector with the greatest potential for energy savings, [14]. Most of the existing buildings were built decades ago, in accordance with the energy requirements that are obsolete today, and belong to energy class E, F or G [3]. But they still have a long service life ahead of them and their energy recovery brings more very desirable effects. In addition to financial savings and pollution reduction, there are other, very diverse direct and indirect benefits of reconstruction that need to be considered. (e.g. better feeling of comfort and healthier conditions for space users (less moisture and its negative consequences), employment of the construction sector through the implementation of energy renovation projects, increasing the value of buildings, etc.). In case of public buildings, the energy savings achieved by investing in the energy renovation of residential buildings are monitored (not the case in case of residential buildings at all), but no other indicators measure the other benefits achieved with these investments [1]. This would be

necessary for a more complete analysis of the efficiency of energy recovery and greater motivation for its implementation.

For the transformation of public, both school and other buildings, into energy-efficient and decarbonized buildings, different obstacles have been noticed: financial (long payback period), legal (complex and lengthy procedure for obtaining financial support, lack of legal obligation to improve the basic properties of the building in relation to those according to which built, protection of buildings that are cultural property, and which are among those for education) and social (insufficient availability of skilled labour and the trend of emigration and depopulation), [15].

After improving the energy performance of buildings, it is important to further proper and timely maintenance of these buildings and their equipment (heating and cooling systems, windows, etc.). Technical conditions for lower energy consumption (lower losses) are achieved that way, but to have these possibilities achieved, it is necessary to motivate the users themselves, especially if they do not pay the bills for the consumed energy.

## REFERENCES

- [1] European Court of Auditors, Energy efficiency in buildings: greater focus on cost-effectiveness still needed, Special Report 11/2020.
- [2] Ministry of Environmental Protection and Energy (Croatia), Annual report, Zagreb, 2018.
- [3] Internet source: Ministry of Physical Planning, Construction and State assets website: <https://mpgi.gov.hr/o-ministarstvu-15/djelokrug/energetska-ucinkovitost-u-zgradarstvu/8303>
- [4] Bazan-Krzywoszanska, A., Mrówczyńska, M., Skiba, M., Łączak, A.: Economic conditions for the development of energy efficient civil engineering using RES in the policy of cohesion of the European Union (2014–2020). Case study: The town of Zielona Góra, Energy and Buildings, Vol.118, pp. 170-180, 2016.
- [5] Hsu, D.: How much information disclosure of building energy performance is necessary? Energy Policy, Vol.64, pp. 263-272, 2014.
- [6] Krstić, H., Teni, M.: Algorithm for constructional characteristics data cleansing of large-scale public buildings database, High Performance and Optimum Design of Structures and Materials III, pp. 213-224, WIT Press, Southampton, 2018.
- [7] Hećimović, D., Vidaković, D., Pavelić, K.: Energy reconstruction family houses in Osijek-Baranya county, Proceedings of 8th International Natural Gas, Heat and Water Conference, pp. 156-165, Osijek, 2017.
- [8] Directive on energy efficiency, 2012/27/EU
- [9] Zakon o gradnji, Narodne novine, No.153, 2013.
- [10] Tehnički propisi za građevinske konstrukcije, Narodne novine, No.17, 2017.
- [11] Tehnički propis o racionalnoj uporabi energije i toplinskoj zaštiti u zgradama, Narodne novine, No.128/2015, 70/2018, 73/2018, 86/18, 102/2020.
- [12] Žamboki, D., Križ Šelendić, I.: Energetska i sveobuhvatana obnova zgrada, Prezentacija izlaganja na 15. Danima Hrvatske komore inženjera građevinarstva, Opatija, 2021, Available at [https://www.hkig.hr/docs/Opatija\\_2021/prezentacije/01-web\\_prezentacije/](https://www.hkig.hr/docs/Opatija_2021/prezentacije/01-web_prezentacije/)
- [13] Šandrk- Nukić, I.: Sustainable management of energy consumption in public buildings as a determinant of sustainable economy, Ekonomika misao i praksa, Vol.29, pp. 247-268, 2020.
- [14] Odluka o donošenju Programa energetske obnove zgrada javnog sektora za razdoblje 2016. – 2020., Narodne novine, No.22, 2017.
- [15] Ministry of Physical Planning, Construction and State Assets, Dugoročna strategija obnove nacionalnog fonda zgrada do 2050. godine, Zagreb, 2020.
- [16] Internet source: Government of the Republic of Croatia, Central State Portal website: <https://planoporavka.gov.hr/o-planu/inicijativa-obnova-zgrada/111>.
- [17] Internet source: Europski strukturni i investicijski fondovi, Natječaji - Energetska obnova i korištenje obnovljivih izvora energije u zgradama javnog sektora website: <https://strukturnifondovi.hr/natjecaji/energetska-obnova-koristenje-obnovljivih-izvora-energije-zgradama-javnog-sektora/>

- [18] Internet source: Osječko-baranjska županija, Upravni odjel za investicije i razvojne projekte, Energetska obnova zgrada škola website: <http://www.obz.hr/index.php/upravni-odjel-za-investicije-razvojne-projekte-i-fondove-europske-unije>.
- [19] Housing Statistics in European Union, T.H.M.o.t.I.a.K. Relations, 2010.
- [20] Hećimović, D., Vidaković, D.: Analiza isplativosti energetske obnove obiteljskih kuća u Osječko-baranjskoj županiji, Proceedings of 27th International Scientific and Professional Conference "Organization and Maintenance Technology", pp. 97-104, Osijek, 2018.
- [21] Vidaković, D., Hadzima-Nyarko, M., Ademović, N., Lozančić, S.: Maintenance of building elements to fulfill the basic requirements buildings, Proceedings of 30th International Scientific and Professional Conference "Organization and Maintenance Technology", Osijek, 2021., Article in press.

## EMOTIONAL INTELLIGENCE AND LEADERSHIP IN CONSTRUCTION MANAGEMENT

Nazi Ghamkhar<sup>1</sup>, Ali Reza Afshari<sup>2</sup>, Sanja Stanisavljev<sup>3</sup>

<sup>1</sup>Department of Construction Management, Mashhad Branch, Islamic Azad University,  
Mashhad, Iran.

<sup>2</sup>Department of Industrial Engineering, Shirvan Branch, Islamic Azad University, Shirvan,  
Iran.

<sup>3</sup>University of Novi Sad, Technical Faculty “Mihajlo Pupin”, Zrenjanin, Serbia  
e-mail: [ghamkhar@mshdiau.ac.ir](mailto:ghamkhar@mshdiau.ac.ir)

**Abstract:** The purpose of the research was to explore the significant of emotional intelligence and its impact on leader behaviour through intrapersonal and interpersonal skills, so construction managers would embrace the emotional mind as well as the cognitive mind to minimize conflict, increase project success, and establish healthier relationships. The data generated from the research study provides a unique collection of data that resulted from the integration of the EI intervention into the Construction Management Concepts that did not previously exist. The findings suggest that teaching construction managers to use both the emotional and cognitive learning attributes are important for authentic learning to happen.

**Key words:** Project Management, Leadership Skills, Emotional intelligence, Construction Management.

### INTRODUCTION

The increasingly complex environment of construction projects has led to an urgent need for project managers to improve their ability to lead teams and adapt to complexity and uncertainty [1]. The personal attribute ability of the project manager has more influence on the employees than the technical ability [2]. Specifically, emotional intelligence (EI) reflects an ability to guide thinking and action and is a key factor in daily managerial success [3]. Stephens and Carmeli [4] believed that individuals with a high level of EI expand their knowledge and skills base to improve their ability to communicate and cooperate effectively. Managers with high EI stimulate good attitudes and work behaviour by meeting the emotional needs of employees.

Over the past two decades the “human side” of project management has increasingly been identified as a critical component of the project manager’s role associated with project management success [5]. Researchers have found that challenges in construction projects are largely associated with human skill and competencies, rather than technical issues. Human skill and competency is a critical part of managing large-scale projects, influencing on successful delivery of projects. Researchers such as Mazur et al. [6], Müller and Turner [7] and Rezvani et al. [3] have revealed that behavioural skills and competencies, more specifically emotional intelligence (EI), defined by Mayer et al. [8] as the ability to be aware of, to manage, and to understand emotions in self and others, can affect the outcomes of major projects. Rezvani et al. [3] and Mazur et al. [6], for instance, found that managers with high levels of EI are more motivated to become involved in effective communications and are more creative regarding complex tasks, resulting in increased chances of project success in major projects.

Past research [3, 6, 9] has shown the importance of EI to the achievement of successful outcomes, the project management literature is replete with unsubstantiated generalizations, with much of the existing evidence bearing on the role of EI for project managers. Therefore, our first goal is to extend research in the field of EI [3, 10] to research in construction projects. Our focus in this research lies in construction project environments due to their major influence on our society by supporting its foundation. In addition, prior research has indicated the relevance of EI to construction projects and project performance [3, 6, 11]. The overarching research question for this study is how is a transformative approach to emotional intelligence, related to important aspects of successful business practices? The specific research question guiding this study are as follows:

- What is the relationship between emotional intelligence training and leadership skills and teamwork of construction project managers?

## MATERIAL AND METHODS

### EI and Leadership in construction

Leaders and their ability to provide effective leadership are vital and critical to the sustainability of a global society. Northouse [12] expressed leadership as a process whereby an individual influences a group of individuals to achieve a common goal with the ability to understand emotions and apply this understanding to life's tasks. He suggests that in order for effective leadership to manifest, leaders will need to exhibit a more personal sensitive approach when interacting with team members. The need for leadership in the construction industry is mainly because the success or failure of construction projects is highly dependent on who is leading and coordinating them. However, 80% of project failures are due to poor leadership, including inadequate leadership skills, lack of teamwork, inefficiency in problem-solving, and weaknesses in communication [13]. Most of the leadership challenges, particularly in the construction industry, relate to its workforce, including shortage of good-quality workers, an aging workforce, teamwork, communication, training, and education [14]. In addition, some failures in the construction industry have become the subject of continuous criticism especially its fragmentation and poor record on quality, waste, financial claims, safety, and efficiency [15]. For all of these failures, one of the causes is ineffective leadership. Undoubtedly, the construction industry is large and technically complex and involves a combination of specific skills. The leadership will be shared through teamwork, and the position of the leader in teams will rotate. Thus, the construction teams are not only large but also involve various disciplines and this makes leadership significant in the construction industry.

The need for leadership in the construction industry is mainly because the success or failure of construction projects is highly dependent on who is leading and coordinating them [16]. Undoubtedly, the construction industry is large and technically complex and involves a combination of specific skills. The leadership will be shared through teamwork, and the position of the leader in teams will rotate. Thus, the construction teams are not only large but also involve various disciplines and this makes leadership significant in the construction industry [13]. Most of the authors highlighted communication and teamwork as the most important skill for project managers in sustainable construction projects. Construction projects can be more complicated than traditional projects thereby increasing the need for project team communication and teamwork. Construction project managers should lead a team process to establish clear guidelines for communication and ground rules for teamwork, such as training to enhance these skills [17]. The relationship between EI and leadership in project management has been investigated at different levels [1]. Butler and Chinowsky [18] found that EI behaviours such as interpersonal skills and empathy are significantly related to transformational leadership in construction executives. Similarly, Sunindijo et al. [19] examined the relationships between EI and thirteen leadership behaviours in construction projects and found that project managers with higher EI prefer open communication and proactive leadership styles.

Construction managers' leadership style can influence a project's outcome [20]. Similarly, Nam and Tatum [21] have stated that effective leadership is fundamental for innovation in construction. Construction project managers who are deemed emotionally intelligent should be able to positively utilize charismatic leadership skills to regulate their own and others' emotions, and use emotional information for decision-making to achieve creative and positive outcomes. In particular, Butler and Chinowsky [22] have found a significant relationship between EI and transformational leadership behaviour among construction executives. In a similar vein, Sunindijo et al. [19] demonstrated that EI influenced the style of leadership adopted by project managers and engineers in construction projects. It revealed that project managers and engineers with higher levels of EI tended to utilize open communication and proactive leadership styles. Sunindijo et al. [19] also found it that EI generates delegation, open communication, and proactive behaviour, which provide positive outcomes within a project environment.

Construction project managers should also be engaged in team building skills for the success of their project. The results of a survey from Singapore revealed that project managers who are equipped with good team building skills could improve project team cohesiveness as well as enhancing the overall project team performance [23]. Interpersonal skill is the ease and comfort of communication between individuals and their colleagues, superiors, subordinates, clients, and other stakeholders [24].

Interpersonal skill includes the ability to motivate others, conflict management, effective communication, and team building. In order to motivate others, construction management personnel have to determine what drives people to exhibit certain behaviour, what directs or channels people's behaviour, and how the behaviour is sustained [25]. Construction management personnel should be flexible, depending on the situation, in using different styles to manage conflicts. There are five-conflict resolution styles based on the levels of assertiveness and cooperativeness: avoiding, dominating, accommodating, compromising, and collaborating. Furthermore, in order to manage social interactions, construction management personnel should also be effective communicators to ensure that all stakeholders are 'on the same page' throughout construction life cycle. They have to listen effectively; have strong verbal, graphical, and written communication skills; deliver good and bad news effectively; have strong presentation skills; and be able to liaise among stakeholders [26]. Lastly, construction management personnel should be able to build teamwork and cooperation by showing genuine intention to work cooperatively with others and use different approaches to get the best out of the team [27]. A construction project team is temporary where people, in many cases from different organisations, come together for only one project with no guarantee of ever doing so again. This type of team has distinct characteristics and offers more challenges than the teams in other industries. Teambuilding and teamwork, therefore, is crucial for managing the knowledge and skills of the human capital and making them as a competitive advantage instead of an inhibitor of delivering successful construction projects. It is a fact that individuals have to be effective self-managers before overcoming barriers to interpersonal effectiveness because self-management gives individuals credibility in their interactions with others. This credibility along with the capacity to manage emotional outbursts are keys to effective communication, which is a foundation to resolve conflicts and build teamwork [28]. Furthermore, self-management is a source of achievement drive and initiative, which are crucial for motivating oneself and others. Sunindijo et al. [19] found that social awareness is related to sharing and open communication. This sensitivity to others is critical for superior job performance whenever the focus is on interactions with people. Furthermore, socially aware individuals are emphatic. They have an ability to put themselves in someone else's shoes, sense their emotions, and understand their perspective, thus enabling them to interact effectively with different types of personalities. This explains why social awareness is a prerequisite of interpersonal skill. Among the three dimensions, relationship management has the highest opportunity to influence the application of interpersonal skill.

Communication skills involve an ability to exchange information with a person or group. Otherwise, communication is especially important for project managers in construction projects. For instance, in the initial stage, a project manager needs to communicate with stakeholders about achieving its goals. This is because a project manager is responsible for holding the initial meetings that benefit the communication between the project teams. Hence, the communication skills of a project manager may accommodate the different perceptions among project team and the stakeholders to ensure a successful outcome for the construction project [17]. Communication recognised as one of the key skills for the project manager [29]. Communication between team members and the entire network of stakeholders is vital to support the understanding of all involved in the project and their goals [30]. Considered as one of the reasons for the success or failure of the project, effective communication between the project manager, staff, and stakeholders is essential. Sharing a language with terms in common use among staff and stakeholders and establishing communication standards are means to achieve effective communication. Project manager must understand how those involved in the project communicate and to keep the informal channels of communication open [9].

## **Research Method**

The research documents the impact of integrating an emotional intelligence curriculum and its influence on intrapersonal and interpersonal skills to improve leadership and team performance effectiveness in construction managers. Both the experimental group and the control group completed the EI pre-assessment. A two-week intervention was scheduled and delivered to the experimental group while the control group received the standard curriculum. The variables in the study included four dimensions with a combined 13 emotional intelligence skills from the Emotional Skills Assessment Process. However, the study only focused on Intrapersonal Dimension, Interpersonal



Dimension and Leadership Dimension as the dependent variables. The variables from the Team Member Effectiveness instruments were team satisfaction, team cohesiveness, team effectiveness as dependent variables. Emotional intelligence served as the independent for the study. The purpose of the research was to explore the impact of emotional intelligence on leader behaviour and team effectiveness. The purpose of the EI treatment intervention was to assist managers with developing strategies to discover the value and importance of using emotions intelligently to achieve success in all areas of construction project.

The research participants were composed of 53% male and 41% female managers (6% missing data). The mean age of the participants was 33. Participants divided into an experimental group and a control group. The experimental group received the EI intervention while the control group received the traditional project management curriculum. The data collection based on archival data collected from an assurance of learning pilot program in fall 2019. The focus of the pilot was to explore ways to enhance managers' skills by integrating an emotional intelligence intervention into the Project Management Concepts course. The researchers created the pilot design and concepts of the pilot program. An experimental design implemented to collect the data and test if an in-course intervention would improve individual manager skills. The researcher was an active participant in the program by administering the pre and post assessments.

**Intrapersonal skill:** This section seeks to explore Intrapersonal Skill in two emotional skill areas. The two areas in this section are self-esteem and stress management. Self-Esteem and Stress Management skills are essential to the mental and physical well-being of a 68 individual is self-worth and value [31]. The reliability of the self-esteem questions for the pre-assessment equalled (Cronbach's Alpha .83; N = 25) and the post assessment reliability was equivalent to (Cronbach's Alpha .83; N = 25). The pre-assessment reliability for stress-management was (Cronbach's Alpha .88; N = 25 and the post-assessment reliability for stress-management equalled (Cronbach's Alpha .93; N = 25).

**Interpersonal skills:** This section seeks to explore interpersonal communication skills under various difficult stressful situations. The three components in this section are assertive, aggression, and deference. Each contains eighteen items totalling 54 aggregate. Effective communication is vital in developing healthy relationships in any situation [31]. The reliability of the assertive questions for the pre-assessment equalled (Cronbach's Alpha .68, N = 18) and the post-assessment reliability was equivalent to (Cronbach's Alpha .82, N = 18).

**Personal leadership skills:** The four areas in this section are comfort, empathy, decision-making, and leadership. Each contains 12 components, creating 48 items for the section. Personal Leadership inspires effective leadership through the creation of healthy relationships with others utilizing characteristics such as integrity, trust, dependability, respect, and honesty [31]. Developing an emotional learning and skills process further enhances personal leadership, genuine respect, and care for others. The reliability of the comfort questions for the pre-assessment equalled (Cronbach's Alpha .76, N = 12) and the post-assessment reliability was equivalent to (Cronbach's Alpha .80, N = 12).

The personal leadership section has four emotional skills that assessed. The skills are comfort, empathy, decision-making, and leadership behaviour. According to Nelson and Low [31], a positive effective leader is socially aware of the team dynamics regarding the emotional needs and goals of the team members. Leaders show understanding and respect for the members. Rapport established through every positive interactions with such gestures as good eye contact, active listening, personal information exchange, and pleasant greeting to make the person feel comfortable during the interaction. Comfort enhances a person's confident spontaneity, enthusiasm, and open-mindedness with people. Establishing a good relationship with others requires work and active listening. Communicating empathy is accurately understand and respond based on the information received, feeling expressed, and needs exhibited by others. Using assertive communication and active listening while creating and expressing empathy, allows open communication to flow and establishes the foundation for healthier relationships. Straight talk can facilitate positive comfortable exchanges while creating healthy relationships. Healthy relationships also require effective problem solving and conflict-resolution strategies to resolve issues. Decision-making is systematic process that has an emotional component that influences the reasoning capacity of effective decision-making. The essence of effective decision-making is to create a positive influence and inspire the ability of the leaders to persuade and direct others in a positive manner [31].

**Self-management:** This section seeks to explore Self-Management in four emotional skills areas. The four areas in this section are Drive Strength, Commitment Ethic, Time Management, and Positive Change. The Drive Strength section contains twenty-five items and 73 the other three sections are comprised of twelve items totalling 61. The reliability of the drive strength questions for the pre-assessment equalled (Cronbach's Alpha .84, N = 25) and the post assessment reliability was equivalent to (Cronbach's Alpha .85, N =25). Self-Management skill is the nucleus for goal setting and high achievement through motivation, managing time, and a commitment to change and personal growth. Self-management is critical to achieving academic, career, and life success. It is imperative to enhance and accept responsibility for one's own learning in order to facilitate success. Moreover, the cognitive domain of the mind makes a conscious decision to be the best person that you created to be. On the other hand, the emotional domain of the mind is the battery that ignites the energy to achieve the goal and create a sense of excitement for executing the desired outcome. The Drive Strength skill is the catalyst to spark the energy needed from the emotional system to develop clear concise and well thought-out goals. Personal excellence is the ability "to motivate yourself, focus energy, and achieve goals". Perseverance or Commitment Ethic is staying the course and by developing extensive follow through skills to complete the required results. The internal emotional system views this as pride and externally it recognized as dependability. With demanding schedules, doing more with less, and rapid growth of the information age, "normal" levels of productivity are skewed and life is demanding more output, time, and flexibility. Time management and personal change are essential in developing "personal wellbeing and physical health".

Data reviewed and measured for consistency with the purpose of the study to identify a participant's total emotional intelligence score change. Data analysis was analysed according to the context of the research questions and the prescribed hypotheses. This research incorporated directional hypothesis as a process to predict a particular outcome of the study. The study designed to compare the level of emotional intelligence between the experimental group with the control group in the pre-and post-intervention phases.

## RESULTS AND DISCUSSION

The purpose of the quantitative experimental study was to investigate the influence of the EI intervention to improve construction manager's intrapersonal and interpersonal skills to impact leader behaviour. The goal of the research was to increase construction managers' post EI scores in specific skill areas of intrapersonal skills and interpersonal skills to their ability to lead and work effectively in a team environment. The statistical analyses based on 119 construction managers enrolled in four sections of the project management concepts course to measure the impact of the EI intervention on three of the five dimensions prescribed in the EI Post-test. Table 1 shows the mean EI score of construction managers in the experimental group who completed the Intrapersonal Dimension, the Interpersonal Dimension, and the Leadership Dimension of the EI Post-test. The results revealed that total EI scores average 327.12 with a standard deviation 37.03. Interpersonal Dimension average scores of 84.92 with the standard deviation of 12.6 were the highest of the three dimensions. The Leadership Dimension average score of 81.69 with the standard deviation of 9.4 indicating the mid-range of the three dimensions. Construction managers scored on average of 78.86 with a standard 85 deviation of 14 for the Intrapersonal Dimension indicating the lowest of the three dimensions listed.

**Table 1.** Descriptive Statistics EI Skills Post-test (Experimental Group)

Skills	Means	Standard Deviation
Total Leadership	76.05	11.4
Total Intrapersonal	76.23	12.6
Total Interpersonal	79.55	12.0
Total EI Score	309.30	39.03
Team Cohesiveness	11.99	2.15
Individual Satisfaction	12.08	2.96
Total Team Satisfaction	47.41	8.45

Hypothesis 1 suggested that the mean EI scores would increase from the pre-test to post-test for the experimental group but not for the control group. As shown in Table 2, results of a dependent samples t-test revealed that the control group's Total EI scores did not significantly increase from pre-test (M = 317.06, SD = 28.66) to post-test (M = 317.28, SD = 27.53),  $t(17) = -.04$ ,  $p = .97$ . In contrast, the experimental group's scores increased significantly from pre-test (M = 310.03, SD = 39.436) to post-test (M = 331.81, SD = 38.15),  $t(73) = -6.33$ ,  $p = .000$ . Thus, Hypothesis 1 supported.

**Table 2. Control Group and Experimental Group Total EI Scores Results**

Dependent Variables	Pre-test EI		Post-test EI		t	df
	M	SD	M	SD		
Control Group	317.06	28.661	317.28	27.53	-0.037	17
Experimental Group	310.03	39.436	331.81	38.158	-6.333	73

Hypothesis 2 suggested that the mean Intrapersonal EI scores would change significantly from pre-test to post-test for the experimental group but not for the control group. As shown in Table 3, results of a dependent samples t-test indicated that the control group's Intrapersonal EI scores slightly decreased from the pre-test (M = 79.56, SD = 9.79) to post-test (M = 78.50, SD = 9.62),  $t(17) = .72$ ,  $p = .477$ , but this decrease was not statistically significant. In contrast, the experimental group's scores increased significantly from the pre-test (M = 76.09, SD = 12.80) to post-test (M = 79.82, SD = 14.46),  $t(73) = -2.42$ ,  $p = .009$ . In addition to examining this hypothesis for the overall intrapersonal dimension, the researchers also tested whether both Self-Esteem and Self-Management competency scores for the intrapersonal dimension increased from pre-test to post-test for both the control and experimental groups. As shown in Table 3, results of dependent samples t-test revealed that the control group's Self-Esteem scores essentially remained the same from the pre-test (M = 41.72, SD = 4.65) to the post-test (M = 41.22, SD = 3.99),  $t(17) = .532$ ,  $p = .602$ .

**Table 3. Intrapersonal Dimension Results**

Dependent Variables	Control Group						Experimental Group					
	Pre-test EI		Post-test EI		t-Test		Pre-test EI		Post-test EI		t-Test	
	M	SD	M	SD	t	df	M	SD	M	SD	t	df
Intrapersonal	79.6	9.8	78.5	9.62	0.72	17	76.1	12.8	79.8	14.5	-2.42	.73
Self-Esteem	41.7	4.7	41.2	4.0	.532	17	39.92	6.0	42.6	5.4	-4.47	.73
Stress Manag.	37.8	7.0	37.3	6.4	.519	17	36.2	8.6	37.2	11.1	-8.65	.73

In contrast, the experimental group's mean scores increased significantly from pre-test (M = 39.92, SD = 6.00) to the post-test (M = 42.62, SD = 5.38),  $t(73) = -4.47^{**}$ ,  $p = .000$ . A dependent sample t-test results also indicated the control group's Stress Management scores showed no significant change from the pre-test (M = 37.83, SD = 7.04) to the post-test (M = 37.28, SD = 6.46),  $t(17) = .519$ ,  $p = .610$ . There was a slight increase in the experimental group's mean scores from pre-test (M = 36.18, SD = 8.64) to the post-test (M = 37.20, SD = 11.08),  $t(73) = -.865$ ,  $p = .195$ , but this increase was not statistically significant. Thus, Hypothesis 2 supported. Hypothesis 3 suggested that the mean Interpersonal EI scores would change significantly from pre-test to post-test for the experimental group but not for the control group. As shown in Table 4, results of a dependent samples t-test indicated that the control group's Interpersonal EI score increased from the pre-test (M = 80.67, SD = 11.34) to post-test (M = 80.83, SD = 12.68),  $t(17) = .071$ ,  $p = .944$ , was not statistically significant. In contrast, the experimental group's mean scores increased significantly from the pre-test (M = 79.72, SD = 12.31) to post-test (M = 86.61, SD = 11.27),  $t(73) = -6.19$ ,  $p = .000$ .

**Table 4. Interpersonal Dimension Results**

Dependent Variables	Control Group						Experimental Group					
	Pre-test EI		Post-test EI		t-Test		Pre-test EI		Post-test EI		t-Test	
	M	SD	M	SD	t	df	M	SD	M	SD	t	df
Intrapersonal	80.7	11.3	80.8	12.7	-.071	17	79.7	12.3	86.6	11.8	-6.2	73
Self-Esteem	25	4.2	25.3	4.4	-.271	17	26.6	4.3	28.4	5.8	-2.6	73
Stress Manag.	29.8	6.0	28.1	7.5	1.4	17	29.3	6.2	30.8	5.4	-2.9	73

In addition to examining hypothesis 2 for the overall interpersonal dimension, the researcher also tested whether the three competencies scores for the interpersonal dimension (Assertive Communication, Aggression (Anger Control and Management) and Deference (Fear and Control and Management) increased from pre-test to post-test for both groups. As shown in Table 4, results of a dependent samples t-test revealed that the control group's Assertive Communication scores essentially remained the same from the pre-test ( $M = 25.00$ ,  $SD = 4.15$ ) to the post-test ( $M = 25.28$ ,  $SD = 4.37$ ),  $t(17) = -.271$ ,  $p = .790$ . In contrast, the experimental group's mean scores increased significantly from pre-test ( $M = 26.62$ ,  $SD = 4.34$ ) to the post-test ( $M = 28.36$ ,  $SD = 5.77$ ),  $t(73) = -2.64^{**}$ ,  $p = .005$ . The results for Aggression (Anger Control and Management) indicated that the control group showed a non-significant decrease in change for pre-test ( $M = 29.78$ ,  $SD = 6.01$ ) to the post-test ( $M = 28.11$ ,  $SD = 7.53$ ),  $t(17) = 1.39$ ,  $p = .182$ . The experimental group's mean scores showed a statistically significant increase from the pre-test ( $M = 29.34$ ,  $SD = 6.18$ ) to the post-test ( $M = 30.84$ ,  $SD = 5.42$ ),  $t(73) = 2.90^{**}$ ,  $p = .003$ . The results also indicated the control group's Deference (Fear Control and Management) mean scores showed a non-significant increase from the pre-test ( $M = 25.89$ ,  $SD = 6.07$ ) to the post-test ( $M = 27.44$ ,  $SD = 4.90$ ),  $t(17) = -1.25$ ,  $p = .226$ . In contrast, there was a significant increase in the experimental group's mean scores from pre-test ( $M = 23.76$ ,  $SD = 6.99$ ) to the post-test ( $M = 27.41$ ,  $SD = 5.569$ ),  $t(73) = -5.86^{**}$ ,  $p = .000$ . Thus, Hypothesis 3 supported. Hypothesis 4 suggested that there would be a positive relationship between team cohesiveness (as measured by the CATME) and overall ESAP Skill measures. As shown in Table 5, the overall ESAP total score was significantly correlated with team cohesiveness ( $r = .26$ ,  $p < .05$ ). These results support for Hypothesis 4. In addition, examining the bi-variant relationships between the ESAP skill measure scores and team cohesiveness ratings, the researcher also investigated the relationship between team cohesiveness and interpersonal and intrapersonal skills totals score measures simultaneously using regression analysis.

**Table 5. Descriptive Statistics and Correlations among Study Variables**

Predictors	M	SD	N	1	2	3	4	5	6	7	8
Post Interpersonal Communication	78.86	14.14	98	--							
Post Intrapersonal	84.92	12.61	98	0.63	--						
Post Leader	79.12	13.14	98	0.41	0.38	--					
Post Emotional Intelligence	327.00	37.03	98	0.80	0.84	0.71	--				
Satisfaction Team Cohesiveness	11.99	2.15	90	0.21	0.27	0.18	0.26	---			
Team Satisfaction	12.80	2.96	90	0.19	0.12	0.05	0.12	0.69	--		
Team Effectiveness	11.8	2.11	90	0.26	0.24	0.15	0.24	0.85	0.90	--	
Emotional Intelligence Intervention	0.78	0.41	119	0.27	0.10	0.20	0.21	0.02	0.19	0.16	--

As shown in Table 6, the Post Total EI Interpersonal skill measures ( $b = .07$ ,  $p = .62$ ) and the Post Total EI Intrapersonal skill measures ( $b = .22$ ,  $p = .12$ ) combined did not account for a significant amount of variance in the team cohesiveness ratings,  $R^2 = .07$ ,  $F(3, 72) = 1.98$ ,  $p = .97$ . Table 6 also indicates Post Total EI and Team Cohesiveness is significant ( $b = .26$ ,  $p = .02$ ) with  $R^2 = .05$ ,  $F(2, 73) = 2.12$ .

**Table 6. Multiple Regression Results for Team Satisfaction and Team Cohesiveness Predictor Model**

Predictor	Team Satisfaction Ratings (TSR) Team Cohesiveness Rating (TCR)	
	b	t
EI Intervention (TSR)	0.18	1.60
Post Interpersonal Communication (TSR)	0.13	0.89
Post Intrapersonal Total (TSR)	0.01	0.09
Post Total EI (TSR)	0.07	0.66
EI Intervention (TCR)	0.00	0.04
Post Interpersonal Communication Total (TCR)	0.07	0.40
Post Intrapersonal Total (TCR)	0.22	1.54
Post Total EI (TCR)	0.26	2.27
EI Intervention (TSR)	0.22	1.95
Post Leadership Total (TSR)	0.01	0.15
EI Intervention (TCR)	0.03	0.29
Post Leadership Total (TCR)	0.18	1.56
Post Leadership Total (TE)	0.12	1.11

## Research findings

The research designed to investigate the influence of Emotional Intelligence Management Concepts Curriculum to improve construction manager's intrapersonal and interpersonal skills to impact leader behaviour and team performance effectiveness. The purpose of the research was to explore the significant of emotional intelligence and its impact on leader behaviour and team effectiveness through intrapersonal and interpersonal skills, so construction managers would embrace the emotional mind as well as the cognitive mind to minimize conflict, increase project success, and establish healthier relationships. The study utilized the quantitative research method with an emphasis on quasi-experimental non-equivalent groups to collect and analyse data to examine the research questions for this study.

Hypothesis 2 supported that the mean Intrapersonal EI scores would change significantly from pre-test to post-test for the experimental group but not for the control group. Participants in the experimental group benefited from the EI intervention. The participants' overall intrapersonal skills score increased significantly. Sunindijo and Hadikusumo [28] explained the importance of EI skills and self-awareness to improve self-development. Participants became more self-aware of their emotions and self-worth as a person because of the intervention. Intrapersonal skills consist of two competencies self-esteem and stress management. The experimental group appeared more self-confident in their ability to connect with others and accomplish their goals. Individuals that are more confident may be able to attract persons of like qualities [32]. The result suggested participants had a good self-image and motivated themselves through self-talk and stay focus on their positive attributes. Stress management is the other competency skill housed under the intrapersonal dimension [33]. Participants controlled their emotions and developed coping strategies to handle conflicts and stressful encounters.

Hypothesis 3 supported that the mean Interpersonal EI scores would change significantly from pre-test to post-test for the experimental group but not for the control group. The experimental group experienced an increase in their communication skills from the pre-test to the post-test. The participants appeared to be able to act wisely and communicate effectively. By enhancing their communication skills, participants may display the ability to establish healthy relationships. The analysis suggested participants understood the importance of communicating clearly and honestly. Individuals were not afraid of expressing ideas in a direct manner while respecting another right to hear and respond. The results suggested that by participants enhancing their assertion competency skill, they were able to work more effectively in teams. Both aggression and deference considered potential problem areas however, the use of these two competencies converted from aggression and deference. Participants appeared to be able to channel anger and fear in a different manner. The result implied participants were able to communicate without being overpowering during verbal exchanges. Participants appeared to have developed a balance between anger and fear to communicate effectively during various situations. According to Emmitt and Gorse [34], combining the EI skills of empathy and assertion is a good approach for communicating effectively in stressful situations. Combining these key skills along with teaching aggression control and anxiety control would be excellent interventions and teaching goals of an EI curriculum.

## CONCLUSION

The research designed to investigate the influence of Emotional Intelligence Management Concepts Curriculum to improve construction manager's intrapersonal and interpersonal skills to impact leader behaviour. The research revealed that the EI intervention could integrated into a PBO curriculum to develop and improve the emotional learning process through a transformative education and skill-based approach to increase awareness and promote emotional self-control and healthy relationships. Introducing EI, skills offer positive advantages to project and career success. The findings suggest that teaching construction managers to use both the emotional and cognitive learning attributes are important for authentic learning to happen. The study charts an opportunity for improving both the cognitive and the emotional mind to increase project performance and enhance personal and social interactions.

## REFERENCES

- [1] L. Zhang, T. Cao, and Y. Wang, "The mediation role of leadership styles in integrated project collaboration: An emotional intelligence perspective," *International Journal of Project Management*, vol. 36, no. 2, pp. 317-330, 2018.
- [2] P. Khosravi, A. Rezvani, and N. M. J. I. J. o. P. M. Ashkanasy, "Emotional intelligence: A preventive strategy to manage destructive influence of conflict in large scale projects," vol. 38, no. 1, pp. 36-46, 2020.
- [3] A. Rezvani, A. Chang, A. Wiewiora, N. M. Ashkanasy, P. J. Jordan, and R. Zolin, "Manager emotional intelligence and project success: The mediating role of job satisfaction and trust," *International Journal of Project Management*, vol. 34, no. 7, pp. 1112-1122, 2016.
- [4] J. P. Stephens and A. Carmeli, "The positive effect of expressing negative emotions on knowledge creation capability and performance of project teams," *International Journal of Project Management*, vol. 34, no. 5, pp. 862-873, 2016.
- [5] G. Cowie, "The importance of people skills for project managers," *Industrial Commercial Training*, 2003.
- [6] A. Mazur, A. Pisarski, A. Chang, and N. Ashkanasy, "Rating defence major project success: The role of personal attributes and stakeholder relationships," *International Journal of Project Management*, vol. 32, no. 6, pp. 944-957, 2014.
- [7] R. Müller and R. J. I. J. o. p. m. Turner, "Leadership competency profiles of successful project managers," vol. 28, no. 5, pp. 437-448, 2010.
- [8] J. D. Mayer, R. D. Roberts, and S. G. J. A. R. P. Barsade, "Human abilities: Emotional intelligence," vol. 59, pp. 507-536, 2008.
- [9] N. Clarke, "Emotional Intelligence and Its Relationship to Transformational Leadership and Key Project Manager Competences," *Project Management Journal*, vol. 41, no. 2, pp. 5-20, 2010.
- [10] A. C. Troth, P. J. Jordan, S. A. Lawrence, and H. H. J. J. o. O. B. Tse, "A multilevel model of emotional skills, communication performance, and task performance in teams," vol. 33, no. 5, pp. 700-722, 2012.
- [11] R. Müller and R. Turner, "Leadership competency profiles of successful project managers," *International Journal of Project Management*, vol. 28, no. 5, pp. 437-448, 2010.
- [12] P. G. Northouse, *Leadership: Theory and practice*. Sage publications, 2018.
- [13] N. A. Zulkiffli and A. A. Latiffi, "Review on Project Manager's Leadership Skills in the Pre-Construction Phase of Sustainable Construction Projects," in *MATEC Web of Conferences*, 2019, vol. 266, p. 01011: EDP Sciences.
- [14] S. O. Ogunlana, "Critical COMs of success in large-scale construction projects: Evidence from Thailand construction industry," *International Journal of Project Management*, vol. 26, no. 4, pp. 420-430, 2008.
- [15] S. Pryke and H. J. T. m. o. c. p. A. r. a. Smyth, "Scoping a relationship approach to the management of complex projects in theory and practice," pp. 21-45, 2006.
- [16] S. U. R. Toor and S. Ogunlana, "Problems causing delays in major construction projects in Thailand," *Construction management economics*, vol. 26, no. 4, pp. 395-408, 2008.
- [17] L. B. Robichaud and V. Anantatmula, "Greening project management practices for sustainable construction," *Journal of management in engineering*, vol. 27, no. 1, pp. 48-57, 2011.
- [18] C. Butler and P. Chinowsky, "Emotional intelligence and leadership behavior in construction executives," *Journal of management in engineering*, vol. 22, no. 3, pp. 119-125, 2006.
- [19] R. Y. Sunindijo, B. H. Hadikusumo, and S. Ogunlana, "Emotional intelligence and leadership styles in construction project management," *Journal of management in engineering*, vol. 23, no. 4, pp. 166-170, 2007.
- [20] S. Rowlinson, T. K. Ho, Y. J. C. M. Po-Hung, and Economics, "Leadership style of construction managers in Hong Kong," vol. 11, no. 6, pp. 455-465, 1993.
- [21] C. H. Nam, C. B. J. C. M. Tatum, and Economics, "Leaders and champions for construction innovation," vol. 15, no. 3, pp. 259-270, 1997.
- [22] C. J. Butler and P. S. J. J. o. m. i. e. Chinowsky, "Emotional intelligence and leadership behavior in construction executives," vol. 22, no. 3, pp. 119-125, 2006.

- [23]B.-G. Hwang and W. J. Ng, "Project management knowledge and skills for green construction: Overcoming challenges," *International journal of project management*, vol. 31, no. 2, pp. 272-284, 2013.
- [24]A. Peled, "Politicking for success: the missing skill," *Leadership & Organization Development Journal*, vol. 21, no. 1, pp. 20-29, 2000.
- [25]H. Lingard and S. M. Rowlinson, *Occupational health and safety in construction project management*. Taylor & Francis, 2005.
- [26]J. M. Brill, M. J. Bishop, and A. E. Walker, "The Competencies and Characteristics Required of an Effective Project Manager: A Web-Based Delphi Study," *Educational Technology Research and Development*, vol. 54, no. 2, pp. 115-140, 2006/05/01 2006.
- [27]M.-I. Cheng, A. R. J. Dainty, and D. R. Moore, "What makes a good project manager?," vol. 15, no. 1, pp. 25-37, 2005.
- [28]R. Y. Sunindijo and B. H. W. Hadikusumo, "Emotional Intelligence for Managing Conflicts in the Sociocultural Norms of the Thai Construction Industry," *Journal of Management in Engineering*, vol. 30, no. 6, p. 04014025, 2014.
- [29]S. A. Davis, "Investigating the impact of project managers' emotional intelligence on their interpersonal competence," vol. 42, no. 4, pp. 37-57, 2011.
- [30]I. Pant and B. Baroudi, "Project management education: The human skills imperative," *International journal of project management*, vol. 26, no. 2, pp. 124-128, 2008.
- [31]D. B. Nelson and G. R. Low, *Emotional intelligence*. Boston: Prentice Hall, 2011.
- [32]D. Arditi and G. Balci, "Managerial competencies of female and male construction managers," *Journal of Construction Engineering and Management*, vol. 135, no. 11, pp. 1275-1278, 2009.
- [33]M.-y. Leung, I. Y. S. Chan, and C. Cooper, *Stress management in the construction industry*. John Wiley & Sons, 2014.
- [34]S. Emmitt and C. Gorse, *Communication in construction teams*. Routledge, 2006.

## ENVIRONMENTAL FACTORS AND SPREADING OF COVID-19 VIRION

**Hosam E.A.F. Bayoumi Hamuda<sup>1</sup>**

<sup>1</sup>Institute of Environmental Engineering and Natural Sciences, Óbuda University, Rejtő Sándor Faculty of Light Industry and Environmental Engineering, Budapest, Hungary  
E-mail: Bayoumi.hosam@uni-obuda.hu, Mobile: +36303900813

**Abstract:** The environmental sustainability in the context of the pandemic of COVID-19 has aroused widespread concern in the academic community. At present, there is a worldwide pandemic of COVID-19. With its associated morbidity and mortality, COVID-19 is on the track to become one of the most catastrophic pandemic health problems in human community. A considerable amount of research and publications have focused on the analysis of the meteorological and other environmental factors that lead to COVID-19 infection. After its person-to-person transmission was confirmed, the influence of environmental factors on COVID-19 transmission in human populations has received considerable attention. This study also shows the effects of various meteorological and other environmental factors which influences the spreading of COVID-19. Also, this research work aims to show the positive and negative indirect effects of COVID-19 on the environment, globally. This work illustrates that there is a significant association between contingency measures and improvement in air quality, clean beaches and environmental noise reduction. On the other hand, there are negative secondary aspects such as the reduction in recycling and the increase in waste, further endangering the contamination of physical spaces (e.g., in water and land), in addition to air. Global economic activity is expected to return in the coming months in most countries, so decreasing greenhouse gas concentrations during a short period is not a sustainable way to clean up our environment. In the case of the current pandemic, the implication of the personnel protective measures is only feasible if the community is well aware of the COVID-19 knowledge and responds positively towards the preventive e-guidelines by government. To combat the COVID-19, it is required that the people have the intention to adopt precautionary measures. However, the intention to adopt precautionary measures and risk aversion may be influenced by multiple factors. These factors include COVID-19 knowledge, behavioural control, moral and subject norms, preventive e-guidelines by the government, and environment.

Keywords: COVID-19, transmission, infection, environmental factors

### INTRODUCTION

Coronavirion (SARS-CoV-2 or COVID-19) belongs to a family of virions that might cause various complications like pneumonia, fever, breathing problems, and inflammation of the lungs. These virions are prevalent worldwide in animals, but very few cases have been known to affect humans. The term novel coronavirion 2019 was coined by the World Health Organization (WHO). The official reference name for the virion is severe acute respiratory syndrome coronavirion-2. A group of patients with pneumonia of unknown cause was reportedly related in December 2019 to a local Huanan South China Seafood Market in Wuhan, Hubei Province, China (Zhu et al. 2020).

COVID-19 is the third-largest in two decades of coronavirion infection identified initially in Asia, after extreme acute respiratory syndrome (SARS) and Middle East Respiratory Syndrome (MERS). Several significant clinical features of COVID-19 were reported. First, an attack rate of 83% is surprisingly high even within family context, suggesting the strong transmissibility of COVID-19. Second, with much more frequent signs and more extreme radiological abnormalities seen around elderly patients, the clinical manifestations of COVID-19 in this family vary from mild to moderate. In general, it appears that COVID-19 is less serious than SARS. Third, it was observed that an asymptomatic kid has ground-glass opacification in his lung and COVID-19 RNA in the sputum sample. This observation of asymptomatic virus shedding brings about the possibility of COVID-19 transfer from asymptomatic carriers to someone else, which is later confirmed by others (Bai et al. 2020). COVID-19 infection causes a systemic disease that is spread via airborne/droplets/aerosol. COVID-19 has indirectly affected humans, animal production, and the environment, and earth systems, social and economic conditions worldwide.

To reduce the pandemic spread of the virion, five measures have been adopted: (1) massive testing, (2) quarantine, (3) disinfection, (4) social distancing, and (5) sanitary measures. The occurrence,

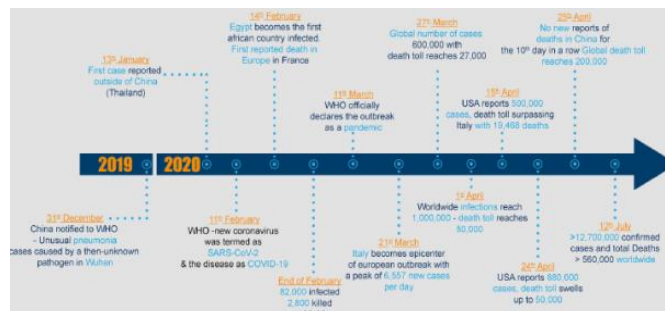


development, and prevention of COVID-19 illustrate the environmental impact of human diseases. Human activities have dramatically impacted the environment of earth. Modern human society has increased health and longevity, but has created the conditions for emergence of new pathogens and their rapid spread across the globe (El-Sayed et al. 2021).

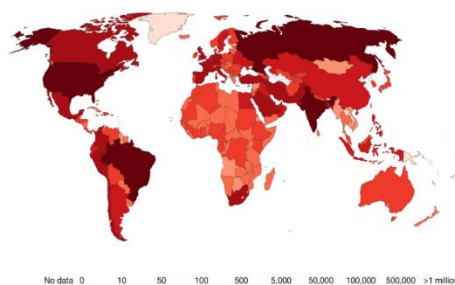
Population density, a topic that was rarely mentioned before, is directly linked to the spread of the COVID-19, which is transmitted from person-to-person, especially in close quarters. While human population density and their activities are directly related to the transmission of COVID-19, the relation between air pollution caused by humans and the spread of COVID-19 seems to be more complicated. Borisova & Komisarenko (2020) argue that the interaction of the COVID-19 envelope with air pollution particulate matter is possible in humid areas. The COVID-19 becomes a major threat to public health as well as the global economy, which also affects the lives of human beings. Coronavirions are enveloped viruses of the order Nidovirales harboring a single-stranded positive sense RNA genome. With approximately 31 kb, their genomes are the largest among RNA viruses (Masters & Perlman 2013). Coronavirions are genetically classified into four major genera: Alpha-, Beta-, Gamma-, and Deltacoronavirus (Li 2016).

The COVID-19 has caused a substantial number of deaths worldwide, posing a serious threat to public health in the world. Along with the implacable socio-economic impacts of this pandemic, the escalating mortality and morbidity is a problem. The WHO reports that the mortality rate was between 3 and 4% (Baud et al. 2020). From December 29, 2019, through July 21, 2020, COVID-19 infected 14,348,858 people globally, which results in 603,691 casualties with a mortality rate of 4.21% (WHO 2020). As of September 7, 2020, there have been 26,994,442 confirmed cases of COVID-19, including 880,994 deaths worldwide (<https://covid19.who.int/>). Figure (1a) shows the timeline spans December 31<sup>st</sup>, 2019, to July 12<sup>th</sup>, 2020. It shows the significant events related to the number of cases and deaths globally. As of July 12<sup>th</sup>, 2020, the representative world map shows the global distribution and the incidence of reported COVID-19 cases in each country (Figure 1b).

Coronavirions have large spherical structures with an average diameter of 120 nm, and they have a lipid bilayer envelope of about 80 nm and 20 nm long spikes (Yang & Wang 2020). The members of beta-coronavirion possess additional short-like protein called hemagglutinin esterase on their surfaces (Fehr & Perlman 2015). Interestingly, the structural proteins of the membrane, envelope, and the spike are anchored. In December 2019, COVID-19 emerged for the first time in China and has quickly-transmitted in the world (Angel-Korman et al. 2020). Currently, there are over 67 million confirmed COVID-19 cases throughout the globe, and this number is expected to escalate due to the highly contagious nature of the virus (Abdelhafez et al., 2021).



**Fig. 1a** Timeline of the global COVID-19 pandemic (Source: Machhi et al., 2020)



**Fig. 1b** Timeline of the global COVID-19 pandemic (Source: Machhi et al., 2020)

## MODE OF SPREADING, INFECTION AND REPLICATION OF COVID-19

COVID-19 infection rates and mortality rates in different states and territories of the USA are currently reported and updated daily. COVID-19 can be released into the surrounding air through patient's respiratory tract activities, and can exist for a long time for long-distance transportation. COVID-19 RNA can be detected in aerosol in different sites, including isolation ward, general ward, outdoor, toilet, hallway, and crowded public area. Environmental factors influencing were analyzed and indicated that the COVID-19 transportation in aerosol was dependent on temperature, air humidity, ventilation rate and inactivating chemicals (ozone) content (Jiang et al., 2021). Droplets of various sizes could spread respiratory infections. When the size of droplet particles is more than 5–10  $\mu\text{m}$  in diameter, they are referred to as respiratory droplets and are then referred to as droplet nuclei if they are less than 5  $\mu\text{m}$  in diameter.

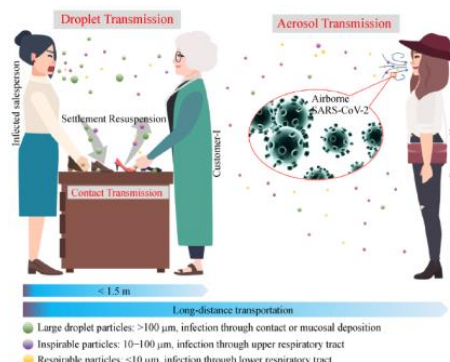
According to available data, the COVID-19 virus is transmitted primarily between humans via respiratory droplets and contact routes (Thompson, 2020). Droplet transmission occurs when a person is in close contact (within 1-m range) with someone who has respiratory symptoms (like coughing or sneezing), thus are at risk of exposure to potentially infectious respiratory droplets through his/her mucosa (mouth and nose) or conjunctiva (eyes). The transmission may also occur in surroundings around the infected person via fomites (Ong et al. 2020).

COVID-19 virion transmission may occur through direct contact with infected people or by indirect contact with surfaces in the immediate environment or with items used on the infected person (e.g., stethoscope or thermometer).

Airborne transmission is distinct from droplet transmission as it corresponds to the existence of microbes within droplet nuclei. They are usually called particles having a size less than 5  $\mu\text{m}$  in diameter that can remain in the atmosphere for more extended periods and can be transmitted to others over distances greater than 1 m. There is specific evidence that infection with COVID-19 can lead to bowel infection and can be found in feces. The rate of spread and mortality of COVID-19 widely varied across the globe.

Jiang et al. (2021) mentioned that during the close contact between virion carriers and susceptible population, droplet transmission and contact transmission may happen:

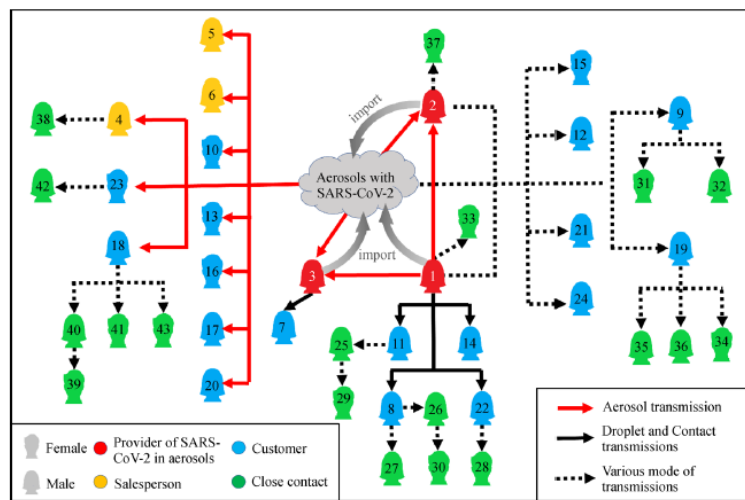
- 1) The large droplet particles have a better settling performance and relative strong pathogenicity, which could be easily inhaled by the susceptible population or deposit on the eyes, mouth or nasal mucosa thereby causing the susceptible population being sick by droplet transmission.
- 2) The susceptible population may contain the virion in their own hands by directly (contacting like, shaking hands) or indirectly (touching virion droplets deposited on the object's surface) ways, then, the virion travels through the hands and inoculates themselves into the mucous membranes (eyes, nose and mouth), causing an infection (Figure 2).



**Fig. 2.** The transmission of exhaled virus between infected and susceptible population (Source: Jiang et al., 2021)

Infected salesperson could release the virus into the environment by violent expiration (cough, sneeze, talk) or simply exhalation. Customer-I are infected through close encounter (occurred droplet

transmission or contact transmission). Customer-II is infected through sniffing airborne COVID-19 (aerosol transmission). The transportation distance of droplet particles usually less than 1.5 m. Inspirable and respirable particles could spread through the aerosol for long distances, while droplet particles could transform into inspirable or respirable by evaporation. Deposited droplet particles could be re-suspended through human activity and air agitation (Jiang et al., 2021). Nevertheless, patients in group 1 were infected through exposure to the aerosol and draw-in a number of COVID-19. Although the infectious characteristics of the incubation period of patients with COVID-19 were ambiguous, whether there was direct contact between sales persons and customers could be determined through exposure history analysis. Therefore, the transmission route of group 2 and 3 could be confirmed: there occurred in-plant or direct contact with an infection source in group 2; customers in group 3 did not provide their clear exposure area in the Baodi Department Store and close contacts may show various contact forms during their daily life (Figure 3).



**Fig. 3.** The transmission chain in salespersons, customers and their close contacts (Source: Jiang et al., 2021)

Case numbers 1, 2 and 3 are not only salespersons, but also providers of SARS-CoV-2 in aerosols. Group 1 consists of case numbers: 2–6, 10, 13, 16, 17, 18, 20 and 23. Group 2 is composed by case numbers: 7, 8, 11, 14 and 22. Group 3 is constituted by case numbers: 9, 12, 16, 15, 19, 21, 24 and from 27 to 43. As COVID-19 virion is human-to-human transmitted, it is a threat to the global population. It is critical to understand COVID-19 characteristics to deal with this ongoing pandemic and to develop future treatments. COVID-19 virion is an enveloped, positive-stranded RNA virion with a large genome (29.9 kb) belonging to the family Coronaviridae, order Nidovirales (De Wit et al., 2016). One of the striking genomic features of this novel virion is the presence of a novel furin-like cleavage site in the S-protein of the virion, which differs from SARS-CoV-1 and may have implications for the life cycle and pathogenicity of the novel virion (Coutard et al., 2020). Firstly, it was suggested that COVID-19 is a close relative of the RaTG13 bat-derived coronavirus (around 88% identity) rather than of SARS-CoV-1 (79% identity) or Middle East respiratory syndrome coronavirus MERS-CoV (50% identity) (Lu et al., 2020). Although bats are likely natural reservoir hosts for COVID-19, it was recently demonstrated that COVID-19 is closely related to a pangolin coronavirus (Pangolin-CoV) found in dead Malayan pangolins with a 91.02% identity, the closest relationship found so far for COVID-19 (Zhang et al., 2020).

In that study, genomic analyses revealed that the S1 protein of Pangolin-CoV is related closer to COVID-19 than to RaTG13 coronavirus. Also, five key amino acid residues involved in the interaction with the human ACE2 receptor are maintained in Pangolin-CoV and COVID-19, but not in RaTG13 coronavirus. Thus, it is likely pangolins are an intermediate host in the transmission of coronaviruses between bats and humans. In this manner, it was argued COVID-19 acquired mutations needed for human transmission and will continue to evolve with novel mutations, as the pandemic evolves (Zhang & Holmes, 2020). In this scenario, it is expected that diverse signatures of viral variants spread among different populations in the world. However, a mutational signature from USA

mutations was found in an Australian sample, suggesting a worldwide spread of this molecular signature consisting of five-point variants. As proof of the latter, a single nucleotide polymorphism in an Australian sample causes a bona-fide stop codon in the helicase protein. As genetic drift prompts the mutational spectrum of the virion, it was recommended frequently sequencing the viral pool in every country to detect the founder events relevant for COVID-19 testing in each population. So, it was found that the early mutational events in COVID-19 virion by analyzing sequencing samples from China, USA, Australia and GenBank sequences submitted between 27 March and 22 April 2020. COVID-19 variants from the USA display five-point mutations with clonal patterns of spreading at a considerably high frequency among samples. The efficiency of RT-qPCR testing can be potentially affected by founder variants, since several SNPs affecting one of three primers sets currently used in COVID-19 testing has been found. By the time of this publication, the available data could change the conclusions presented in this manuscript as a result of further viral variants arising (Farkas et al., 2020).

The virion present in the biggest aerial droplets penetrates the human organism adhering to the eye, nose, and mouth mucosae or even through contact with previously contaminated surfaces that are then concluded via touching the eyes, nose, and mouth (WHO 2020a). Leclerc et al. (2020) reported the possibility of COVID-19 transmission via aerosols, combined with transportation via droplets, primarily in restaurants (Lu et al. 2020) or in gym classrooms (Jang et al. 2020).

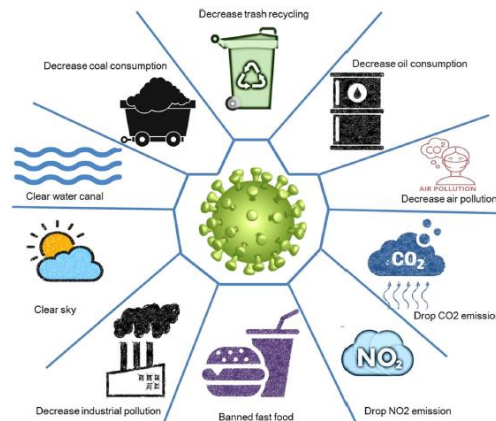
Transmission via short range aerosols cannot be disregarded, particularly in confined environments where there is high human density and inadequate ventilation, in case there are infected people for a prolonged time. There is a need for comprehension of the behavior of COVID-19 in the air using field data involving monitoring and detection of this virus in ambient air. The WHO (2020b) performed trials with the generation of aerosols from infectious samples using high potency jet nebulizers in controlled lab conditions. These papers revealed that the COVID-19 viral RNA remains in the air for up to 3 h (van Doremalen et al. 2020) and detected viruses with the capacity to replicate in 16 h (Fears et al. 2020).

## **INCUBATION PERIOD**

Generally, COVID-19 virion has an incubation period of 2–7 days. Although antibody-based detection methods are rapid, they are readily affected by factors, such as sample hemolysis, the presence of fibrin, bacterial contamination, and patient autoantibodies, resulting in a high false positive rate. Therefore, nucleic acid detection continues to be the gold standard for COVID-19 diagnosis, with several such methods having been employed for detection of the COVID-19 causative virion, COVID-19. Polymerase chain reaction (RT-qPCR) is currently the most popular testing method for detecting COVID-19. RT-qPCR is specific, rapid, and economic; however, it is unable to precisely analyze amplified gene fragment nucleic acid sequences. Thus, positive COVID-19 infection is confirmed by monitoring one or two sites. RT-qPCR exhibits high false-negative rates in clinical applications, which can facilitate infection transmission through delayed patient isolation and treatment, resulting in continued COVID-19 spread. The emergence of the new infectious disease COVID-19 is currently the most intriguing field of research for the entire scientific community around the world. Unlike other diseases, the gigantic effects of this pandemic go beyond the health dimension to have serious, even disastrous consequences on other areas, namely, the economic situation of the affected countries, the suspension of school and university activities, cultural, sporting events, etc. Virologically, COVID-19 is a new virion, not studied enough for virologists to give all the answers related to its spread mode. As a result, scientists from all disciplines such as biologists, physicists, chemists, mathematicians, and economists were intensively involved in the study of this pandemic in order to consolidate the epidemiologist's efforts. Early and accurate diagnosis of COVID-19 is of great importance for controlling the spread of the disease and to reduce its mortality. Emerging laboratory and epidemiological data suggest that environmental conditions may affect the current COVID-19 pandemic (Brassey et al. 2020).

## EFFECT OF METEOROLOGICAL FACTORS ON THE SPREAD OF COVID-19

Indeed, it was found that the effect of meteorological factors on the spread of COVID-19 is complex. While the general perception is that higher temperatures make virion less transmissible or less contagious, It was reported that COVID-19 cases and temperature showed a positive correlation, that the correlation between rainfall and COVID-19 cases was negative, and that that the increase in humidity was beneficial to stop the transmission of COVID-19. The influence of the COVID-19 pandemic on the environment is illustrated in Figure (4).



**Fig. 4.** The influence of the COVID-19 pandemic on the environment (Hafez et al., 2021)

Unfortunately, the work done by most countries to prevent and control the COVID-19 pandemic has fallen short. Reasons include the unprecedented scale of the COVID-19 pandemic, the high degree of infectiousness of COVID-19 and its rapid mutation rate, and its diverse means of transmission. However, research on prevention and control have led to public health interventions including maintaining social distancing, preventive e-guidelines and other educational tools, behavioural control on risk aversion, and surgical masks and sanitizers (Raza et al. 2020a,b). It is recognized that vitamins C, B6, and E and minerals such as zinc and magnesium have played and will continue to play vital roles in sustaining immune function during the COVID-19 pandemic. Despite the COVID-19 pandemic, global food prices have remained stable. According to the Center for Strategic International Studies, global prices only dropped 4.3% from February to March 2020 due to the demand for contractions amid lockdowns and quarantines (Welshans 2020). The COVID-19 spread was also reported in hot and humid conditions like Malaysia, Indonesia, and Singapore (Ahmadi et al. 2020). Meteorological indicators could affect environmental stability, which further influenced the viability of viruses. The humidity and temperature showed a significant impact on COVID-19 spread (Chen et al. 2020). In China, both relative humidity and temperature significantly influenced the transmission of COVID-19 (Wang et al. 2020a). Sajadi et al. (2020) mentioned that the nexus between temperature, humidity, and respiratory virions. The variations in the temperature and humidity also influenced the COVID-19 mortality (Ma et al. 2020). Prata et al. (2020) stated that it is hypothesized that variations in average temperature could significantly affect the COVID-19. Jahangiri et al. (2020) wrote that ambient temperature could be a crucial transmissibility factor behind COVID-19. Tosepu et al. (2020) explored the correlation between the COVID-19 pandemic and weather indicators (minimum temperature, maximum temperature, average temperature, and rainfall) in Jakarta, Indonesia. Spearman-rank correlation confirmed a significant correlation between COVID-19 and temperature. In Korea, the transmission of influenza was associated with relative humidity and low temperature. Studies also highlighted that COVID-19 was linked with meteorological factors. Şahin (2020) explored the linkages between COVID-19, population, and meteorological indicators (temperature, wind speed, dew point, and humidity) in Turkey. The Spearman's correlation confirmed the highest correlations score for population, temperature, and wind speed. Bashir et al. (2020) revealed the link among climate indicators (average temperature, average humidity, rainfall, air quality, and wind speed) and COVID-19 in New York, USA. Correlation statistics confirmed a significant link between climate conditions and COVID-19.

There is a connection between the novel coronavirus and climate (Wacker and Holick 2013). Meteorological variables are commonly considered crucial factors in the outbreak of infectious diseases. Some recent cited works examined the influences of meteorological indicators on COVID-19 spread over the globe in different locations including China (Shi et al. 2020; Liu et al. 2020; Xie and Zhu 2020; Ma et al. 2020), Iran (Ahmadi et al. 2020), Spain (Briz-Redón & Serrano-Aroca 2020), the USA (Runkle et al. 2020), Mexico (Méndez-Arriaga 2020), Turkey (Sahin 2020), Brazil (Auler et al. 2020), Indonesia (Tosepu et al. 2020), Singapore (Pani et al. 2020); Norway (Menebo 2020) and also global scale (Sobral et al. 2020; Wu et al. 2020). Moreover, the environmental factors drive the patterns of COVID-19 and found a relationship with meteorological indicators (Sajadi et al. 2020a). Published cited studies on COVID-19 have agreed that meteorological conditions may influence the COVID-19 outbreak (e.g., Tobías & Molina 2020). In addition to this, the WHO (2020a,b) also reported that more robust research works are needed to develop predicting models and to implement local health policies. Thus, a comprehensive study of COVID-19's meteorology dependency in various regions or cities is imperative to upsurge the current insights into its outbreak. Bangladesh is a well-known climate-vulnerable country due to its high population density and complex meteorological settings (Rahman & Islam 2019). As coronavirus can travel a certain distance through the air and can sustain in the air form a long time, there will be a sure influence of the meteorological factors over the transmission intensity of COVID-19. Contact transmission is the only process the virus affects one from another as the virus contagious only from droplets. Contact transmission refers to how many populations are likely affected by a single COVID-19 patient in a given environment. Dalziel et al. (2018) told that the transmission of viruses was influenced by various factors like humidity, temperature, and population density.

Epidemiological research revealed the linkages between meteorological indicators and COVID-19 but the findings were not clear (Wu et al. 2020). Dry or cold weather was favourable for viral diseases like influenza. The COVID-19 was mostly observed in the countries, located in low-temperature regions (Liu et al. 2020). The COVID-19 spread was normally observed in areas having low annual average temperatures (3–17°C). Chinese researchers mentioned the link between humidity, temperature, and COVID-19 outbreak. The COVID-19 spread was lower in warm and humid regions of China. Researchers from Finland and Spain reported that 95% of global infections take place between 2 and 10°C, and in dry climates.

## ENVIRONMENTAL FACTORS AND THE PANDEMIC COVID-19

The epidemiological dynamics of many infectious diseases depend upon environmental factors. The Severe Acute Respiratory Syndrome was linked with environmental factors (Sobral et al. 2020). Epidemiological research explored the association between coronavirus and meteorological indicators but the findings were not clear (Wu et al. 2020).

The environmental effects of the COVID-19 pandemic have received relatively little attention (Figure 5). The positive and negative impact of COVID-19 on the total environment, ecological sustainability, and earth systems have not yet been discussed.

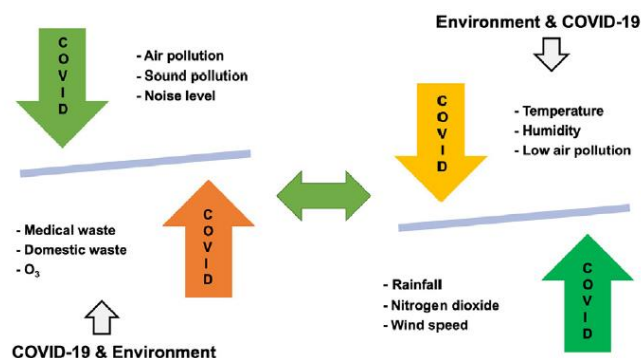


Fig. 5. Environmental factors have significant effect on COVID-19 transmission, and vice-versa (Sourc: Shakil et al., 2020).

Coronavirions named due to their spherical and pleomorphic outer fringe resembling crown belongs to the family of enveloped Ribonucleic acid (RNA) virions (Burrell et al. 2016). Some studies (e.g., Gale et al. 2010; Stott 2016) mentioned that climate change was linked with the emergence and spread of various infectious diseases. Literature showed that cold and dry weather is favorable for the transmission of droplet-mediated viral diseases like influenza. The COVID-19 pandemic was mostly observed in the countries, located in low-temperature regions (Liu et al. 2020).

Analyzing 166 countries, Wu et al. (2020) reported that the 1°C rise in temperature was responsible for 3.08% and 1.19% reduction in daily cases and daily deaths, respectively. On the other hand, 1% rise in relative humidity was responsible for 0.85% and 0.51% reduction in daily cases and daily deaths, respectively.

Several environmental factors, such as the nature of surfaces of objects and the role of transmission airborne infections, have attracted great attention from the public. Further systematic understanding of the impact of environmental factors on human-to-human transmission of this virus may be extremely important in designing measures to contain the COVID-19 epidemic (Bedford et al. 2020, Nakada & Urban 2020).

Among many environmental factors, population density is one of the conditions that cannot be underestimated and may affect the infection rate of COVID-19. Population density may directly reflect on whether and how social distancing and travel restriction work to slow the spread of COVID-19 (Gewin 2020; Gibson & Rush 2020). Theoretically, it was found that the higher the population density, the greater the chance of COVID-19 infection. However, it is still unclear to what extent population density affects the infection rate of COVID-19.

This pandemic has led to unexpected consequences, such as forced reductions in demands for industries, transportation systems, and all businesses due to public confinement; these declines have caused carbon emissions to drop and reduction in waste recycling. Other effects of the COVID-19 pandemic have been a drop in coal and oil consumption worldwide, a phenomenon that has contributed to a large-scale decline in air pollution. While this reduction is essential for environmental health in general, it also benefits individuals who contract COVID-19. Indeed, areas with higher air pollution have presented markedly higher mortality rates from COVID-19.

Governments in countries and regions around the world have taken mandatory precautions by using alcohol disinfectant, hand sanitizer, gloves, and masks to avoid the harm caused by COVID-19, especially vulnerable groups such as middle-aged and elderly people, children, and the infirm, which produces a large amount of medical waste and domestic garbage. If medical waste and domestic garbage are not handled properly, it will pollute the atmosphere, groundwater, surface water, and soil, which is not conducive to environmental supervision and sustainable development (Bashir et al. 2020). Medical waste and the trash from personal protective equipment, such as gloves and masks, are also on the rise. Some fast food and retail chains have banned the use of reusable cups and food containers. Thus, the oil industries have produced more plastics to mitigate financial losses. The generation of inorganic and organic waste has been increased due to the consumer's demand for online shopping and home delivery, and trash recycling has been reduced in many countries because of the concerns about the hazard of COVID-19 spreading in recycling centers (Zambrano-Monserrate et al. 2020). It is an unexpected major public health security incident, and it has the global characteristics of a wide range of infections, fast spreading speed, and difficult prevention and control. The outbreak of the COVID-19 pandemic has adversely affected all aspects of life and poses a severe threat to human health and economic development.

As of 1<sup>st</sup> of May 2021, the cumulative number of cases diagnosed with COVID-19 in the world was more than 153 million, whereas more than 3 million cases died (Coronavirus Update (Live): <https://www.worldometers.info/coronavirus> - Worldometer 2021). As a direct effect of the outbreak, more than 160 countries are fighting to combat the spread of COVID-19 and taking protective measures to save their citizens from the pandemic; at the same time, research institutes, drug corporations, biotechnology institutes, and research groups all over the world are racing to develop effective drugs or potential vaccines for COVID-19 (Sharpe et al. 2020; Thanh et al. 2020; Pooladanda et al. 2020; Hachfi and Ben Lasfar 2020; Mullard 2020; Biopharma products in development for COVID-19 2021).

The COVID-19 outbreak has not only significantly affected the supply chains of manufacturers and retailers around the world, the development of the tourism industry has been restricted, education

methods have begun to shift to online distance learning, and business organizations are paying more and more attention to the application of digitization and artificial intelligence, which has caused a great impact on global environmental conditions and supervision (Krishnamurthy 2020; Lee & Trimi 2021; Sharma et al. 2020; Sigala 2020; Verma & Gustafsson 2020). In response to this major public health incident, various countries and regions have implemented a series of control measures and adopted a closed management model to reduce contact between people.

The current available data in coronavirus infections provides an opportunity to conduct a preliminary analysis of the impact of population density on the infection rate of COVID-19. For example, the number of people infected in different cities with different population densities in China has been reported (Huang et al. 2020).

Lockdown measures have greatly reduced economic, industrial, and social activities, and therefore reduced various types of pollution emissions, and improved the global environment (Arora et al. 2020).

In addition, the emergency purchase of disposable products has increased production and consumption, thus hindering global efforts to reduce plastic pollution (Sarkodie & Owusu 2020). The occurrence and spread of COVID-19 are closely related to environmental issues such as air pollution and water pollution. A survey of global environmental conditions found that environmental conditions with suitable temperature, high air humidity and rainfall, and high air pollution are more conducive to the spread of COVID-19 (Ahmed & Ghanem 2020).

COVID-19 virION can survive for many days in untreated sewage. Some countries and regions with large populations but low sewage treatment facilities have a very high probability of being infected by the COVID-19 virus (Bhowmick et al. 2020). A low-temperature environment can prolong the activity of the COVID-19 virus. An investigation showed that the COVID-19 virus was detected in frozen and refrigerated food, and there were two repeated outbreaks of the epidemic related to contaminated food. This proves that COVID-19 can be spread through the contaminated food cold chain (Han et al. 2020).

The environmental sustainability in the context of the pandemic has aroused widespread concern in the global community. The COVID-19 pandemic was first discovered in Wuhan, China, in December 2019. The countries that reported COVID-19 cases first after the outbreak in China were Thailand, Japan, South Korea, Taiwan, and Vietnam, and then spread to most global countries and regions.

Since the outbreak of COVID-19, it has rapidly spread to most developing countries around the world, and the number of deaths from COVID-19 has gradually increased in developing countries such as India and Iran. Developing countries have resisted greater pressures on safety, health, and environmental protection, and have an urgent need to deal with this sudden challenge.

Most developing country governments and academics have learned lessons from this pandemic and plan for a transformation to create a greener and more resilient environment. The core of these transformations is to obtain timely high quality, classified data analysis and statistics, which will help the government to formulate effective and fair measures and policies (Editorial 2020).

To solve the root cause of COVID-19, it is clarify complex condition between the environment and the pandemic. By revealing their interaction, it can be better to prevent and control new infectious diseases (Chin et al. 2020). China and other developing countries were the first to be pressured by the safety, health, and environment under the influence of the COVID-19 pandemic.

The COVID-19 is stable for up to 4 h in copper surfaces, up to 24 h in cardboard, and between 2 and 3 days in plastic and stainless steel, according to the article by the National Institutes of Health (NIH, 2020), Centers for Disease Control & Prevention (CDC, 2019).

Scientists discovered that COVID-19 was detectable in aerosols. The results offer important data on COVID-19 stability and suggest that people may acquire the virus through the air, as well as by touching contaminated objects. Papers report on the mechanisms of its transportation, and there is evidence that this is a significant route of infection in indoor environments (Bae et al. 2020; Bourouiba 2020; Qureshi et al. 2020). Research results showed that long-term exposure to certain air pollutants can lead to more serious coronavirus infections and more difficult recovery. Berman & Ebisu (2020) assessed the air quality during the COVID-19 pandemic in the continental USs from January 8, 2017, to April 21, 2020. The countylevel pollution concentration during the historical period and the new crown pneumonia period was compared. Chen et al. (2020) used the attribution score method to estimate the daily specific cause-of-death mortality that China avoided during mass quarantine due to reduced air pollution.



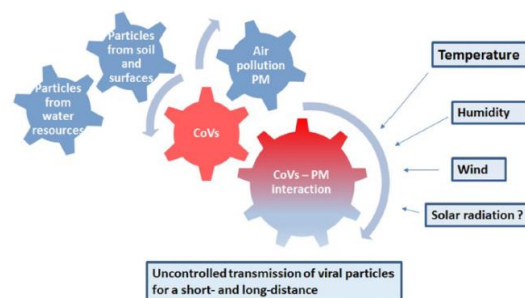
Le et al. (2020) found that during the outbreak of China's new crown pneumonia, air pollution was abnormal, and air pollution was alleviated. Wang et al. (2020) used the community multi-scale air quality model from January 1 to February 12, 2020, to study the changes in  $PM_{2.5}$  in 10 cities in China under the emission reduction scenario after the blocking the city of the epidemic. Wu et al. (2020) investigated the number of COVID-19 deaths in more than 3000 counties in the USA and the county-level  $PM_{2.5}$  long-term average, fitted a negative binomial mixed model, and performed more than 68 additional sensitivity analyses. It was found that with an increase of  $1\mu\text{g}/\text{m}^3 PM_{2.5}$ , the COVID-19 mortality rate increased by 8%. He et al. (2020) inferred the short-term impact of COVID-19 on air pollution in Chinese cities and used the difference model in difference to compare cities with and without lockdown policies. It was found that the city blockade had made a considerable improvement in air quality.

Contini & Costabile (2020) found that exposure to air pollution can increase vulnerability and adversely affect the prognosis of COVID-19 patients. Shehzad et al. (2020) discussed the effectiveness of COVID-19 on air pollution in Indian Territory from January to April 2020. By implementing an artificial neural network model, Magazzino et al. (2020) estimated a precise point in the neural transmission from  $PM_{10}$  and  $PM_{2.5}$  to the number of deaths due to COVID-19 in the three cities of Paris, Lyon, and Marseille in France. This point would describe the predictable concentration of particulate matter, which would lead to an increase in the number of deaths due to COVID-19. Singh et al. (2020) estimated the changes in six standard air pollutants during the national lockdown in India caused by the COVID-19 pandemic.

Perera et al. (2021) focused on the single particulate matter ( $PM_{2.5}$ ) during the COVID-19 shutdown. Pollutants are divided into two as primary and secondary pollutants. **Primary** pollutants are produced mainly by a process similar to a volcanic eruption, carbon monoxide released from motor vehicle exhaust, or sulfur dioxide released from industrial enterprises. Major primary pollutants are hydrogen sulfide,  $SO_2$ , CO,  $NO_x$ ,  $O_3$ , hydrocarbons,  $CO_2$ ,  $CH_4$ , lead, and volatile organic compounds (VOCs). **Secondary** pollutants are not released directly; instead, they are formed by the reaction or interaction of primary pollutants in the air. Ground-level  $O_3$  is an important example of secondary pollutants. Ground-level  $O_3$  has recently been one of the important parameters followed in terms of urban air pollution, especially in developed countries. In addition, peroxyacetyl nitrate, chlorofluorocarbons, formaldehyde, ammonium sulfate, and nitric acid are other important secondary pollutants (Masiol et al. 2017).

Does the concentration of air pollutants decrease during the lockdown? Does the air quality index improve during the lockdown? Comunian et al. (2020) analyzed the role of Italian particulate matter in the spread and increase of COVID-19 morbidity and mortality. Copat et al. (2020) systematically reviewed the literature on the relationship between some atmospheric pollutants ( $PM_{2.5}$ ,  $PM_{10}$ ,  $NO_2$ ) and the spread and mortality of COVID-19. Cole et al. (2020b) estimated the relationship between longterm air pollution exposure and COVID-19 in 355 municipalities in the Netherlands. Hendryx & Luo (2020) tested the relationship between long-term exposure to air pollutants, possible pollution sources, and the prevalence and mortality of COVID-19 in the USA as of May 31, 2020, through linear multiple regression analysis with mixed models.

Air pollution particulate matter (PM) and COVID-19 can form complex in water surrounding (Figure 6), where PM after drying can serve as a carrier for both short- and long-distance transportation of the virus, including outdoor and indoor one.



**Fig. 6.** Interaction of air pollution particulate matter with CoVs and uncontrolled transmission  
(Source: Borisova & Komisarenko, 2021)

Therefore, a possibility of unspecific interaction of COVID-19 envelope with air pollution PM and its transmission and transfection being immobilized at the PM surface were considered (Borisova and Komisarenko, 2021). Different envelope compositions and size of viruses can influence their capability and efficiency to form complex with PM. Despite the fact that PM concentrations in the air were decreased due to reduced anthropogenic activity during quarantine, residual PM can be enough to perform carrier service for COVID-19; moreover, exact virus infection doses are still not identified. Adams (2020) assessed the air pollution response in Ontario, Canada, during the COVID-19 emergency. Benmarhnia (2020) discussed the methodological challenges and opportunities for the link between air pollution and COVID-19, focusing on the role of air pollution as an influence modifier in the temporal and spatial variability of disease transmission and changes in the severity of symptoms and mortality.

Azuma et al. (2020) conducted a longitudinal cohort study on the potential relationship between the spread of COVID-19 infection and climate or ambient air pollution in 28 regions of Japan. Son et al. (2020) investigated the impact of COVID-19 mitigation measures on air pollution levels in 10 USs and the District of Columbia and subsequent decline in mortality.

Rahman et al. (2021) performed partial correlation analysis and linear mixed effect modelling to evaluate the association of the spread rate and motility of COVID-19 with maximum, minimum, average temperatures and diurnal temperature variation and other environmental and socioeconomic parameters.

After controlling the effect of the duration since the first positive case, partial correlation analysis revealed that temperature was not related with the spatial variability of the spread rate of COVID-19 at the global scale. Mortality was negatively related with temperature in the countries with high-income economies. In contrast, diurnal temperature variation was significantly and positively correlated with mortality in the low and middle-income countries. Taking the country heterogeneity into account, mixed effect modelling revealed that inclusion of temperature as a fixed factor in the model significantly improved model skill predicting mortality in the low- and middle-income countries.

The pandemic has already brought changes in social, economic, political, cultural and environmental aspects around the world. The first study which tested the effect of temperature and humidity on the COVID-19 associated with mortality reported that temperature had a positive link with the mortality in Wuhan, China (Ma et al. 2020).

Air quality of a city or region may be related with the health condition of the people of that region particularly the condition of respiratory system. Since the air quality index data were not available for all the countries authors took forested area, CO<sub>2</sub> emission, protected area percentage, number of threatened species as the proxies for air quality indicators. The specific management strategies such as lockdown, increased facilities for PCR testing may help tackle COVID-19 pandemic. Particularly, lockdown was found to suppress COVID-19 both in developed and developing countries (Atalan 2020; Shammi et al. 2020).

To control the spread and related fatalities, an immediate lockdown was imposed by many countries to minimize the movement of infected people and thereby to abate the adverse health effects. The lockdown resulted in reduced vehicular movements, stanchied construction activities and halted industrial operations resulting in reduced air pollution. Despite improvements in ambient air quality as reported in several studies, indoor air quality showed negligible improvement during the period of lockdown.

## **CONCLUSION**

Public health and the global economy faced huge problems due to COVID-19. The spread of the virion may be contained by maintaining proper social distance, personal hygiene, avoiding gatherings, and visiting places like hospitals, meetings, and public transportations, which have a high risk of such virus contamination. Furthermore, the transmission of the virus has been reported through the air in the form of aerosols causing widespread mortality. Based on the above literature review, it is of importance to correlate weather variables (including average daily temperature, maximum temperature, relative humidity, wind speed, pressure, and average daily solar radiation) to COVID-19 active cases. At the global level, most research institutions and scholars have taken the lead in

researching the impact of COVID-19 and its driving factors. As the disease was exponentially increasing from day to day basis; stakeholders like the regional health bureau and the zone health department as well as specific district health offices should give special attention to improve their knowledge and change the attitude towards prevention measures. Improving frontline community health workers' prevention status is basic to save other communities as a whole because their roles were totally within the community. Jimma zone health department and other stakeholders should give training for those who have not taken it yet and assess their status regularly.

Energy has suffered a huge impact, and advanced technologies such as artificial intelligence and big data can help decision makers, scientists, and health workers better understand the changes in environmental conditions during the COVID-19 pandemic, and play an important role. Therefore, governments in worldwide countries should learn from the pandemic and formulate relevant policies to maintain normal economic operations while maintaining good environmental quality conditions to reduce the possibility of an outbreak. In addition, policymakers should further adjust and improve the energy consumption structure, pay more attention to formulating policies with multilateral environmental constraints while strengthening R&D investment, and introduce strict environmental policies to promote the sustainable development of energy.

In addition, worldwide countries need to exchange and share knowledge, and learn from each other in the fields of artificial intelligence and big data, and also the experience and resources of on COVID-19 and environmental research to form a stable and global scientific research cooperation force, so as to jointly respond to the challenges of the COVID-19 pandemic and build a greener, environmentally sustainable world. This view provides a macro-system analysis of the global COVID-19 pandemic and environmental research, comprehensively assessing the research capabilities of COVID-19 and the environment in world countries, and policy recommendations for countries to meet the environmental challenges induced by the pandemic were offered. In addition, author recommend that future research further investigate the impact of big data and artificial intelligence on the environment during the COVID-19 pandemic and enrich the selected database.

## REFERENCES

- [1] Abdelhafez Eman, Dabbour Loai, Hamdan Mohammad (2021):: The effect of weather data on the spread of COVID-19 in Jordan. *Environmental Science and Pollution Research* (2021) 28:40416–40423. <https://doi.org/10.1007/s11356-020-12338-y>.
- [2] Adams M.D. (2020): Air pollution in Ontario, Canada during the COVID-19 State of Emergency. *Sci Total Environ* 742:140516.
- [3] Ahmadi M., Sharifi A., Dorosti S., Ghouschi S.J., Ghanbari N. (2020): Investigation of effective climatology parameters on COVID-19 outbreak in Iran. *Sci Total Environ* 729:138705. [<https://doi.org/10.1016/j.scitotenv.2020.138705>]
- [4] Ahmed A.T., Ghanem A.S. (2020): A statistical study for impacts of environmental conditions on the rapid spread of new corona virus. *Int J Environ Sci Technol* 17(10):4343–4352. <https://doi.org/10.1007/s13762-020-02858-y>.
- [5] Angel-Korman A., Brosh T., Glick K., Leiba A. (2020): COVID-19, the kidney and hypertension. *Harefuah*, 159: 231–234.
- [6] Arora S., Bhaukhandi K.D., Mishra P.K. (2020): Coronavirus lockdown helped the environment to bounce back. *Sci Total Environ* 742: 742. <https://doi.org/10.1016/j.scitotenv.2020.140573>
- [7] Atalan, A. (2020): Is the lockdown important to prevent the COVID-9 pandemic? Effects on psychology, environment and economy-perspective. *Annals of Medicine and Surgery*, 56, 38–42. <https://doi.org/10.1016/j.amsu.2020.06.010>.
- [8] Auler A.C., Cássaro F.A.M., da Silva V.O., Pires L.F. (2020): Evidence that high temperatures and intermediate relative humidity might favor the spread of COVID-19 in tropical climate: A case study for the most affected Brazilian cities. *Science of the Total Environment*, 729, 139090. <https://doi.org/10.1016/j.scito.tenv.2020.139090>.
- [9] Azuma K., Kagi N., Kim H., Hayashi M. (2020): Impact of climate and ambient air pollution on the epidemic growth during COVID-19 outbreak in Japan. *Environ Res* 190:110042.

- [10] Bae S., Kim M.C., Kim J.Y., Cha H.H., Lim J.S., Jung J., Kim M.J., Oh D.K., Lee M.K., Choi S.H., Sung M., Hong S.B., Chung J.W., Kim S.H. (2020): Effectiveness of surgical and cotton masks in blocking SARSCoV-2 a controlled comparison in 4 patients. *Ann Intern Med* 173:W22–W23. <https://doi.org/10.7326/M20-1342>.
- [11] Bai Y., Yao L., Wei T., Tian F., Jin D.Y., Chen L., Wang M. (2020): Presumed asymptomatic carrier transmission of COVID-19. *Jama* 323:1406–1407.
- [12] Bao R, Zhang A (2020): Does lockdown reduce air pollution? Evidence from 44 cities in northern China *Sci Total Environ.*, 731:139052. <https://doi.org/10.1016/j.scitotenv.2020.139052>
- [13] Bashir M.F., Ma B.J., Shahzad L. (2020): A brief review of socio-economic and environmental impact of Covid-19. *Air Qual Atmos Health* 13: 1403–1409. <https://doi.org/10.1007/s11869-020-00894-8>
- [14] Bashir M.F., Ma B., Bilal K.B., Bashir M.A., Tan D., Bashir M. (2020): Correlation between climate indicators and COVID-19 pandemic in New York, USA. *Sci Total Environ* 728:138835. <https://doi.org/10.1016/j.scitotenv.2020.138835>.
- [15] Baud D., Qi X., Nielsen-Saines K., Musso D., Pomar L., Favre G. (2020): Real estimates of mortality following COVID-19 infection. *Lancet., Infect. Dis.*, 20: 773. [https://doi.org/10.1016/S1473-3099\(20\)30195-X](https://doi.org/10.1016/S1473-3099(20)30195-X).
- [16] Bedford J., Enria D., Giesecke J., Heymann D.L., Ihekweazu C., Kobinger G., Lane H.C., Memish Z., Oh M.D., Sall A.A., Schuchat A., Ungchusak K., Wieler L.H. (2020): WHO strategic and technical advisory group for infectious hazards. COVID-19: towards controlling of a pandemic. *Lancet.*, 395(10229): 1015–1018.
- [17] Benmarhnia T. (2020): Linkages between air pollution and the health burden from COVID-19: methodological challenges and opportunities. *Am J Epidemiol* 189:1238–1243.
- [18] Berman J.D., Ebisu K. (2020): Changes in U.S. air pollution during the COVID-19 pandemic. *Sci Total Environ* 739:139864.
- [19] Bhowmick G.D., Dhar D., Nath D., Ghangrekar M.M., Banerjee R., Das S., Chatterjee J. (2020): Coronavirus disease 2019 (COVID-19) outbreak: some serious consequences with urban and rural water cycle. *Npj Clean Water*, 3(1). <https://doi.org/10.1038/s41545-020-0079-1>
- [20] Biopharma products in development for COVID-19 (2021): Available online at <https://www.bioworld.com/COVID19products>, updated on 1/14/2021, checked on 1/14/2021.
- [21] Borisova T., Komisarenko S. (2020): Air pollution particulate matter as a potential carrier of SARS-CoV-2 to the nervous system and/or neurological symptom enhancer: arguments in favor. *Environ. Sci. Pollut. Res. Int.*, 13: 1–7. <https://doi.org/10.1007/s11356-020-11183-3>
- [22] Borisova Tatiana, Komisarenko Serhiy (2021): Air pollution particulate matter as a potential carrier of SARS-CoV-2 to the nervous system and/or neurological symptom enhancer: arguments in favor. *Environmental Science and Pollution Research*, 28: 40371–40377. <https://doi.org/10.1007/s11356-020-11183-3>.
- [23] Brassey J., Heneghan C., Mahtani K.R., Aronson J.K. (2020): Do weather conditions influence the transmission of the coronavirus (SARSCoV-2)? Retrieved from <https://www.cebm.net/COVID-19/doweather-conditions-influence-the-transmission-of-the-coronavirussars-cov-2/>
- [24] Briz-Redón Á., Serrano-aroca Á. (2020): Science of the Total Environment A spatio-temporal analysis for exploring the effect of temperature on COVID-19 early evolution in Spain. *Sci Total Environ* 728:138811. <https://doi.org/10.1016/j.scitotenv.2020.138811>
- [25] Briz-Redón A., Serrano-Aroca A. (2020): A spatio-temporal analysis for exploring the effect of temperature on COVID-19 early evolution in Spain. *Science of the Total Environment*, 728, 138811. <https://doi.org/10.1016/j.scitotenv.2020.138811>
- [26] Burrell C., Howard C., Murphy F. (2016): *Fenner and White's Medical Virology*. Academic Press.

- [27] Centers for Disease Control and Prevention -CDC- (2019): COVID-19 and Animals. <https://www.cdc.gov/coronavirus/2019-ncov/daily-lifecoping/animals.html>. Accessed 30 August 2020.
- [28] Chen Yun, Guo Y., Pan Y., Zhao Z.J. (2020): Structure analysis of the receptor binding of 2019-nCoV. *Biochem Biophys Res Commun* 525:135–140.
- [29] Chen B., Liang H., Yuan X., Hu Y., Xu M., Zhao Y., Zhang B., Tian F., Zhu X. (2020) Roles of meteorological conditions in COVID-19 transmission on a worldwide scale. medRxiv. <https://doi.org/10.1101/2020.03.16.20037168>.
- [30] Chin A., Simon G.L., Anthamatten P., Kelsey K.C., Crawford B.R., Weaver A.J. (2020): Pandemics and the future of human-landscape interactions. *Anthropocene* 31:100256. <https://doi.org/10.1016/j.ancene.2020.100256>.
- [31] Cole M.A., Ozgen C., Strobl E. (2020b): Air Pollution Exposure and Covid-19. Department of Economics, University of Birmingham, Discussion Papers 20-13.
- [32] Coronavirus Update: 93,163,080 Cases and 1,993,578 Deaths from COVID-19 virus pandemic - Worldometer (2021). Available online at <https://www.worldometers.info/coronavirus/>, updated on 1/14/2021, checked on 1/14/2021.
- [33] Coutard B., Valle C., De Lamballerie X., Canard B., Seidah N.G., Decroly E. (2020): The spike glycoprotein of the new coronavirus 2019-nCoV contains a furin-like cleavage site absent in CoV of the same clade. *Antiviral Research* 176: 104742. DOI: 10.1016/j.antiviral.2020.104742
- [34] Comunian S., Dongo D., Milani C., Palestini P. (2020): Air pollution and COVID-19: the role of particulate matter in the spread and increase of COVID-19's morbidity and mortality. *Int J Environ Res Public Health* 17:4487.
- [35] Contini D., Costabile F. (2020): Does air pollution influence COVID-19 outbreaks? *Atmosphere* 11:377.
- [36] Copat C., Cristaldi A., Fiore M., Grasso A., Zuccarello P., Signorelli S.S., Conti G.O., Ferrante M. (2020): The role of air pollution (PM and NO<sub>2</sub>) in COVID-19 spread and lethality: a systematic review. *Environ Res* 191:110129.
- [37] Dalziel B.D., Kissler S., Gog J.R., Viboud C., Bjørnstad O.N., Metcalf C.J.E., Grenfell B.T. (2018): Urbanization and humidity shape the intensity of influenza epidemics in U.S. cities. *Sci* 362:75–79.
- [38] De Wit E, Van Doremalen N., Falzarano D., Munster V.J. (2016): SARS and MERS: recent insights into emerging coronaviruses. *Nature Reviews Microbiol.*, 14(8): 523-534.
- [439] Editorial (2020): Transition from pandemic. *Nat Sustain* 3(5):345–345. <https://doi.org/10.1038/s41893-020-0546-1>.
- [40] El-Sayed Amr, Aleya Lotfi, Kamel Mohamed (2021): COVID-19: a new emerging respiratory disease from the neurological perspective. *Environmental Science and Pollution Research* 28: 40445–40459. <https://doi.org/10.1007/s11356-021-12969-9>.
- [41] Farkas C., Fuentes-Villalobos F., Garrido J.L., Haigh J., Barría M.I.. (2020): Insights on early mutational events in SARS-CoV-2 virus reveal founder effects across geographical regions. *PeerJ* 8:e9255 <https://doi.org/10.7717/peerj.9255>
- [42] Fears A.C., Klimstra W.B., Duprex P., Hartman A., Weaver S.C., Plante K.S., Mirchandani D., Plante J.A., Aguilar P.V., Fernández D., Nalca A., Totura A., Dyer D., Kearney B., Lackemeyer M., Bohannon J.K., Johnson R., Garry R.F., Reed D.S., Roy C.J. (2020): Persistence of severe acute respiratory syndrome coronavirus 2 in aerosol suspensions. *Emerging Infectious Diseases*, 26(9):2168–2171. <https://doi.org/10.3201/eid2609.201806>
- [43] Fehr A.R., Perlman S. (2015): Coronaviruses: an overview of their replication and pathogenesis, coronaviruses. Springer, pp 1–23.
- [44] Gale P., Brouwer A., Ramnial V., Kelly L., Kosmider R., Fooks A.R., Snary E.L. (2010): Assessing the impact of climate change on vector-borne viruses in the EU through the elicitation of expert opinion. *Epidemiol Infect* 138(2): 214–225. <https://doi.org/10.1017/s0950268809990367>.
- [45] Gewin V. (2020 Apr): Safely conducting essential research in the face of COVID-19. *Nature*, 580(7804):549–550.
-

- [46] Gibson L., Rush D. (2020 Apr 6): Novel coronavirus in Cape Town informal settlements: feasibility of using informal dwelling outlines to identify high risk areas for COVID-19 transmission from a social distancing perspective. *JMIR Public Health Surveill.*, 6(2):e18844.
- [47] Hachfi W., Ben Lasfar N. (2020): COVID-19: Main therapeutic options. *La Tunisie medicale* 98(4):299–303.
- [48] Hafez M. Hafez, Attia A. Youssef, Bovera Fulvia, Abd El-Hack E. Mohamed, Khafaga F. Asmaa, de Oliveira Cristina Maria, (2021): Influence of COVID-19 on the poultry production and environment. *Environmental Science and Pollution Research* (2021) 28:44833–44844. <https://doi.org/10.1007/s11356-021-15052-5>.
- [49] Han J., Zhang X., He S.S., Jia .PQ. (2020): Can the coronavirus disease be transmitted from food? A review of evidence, risks, policies and knowledge gaps. *Environ Chem Lett* 19:5–16. <https://doi.org/10.1007/s10311-020-01101-x>.
- [50] He G., Pan Y., Tanaka T. (2020): The short-term impacts of COVID-19 lockdown on urban air pollution in China. *Nat Sustain* 3:1005–1011.
- [51] Hendryx M., Luo J. (2020): COVID-19 prevalence and fatality rates in association with air pollution emission concentrations and emission sources. *Environ Pollut* 265:115126.
- [52] Huang C., Wang Y., Li X., Ren L., Zhao J., Hu Y., Zhang L., Fan G., Xu J., Gu X., Cheng Z., Yu T., Xia J., Wei Y., Wu W., Xie X., Yin W., Li H., Liu M., Xiao Y., Gao H., Guo L., Xie J., Wang G., Jiang R., Gao Z., Jin Q., Wang J., Cao B. (2020): Clinical features of patients infected with 2019 novel coronavirus in Wuhan, China. *Lancet* 395:497–506. [https://doi.org/10.1016/S0140-736\(20\)30183-5](https://doi.org/10.1016/S0140-736(20)30183-5).
- [53] Jahangiri M., Jahangiri M., Najafgholipour M. (2020): The sensitivity and specificity analyses of ambient temperature and population size on the transmission rate of the novel coronavirus (COVID-19) in different provinces of Iran. *Sci Total Environ* 728:138872. <https://doi.org/10.1016/j.scitotenv.2020.138872>.
- [54] Jang S., Han S.H., Rhee J.Y. (2020): Cluster of coronavirus disease associated with fitness dance classes, South Korea. *Emerg Infect Dis* 26(8):1917–1920. <https://doi.org/10.3201/eid2608.200633>.
- [55] Jayaweera M, Perera H, Gunawardana B, Manatunge J (2020) Transmission of COVID-19 virus by droplets and aerosols: a critical review on the unresolved dichotomy. *Environ Res* 188:109819. <https://doi.org/10.1016/j.envres.2020.109819>
- [56] Jiang Guanyu, Wang Can Song Lu, Wang Xing, Zhou Yangyang, Fei Chunnan Liu He (2021): Aerosol transmission, an indispensable route of COVID-19 spread: case study of a department-store cluster. *Front. Environ. Sci. Eng.* 15(3): 46. <https://doi.org/10.1007/s11783-021-1386-6>.
- [57] John AL, Michael L, Z. Hugh Fan, Antarpreet SJ, Trevor BT, Mayank Gangwar, Moiz Usmani, Sripriya N Shankar, Karim Mohamed, Arantza Eiguren-Fernandez, Caroline J Stephenson, Md. Mahbubul Alam, Maha A Elbadry, Julia C Loeb, Kuttichantran Subramaniam, Thomas B Waltzek, Kartikeya Cherabuddi, John Glenn Morris, Chang-Yu Wu (2020) Viable SARS-CoV-2 in the air of a hospital room with COVID-19 patients. doi: <https://doi.org/10.1101/2020.08.03.20167395>.
- [58] Krishnamurthy S. (2020): The future of business education: a commentary in the shadow of the Covid-19 pandemic. *J. Bus. Res.*, 117:1–5. <https://doi.org/10.1016/j.jbusres.2020.05.034>.
- [59] Le T, Wang Y, Liu L, Yang J, Yung YL, Li G, Seinfeld JH (2020) Unexpected air pollution with marked emission reductions during the COVID-19 outbreak in China. *Science* 369:702–706
- [60] Lee S.M., Trimi S. (2021): Convergence innovation in the digital age and in the COVID-19 pandemic crisis. *J Bus Res* 123:14–22. <https://doi.org/10.1016/j.jbusres.2020.09.041>.
- [61] Leclerc Q.J., Fuller N.M., Knight L.E., Funk S., Knight L.E., CMMID COVID-19 Working Group, Funk S., Knight G.M. (2020): What settings have been linked to SARS-CoV-2 transmission clusters? *Wellcome Open Res* 5:83. <https://doi.org/10.12688/wellcomeopenres.15889.2>.
-

- [62] Liu J., Zhou J., Yao J., Zhang X., Li L., Xu X., He X., Wang B., Fu S., Niu T., Yan J., Shi Y., Ren X., Niu J., Zhu W., Li S., Luo B., Zhang K. (2020): Impact of meteorological factors on the COVID-19 transmission: a multicity study in China. *Sci Total Environ* 726:138513. <https://doi.org/10.1016/j.scitotenv.2020.138513>.
- [63] Liu M., Tan S., Zhang M., He G., Chen Z., Fu Z., Luan C. (2020): Waste paper recycling decision system based on material flow analysis and life cycle assessment: a case study of waste paper recycling from China. *J. Environ. Manag.*, 255: 109859.
- [64] Li F. (2016): Structure, function, and evolution of coronavirus spike proteins. *Annu. Rev. Virol.* 3: 237–261.
- [65] Lu R., Zhao X., Li J., Niu P., Yang B., Wu H., Wang W., Song H., Huang B., Zhu N. et al. (2020): Genomic characterisation and epidemiology of 2019 novel coronavirus: implications for virus origins and receptor binding. *Lancet.*, 395(10224):565-574.
- [66] Ma, Y., Zhao, Y., Liu, J., He, X., Wang, B., Fu, S., et al. (2020): Effects of temperature variation and humidity on the death of COVID-19 in Wuhan, China. *Science of The Total Environment*, 724, 138226. <https://doi.org/10.1016/j.scitotenv.2020.138226>.
- [67] Machhi Jatin, Herskovitz Jonathan, Senan M. Ahmed, Dutta Debashis, Nath Barnali, Oleynikov D. Maxim, Blomberg R. Wilson, Meigs D.D., Hasan Mahmudul, Patel Milankumar, Kline Peter, Chang Chuen-Chung Raymond, Chang Linda, Gendelman E. Howard, Kevadiya D. Bhavesh (2020): The Natural History, Pathobiology, and Clinical Manifestations of SARS-CoV-2 Infections. *J. Neuroimmune. Pharmacol.*, 15: 359–386. <https://doi.org/10.1007/s11481-020-09944-5>.
- [68] Magazzino C., Mele M., Schneider N. (2020): The relationship between air pollution and COVID-19-related deaths: an application to three French cities. *Appl Energy* 279:115835
- [69] Masters P.S., Perlman S. (2013): Coronaviridae. In: Knipe DM, Howley P (eds) *Fields virology*. Lippincott Williams and Wilkins, Philadelphia, PA, pp 825–858.
- [70] Méndez-Arriaga F. (2020): The temperature and regional climate effects on communitarian COVID-19 contagion in Mexico throughout phase 1. *Science of the Total Environment*. <https://doi.org/10.1016/j.scitotenv.2020.139560>.
- [71] Menebo M.M. (2020): Temperature and precipitation associate with Covid-19 new daily cases: A correlation study between weather and Covid-19 pandemic in Oslo, Norway. *Science of the Total Environment*, 737: 139659. <https://doi.org/10.1016/j.scitotenv.2020.139659>.
- [72] Mullard A. (2020): Flooded by the torrent: the COVID-19 drug pipeline. In *Lancet* (London, England) 395(10232): 1245–1246. [https://doi.org/10.1016/S0140-6736\(20\)30894-1](https://doi.org/10.1016/S0140-6736(20)30894-1).
- [73] Nakada L.Y.K., Urban R.C. (2020 Sep 28): COVID-19 pandemic: environmental and social factors influencing the spread of SARS-CoV-2 in Sao Paulo. Brazil. *Environ Sci Pollut Res Int.*:1–7. <https://doi.org/10.1007/s11356-020-10930-w>.
- [74] National Institutes of Health- NIH (2020): New coronavirus stable for hours on surfaces. <https://www.nih.gov/news-events/news-releases/new-coronavirus-stable-hours-surfaces>. Acces -sed 26 August 2020.
- [75] Ong S.W.X., Tan Y.K., Chia P.Y., Lee T.H., Ng O.T., Wong M.S.Y., Marimuthu K. (2020): Air, surface environmental, and personal protective equipment contamination by severe acute respiratory syndrome coronavirus 2 (SARS-CoV-2) from a symptomatic patient. *Jama* 323: 1610–1612.
- [76] Pani S.K., Lin N.H., RavindraBabu S. (2020): Association of COVID-19 pandemic with meteorological parameters over Singapore. *Science of the Total Environment*. <https://doi.org/10.1016/j.scitotenv.2020.140112>.
- [77] Pooladanda V., Thatikonda S., Godugu C. (2020): The current understanding and potential therapeutic options to combat COVID-19. In *Life sciences* 254:117765. <https://doi.org/10.1016/j.lfs.2020.117765>
- [78] Prata D.N., Rodrigues W., Bermejo P.H. (2020): Temperature significantly changes COVID-19 transmission in (sub) tropical cities of Brazil. *Sci Total Environ* 729:138862. <https://doi.org/10.1016/j.scitotenv.2020.138862>.

- [79] Qureshi Z., Jones N., Temple R., Larwood J.P.J., Greenhalgh T., Bourouiba L. (2020): What is the evidence to support the 2-metre social distancing rule to reduce COVID-19 transmission? The Centre for Evidence-Based Medicine develops, promotes and disseminates better evidence for healthcare. <https://www.cebm.net/covid-19/what-is-the-evidence-to-support-the-2-metre-social-distancing-rule-to-reduce-covid-19-transmission/>. Accessed 17 August 2020.
- [80] Rahman M.S., Islam A.R.M.T. (2019): Are precipitation concentration and intensity changing in Bangladesh overtimes? Analysis of the possible causes of changes in precipitation systems. *Sci. Total Environment*, 690, 370–387. <https://doi.org/10.1016/j.scitotenv.2019.06.529>.
- [81] Rahman Mizanur, Islam Mahmuda, Shimanto Hasan Mehedi, Ferdous Jannatul, Rahman Al-Nur Shanto Abdullah, Sagor Singha Pabitra, Chowdhury Tahasina (2021): A global analysis on the effect of temperature, socio-economic and environmental factors on the spread and mortality rate of the COVID-19 pandemic. *Environment, Development and Sustainability* (2021) 23:9352–9366. <https://doi.org/10.1007/s10668-020-01028-x>
- [82] Runkle J.D., Sugg M.M., Leeper R.D., Rao Y., Matthews J.L., Rennie J.J. (2020): Short-term effects of specific humidity and temperature on COVID-19 morbidity in select US cities. *Science of the Total Environment*, 740, 140093. <https://doi.org/10.1016/j.scitotenv.2020.140093>.
- [83] Raza A., Ali Q., Hussain T. (2020a): Role of knowledge, behavior, norms, and e-guidelines in controlling the spread of COVID-19: evidence from Pakistan. *Environ Sci Pollut Res Int* 4:1–17. <https://doi.org/10.1007/s11356-020-10931-9>.
- [84] Raza A., Khan M.T.I., Ali Q., Hussain T., Narjis S. (2020b): Association between meteorological indicators and covid-19 pandemic in Pakistan. *Environ Sci Pollut Res Int* 14:1–16. <https://doi.org/10.1007/s11356-020-11203-2>.
- [85] Şahin M. (2020): Impact of weather on COVID-19 pandemic in Turkey. *Sci Total Environ* 728:138810. <https://doi.org/10.1016/j.scitotenv.2020.138810>
- [86] Sajadi M.M., Habibzadeh P., Vintzileos A., Shokouhi S., Miralles-Wilhelm F., Amoroso A. (2020): Temperature and latitude analysis to predict potential spread and seasonality for COVID-19. Available at SSRN 3550308
- [87] Sarkodie S.A., Owusu P.A. (2020): Impact of COVID-19 pandemic on waste management. *Environ Dev Sustain*. <https://doi.org/10.1007/s10668-020-00956-y>
- [88] Shakil Hassan Mohammad, Munim Haque Ziaul, Tasnia Mashiyat, Sarowar Shahin (2020): COVID-19 and the environment (2020): A critical review and research agenda. *Science of the Total Environment* 745: 141022. <https://doi.org/10.1016/j.scitotenv.2020.141022>
- [89] Shammi, M., Bodrud-Doza, M., Islam, A. R. M. T., Rahman, M. M. (2020): Strategic assessment of COVID-19 pandemic in Bangladesh: Comparative lockdown scenario analysis, public perception, and management for sustainability. *Environment, Development and Sustainability*. <https://doi.org/10.1007/s10668-020-00867-y>.
- [90] Sharma A., Adhikary A., Borah S.B. (2020): Covid-19's impact on supply chain decisions: strategic insights from NASDAQ 100 firms using Twitter data. *J Bus Res* 117:443–449. <https://doi.org/10.1016/j.jbusres.2020.05.035>.
- [91] Sharpe H.R., Gilbride C., Allen E., Belij-Rammerstorfer S., Bissett C., Ewer K., Lambe T. (2020): The early landscape of COVID-19 vaccine development in the UK and rest of the world. *Immunology* 160: 223–232. <https://doi.org/10.1111/imm.13222>.
- [92] Shehzad K., Sarfraz M., Shah S.G.M. (2020): The impact of COVID-19 as a necessary evil on air pollution in India during the lockdown. *Environ Pollut* 266:115080
- [93] Shi P., Dong Y., Yan H., Li X., Zhao C., Liu W., et al. (2020): The impact of temperature and absolute humidity on the coronavirus disease 2019 (COVID-19) outbreak—Evidence from China. *medRxiv*. <https://doi.org/10.1101/2020.03.22.20038919>.



- [94] Shi P., Dong Y., Yan H., Zhao C., Li X., Liu W., He M., Tang S., Xi S. (2020): Impact of temperature on the dynamics of the COVID-19 outbreak in China. *Sci Total Environ* 728:138890. <https://doi.org/10.1016/j.scitotenv.2020.138890>.
- [95] Sigala M. (2020): Tourism and COVID-19: impacts and implications for advancing and resetting industry and research. *J Bus Res* 117:312–321. <https://doi.org/10.1016/j.jbusres.2020.06.015>.
- [96] Singh V., Singh S., Biswal A., Kesarkar A.P., Mor S., Ravindra K. (2020): Diurnal and temporal changes in air pollution during COVID-19 strict lockdown over different regions of India. *Environ Pollut* 266:115368.
- [97] Sobral M.F.F., Duarte G.B., Sobral A.I.G.D.P., Marinho M.L.M., Melo A.D.S. (2020): Association between climate variables and global transmission of SARS-CoV-2. *Sci Total Environ* 729:138997. <https://doi.org/10.1016/j.scitotenv.2020.138997>.
- [98] Son J.-Y., Fong K.C., Heo S., Kim H., Lim C.C., Bell M.L. (2020): Reductions in mortality resulting from reduced air pollution levels due to COVID-19 mitigation measures. *Sci Total Environ* 744:141012.
- [99] Stott P. (2016): Climate Change. How climate change affects extreme weather events. *Sci* 352(6293):1517–1518. <https://doi.org/10.1126/science.aaf7271>.
- [100] Thanh Le T., Andreadakis Z., Kumar A., Román G., Raúl, Tollefsen S., Saville M., Mayhew S. (2020): The COVID-19 vaccine development landscape. In *Nat Rev Drug Discov* 19(5):305–306. <https://doi.org/10.1038/d41573-020-00073-5>.
- [101] Thompson R. (2020): Pandemic potential of 2019-nCoV. *Lancet Infect Dis* 20:280
- [102] Tobías A., Molina T. (2020): Is temperature reducing the transmission of COVID-19? *Environmental Research*, 186: 109553. <https://doi.org/10.1016/j.envres.2020.109553>.
- [103] Tosepu R., Gunawan J., Effendy D.S., Ahmad L.O.A.I., Lestari H., Bahar H., Asfian P. (2020): Correlation between weather and Covid-19 pandemic in Jakarta, Indonesia. *Sci Total Environ* 725:138436. <https://doi.org/10.1016/j.scitotenv.2020.138436>
- [104] van Doremalen N., Bushmaker T., Morris D.H., Holbrook M.G., Gamble A., Williamson B.N., Tamin A., Harcourt J.L., Thornburg N.J., Gerber S.I., Lloyd-Smith J.O., de Wit E., Munster V.J. (2020): Aerosol and surface stability of SARS-CoV-2 as compared with SARS-CoV-1. *N Engl. J. Med.*, 382: 1564–1567. <https://doi.org/10.2807/1560-7917.es2013.18.38.20590>
- [105] Verma S., Gustafsson A. (2020): Investigating the emerging COVID-19 research trends in the field of business and management: a bibliometric analysis approach. *J Bus Res* 118:253–261. <https://doi.org/10.1016/j.jbusres.2020.06.057>.
- [106] Wacker M., Holick M.F. (2013): Sunlight and Vitamin D: A global perspective for health. *Dermatoendocrinol.*, 5(1), 51–108. <https://doi.org/10.4161/derm.24494>.
- [107] Wang J., Tang K., Feng K., Lv W. (2020a). High temperature and high humidity reduce the transmission of COVID-19. Available at SSRN 3551767.
- [108] Wang P., Chen K., Zhu S., Wang P., Zhang H. (2020): Severe air pollution events not avoided by reduced anthropogenic activities during COVID-19 outbreak *Resources. Conserv Recycl* 158:104814.
- [109] Welshans K. (2020): Meat sales, consumption surge amid COVID-19 disruption. <https://www.supermarketnews.com/meat/meat-salesconsumption-surge-amid-COVID-19-disruption>. Accessed June 22, 2020.
- [110] World Health Organization (2020): World Health Organization. <https://www.who.int/emergencies/diseases/novel-coronavirus-2019/situation-reports/>, Accessed date: 04 Oct 2020
- [120] World Health Organization-WHO (2020): Coronavirus disease (COVID-19) Situation Report-194
- [111] World Health Organization (2020) WHO Director-General’s remarks at the media briefing on 2019-nCoV on 11 February 2020. <https://www.who.int/dg/speeches/detail/who-director-general-s-remarks-at-the-media-briefing-on-2019-ncov-on-11-february-2020>.
- [112] World Health Organization (2020): Coronavirus disease (COVID-19) pandemic. <https://www.who.int/emergencies/diseases/novel-coronavirus-2019/situation-reports/>.

- [113] World Health Organization (2020a) Surface sampling of coronavirus disease (COVID-19): a practical “how to” protocol for health care and public health professionals. [https://www.who.int/publications/i/item/surface-sampling-of-coronavirus-disease-\(covid-19\)-a-practical-how-to-protocol-for-health-care-and-public-health-professionals](https://www.who.int/publications/i/item/surface-sampling-of-coronavirus-disease-(covid-19)-a-practical-how-to-protocol-for-health-care-and-public-health-professionals). Accessed 12 August 2020
- [114] World Health Organization (2020b) Transmission of SARS-CoV-2: implications for infection prevention precautions. <https://www.who.int/news-room/commentaries/detail/transmission-of-sars-cov-2-implications-for-infection-prevention-precautions>. Accessed 12 August 2020
- [115] Wu, J. T., Leung, K., Leung, G. M. (2020): Now casting and forecasting the potential domestic and international spread of the 2019-nCoV outbreak originating in Wuhan, China: A modelling study. *Lancet*, 395(10225), 689–697
- [116] Wu Y, Jing W, Liu J, Ma Q, Yuan J, Wang Y, Du M, Liu M (2020) Effects of temperature and humidity on the daily new cases and new deaths of COVID-19 in 166 countries. *Sci Total Environ* 729: 139051. <https://doi.org/10.1016/j.scitotenv.2020.139051>
- [117] Xie J., Zhu Y.. (2020): Association between ambient temperature and COVID-19 infection in 122 cities from China. *Science of the Total Environment*, 724, 138201. <https://doi.org/10.1016/j.scitotenv.2020.138201>.
- [118] Yang P., Wang X. (2020): COVID-19: a new challenge for human beings. *Cell Mol Immunol*
- [119] Zambrano-Monserrate A.M., Ruano Alejandra María, Sanchez-Alcalde Luis (2020): Indirect effects of COVID-19 on the environment. *Science of the Total Environment* 728: 138813. <https://doi.org/10.1016/j.scitotenv.2020.138813>.
- [120] Zhang T., Wu Q., Zhang Z. (2020): Probable pangolin origin of SARS-CoV-2 associated with the COVID-19 outbreak. *Current Biology* 30(7): 1346-1351.
- [121] Zhang Y.Z., Holmes E.C. (2020): A genomic perspective on the origin and emergence of SARS-CoV-2. *Cell* 181(2):223-227.
- [122] Zhang D., Jiang S., Shi Z., Tan W., Lu H., Cao B., Zhang W., Liu S., Zhong J, Xiao G., Xie Y., Deng K., Zhao J., Yang Z., Song J., Lu L., Huang J., Ying T., Wang Q., Shi M., Xu J., An J., Lu F., Gao F., Shu Y., Guo D. (2020): Consideration and suggestion for naming the novel coronavirus. *China Terminol* 22: 5–10.
- [123] Zhu N., Zhang D., Wang W., Li X., Yang B., Song J., Zhao X., Huang B., Shi W., Lu R., Niu P., Zhan F., Ma X., Wang D., Xu W., Wu G., Gao G.F., Tan W. (2020): A novel coronavirus from patients with pneumonia in China, 2019. *N. Engl. J. Med.*, 382: 727–733.



**XI International Conference Industrial  
Engineering and Environmental  
Protection 2021 (IIZS 2021)  
October 07-08, 2021, Zrenjanin, Serbia**

---

# **I - Industrial Engineering**

Session 1:  
**Mechanical Engineering**

## NEW CONCEPT HAZELNUT UNSHELLING APPARATUS

Mukrimin S. Guney<sup>1</sup>

<sup>1</sup>University of Giresun, Engineering Faculty, Mechanical Engineering, Giresun, Turkey  
e-mail: [guney80@gmail.com](mailto:guney80@gmail.com) , [MS.guney@giresun.edu.tr](mailto:MS.guney@giresun.edu.tr)

**Abstract:** Hazelnut is an important agricultural product in the world with an annual production of one million tons and a value of 3 billion dollars. It is an indispensable product in the chocolate industry and is widely used. Crushing and roasting processes are widely applied. crushing process is done with huge capacity in stone mill systems. This is an obstacle to the existence of small and medium-sized enterprises in the sector. This work represents a new concept and approach to hazelnut crushing/unshelling systems suitable for domestic use and for different size enterprises.

**Keywords:** hazelnut, crushing, new concept, enterprise

### INTRODUCTION

Hazelnut is a recommended food for balanced and healthy nutrition [1]. It is also preferred to be consumed as snacks [2]. It can be found up to 26% in the contents of chocolates, depending on their style and brand [3]. Shell crushing methods in nuts can be classified as crushing by impact, crushing by compression force, breaking by vacuum pressure, breaking by cutting with hard thin blades, crushing by crushing and rubbing, and by throwing and knocking [4].

For the improvement of process efficiency is necessary to handle all the processing steps from storage to packaging. This is a rational approach for high added value nuts and hazelnut products in industrial plants [5]. The necessary improvements to ensure this quality and efficiency can be achieved by reducing the cost of the hazelnut shelling process, which is the first step in the production by extracting the kernel from the shell. In addition to reduce initial investment and maintenance costs, the development of such systems those will also reduce the rate of impacted hazelnut will bring positive results on industry.

By industrial applications, the unshelling/crushing process is generally carried out in stone mills up to 120 cm in diameter. These mills also have upper stone and lower stone. The upper stone is made with hole in the middle so that the shelled hazelnuts can pass into the mill crushing basin. In addition, the upper stone lower surface is formed in the form of a jaw in order to fulfill its crushing function. The upper stone jaw can move up and down with a screwed movement mechanism in order to adjust the gap. The bottom stone is rotated at certain speeds via of an electric motor. The hazelnuts, which reach the unshelling operation part/point by falling from above, are forced to pass through the jaw which is smaller gap size comparing with kernel diameter by being thrown through this rotational movement and due to centrifugal forces and drag effects in the air beam. Just the time the crushing/unshelling process also takes place. Another important equipment in the system is the diameter sizing sieves. Diameter sizing sieves are made by means of rotating cylindrical drums of circular cross section. These drums are generally 6 meters long by folding the perforated sheets in succession and gradually increasing the hole diameters and splicing them together in widths of 50 cm. Such traditional systems are large-scale and cumbersome in nature. There are also pre-storage requirements before entering the grading drums. In addition, unshelled hazelnut kernels must have been stored in suitable sized chambers where they fall along the axis of the grading drums. The vertical lengths of these chambers are quite large compared to other dimensions. Elevator-like transport equipment is also required for the system to complete its function. These transporting equipment's primarily ensure that the hazelnuts, which are sorted by length and kept in suitable chambers, are transmitted from the front storage to the grading drums, and secondarily, to the upper parts of the crushing mills. In such traditional systems, the crushing jaw must be preset according to the diameter of the hazelnuts to be sent to the mill. They are large-scale systems that require huge storage, stocking and installation areas, with capacities of 1000-2000 kg/h per crushed stone. These systems are bulky and require huge

volumes. It is also not suitable for small businesses. It is important to develop processes and systems that create competition and use energy effectively.

## MATERIAL AND METHODS

Therefore, such systems are suitable for large-scale companies. It is an important obstacle for small and medium-sized enterprises to exist in the sector. This weakens competition and may prevent desired reductions in product processing costs. In recent years, micro-scale stone crushing mills have been developed. In this type of micro crusher mills, there are grading rollers just above the crushing mills. In the structure consisting of two nested cylinders, slit spacing can be increased by moving one of the cylinders on the horizontal axis. In accordance with this range, the jaw crushing width is adjusted simultaneously with the stepper motor mechanism. These systems require complex software and precision engines. Therefore, initial investment costs appear as an important parameter.

The new type of crushing system developed and proposed by the author of this article is especially suitable for small boutique businesses. It offers significant reductions in storage areas and product transport systems. They are compact systems that can easily adapt to environmental technologies that use energy and space effectively. It performs the crushing/unshelling process simultaneously with the diameter sizing or magnitude sorting. It does not need complex software and such systems as stepping motors, which are advanced technology products. Therefore, the initial investment cost is significantly lower than competitive systems. Crushing mill driving motors are direct current motors that need 12 V supply. Its energy can be easily supplied through batteries and PV panels. Product view is presented in Figure 1.



**Fig. 1.** Author concept and design of hazelnut unshelling apparatus

## RESULTS AND DISCUSSION

A crushing device with 300x150x500 mm dimensions and a unit weight of approximately 15kg has been developed. Two-stage operating speed is possible with this device. The maximum crushing capacity is about 20 kg/h. In addition, the rate of grain fragmentation, which is called product shredding, is around 10%. It presents quite acceptable values for such a compact and small apparatus.

## CONCLUSION

The simple and robust structures of these systems, their environmental friendliness (easy adaptation to renewable energy), low initial investment and operating costs offer significant advantages. It will be able to bring important alternatives to the expensive and large systems that dominate the sector. Due to competitive systems, final product prices may be more attractive to consumers. As a result, accessibility and more widespread consumption of hazelnuts, which are a means of qualified and healthy nutrition, will be ensured.

## REFERENCES

- [1] <https://arastirma.tarimorman.gov.tr/findik/Sayfalar/Detay.aspx?SayfaId=29>
- [2] <http://www.turktarim.gov.tr/Haber/103/en-saglikli-atistirmalik-findik>
- [3] [http://www.tadelle.com.tr/en/nutritional\\_values/default.aspx](http://www.tadelle.com.tr/en/nutritional_values/default.aspx)
- [4] Abdusselam M. S., Guney M. S., The Black Sea Journal of Sciences, 10(2), 493-500, 2020
- [5] Guner F., Guney M.S., Pneumatic Design Optimization in Hazelnut Shelling Process, Turkish Journal of Agriculture-Food Science and Technology, Volume 6 No 10, 2018

## DYNAMIC STABILITY OF A FLUID-IMMERSED PIPE CONVEYING FLUID AND RESTING ON A DAMPED WINKLER ELASTIC FOUNDATION

Dimitar Lolov<sup>1</sup>, Svetlana Lilkova-Markova<sup>2</sup>

<sup>1</sup>University of Architecture, Civil Engineering and Geodesy, Faculty of Hydraulic Engineering, Sofia, Bulgaria

<sup>2</sup>University of Architecture, Civil Engineering and Geodesy, Faculty of Hydraulic Engineering, Sofia, Bulgaria

e-mail: [dlolov@yahoo.com](mailto:dlolov@yahoo.com), [lilkovasvetlana@gmail.com](mailto:lilkovasvetlana@gmail.com)

**Abstract:** The dynamic stability of a pipeline resting on a damped Winkler elastic foundation and immersed in fluid that is moving with a particular velocity is investigated. The Galerkin method is employed to approach numerically the problem. Conclusions are drawn on the influence of the damped Winkler elastic foundation on the critical flow velocity of the pipeline.

**Key words:** stability, fluid, critical flow velocity, immersed pipe, damped Winkler elastic foundation

### INTRODUCTION

Pipes with flowing fluid and immersed in fluid are used in many areas of the industry. The flow of the fluid in the tube as well as the flow of the external fluid causes oscillations in it. A number of scientists are conducting research in the field of fluid-structure interaction.

Gregory and Païdoussis [4] were the first to present a solution to the equations describing the dynamics of the pipe. They define the velocity of the fluid at which the pipeline loses stability as the critical velocity of the fluid.

Deng and Yang [2] studied the dynamics of pipes with different types of flowing fluid. The tubes are immersed in fluid. The pipe is considered as a cylindrical shell. Numerical surveys have been performed. The fluid-filled tubes examined in [3] are buried in an elastic solid or immersed in fluid. A semi-analytic finite element method is applied. The results are compared with those obtained by the scaled boundary finite element method. Great coincidence of the results is observed.

In [5] is presented an investigation about the dynamic stability of a pipe with a flowing fluid immersed in a non-viscous fluid moving at a constant speed. It is also given an analytical solution for the same type of pipe with a rigid body attached at one of its ends.

Lin and Qiao [6] examined an axially moving pipe immersed in a fluid. The Differential quadrature method is applied. Pipes with three types of supports at both ends were studied: fixed-fixed, pinned-pinned, pinned + torsion spring - pinned + torsion spring. Parametric studies have been performed.

In study [7] is considered a moving tube immersed in fluid. An analytical solution for non-viscous and viscous fluid is presented. Brennan [1] presents research on the inertial forces with which a fluid acts on a body immersed in it. Examples of analytical research and experiments are presented.

Wu and Shin [8] performed a dynamic study of a continuous tube conducting fluid. Transfer matrix method is used. Lolov [9] investigates fluid conveying pipe immersed in moving fluid and lying on Winkler elastic foundation. Numerical studies have been performed to determine the critical velocities of the two fluids.

The present article examines the dynamics of a pipe lying on a damped Winkler elastic foundation. The dependence of the critical velocity of the fluid in the pipe on the critical velocity of the external fluid for different parameters of the of the damped Winkler elastic foundation is investigated.

### VIBRATION OF A FLUID-IMMERSED STRAIGHT PIPE CONVEYING FLUID

The transverse vibration of a fluid-immersed straight pipe conveying inviscid fluid and lying on a damped Winkler elastic foundation is governed by the following differential equation [5]:



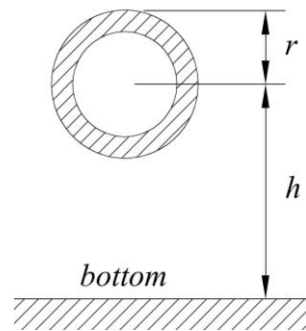
$$EI \frac{\partial^4 w}{\partial x^4} + (m_f V^2 + m_e V_e^2) \frac{\partial^2 w}{\partial x^2} + 2(m_f V + m_e V_e) \frac{\partial^2 w}{\partial x \partial t} + (m_f + m_p + m_e) \frac{\partial^2 w}{\partial t^2} + d_w \frac{\partial w}{\partial t} + k_w w = 0 \quad (1)$$

where  $t$  is the time,  $w(x, t)$  is the lateral displacement of the pipe axis,  $x$  is the coordinate along the axis,  $EI$  is the rigidity of the pipe. The mass of the pipe per unit length is denoted by  $m_p$  and the mass of the fluid per unit length of the pipe by  $m_f$ .  $m_e$  is the added mass of the external fluid.  $V$  is the flow velocity of the fluid in the pipe and  $V_e$  is the velocity of the external fluid.  $k_w$  and  $d_w$  are respectively the rigidity and the damping coefficient of the foundation.

The added mass of the external fluid per unit length of the pipe  $m_e$  in the case when the pipe is close to a horizontal plane (Fig.1) is calculated by the following formula, given in [1]:

$$m_e = \pi \rho_e r^2 \left( 1 + \frac{r^2}{2h^2} \right) \quad (2)$$

where  $\rho_e$  is the density of the external fluid.



**Fig. 1.** A scheme for obtaining the added mass of the external fluid

The spectral Galerkin method is applied to approximate the solution of differential equation (1). The solution is sought in the following form:

$$w(x, t) = \sum_{i=1}^n y_i(x) z_i(t) \quad (3)$$

where:

$z_i(t)$  - are unknown functions;

$y_i(x)$  - are basic functions that satisfy the boundary conditions of the pipe. Such functions are the functions describing the  $i$ -th mode of vibration of a beam with the same static scheme as the immersed pipe.

On the basis of the differential equation, describing the lateral vibrations of an immersed tubular beam, filled with stationary fluid ( $V = 0$ ) is obtained [8]:

$$y_i^{IV}(x) = \gamma_i^4 y_i(x) \quad (4)$$

where:

$$\gamma_i = \sqrt[4]{\frac{(m_f + m_p + m_e)\omega_i^2}{EI}} \quad (5)$$

where  $\omega_i$  is the circular frequency of the beam.

Substituting equation (3) into equation (1), one obtains the residual function:

$$R(x, t) = \sum_{i=1}^n \left\{ (m_f + m_p + m_e) y_i \ddot{z}_i + [d_w y_i + 2(m_f V + m_e V_e) y_i'] \dot{z}_i + [(EI\gamma^4 + k_w) y_i + (m_f V^2 + m_e V_e^2) y_i''] z_i \right\} \quad (6)$$

In (6) and in the sequel, primes denote derivatives with respect to  $x$  and dots with respect to the time  $t$ .

The Galerkin method requires the residual function  $R(x, t)$  to be orthogonal to the basic functions in the interval  $x \in [0; l]$ :

$$\int_0^l R(x, t) y_k(x) dx = 0, \text{ for } k = 1, \dots, n \quad (7)$$

Equation (7) is rewritten in the following form:

$$\sum_{i=1}^n \int_0^l \left\{ (m_f + m_p + m_e) y_i \ddot{z}_i + [d_w y_i + 2(m_f V + m_e V_e) y_i'] \dot{z}_i + [(EI\gamma^4 + k_w) y_i + (m_f V^2 + m_e V_e^2) y_i''] z_i \right\} y_k dx = 0 \text{ for } k = 1, \dots, n \quad (8)$$

Equation (8) represents a system of  $n$  differential equations with  $n$  unknown functions  $z_i(t)$ . In order to solve the system, the described in [8] method is applied. According to it the pipe is divided to sections with length  $\Delta x$ . The following relationships are taken into account:

$$\int_0^l y_i y_k dx = \{y_i\}^T \{y_k\} \Delta x \quad (9)$$

$$\int_0^l y_i' y_k dx = \{y_i'\}^T \{y_k\} \Delta x \quad (10)$$

$$\int_0^l y_i'' y_k dx = \frac{1}{EI} \{M_i\}^T \{y_k\} \Delta x \quad (11)$$

where in (9),(10) and (11):

$\{y_i\}$  - is a column vector consisting of the lateral displacements of the stations on the axis of the pipe, corresponding to the  $i$ -th eigen form in the case of stationary fluid ( $V = 0$ );

$\{y_i'\}$  - is a column vector consisting of the rotations of the cross-sections in the stations on the axis of the pipe, corresponding to the  $i$ -th eigen form in the case of stationary fluid ( $V = 0$ );

$\{M_i\}$  - is a column vector consisting of the bending moments in the stations on the axis of the pipe, corresponding to the  $i$ -th eigen form in the case of stationary fluid ( $V = 0$ ).  
Substituting (9),(10) and (11) in (8) the following system of  $n$  differential equations with  $n$  unknown functions  $z_i(t)$  is obtained:

$$\sum_{i=1}^n \left\{ (m_f + m_p + m_e) \{y_i\}^T \{y_k\} \ddot{z}_i + \left[ d_w \{y_i\}^T \{y_k\} + 2(m_f V + m_e V_e) \{y_i'\}^T \{y_k\}_i \right] \dot{z}_i + \left[ (EI\gamma^4 + k_w) \{y_i\}^T \{y_k\} + (m_f V^2 + m_e V_e^2) \frac{1}{EI} \{M_i\}^T \{y_k\} \right] z_i \right\} \Delta x = 0 \quad (12)$$

The system (12) could be rewritten in matrix form:

$$M \ddot{z} + C \dot{z} + K z = 0 \quad (13)$$

The general solution of the system (12) is expressed through the roots ( $\lambda_1, \dots, \lambda_{2n}$ ) of the equation:

$$\det X = 0 \quad (14)$$

The elements of the matrix  $X$  are given by:

$$X_{ik} = \lambda^2 M_{ik} + \lambda C_{ik} + K_{ik} \quad (15)$$

$$M_{ik} = (m_f + m_p + m_e) \{y_i\}^T \{y_k\} \Delta x, \quad M_{ik} = 0 \text{ (when } i \neq k) \quad (16)$$

$$C_{ik} = \left[ d_w \{y_i\}^T \{y_k\} + 2(m_f V + m_e V_e) \{y_i'\}^T \{y_k\}_i \right] \Delta x \quad (17)$$

$$K_{ik} = \left[ k_w \{y_i\}^T \{y_k\} + (m_f V^2 + m_e V_e^2) \frac{1}{EI} \{M_i\}^T \{y_k\} \right] \Delta x + E_{ik} \quad (18)$$

$$E_{ik} = EI\gamma^4 \Delta x, \quad E_{ik} = 0 \text{ (when } i \neq k) \quad (19)$$

On the basis of obtained roots ( $\lambda_1, \dots, \lambda_{2n}$ ) could be drawn conclusions about the stability of the system. The system is stable if the real part of all the roots of the characteristic equation (14) is negative.

The roots ( $\lambda_1, \dots, \lambda_{2n}$ ) depend on all the parameters of the system. If all of them are fixed except the velocity of the conveyed fluid  $V$  or the velocity of the external fluid  $V_e$ , one could obtain the corresponding critical velocities.

## RESULTS AND DISCUSSION

Numerical studies have been carried out for the fluid conveying pipe in Fig. 2.

The geometric and the material characteristics of the pipes are: rigidity  $EI = 771.26 \text{ kNm}^2$ ;  $m_p = 10.80 \text{ kg/m}$ ;  $m_e = 18.02 \text{ kg/m}$ . The density of the external fluid is  $\rho_e = 1 \text{ t/m}$  and the density of the internal fluid is  $\rho_f = 1.2 \text{ t/m}$ .

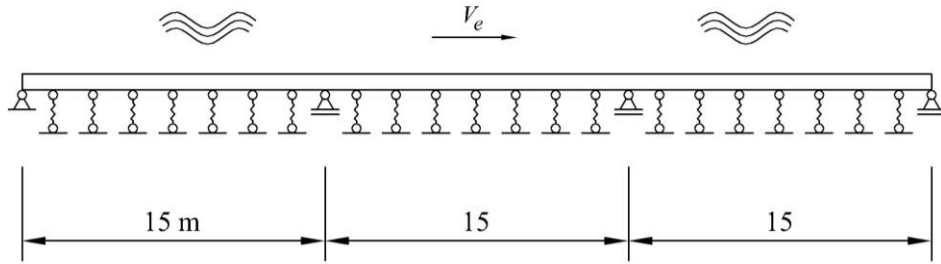


Fig. 2. Static scheme of the investigated pipe conveying fluid

In the Figures below is shown the dependence of the critical velocity of the fluid in the pipe  $V_{cr}$  on the critical velocity of the external fluid  $V_{e,cr}$  for different parameters of the of the damped Winkler elastic foundation. The sign ‘minus’ on the graphics corresponds to a velocity of the extremal fluid  $V_e$  that is in opposite direction of the velocity of the internal fluid  $V$ .

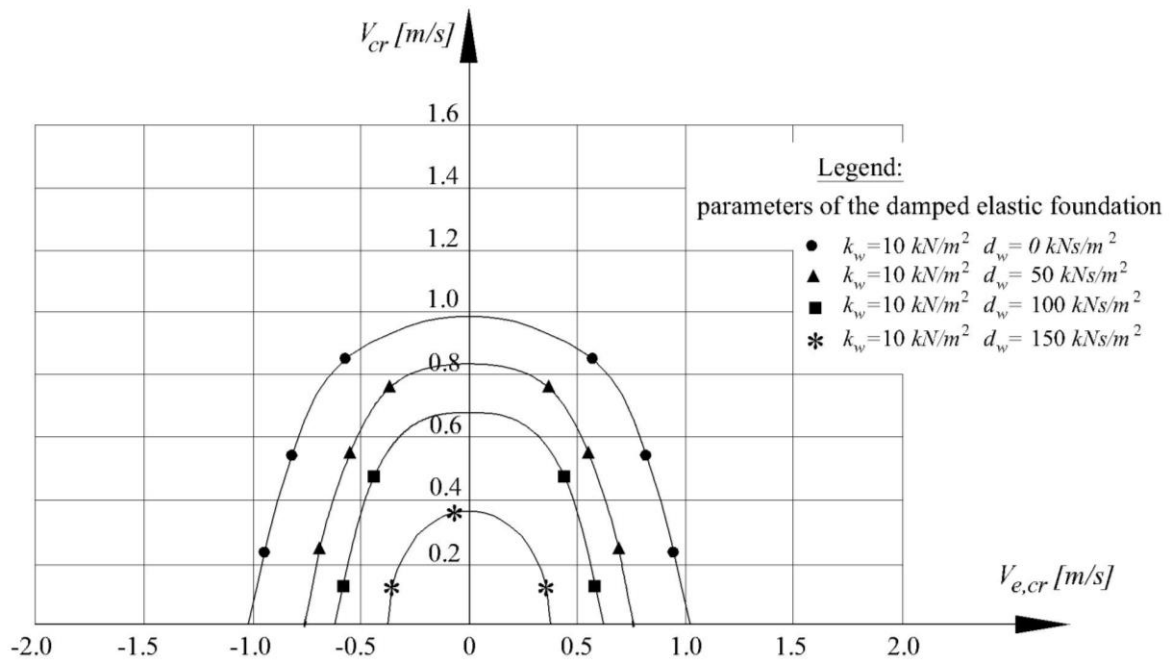
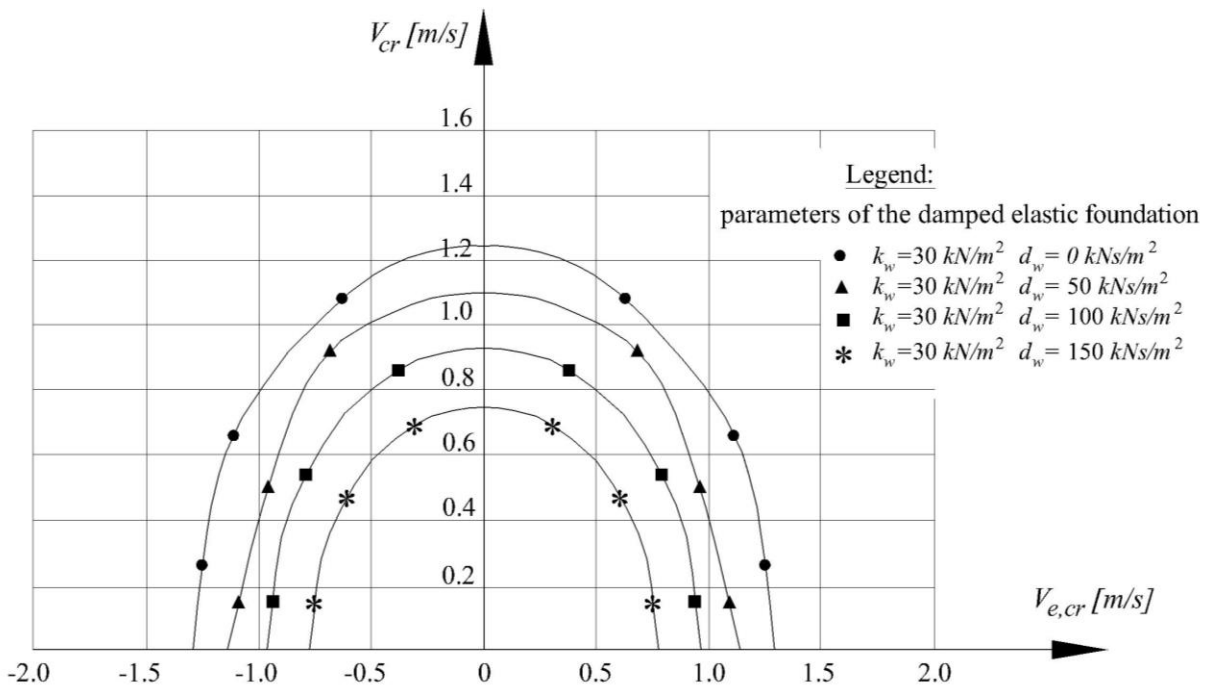
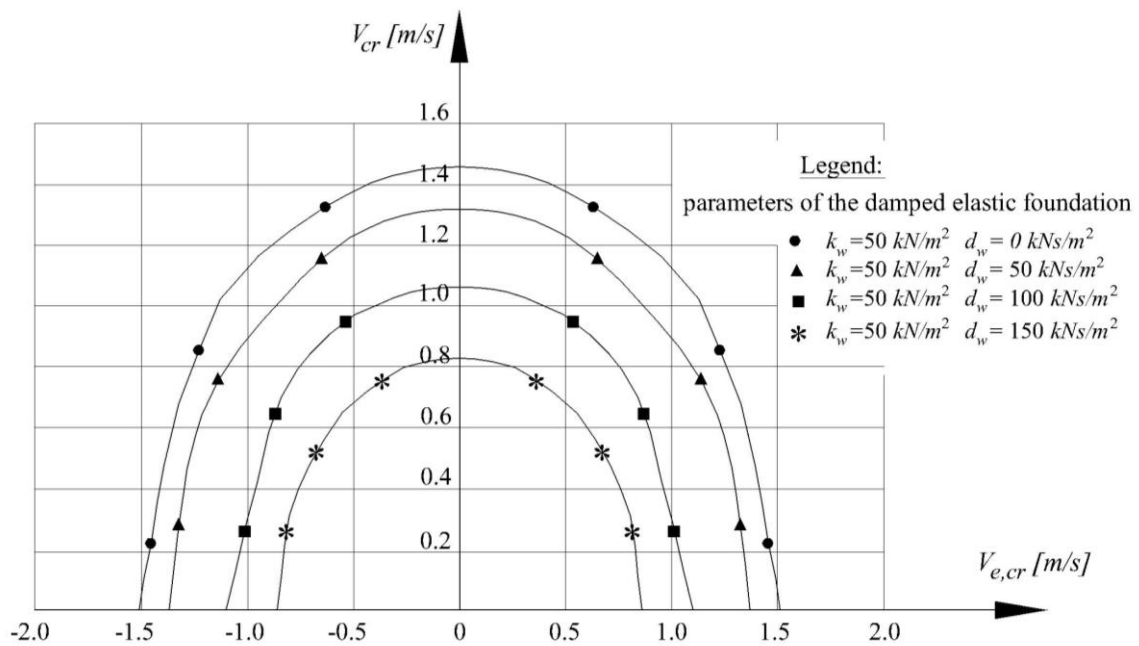


Fig. 3. Dependence of the critical velocity of the fluid in the pipe  $V_{cr}$  on the critical velocity of the external fluid  $V_{e,cr}$  for  $k_w = 10 \text{ kN} / \text{m}^2$



**Fig. 4.** Dependence of the critical velocity of the fluid in the pipe  $V_{cr}$  on the critical velocity of the external fluid  $V_{e,cr}$  for  $k_w = 30 \text{ kN} / \text{m}^2$



**Fig. 5.** Dependence of the critical velocity of the fluid in the pipe  $V_{cr}$  on the critical velocity of the external fluid  $V_{e,cr}$  for  $k_w = 50 \text{ kN} / \text{m}^2$

## CONCLUSION

The results in Fig.3, Fig.4 and Fig.5 show that for the investigated system the damping of the Winkler elastic foundation has a destabilizing effect. The bigger the damping parameter  $d_w$  the smaller is the stability area depicted in the Figures.

## REFERENCES

- [1] Brennan, C., A review of added mass and fluid internal forces, Technical Report, Naval Civil Engineering Laboratory, 1982.
- [2] Deng, Q., Yang Z., Wave propagation in Submerged Pipe Conveying Fluid, *Acta Mechanica Solida Sinica*, Vol. 32, No.4, pp. 483 – 498, 2019.
- [3] Duan, W., Kirby, R., Guided wave propagation in buried and immersed fluid-filled pipes: Application of the semi analytical finite element method, *Computers & Structures*, Vol. 212, pp. 236-247, 2019.
- [4] Gregory, R., Païdoussis, M., Unstable oscillations of tubular cantilevers conveying fluid, *Proceedings of the Royal Society of London*, Vol. A, pp.512-523 and pp.528-542, 1966.
- [5] Hellum, A., Mukherjee, R., Hull, A., Flutter instability of a fluid-conveying fluid-immersed pipe affixed to a rigid body, *Journal of Fluids and Structures*, Vol. 27 , pp. 1086-1096, 2011.
- [6] Lin, W., Qiao, N., Vibration and stability of an axially moving beam immersed in fluid, *International Journal of Solids and Structures*, Vol. 45, pp. 1445-1457, 2008.
- [7] Taleb, I., Misra, A., Dynamics of an axially moving beam submerged in a fluid, *Journal of hydronautics*, Vol. 15, Issue 1-4, pp. 62-66, 1981.
- [8] Wu, J., Shih, P., The dynamic analysis of a multispans fluid-conveying pipe subjected to external load, *Journal of Sound and Vibration*, Vol. 239, pp.201-215, 2001.
- [9] Лолов, Д., Динамична устойчивост на потопен тръбопровод, провеждащ флуид и лежащ върху Винклерова еластична основа (Dynamic stability of fluid-immersed pipe conveying fluid and lying on Winkler elastic foundation), XVI международна научна конференция ВСУ'2016, *Structural Mechanics, Structural Engineering, Earthquake Engineering*, pp. 85-90, 2016.

## ESTABLISHMENT OF WORKING UNITS IN THE MACHINE TOOLS OVERHAUL PRODUCTION SYSTEM

**Bogdan Marić<sup>1</sup>, Vlado Medaković<sup>1</sup>**

<sup>1</sup>University of East Sarajevo, Faculty of Mechanical Engineering East Sarajevo, East Sarajevo, Bosnia & Herzegovina

e-mail:[maricbogdan@ues.rs.ba](mailto:maricbogdan@ues.rs.ba), [vlado.medakovic@ues.rs.ba](mailto:vlado.medakovic@ues.rs.ba),

**Abstract:** The paper investigates the possibility of applying the concept of production on the principle of the so-called. group technology, i.e. the creation of work units (cells). This solution modifies the traditional layout according to the process, using all the advantages of line production. To make that possible, it is necessary to have a stable production program as one of the most influential factors in the choice of spatial structure. The following factors have been observed: the process of grouping parts of machine tools in the overhaul by applying the classification system and subject approach in the construction of production structures.

The first phase of empirical research has been related to the classification and categorisation of parts - production programs.

In the second phase, the analysis of classification and operational similarity of parts in the machine tools overhaul process has been performed.

The third phase has been related to the analysis of the representation of operational groups of individual machine tools in relation to the total number of formed operational groups in the machine tools overhaul production system.

Research has shown that there are certain laws in the formation of operational groups, which can reliably assess the impact of analysed factors on the formation of permanent work units in terms of equipment allocation and workplaces (layout) regardless of the introduction of different types of machine tools in the overhaul process, and that has enabled the overhaul process efficiency increase in the overhaul system.

**Key words:** group technology, work unit, overhaul, machine tool, layout

### INTRODUCTION

Today, the problem of increasing the efficiency of the machine tool overhaul process is given extraordinary attention. The reasons for that should be sought in the fact that machine tools form the basis of the production process in the metal industry. Their overhaul represents an unjustified cost for both users and manufacturers. Therefore, ways are being sought to reduce these costs, i.e. to increase the efficiency of the machine tools overhaul process.

In this regard, an efficient overhaul, especially its subsystem for the production of parts of machine tools which are in the process of overhaul, requires an appropriate choice of spatial structure. The selected spatial structure directly determines the material flow system, which is reflected in the controllability of production, production cycles and the degree of utilization of means of production[3].

The choice of spatial structure is influenced by a number of factors, the most influential of which are the *production program* and *technology*, i.e. the product assortment and quantities, degree of constructional and technological similarity of products, shape, dimensions and tolerances, rate of product changes, market life cycle etc.[3].

On the basis of the abovementioned, the main goal of restructuring the existing spatial layout, in our case that is the machine tools overhaul production system, has been to explore the possibility of applying the concept of production on the principle of so-called. group technology - creation of work units (cells). This solution attempts to modify the traditional layout according to the process, by using all the advantages of line production[8]. To make it possible, it is necessary to have a stable production program, as mentioned earlier, as one of the most influential factors in the choice of spatial structure.

The basic *hypothesis* in this paper is derived from the stated and reads:

*By applying the group technology, i.e. the classification system to the production program of the machine tools overhaul production system, it is possible to obtain a stable production program in the form of a finite number of operational groups.*

We will prove this hypothesis by the fact that the application of group technology, i.e. of the classification system on the production program of the machine tools overhaul production system, can lead to the formation of a finite number of operational groups regardless of the introduction of different types of machine tools in the overhaul process.

## GROUP TECHNOLOGY

In order to take advantage of batch production and, in some production systems, of individual production, the idea of group technology appeared in the sixties of the 20th century. Group technology is a concept according to which work objects with similar characteristics are grouped into families (groups). The approach is based on integrating the work objects with similar characteristics, on the basis of a classification system that contains the criteria of categorisation into the groups of work objects with similar technological characteristics. A group of work objects obtained in the mentioned way on a certain work operation is called an *operational group*. It takes place with a certain flow of the production system once or a few times in the observed time period as a function of the type of flow and forms the basis for designing the group flow of the work process. The goal is to facilitate the processes of design - construction, development of technological processes and design of production structures.

Grouping procedures enable visible reduction of technological work, organisation of material flows, easier control of data flows and bases, directing the work of technologists, constructors, planners and flow controllers to the operational group as the basic unit of the system, thus achieving significant output effects.

The basis for setting up of a grouping system is the system of classification, i.e. of the categorisation of the work objects of the program in question into groups, where this term implies a system which sets out the conditions of classification. The classification process basically consists of the division of the basic set into subsets according to certain characteristics and is essentially a decision-making process aimed at shaping the subsets according to the requirements of the technological process.

The implementation of group technology requires the construction of a system of classification of parts, on the basis of which the grouping into families is performed. The classification is performed according to the technological-constructive characteristics of the elements and with the help of the classification system, whereby the necessary information is obtained by linking individual codes or their combinations to the individual parameters of the elements. Which parameters of the elements will be taken into account in the classification and how the classification system will be developed depends on the constructive characteristics of the elements and on the type of technologies by which the elements are formed.

The classification can be performed even a step further by organising the equipment and workplaces in production according to the family of parts. In this case, all the necessary equipment is grouped to produce a certain family of parts, thus achieving a proper line flow. When a family of similar parts is produced in a work unit, some equipment (machine) can be duplicated from one work unit to another and the capacity utilisation can therefore be reduced more than with the alternative or mixed flow. Nevertheless, the overall benefits of group technology are significant, provided that the optimal number of parts can be covered in each work unit.

The practical application of group technology has two basic steps:

- identifying and defining the family of parts - *operational groups* and
- organisation of production equipment and jobs into appropriate *work units* (cells).

## WORK UNITS

Machines (classical or numerically controlled) are grouped in a work unit in accordance with the production process of a group of technologically similar work objects. The internal structure of a work unit (cell) is similar to the division on the basis of the type of processing, which has the flexibility of such a structure, but with a spatial arrangement which best suits the flow of production process materials for a defined product group. Due to that, the production system, consisting of work units, possesses the line efficiency and partially the flexibility of systems structured according to the type of processing. This structure also contributes to the humanisation of work, as it allows the workers an



insight into the entire production process, or the end result and purpose of their work. Therefore, the workers can perform a part of the organizational work, and that reflects in the increasing of motivation and achieving of better work results.

Structuring of a system into work units results in the division into smaller subsystems, and that significantly simplifies the material flow system, as well as the production planning and control. Therefore, they are particularly suitable for the application of the group technology concept and production automation.

Work units can be completely independent, implying that they can fully process a group of similar products from start to finish. Then there will be no flow of material among the work units in the system, but it will take place mostly only with the warehouses.

If for a given group of products and production quantities the load of some, especially expensive means of production is small, it is not profitable for economic reasons to provide such capacities, but they should, if possible, be shared with another work unit. Work units that share the means of production with other work units are called partially independent and cause a mutual flow of materials.

The basic characteristics of production in work units are[8]:

- shorter transport routes and less material handling than with layouts based on the process,
- shorter ordering time,
- reduced retention time of individual parts in the process by up to 80% compared to classic workshop production (smaller quantity of unfinished production),
- reduced amount of material in intermediate warehouses in relation to the schedule based on the processing process,
- better motivation of workers leads to increased productivity,
- simplified planning and production control,
- preparation time is reduced so that the batch replacement costs are lower (shorter preparatory-ending time).
- shorter waiting time of parts to be processed in relation to the production based on the processing process,
- reduced amount of scrap,
- better utilization of work surfaces leads to reduced investment costs for the building (up to 20%),
- more favourable use of equipment than in line production,
- relatively high productivity,
- large investments.

## METHODOLOGY

In this paper, the emphasis is placed on a research in terms of identifying and defining the family of parts - operational groups and the laws of formation of operational groups by introducing different types of machine tools into the overhaul process. For that purpose, the classification system KS-IIS-08 and the automated procedure for shaping production structures - APOPS-08 developed at the Institute for Industrial Systems of the Faculty of Technical Sciences in Novi Sad have been used to classify the replaced parts in the process of overhauling the following machine tools:

1. Radial drill „RABOMA“ 12U-1500,
2. Horizontal drilling and milling machine „TOS“ HB-80,
3. Short-run planer „PRVOMAJSKA“ KB-500,
4. Universal milling machine „PRVOMAJSKA“ UG-1,
5. Milling machine for hobbing „TOS“ FO-6,
6. Universal production lathe „POTISJE“ PA-30.

The replaced parts of these machine tools also make up the *production program* by the assortment ( $p_j$ ) and quantities ( $q_j$ ) of the machine tools overhaul production system.

The analysis of the production program consisting of the replaced parts of the mentioned machine tools will be performed using:

1. Coefficient of operational similarity and
2. Coefficient of representation of operational groups.

Ad. 1) The *coefficient of operational similarity* ( $K_{op.sl.}$ ) is a measure of unification of parts during the overhaul of machine tools according to predetermined characteristics and is given in the following form:

$$K_{op.sl.} = \frac{\text{number of operational groups}}{\text{number of different parts}} \cdot 100[\%]. \quad (1)$$

The size of the coefficient of operational similarity is influenced by predefined characteristics according to which the parts are grouped into certain operational groups. The coefficient of operational similarity directly affects the degree of flow seriality and the choice of the type of material flow in the machine tools overhaul production system by increasing the units of work objects with similar characteristics in the production program.

Ad. 2) The *coefficient of representation of operational groups* ( $K_{zog}$ ) is a measure of the representation of operational groups of a machine tool in overhaul in relation to the total number of formed operational groups in the machine tools overhaul production system and is given in the following form:

$$K_{zog} = \frac{\text{number of operational groups of a machine tool}}{\text{total number of operational groups}} \cdot 100[\%]. \quad (2)$$

## RESULTS AND DISCUSSION

In the text that follows, there is a presentation of the results of empirical research in terms of:

1. Analysis of production programs,
2. Analysis of operational similarity and
3. Analysis of the representation of operational groups.

Ad. 1) The production program is given in Table 1 in the form of assortment ( $p_j$ ) and total quantity ( $q_j$ ). The table shows a large number of different parts, and thus a large number of individual material flows through the machine tool overhaul production system.

**Table 1.** Replaced machine tool parts - Production program

Ord no.	NAME OF THE MACHINE TOOL	Production program	
		Assortment ( $p_j$ ) [pcs]	Quantity ( $q_j$ ) [pcs]
1	Radial drill „RABOMA“ 12U-1500	189	615
2	Horizontal drilling and milling machine „TOS“ HB-80	125	477
3	Short-run planer „PRVOMAJSKA“ KB-500	145	261
4	Universal milling machine „PRVOMAJSKA“ UG-1	80	212
5	Milling machine for hobbing „TOS“ FO-6	92	121
6	Universal-production lathe „POTISJE“ PA-30	109	139

Ad. 2) Coefficients of operational similarity for individual machine tools in overhaul are given in Table 2. Through the coefficients of operational similarity, the table shows how much the number of material flows in the production system will be reduced by forming operational groups in relation to individual flows. That percentage of overhaul of one machine tool ranges from 75% to 85,2%. However, by increasing the number of machine tools that are in the process of overhaul, the number of material flows in the production system decreases by 94,3%.

Ad. 3) By applying the classification system KS-IIS-08 and the automated procedure for shaping production structures - APOPS-08 to the parts, i.e. the production program for the mentioned machine tools, a total of 42 operational groups has been formed.

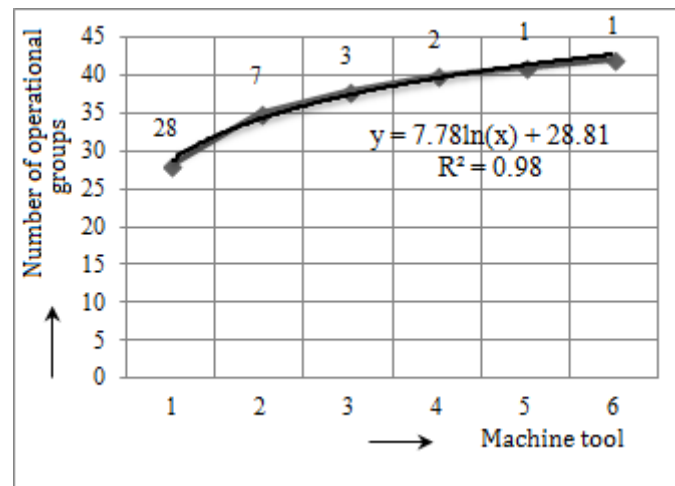
The representation of the operational groups of individual machine tools in the total number of operational groups is given, through the coefficient of representation of operational groups ( $K_{zog}$ ), in Table 2.

**Table 2.** Values of coefficients of similarity and coefficients of representation of operational groups

Ord. no.	NAME OF THE MACHINE TOOL	Number op. group	$K_{op.sl.}$ [%]	$K_{zog}$ [%]
1	Radial drill „RABOMA“ 12U-1500	28	85,2	66,6
2	Horizontal drilling and milling machine „TOS“ HB-80	27	78,4	64,3
3	Short-run planer „PRVOMAJSKA“ KB-500	24	83,4	57,1
4	Universal milling machine „PRVOMAJSKA“ UG-1	19	76,3	45,2
5	Milling machine for hobbing „TOS“ FO-6	23	75	54,8
6	Universal-production lathe „POTISJE“ PA-30	33	79,8	52,4

Analysis of the representation of operational groups indicates that the representation of operational groups of individual machine tools in the total number of formed operational groups ranges from 45,2 to 66,6%, which indicates a certain consistency of the formed operational groups.

The increase of newly formed operational groups of individual machine tools in relation to the number of formed operational groups of radial drill „RABOMA“ 12U-1500 is shown in Figure 1.



**Fig. 1.** Diagram of growth of operational groups

The representation of parts in newly formed operational groups is:

- 12% on the horizontal drilling and milling machine „TOS“ HB-80,
- 2,8% on the short-run planer „PRVOMAJSKA“ KB-500,
- 3,8% on the universal milling machine „PRVOMAJSKA“ UG-1,
- 1,1% on the milling machine for hobbing „TOS“ FO-6,
- 14,7% on the universal-production lathe „POTISJE“ PA-30.

From the diagram in Figure 1, we notice the regularity of the growth of operational groups. This regularity leads to the conclusion that there is no significant increase in operational groups, clearly indicating that the established work units in the machine tools overhaul production system based on group technology will not change regardless of the introduction of different types of machine tools in the overhaul process.

On the basis of the mentioned, it can be concluded that the hypothesis of the subject paper has been proven.

## CONCLUSION

The research presented in this paper and the obtained results lead to the following conclusions:

- The presented grouping procedure and the applied classification system are an objective basis for:
  - development of a flexible machine tools overhaul production system with an increased degree of efficiency based on work units;
  - defining of the scope and structure of overhaul works for certain types and families of machine tools;
  - constructive unification of parts in the process of deffectation;
  - unification of surfaces of parts, materials and semi-finished products.
- The developed grouping procedure and the applied classification system are applicable in real machine tools overhaul production systems with the:
  - definition of the machine tools overhaul corpus,
  - definition of the overhaul for certain types and families of machine tools,
  - definition of production and material norms,
  - introduction of a classification-identification system,
  - introduction of an appropriate information system based on computer data processing,
  - introduction of the necessary technological discipline.
- Overhaul of capital equipment, such as machine tools, performed in the presented manner, will provide better efficiency in comparison to the previous method of execution.

## REFERENCES

- [1] György Kovács, Sebastian Kot, Facility layout redesign for efficiency improvement and cost reduction. *Journal of Applied Mathematics and Computational Mechanics* 2017, 16(1), 63-74  
[https://www.researchgate.net/publication/221511773\\_Design\\_of\\_Product\\_Oriented\\_Manufacturing\\_Systems](https://www.researchgate.net/publication/221511773_Design_of_Product_Oriented_Manufacturing_Systems)
- [2] Jurković M., Reinženjering proizvodnih poduzeća, Razvoj i modernizacija proizvodnje, Univerzitet u Bihaću, Bihać 2011.
- [3] Kunica Z., Projektiranje proizvodnih sustava. Fakultet strojarstva i brodogradnje Sveučilišta u Zagrebu, 2016. (<http://titan.fsb.hr/~zkunica/nastava/pps.pdf>)
- [4] Richard Muther and Lee Hales, *Systematic Layout Planning*. Management & Industrial Research Publications, USA, 2015.
- [5] Shubham Barnwal, Prasad Dharmadhikari, Optimization of Plant Layout Using SLP Method. *International Journal of Innovative Research in Science, Engineering and Technology*, Vol. 5, Issue 3, March 2016.
- [6] Sílvio do Carmo-Silva, Anabela Carvalho Alves, Detailed Design of Product Oriented Manufacturing Systems. Fifth IFIP/IEEE International Conference on Information Technology for Balanced Automation Systems in Manufacturing and Services (BASYS'02), September 25-27, 2002, Cancun, Mexico.
- [7] Zelenović D., Projektovanje proizvodnih sistema. Fakultet tehničkih nauka u Novom Sadu, 2009.
- [8] Zrnić Đ., *Fabrička postrojenja, I deo – projektovanje fabrika*. Mašinski fakultet Univerziteta u Beogradu, 1990.

## ESTABLISHING PULL SYSTEM IN ORDER MANUFACTURING – CASE STUDY

**Bogdan Marić<sup>1</sup>, Vlado Medaković<sup>1</sup>**

<sup>1</sup>University of East Sarajevo, Faculty of Mechanical Engineering East Sarajevo, East  
Sarajevo, Bosnia & Herzegovina

e-mail:[maricbogdan@ues.rs.ba](mailto:maricbogdan@ues.rs.ba), [vlado.medakovic@ues.rs.ba](mailto:vlado.medakovic@ues.rs.ba),

**Abstract:** This paper describes the application of the CONWIP system in a production system, based on withdrawal. The practical advantages of CONWIP over push and other pull systems are given. Theoretical arguments are presented in favor of the CONWIP system in manufacturing companies whose production is based on production "to order". The CONWIP system is fully implemented in a real company, whose implementation process is described in detail and presented in the paper. Simulation studies are included to gain insight into system performance.

**Key words:** CONWIP, pull system case study, pull system implementation, modeling and simulation

### INTRODUCTION

In today's business environment, organizations are forced to continuously analyze all aspects of their work, in order to improve competitiveness and ensure business continuity, and to react quickly to any changes, either external or internal. Among the many methods for improving a company's business is the Lean concept, which is the most comprehensive and powerful concept for achieving business excellence [11]. Its great advantage is that it equally strongly promotes companies that are in crisis, then those that are doing well but want to achieve growth, and companies that are doing great business but their constant goal is to improve quality in all areas.

According to [4,22] technological advances have made it possible to increase product diversity and shorten product life cycles, while on the other hand increasing customer demands in terms of delivery times, prices and product quality, which led production organizations to seek changes in their production environment with the goal of better performance.

Each production organization [3,22] has its own specifics, which does not make this choice trivial. The competitive advantage [1] of custom manufacturing companies largely depends on their ability to provide short deadlines and on-time delivery. This requires efficient production which we can provide by applying the Lean concept. Why Lean Concept?

- (1) Because Lean concept methods are process-based and therefore universal and applicable in almost all industries and business segments;
- (2) Because the Lean concept is a systematic approach to identifying and disposing of waste (activities without adding value) through continuous improvement in the pursuit of perfection.

In addition to the automotive industry in which the Lean concept has achieved significant success, there are a number of papers in the professional and scientific literature that present case studies of the Lean concept in other manufacturing, service and, more recently, public service organizations, and the results are challenging.

However, it should be emphasized that many of these works are descriptive in nature and do not give concrete results in the application of the Lean concept. Therefore, more empirical research is lacking to examine the applicability of the principles, methods, and tools of the Lean concept in the above organizational systems. Therefore, this paper focuses on empirical research on the establishment of the PULL system, as one of the five principles of the Lean concept[17], using the CONWIP system to establish the flow of materials in the production of panel furniture in a company whose production strategy is "custom" production.

In the original interpretation, the PULL system is a decentralized establishment of material flow in production through the KANBAN system, which is aligned with customer demand. Production begins as soon as demand arises, and the flow of material between work centers is established using KANBAN cards, where production in one work center begins when demand arises in the next work center. This traction system is not applicable to custom production for two reasons:

- (1) Production systems of this type use a custom production strategy, where it makes no sense to produce before the customer's need arises, since it is not possible to predict what the customer will need;
- (2) Due to the large number of different types of products in this type of production, it is not possible to keep interoperable stocks in supermarkets in the way that is done in traditional Lean production systems.

With this in mind [19] they define the PULL system, as any system that limits the level of work in progress. This definition starts from the role that KANBAN plays in traditional Lean production but generalizes the definition by not explicitly mentioning KANBAN and suggesting that the PULL system can be realized by other means as well. Accordingly [20], they propose a CONWIP (Constant Work In Process) system for the establishment of PULL systems in non-traditional Lean production systems, such as e.g. production systems whose production strategy is production "to order" as an alternative to the KANBAN system.

In[1], a discrete simulation was applied to study the delivery performance of a custom production system that is configured as a general flow, when used under two mechanisms to control the flow of materials based on CONWIP and GKS cards.

In[30], a comparative analysis of the production environment is given, through the assessment of the approach to the scheduling of withdrawn, suppressed and hybrid production in different scenarios, through computer simulation. The study was conducted in a real company which led to the construction of a conceptual model that represented a real production environment. A computer model was generated through the conceptual model, using simulation software.

Some authors, such as [3,22] suggest comparative experimental studies, pointing to differences in production systems in certain environments. According to [22], choosing the best approach is a complex process because it requires an urgent response to a market that has a changing character. It emphasizes [22] that flexible systems that can combine the best of each approach at different stages and times of production tend to be better than systems with fixed and individual production schedules. The application of Lean production [14] with schedule withdrawal does not guarantee the same results for manufacturing companies, although they are similar, which makes the choice of production schedule even more complex.

Paper [7] presents a method that uses control panels to determine the most appropriate array for the application of a set of Lean tools. Control panels are usually used to identify out-of-control points and determine the underlying causes from the appropriate process. This paper [7] presents a new function of control charts, which is to determine the best sequence for the application of a set of Lean tools.

In [6], the CONWIP system received much attention from researchers after proposing MRP and KANBAN, and comparing the performance of MRP, KANBAN on the one hand and CONWIP on the other, where the simulation results confirmed the effectiveness of this model.

The paper [8] describes four models of CONWIP systems that have been used to date, namely: basic CONWIP system, hybrid CONWIP system, multi-product CONWIP system and parallel CONWIP system.

The most common form [9] of production control strategy in lean management is the pull system. One of the new forms of pull systems uses KANBAN and CONWIP systems to handle products with different demand patterns. Case studies have long shown the actual application of PULL systems, however the use of hybrid systems is rare. The paper [9] shows the procedures and application of a hybrid system, and how the simplicity of the PULL system can reduce in-service inventories by 23%.

This paper [24] presents a simulation study of different scenarios that vary the number of segments, the WIP level of each segment and their combinations. They showed that line segmentation using different CONWIP levels affects line performance. In some cases, compared to a single segment CONWIP and a Push system, using a segmented CONWIP system can achieve the same flow rate in a shorter cycle time.

## **CONWIP SYSTEM**

The CONWIP (Constant Work In Process) system was introduced [18] as an attempt to present a more flexible withdrawal system than the Kanban system. It is a PULL system because it restricts WIP (Work In Process) via kanban-like cards. The difference is that Kanban cards are tied to a certain part

and control the movement of materials in only one stage of production (in the next phase another card is tied to a certain part), while cards in CONWIP are assigned to a part (task) at the beginning of the system and follow it throughout the entire processing process. When the CONWIP card returns to the beginning of the system, it only has information to produce any job that follows in the queue. No job can enter the system without a proper card, which means that starting a new job is only possible when some of the jobs leave the production process, thus keeping the number of jobs that are constantly in production constant.

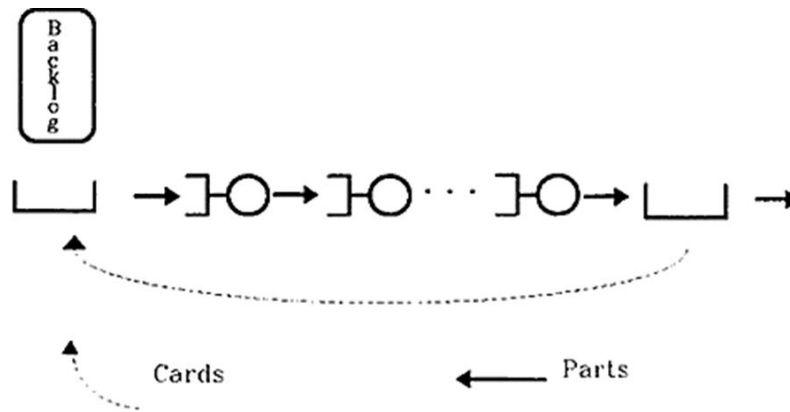


Fig. 1. CONWIP scheme[20]

The CONWIP system can also be classified as a hybrid between a pure PUSH system and a pure PULL system[15,21,23], which within operational planning provides the scheduling of operations - work tasks by jobs in accordance with the obligations of the production system to customers, taking into account resource constraints, with forward or backward planning starting from the point of separation. In the structure of custom production, the most common case is that the assembly is the point of separation because it delivers the final products to the customers (buyers).

The authors[13,16] proposed a method to evaluate the performance of a CONWIP system for multiple products processed on the same production line. Implemented a CONWIP system[5] in an agricultural machine industry, observing a reduction of the material in process and an increase in productivity. Implemented[10] the CONWIP system in a factory of electro-mechanical components, reducing cycle time and increasing production volume. Have[2] used the CONWIP system principle to synchronize demand and supply in manufacturing leading to the formation of sustainable supply chains in on-demand project companies.

## IMPLEMENTATION OF PULL SYSTEM IN THE RESEARCHED PRODUCTION SYSTEM

Empirical research on the establishment of the PULL system was performed in the sector for machine processing of sheet material, which is a subsystem of the production organization for the production of furniture that is produced exclusively according to customer requirements. The basic business philosophy of the company is based on the production strategy of production "to order" where the entire range of products is made at the request of the customer. Most products are individual, unique pieces of furniture that are made once and never repeated. Combining innovative technology, staff expertise and distinctive style, the Inside team creates a unique solution for the needs of its customers. Customers are sophisticated people who recognize and value design and quality, which is why the quality of the offer and service provided by the Inside brand is determined by the customer.

In order to implement the PULL system using CONWIP in the researched production system, the following were first designed and made: (1) Map (form) "Production plan", (2) Conwip board, (3) Conwip card and (4) Universal trolley for transport, whose general design information is described below.

## Map "Production plan"

The production plan (activity) is a response to the uncontrolled release of an order (work order). Based on the demand and agreed delivery deadlines, as well as the planned delivery of raw materials by the supplier, and the amount of work for each order (work order) and the norm for each operation, a production plan is made in the form of a Gantt chart (Fig. 3). do not overload jobs.

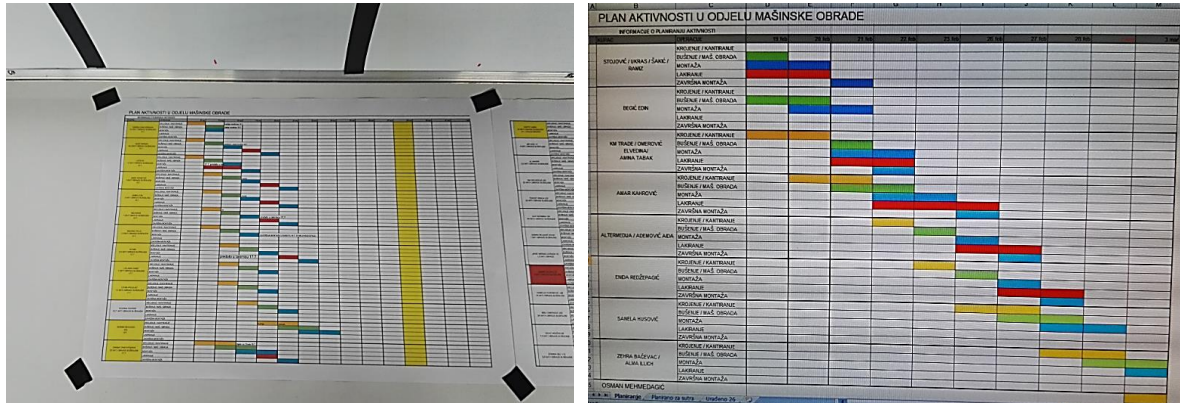


Fig. 3. Plan of activities in the machining sector on the CONWIP board

Since it is difficult or impossible to accurately predict the time of production (production) for individual operations in production "to order", average production times are taken, which, in the final analysis, more or less coincide with the production (production) plan.

New work orders are not put into production as soon as they are ready, but are retained in a pool of jobs, and put into production based on feedback on production load or spare capacity.

The activity plan / standardization is harmonized with the capacity of the CNC machining center VENTURE 1M, CNC dowel ABD 260 and CNC dowel BHX because they represent bottlenecks in production. The "Production Plan" map is located on the front of the CONWIP panel, as shown in Figure 6.

## CONWIP board

The CONWIP dashboard is a workshop job management tool, designed to visually represent the current state of the production process, limit ongoing work (WIP) and maximize efficiency and throughput. In addition to presenting planned (planned) and current activities (Map of the production plan located on the CONWIP panel, Fig. 6), this tool provides information on downtime as well as other information related to the production process. By reviewing this tool, the manager is continuously informed about the state of the production process, whether there is an overload of certain jobs, whether they are late or in a hurry with the delivery of products, etc.

## CONWIP card

The design of the CONWIP card, with the entered data about the order / product, is shown in Figure 4.

## Universal transport trolley

The design of universal trolleys, with basic dimensions, is shown in Figure 5. The construction of the new trolley model took into account the observed shortcomings in the existing transport of elements.



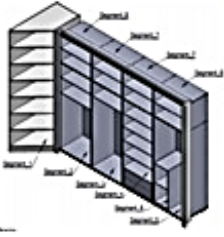
Amra Katić		Poz:	2	
Closet		Kom.:	105	Verificatio
	lTail (m)	101	48 min.	
	Kant.(m)	101	48 min.	
	ABD	58	116 min.	
	BHX	37	177.6 min.	
	VENT.	10	48 min.	
	MONT.	105	525 min.	
lParticleboard material	LAK.			min.
TP: Bužo	Z.MONT.			min.
No. of trolles 1- 2- 3- 4- 5- 6- 7- 8- 9- 10- 11- 12- 13- 14- 15- 16				
			Lead Time	24 h

Fig. 4. CONWIP card



Fig. 5. Universal transport trolley

## VERBAL DESCRIPTION OF THE IMPLEMENTED PULL SYSTEM

### Description of operation on the CONWIP board

When new orders are launched, according to the production plan, the new card is magnetically pasted on the CONWIP board in the "to do" section. Orders are tailored to the plan and the cart released. When the order is cut, the card is moved to the "completed" section on the CONWIP panel. On the CONWIP card, the operator enters the name and date when the job was completed. In the next operation, when the operator completes the processing of the current (current) order, he also moves the CONWIP card of the processed order to the "completed" field, postpones the work order to the designated place on the CONWIP board, so that it is available for subsequent operations. "is required to pick up the next CONWIP card which is in order, as well as the work order. The empty space from which he withdrew the CONWIP card on the CONWIP board should be filled by moving the other CONWIP cards upwards, as shown by the arrows in Figure 6. This ensures that the order of order processing by FIFO method "first entered, first exited" is not disturbed. This means that the work order whose positions were first cut should also be the first to leave production.

If a problem occurs during the processing process, a sticker (sticker) with a description of the problem (damaged part, drilling error, undefined drawing, etc.) is pasted on the CONWIP card to make it easier to spot and resolve in a timely manner. The CONWIP card is not pushed any further, but is retained in that job until the problem is resolved and the next order is taken for processing.

If for some reason there is a stoppage in production, e.g. when drilling, the next operation (assembly) consumes the stock from the buffer (4 trolleys in the intermediate warehouse), the most it can release is 4 trolleys and still new orders cannot be cut until the production delay is eliminated. Therefore, it cannot be tailored uncontrollably. It should be emphasized that there can be several orders (smaller) or one order on several carts on one cart.

The work order, if the processing is performed on a certain machine, must also be at that workplace. When processing is complete, the order will be returned to the shelf on the CONWIP board. According to this rule, we can always know where the work order is - just look at the location of the CONWIP card on the CONWIP board.



Fig. 6. Scheme of work on the CONWIP board

### Description of the establishment of the PULL system

According to the traction system, we will observe the production process from the end. Thus, when the product is assembled (assembled) in the last stage of production (assembly), then the carts on which the parts have gone through the production process are made. The released carts are a signal that they need to be filled at the beginning of the production process, but then the assembly capacity is also released, so the worker withdraws a new job from the previous operation (drilling). In the previous operation (drilling) it is necessary to always have prepared pieces for assembly. The amount of work prepared depends on the complexity of the product, as well as the total number of carts in the production process. By reducing or increasing the number of carts, the quantity of pieces between operations, ie the quantity of unfinished production, decreases or increases. It is normal to strive to keep the number of carts as small as possible, which depends on the efficiency of the production process and the product mix. When the trolley with the new product is withdrawn for assembly, the capacity of the intermediate storage on the drilling operation is released. This is a signal that it is necessary to approach the drilling operation at the positions from the new order in order to fill the intermediate storage. Under the same system, the withdrawal of a new job on the operations "edging" and "tailoring" works.

The number and size of transport trolleys establish the flow of material according to the PULL system as shown in Figure 7. The trolleys are intermediate warehouses and serve as "buffers" which regulate the current deviations in production times in individual operations compared to the planned times.

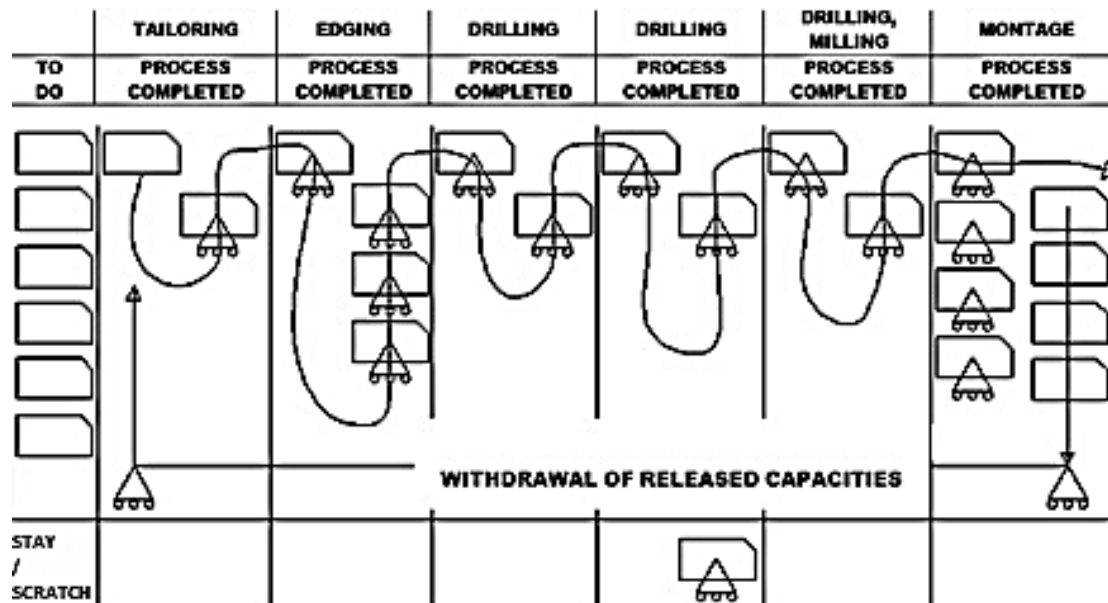


Fig. 7. Material flow according to the PULL system in the machining sector

## CONCLUSIONS

Based on theoretical knowledge, conducted research and their analysis, and practical experience, the following conclusions can be drawn:

- In the researched production system, a PULL system was established using the CONWIP system;
- Taking into account the fact that traditional Lean production systems produce products only when there is direct customer demand. If viewed in this way, it can be concluded that production systems that produce at the request of the customer always produce according to the traction system, because they use the strategy of production "to order";
- The establishment of the PULL system established regularity in production;
- The establishment of the PULL system shortened the production cycle from 10,59 days to 6,52 days, or 38,4%.

## REFERENCES

- [1] C. Gomes, A. Ribeiro, J. Freitas, L. Dias, G. Pereira, A. Vieira, N. O. Fernandes, S. Carmo-Silva, "Improving Production Logistics Through Materials Flow Control and Lot Splitting", Springer International Publishing Switzerland 2016 A. Pias et al. (Eds.): ICCL 2016, LNCS 9855, 2016. pp. 443–453
- [2] P. Dallasega, E. Rauch, "Sustainable Construction Supply Chains through Synchronized Production Planning and Control in Engineer-to-Order Enterprises", Sustainability, vol. 9, no. 10, 2017, doi: 10.3390/su9101888.
- [3] Q. Gong, Y. Yang, S. Wang, "Information and decision-making delays in MRP, KANBAN, and CONWIP", International Journal of Production Economics, vol. 156, pp. 208-213, 2014, doi: 10.1016/j.ijpe.2014.06.010.
- [4] H. Güçdemir, H. Selim, "Customer centric production planning and control in job shops: A simulation optimization approach", Journal of Manufacturing Systems, vol. 43, pp. 100-116, 2017, doi: 10.1016/j.jmsy.2017.02.004.
- [5] A. Hoose, L. A. Consalter, O. M. Durán, "Implementación de un Sistema Híbrido Tipo Trabajo Constante en Progreso (CONWIP) para Control de Producción en una Industria de Implementos Agrícolas", Información Tecnológica, vol. 27, no. 2, pp. 111-120, 2016, doi: 10.4067/S0718-07642016000200014.
- [6] J. Kang, "Modeling and Simulation of CONWIP Systems for Low-volume But More-varieties Products", Management & Engineering, 01, pp. 1838-5745, 2010.

- [7] J. Prakash, L. B. Kiat, J. F. Chin, Y. C. Choong, "Determination of Sequence for Implementation of Lean Tools using Discrete Event Simulation", *Aust. J. Basic & Appl. Sci.*, 9(32), pp. 155-165, 2015.
- [8] J. Prakash, J. F. Chin, "Variation of CONWIP Systems", *World Academy of Science, Engineering and Technology International Journal of Mechanical and Mechatronics Engineering*, vol:6, no:12, 2012.
- [9] J. Prakash, J. F. Chin, "Implementation of hybrid parallel kanban-CONWIP system: A case study", *Cogent Engineering*, 1, <http://dx.doi.org/10.1080/23311916.2014.938922>, 2014.
- [10] D.G. Leonardo, B. Sereno, D.S.A.D. Silva, "Implementation of hybrid Kanban-CONWIP system: a case study", *Journal of Manufacturing Technology Management*, vol. 28, no. 6, pp. 714-736, 2017, doi: 10.1108/JMTM-03-2016-0043.
- [11] X. Li, Z. Li, G. Wu, "Lean precast production system based on the CONWIP method", *KSCE Journal of Civil Engineering*, pp. 1-11, 2017. doi: 10.1007/s12205-017-2009-4.
- [12] N.M.G. Pinheiro, M.G. Cleto, I.C. Zattar, S. Isoldi and M.G. Muller, "Performance evaluation of pulled, pushed and hybrid production through simulation: a case study", *Brazilian Journal of Operations & Production Management*, 16, pp 685-697, 2019. doi: 10.14488/BJOPM.2019.v16.n4.a13
- [13] C.W. Park, H.S. Lee, "Performance evaluation of a multi-product CONWIP assembly system with correlated external demands", *International Journal of Production Economics*, vol. 144, no. 1, pp. 334-344, 2013. doi: 10.1016/j.ijpe.2013.02.021.
- [14] C.M. Pereira, R. Anholon, A. Batocchio, "Obstacles and difficulties implementing the lean philosophy in Brazilian enterprises", *Brazilian Journal of Operations & Production Management*, vol. 14, no. 2, pp. 218-227, 2017. doi:10.14488/BJOPM.2017.v14.n2.a10.
- [15] J. Prakash, J.F. Chin, "Modified CONWIP systems: a review and classification", *Production Planning & Control*, vol. 26, no. 4, pp. 296-307, 2015.
- [16] J. Reschke, G. Schuh, "Scheduling parameters in Production Planning and Control", *Systemics, Cybernetics and Informatic*, vol. 15, no. 1, pp. 62-66, 2017.
- [17] S. Sarbjit, "Study on Push/Pull Strategy Decision Taken by Organizations for Their Products and Services". *Universal Journal of Management*, 5(10), pp. 492-495, 2017.
- [18] M. Spearman, D. Woodruff, W. Hopp, "CONWIP: a PULL alternative to kanban", *International Journal of Production Research*, 28, pp. 879-894, 1990.
- [19] D.J. Stockton, R.J. Lindley, "Implementing kanbans within high variety/low volume manufacturing environments", *International Journal of operations & production management*, 15(7), pp. 47-59, 1995.
- [20] B. Stump, F. Badurdeen, "Integrating lean and other strategies for mass customization manufacturing: a case study", *Journal of Intelligent manufacturing*, 23(1), pp. 109-124, 2012.
- [21] M. Thürer, M. Stevenson, C.W. Protzman, "Card-based Control Systems for a Lean Work Design: The Fundamentals of Kanban, ConWIP, POLCA and COBACABANA", *Productivity Press*, 2016. ISBN 978-1498746946.
- [22] C. Wolfsgruber, G. Lichtenegger, "Optimal Configuration in Production Planning and Control", *BHM Berg-und Hüttenmännische Monatshefte*, vol. 161, no. 5, pp. 221-224, 2016. doi: 10.1007/s00501-016-0474-6.
- [23] J. Womack, D. Jones, "Lean Thinking: Banish waste and create wealth in your corporation", *Simon & Schuster*, New York, USA, 1996.
- [24] M. Yassin, I.A.E.K. Shaalan, S.E.K. Khaled, "Simulation Analysis of Segmented CONWIP: Application to Reentrant Flow Lines", *Proceedings of the International Conference on Industrial Engineering and Operations Management*, Bandung, Indonesia, 2018.
- [25] N. Sremčev, B. Stevanov, M. Lazarević, J. Mandić, Z. Tešić, and B. Kuzmanović, "Improving Process of Quotation Creation Through Value Stream Mapping and Simulation", *International Journal of Simulation Modelling*, vol. 18, no 4, pp. 563-573, 2019, doi.org/10.2507/IJSIMM18(4)484

## THE INFLUENCE OF CARBON FIBER ORIENTATION ANGLE ON BUCKLING PROPERTIES OF FOUR-LAYER SYMMETRIC LAMINATE UNDER BIAXIAL COMPRESSION

Dejan Jeremić<sup>1</sup>, Nebojša Radić<sup>1</sup>, Nikola Vučetić<sup>1</sup>

<sup>1</sup>University of East Sarajevo, Faculty of Mechanical Engineering East Sarajevo  
e-mail: [dejan.jeremic@ues.rs.ba](mailto:dejan.jeremic@ues.rs.ba)

**Abstract:** The present work focused on the buckling of four-layer symmetric laminate subjected to biaxial compression. Governing equations are derived based on Classical Laminated Plate Theory (CLPT). The composite plates are bonded by an internal elastic medium and surrounded by external elastic foundation. The influences of carbon fiber orientation angle and aspect ratio on critical buckling load are demonstrated for symmetric laminate. We analyzed four lamination scheme which fiber angle orientation is equal to 0°, 30°, 45° and 90°.

**Key words:** analytical modelling, buckling, composite plates, carbon fiber angle

### INTRODUCTION

A composite material is composed of reinforcement (fibres, particles, flakes, and/or fillers) embedded in a matrix (polymers, metals, or ceramics). The matrix holds the reinforcement to form the desired shape while the reinforcement improves the overall mechanical properties of the matrix. A laminate is called symmetric if the material angle, and the thickness of plies are the same above and below the midplane.

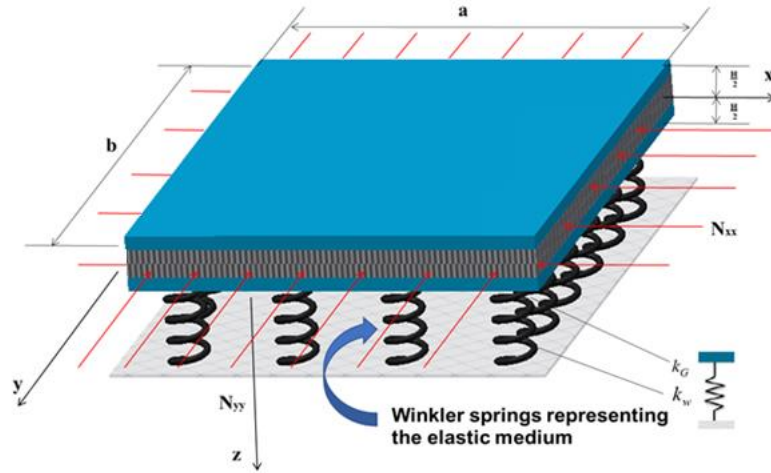
To use the laminated composite plates efficiently, it is necessary to develop appropriate analysis theories to predict accurately their structural and dynamical behavior. Currently, the analysis of the behavior of the laminated plates is an active research area because of their complex behavior [1]. The structural instability becomes an important concern in a reliable design of composite plates. Several studies on laminated plates stability were concentrated on rectangular plates [2-5]. It is known that buckling strength of the rectangular plates depends on the boundary conditions [3], plies orientation [3,4,6] and geometrical ratio [3,5-7]. The thin composites structures which are largely used become unstable when they are subjected to mechanical or thermal loadings which leads to buckling.

To predict buckling load and deformation mode of a structure, the linear analysis can be used as an evaluation technique [8]. The analysis of the laminated plates is more complicated than the analysis of an isotropic and homogeneous material [9]. Finite element method is used for the analysis of the buckling behavior of the notched antisymmetrical fibers plates under compression [10]. The majority of the investigations on laminated plates utilize either the classical lamination theory (CLT), or the first-order shear deformation theory (FSDT).

The main contribution of this work is to perform a composite laminated plates analysis by using the Classical Laminated Plate Theory (CLPT) is described in [11-13]. Various geometries of the plates subjected to compressive load are studied.

### THEORETICAL FORMULATION

Let us consider composite plate the length of  $a$ , width  $b$  and height  $h$ , as shown in figure 1. The composite plates are surrounded by external elastic medium and subjected to biaxially compression. The external medium is modeled as Pasternak-type foundation which is equivalent to Winkler modulus parameter  $k_w$  and shear modulus parameter  $k_G$  of polymer matrix Fig. 1.



**Fig. 1.** Schematic diagram of symmetric laminate subjected to biaxial compression

Bending displacements of the plate-1 and plate-2 are  $w_1(x, y, t)$  and  $w_2(x, y, t)$ , respectively. It was assumed that each composite plate had the length,  $a$  and width,  $b$ . We assume that composite plates are biaxially compressed by forces  $N_{xx}$  and  $N_{yy}$  in the directions of  $x$  and  $y$  axes.

### Governing equations of biaxially compressed composites plates

The governing equation for biaxially compressed orthotropic composite plate embedded in an elastic medium [14], which is based on Classical Laminated Plate Theory CLPT, have following form

$$D_{11} \frac{\partial^4 w}{\partial x^4} + 2(D_{12} + 2D_{66}) \frac{\partial^4 w}{\partial x^2 \partial y^2} + D_{22} \frac{\partial^4 w}{\partial y^4} + N_x \frac{\partial^2 w}{\partial x^2} + N_y \frac{\partial^2 w}{\partial y^2} + k_w w - k_G \left( \frac{\partial^2 w}{\partial x^2} + \frac{\partial^2 w}{\partial y^2} \right) = 0 \quad (1)$$

We assume that composite plate is biaxially compressed in the directions of  $x$  and  $y$  axes,  $N_x = N_y$ . Now we can define compression ratio which equals the ratio between the forces acting in  $y$  and  $x$  directions

$$\delta = \frac{N_{yy}}{N_{xx}} \rightarrow N_{yy} = \delta N_{xx} \quad (2)$$

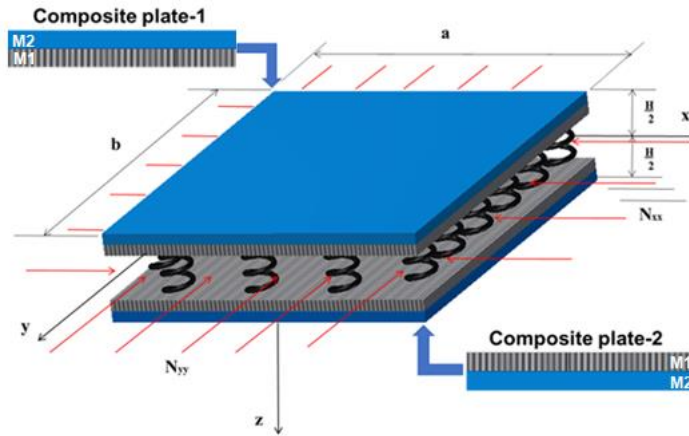
Substitution of equation (2) in equation (1) we derive the general form of governing equation

$$D_{11} \frac{\partial^4 w}{\partial x^4} + 2(D_{12} + 2D_{66}) \frac{\partial^4 w}{\partial x^2 \partial y^2} + D_{22} \frac{\partial^4 w}{\partial y^4} + N_x \left( \frac{\partial^2 w}{\partial x^2} + \delta \frac{\partial^2 w}{\partial y^2} \right) + k_w w - k_G \left( \frac{\partial^2 w}{\partial x^2} + \frac{\partial^2 w}{\partial y^2} \right) = 0 \quad (3)$$

Before solving constituent equation (3), boundary conditions should be defined. In this study it is assumed that all edges on both nanoplates are simply supported. This means that both the displacements and moments at the composite plate edges are zero. This can be expressed by following equations

$$w_i(0, y, t) = 0, \quad w_i(a, y, t) = 0, \quad w_i(x, 0, t) = 0, \quad w_i(x, b, t) = 0 \quad i = 1, 2 \quad (4)$$

$$M_i(0, y, t) = 0, \quad M_i(a, y, t) = 0, \quad M_i(x, 0, t) = 0, \quad M_i(x, b, t) = 0 \quad (5)$$



**Fig. 2.** Symmetric laminate coupled by an elastic medium

If in the middle of the four-layer laminate system we insert an elastic medium that separate the laminate into two symmetric parts, we will have two composite plates with two laminae (Fig. 2.) whose main equations are:

Plate 1

$$D_{11} \frac{\partial^4 w_1}{\partial x^4} + 2(D_{12} + 2D_{66}) \frac{\partial^4 w_1}{\partial x^2 \partial y^2} + D_{22} \frac{\partial^4 w_1}{\partial y^4} + N_x \frac{\partial^2 w_1}{\partial x^2} + N_y \frac{\partial^2 w_1}{\partial y^2} + k_w (w_1 - w_2) - k_G \nabla^2 (w_1 - w_2) = 0 \quad (6)$$

Plate 2

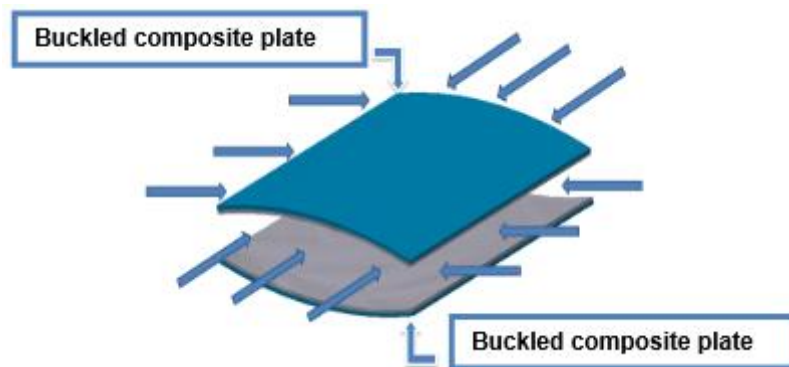
$$D_{11} \frac{\partial^4 w_2}{\partial x^4} + 2(D_{12} + 2D_{66}) \frac{\partial^4 w_2}{\partial x^2 \partial y^2} + D_{22} \frac{\partial^4 w_2}{\partial y^4} + N_x \frac{\partial^2 w_2}{\partial x^2} + N_y \frac{\partial^2 w_2}{\partial y^2} + k_w (w_2 - w_1) - k_G \nabla^2 (w_2 - w_1) = 0 \quad (7)$$

$$\nabla^2 = \frac{\partial^2}{\partial x^2} + \frac{\partial^2}{\partial y^2} \quad (8)$$

### Buckling loads of biaxially compressed composite plates

In this section different explicit cases of biaxial buckling will be considered. The symmetric laminate is subjected to both biaxial as well as biaxial compressive forces. The cases studied will be composite plates buckling with out-of-phase (asynchronous); in-phase (synchronous); and when one of the composite plates is considered to be fixed.

#### Asynchronous-type buckling (out-of-phase)



**Fig. 3.** Asynchronous-type buckling

Composite plates system is assumed to be bi-axially buckled. Fig. 3. shows the three-dimensional configuration of double composite plates system with the asynchronous sequence of buckling:

$$w_1(x, y, t) - w_2(x, y, t) \neq 0$$

In out-of-phase, sequence of buckling the nanoplates is buckled in opposite directions. We evaluate the buckling load for asynchronous-type buckling and use equations (6,7) for the biaxial buckling solution of double composite plates system.

Subtracting equation (6) from equation (7) we get:

$$D_{11} \frac{\partial^4 w}{\partial x^4} + 2(D_{12} + 2D_{66}) \frac{\partial^4 w}{\partial x^2 \partial y^2} + D_{22} \frac{\partial^4 w}{\partial y^4} + N_x \frac{\partial^2 w}{\partial x^2} + N_y \frac{\partial^2 w}{\partial y^2} + 2k_w w - 2k_G \left( \frac{\partial^2 w}{\partial x^2} + \frac{\partial^2 w}{\partial y^2} \right) = 0 \quad (9)$$

$$w = w_1 - w_2 - w_2 + w_1 = 2w_1 - 2w_2 = 2(w_1 - w_2) = 2w \quad (10)$$

We assume that the buckling mode of the double-nanoplate system as

$$w = \sum_{m=1}^{\infty} \sum_{n=1}^{\infty} W_{mn} \sin(\alpha x) \sin(\beta y) \quad (11)$$

In the upper equation:

$$\alpha = \frac{m\pi}{a},$$

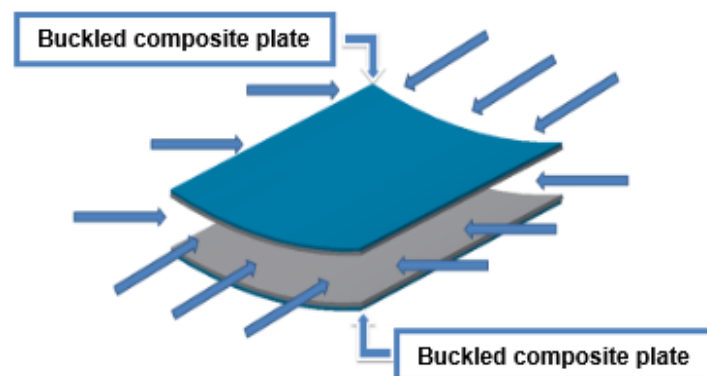
$$\beta = \frac{n\pi}{b} \quad (12)$$

where m and n are the half wave numbers.

Substituting equation (11) into equation (9), we get critical buckling load for asynchronous type of buckling

$$N_{cr} = \frac{D_{11}\alpha^4 + 2(D_{12} + 2D_{66})\alpha^2\beta^2 + D_{22}\beta^4 + 2k_w + 2k_G(\alpha^2 + \beta^2)}{(\alpha^2 + \beta^2)} \quad (13)$$

#### Synchronous-type buckling (in-phase)



**Fig. 4.** Synchronous-type buckling

The schematic illustration buckling of the orthotropic composite plates in-phase is shown in Fig. 4, which is the first mode synchronous type buckling. For the present system, the relative displacements between the two composite plates are



$$w_1(x, y, t) - w_2(x, y, t) = 0$$

In synchronous buckling state, the double composite plates system can be considered to be as one of the composite plates.

We apply the same procedure as earlier for solving equations

Following procedure similar to that of out-of-phase buckling, critical buckling load for synchronous type of buckling can be written as

$$N_{cr} = \frac{D_{11}\alpha^4 + 2(D_{12} + 2D_{66})\alpha^2\beta^2 + D_{22}\beta^4}{(\alpha^2 + \delta\beta^2)} \quad (14)$$

Biaxial compression of double composite plates system can be effectively treated as a single composite plate because for this case the critical buckling load is independent of the stiffness of the coupling springs.

### Buckling with one composite plate fixed

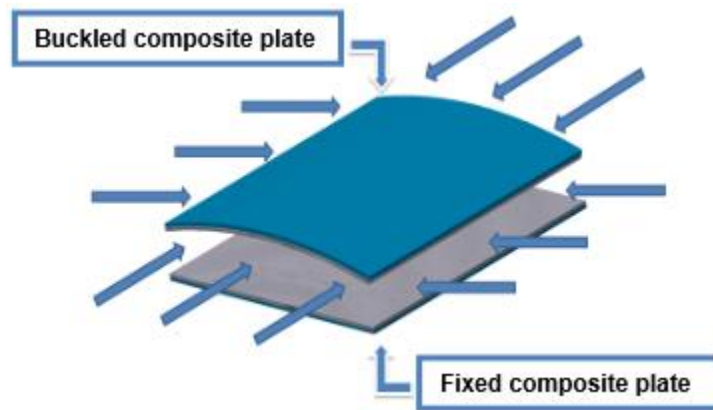


Fig. 5. Buckling with one composite plate fixed

Consider the case of composite plates system when one composite plate is stationary  $w_2 = 0$  which is shown in figure 5. Critical buckling load for this type of buckling can be written as

$$N_{cr} = \frac{D_{11}\alpha^4 + 2(D_{12} + 2D_{66})\alpha^2\beta^2 + D_{22}\beta^4 + k_w + k_G(\alpha^2 + \beta^2)}{(\alpha^2 + \delta\beta^2)} \quad (15)$$

In fact, when one of the composite plates in composite system is fixed ( $w_2 = 0$ ), the composite system behaves as composite plate on an elastic medium.

### NUMERICAL RESULTS

This section shows analysis of four-layer symmetric laminate made of two types of materials:

-Kevlar 49/CE 3305 (material M1)

-Graphite-Epoxy AS-1/3501-5A (material M2)

For laminates of total thickness of 1mm with four sheets of individual thickness of 0.25mm, bending stiffness matrix D has the following form [14]:

$$D_{ij} = \frac{1}{3} \sum_{k=1}^N (\bar{Q}_{ij})^k (h_k^3 - h_{k-1}^3)$$

$$\begin{aligned}
 &= \frac{1}{3}(\bar{Q}_{ij})_{\theta} (h_1^3 - h_0^3) + \frac{1}{3}(\bar{Q}_{ij})_{\theta} (h_2^3 - h_1^3) + \frac{1}{3}(\bar{Q}_{ij})_{\theta} (h_3^3 - h_2^3) + \frac{1}{3}(\bar{Q}_{ij})_{\theta} (h_4^3 - h_3^3) \\
 &= \frac{1}{3}(\bar{Q}_{ij})_{\theta} [(-0,25)^3 - (-0,5)^3] + \frac{1}{3}(\bar{Q}_{ij})_{\theta} [(0)^3 - (-0,25)^3] + \frac{1}{3}(\bar{Q}_{ij})_{\theta} [(0,25)^3 - (0)^3] + \\
 &\frac{1}{3}(\bar{Q}_{ij})_{\theta} [(0,5)^3 - (0,25)^3]
 \end{aligned}$$

Based on the above expression and using the MATLAB software package, bending stiffness matrix for selected laminate schemes  $\theta = 0^{\circ}, 30^{\circ}, 45^{\circ}, 90^{\circ}$  are obtained.

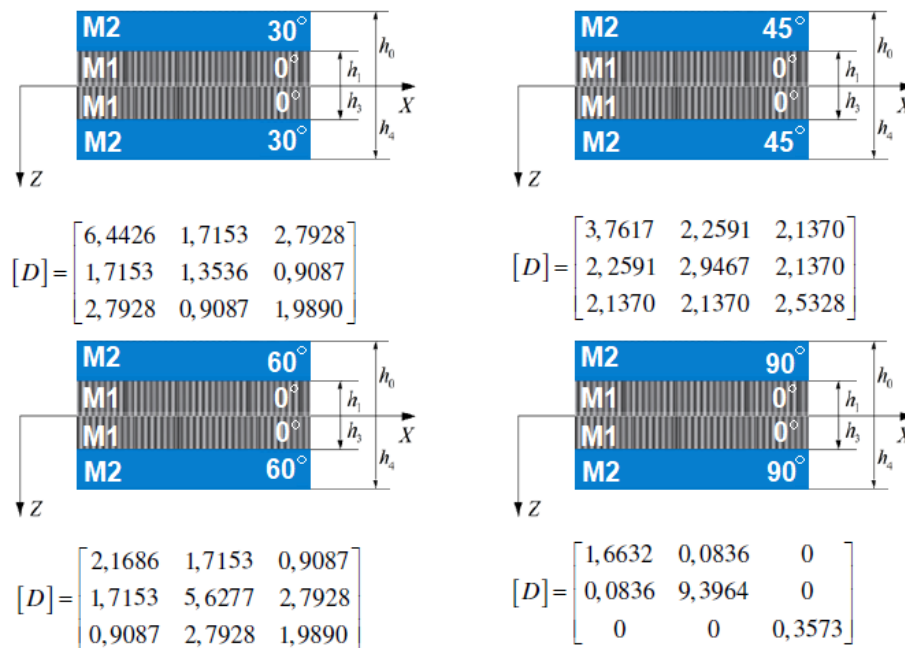


Fig. 6. Schematic layout of symmetric laminate with bending stiffness matrix

Substituting the values of bending stiffness matrix in the previously set equations we obtain values of non-dimensional critical force for three types of buckling.

Based on equations (13), (14) and (15), in this section follows analysis of carbon fiber orientation angle on the non-dimensional buckling load. Nondimensional buckling load is calculated for the value of Winkler modulus  $k_w = 10N / m^3$  while the shear modulus parameter  $k_G = 1N / m$ . The number of half waves was  $m = 1$ ,  $n = 1$ , while the compression ratio was  $\delta = 2$ . The thickness of one composite plate is  $h = 0,25$  mm, while the length takes values within  $a=0-0,6m$  range and width takes value  $b=0,3$ .

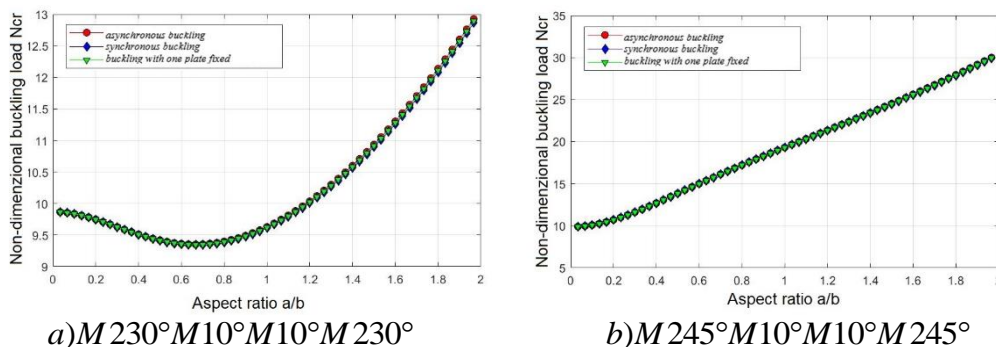
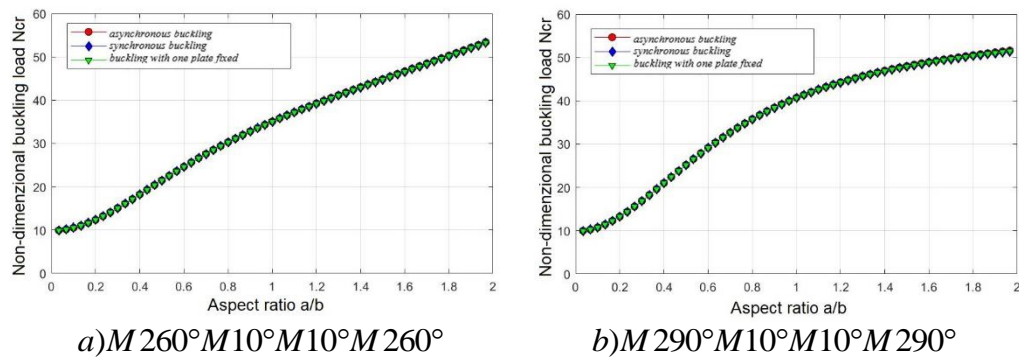


Fig. 7. Effect of carbon fiber orientation angle on non-dimensional buckling load



**Fig. 8.** Effect of carbon fiber orientation angle on non-dimensional buckling load

It can be concluded that for different values of fiber orientation angle, the curves are very close together for all three buckling types. For value of fiber orientation angle  $45^\circ, 60^\circ, 90^\circ$  (Fig. 7-b and Fig. 8-a, 8-b) the non-dimensional critical force value is constantly increasing. The critical force has a minimum only for fiber orientation angle  $30^\circ$  and aspect ratio  $a/b=0,7$  (Fig. 7-a). A very small value of the non-dimensional critical force leads to the deformation of the composite plates and the occurrence of instability of the system.

## CONCLUSION

In this paper, there are analytical expressions for non-dimensional buckling load for three characteristic cases of buckling of simply supported composite plates. Based on CLPT, in this paper was analyzed influence of fiber orientation angle and aspect ratio  $a/b$  on the non-dimensional buckling load on biaxial compressed composite plates embedded in elastic medium.

It has been shown that with the change of fiber orientation angle, the value of the non-dimensioning critical load is changed for all three characteristic buckling cases. Laminate have different minimum and maximum values of non-dimensional critical force at the same value of aspect ratio. For laminate with fiber orientation angle  $M230^\circ M10^\circ M10^\circ M230^\circ$  non-dimensional critical buckling has minimum.

## REFERENCES

- [1] Arslan, R., Agricultural and Economic Potential of Biodiesel in Turkey, Energy Sources, Part B: Economics, Planning, and Policy, No.2, pp. 305-310, 2007.
- [2] Kaw, K., Mechanics of Composite Materials, 2nd Edition, Taylor & Francis, Group, CRC Press, New York, 2006.
- [3] Muc, A., Optimal fibre orientation for simply-supported angle-ply plates under biaxial compression. Composite Structures, 9:161–72, 1988.
- [4] Mijuskovic, O., Coric, B., “Analytical procedure for determining critical load of plates under variable boundary conditions,” Gradevinar, III (vol64), pp.185-194, 2012.
- [5] Nemeth, MP., Buckling behavior of compression-loaded symmetrically laminated angle-ply plates with holes, AIAA Journal, 26:330–6, 1988.
- [6] Vellaichamy, S., Prakash, BG. and Brun, S., Optimum design of cutouts in laminated composite structures, Computers and Structures, 37:241–6, 1990.
- [7] Zor, M., Sen, F., Toygar, ME., An investigation of square delamination effects on the buckling behavior of laminated composite plates with a square hole by using three-dimensional FEM analysis, J Reinf Plast Compos, 24:1119–30, 2005.
- [8] Shufrin, I., Rabinovitch, O., Eisenberger, M., Buckling of laminated plates with general boundary conditions under combined compression, tension, and shear-A semi-analytical solution, Thin-Wall Struct, 46:925–38, 2008.
- [9] CW, Hong CS., Kim, CG., Postbuckling strength of composite plate with a hole, J Reinf Plast Compos, 20:466–81, 2001.

- [10] Ghannadpour, SAM., Najafi, A., Mohammadi, B., On the buckling behavior of crossply laminated composite plates due to circular/elliptical cutouts, *Compos Struct*, 75:3–6, 2006.
- [11] Hamani, N., Ouinas, D., Benderdouche, N., Sahnoun, M., Buckling analyses of the antisymmetrical composite laminate plate with a crack from circular notch. *Advanced Materials Research*. vol.365 pp. 56-61, 2012.
- [12] Reddy, JN., *Mechanics of Laminated Composite Plates and Shells: Theory and Analysis*, CRC Press LLC, London and New York, 2004.
- [13] Spencer, A.J.M. *Constitutive Theory for Strongly Anisotropic Solids in Continuum Theory of the Mechanics of Fibre Reinforced Composites*, Springer-Verlag, Wien, 1984.
- [14] Powell, P.C. *Engineering with Fibre-Polymers Laminates*, Chapman & Hall, England, 1994.
- [15] Jeremić, D. *Analiza stabilnosti laminantnih kompozitnih ploča*, Master Thesis, East Sarajevo, 2013.

## NEWS IN INDUSTRIAL APPLICATION OF CATHODIC CAGE PLASMA NITRIDING

Željko Stojanović<sup>1</sup>, Slavica Prvulović<sup>2</sup>, Sanja Stanisavljević<sup>2</sup>, Mila Kavalić<sup>3</sup>

<sup>1</sup>"Šinvoz" Ltd., Belgrade St. BB, Zrenjanin, Serbia

<sup>2</sup>University of Novi Sad, Technical faculty "Mihajlo Pupin", Zrenjanin, Serbia

<sup>3</sup>Student at University of Novi Sad, Faculty of Technical Science, Novi Sad, Serbia

e-mail: [zstojanovic@sinvoz.rs](mailto:zstojanovic@sinvoz.rs)

**Abstract:** The paper presents innovations in the development and industrial application of cathodic cage plasma nitriding technology (CCPN), whose relevance has become more pronounced in recent years due to the existence of aspiration to eliminate some shortcomings of conventional plasma nitriding, such as edge effect, hollow cathode effect and similarly. The paper discusses the effects of pulsed current application in the cathodic cage plasma nitriding process on the tribological and corrosive properties of non-alloy steels and stainless steels. The paper deals with the analysis of completely new and innovative techniques based on duplex plasma nitriding technology with the combined use of cathode cages made of different materials, such as aluminum (Al) and austenitic steel (ASS). Improved hardness, reduced wear rate, significantly improved corrosion resistance, lower friction coefficient, duplex treatment capability with appropriate treatment sequence and the low treatment temperature suggest the justification and suitability of the technique for industrial application.

**Key words:** cathodic cage plasma nitriding, hardness, coefficient of friction, wear, corrosion

### INTRODUCTION

Abrasive wear is responsible for intensive degradation of machine parts or tools. Methods of increasing the life time are based on application of abrasion resistant materials or creation of hard, wear-resistant surface layers or coatings on the surfaces of machine parts or tools [1]. One of the ways to obtain high complex surface physical and mechanical properties of metallic materials such as hardness, wear resistance, contact fatigue, corrosion resistance and others is chemical heat treatment method - nitriding [2]. In the beginning, the gas and salt bath techniques were introduced; yet, unfortunately, they exhibited certain unavoidable shortcomings [3]. Notably, they consume a much higher quantity of gases due to longer processing time and pose significant environmental issues [4-12]. As an alternative approach, plasma nitriding technique was introduced (PN). This method is termed as conventional plasma nitriding (CPN). The conventional dc plasma nitriding (DCPN) has been industrially accepted, being used to improve several physical properties of metallic surfaces as hardness, wear and corrosion resistance that contribute to increase the use of the nitrided samples. This process presents advantages in comparison with the conventional nitriding processes, for example, the non-emission of pollutants, energy economy and lesser treatment time, although there are some inconveniences to treat components with complex geometry [13,14].

Most of the authors positively describe the effects of surface ion nitriding. On the other hand, there are also reports on adverse effects of direct current and pulsed direct current plasma nitriding on ferrous materials performance [15,16]. However, there are some drawbacks as a hollow cathode effect, the border effect, not uniform temperature and arcing, specially in treating complex geometry samples [17]. The disadvantages linked with CPN can be eliminated by using cathodic cage plasma nitriding (CCPN), in which a cathodic metallic screen surrounds samples - that's why it is called cathodic cage [3]. The samples were placed on an isolant substrate, remaining in a floating potential, and then it was treated in a post-discharge. In this process, the edge effect was completely eliminated, since the plasma was formed on the cage and not directly onto the samples. In this paper, the results in the development and application of the procedure of CCPN are investigated on various wearing materials, which provided an insight into the previous efforts to optimize the processing parameters and the properties of the worn substrate.

## REASONS FOR RESEARCH AND DEVELOPMENT OF CCPN

In the DCPN treatment, plasma is generated directly on the workpiece leading to various problems: edge effect and hollow cathode effect. Typical technological problem is the edge effect that can be observed along the edges and corners of the samples, where nitrogen can diffuse into these parts from multiple directions which result in a nitride network along the particle boundaries (Fig. 1) [18]. The edge effect can be easily observed as the workpiece color is not uniform, and this effect can result in the embrittlement of the effected edges and corners, causing the easier break of the corners for example. (Fig. 2). These defects are more pronounced in steels that contain elements capable to form nitrides, like Cr and Mo, making unviable the application of plasma nitriding in pieces like knives, springs, matrixes and gears, where a high degree of uniformity in the superficial mechanical properties is necessary. In mild-steel cases, like AISI 1020 steel, these defects are less pronounced [19].

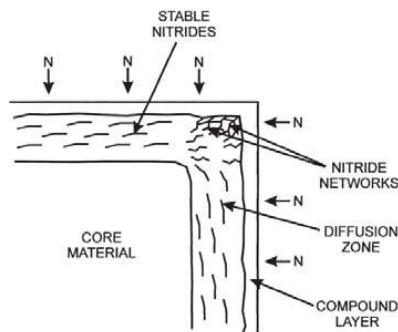


Fig. 1. Corner effect [16]

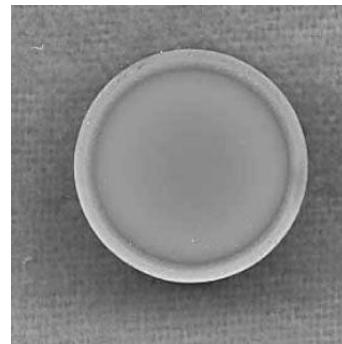


Fig. 2. In the sample treated by the DCPN process, the edging effect, which showed a ring with a different color from the central area of the sample surface, was observed [20]

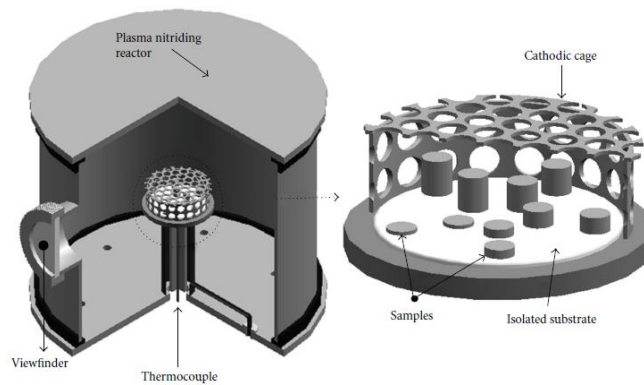
Arcing, which is caused, for example, by organic degassing in a localized area of a component's surface, can produce extremely high local temperatures. This can cause localized melting and/or sputtering away of material from this point on the surface [16]. The roughness of the DCPN-treated sample can be high because of arcing on the sample surface during nitriding [21]. Hollow cathode effect arises when plasma nitriding complex-shaped objects with deep holes, especially blind holes which prevent gas movement through them. This can lead to overionization inside the hole where gas is entrapped, and can lead to uncontrolled heating. The hollow cathode effect appears when the closely located parts facing each other are placed at such a short distance that negative glows contact each other or even overlap [22,23]. Samples with different dimensions when treated through plasma nitriding show a thermal gradient between the treated samples surface and their basis. In the case of a 10 mm height sample, for instance, such a temperature difference may reach 100°C [17].

## CATHODIC CAGE PLASMA NITRIDING

### Process theory

CCPN is technique derived from the active screen plasma nitriding (ASPN), recently developed, to eliminate totally such edge effect [13]. This technique presents some advantages compared to the conventional method, including process efficiency and the production of layers with uniform thickness. The samples are totally involved by a metallic cage, where a high cathodic potential is applied, so the plasma is not formed directly on the sample surface, but in the cathodic cage. A ceramic disk is placed on the samples holder in order to electrically isolate the samples from the cathode. Besides, the temperature inside the nitriding chamber is uniform, and the thermal gradient is very small [14,24]. In this configuration, the glow discharge is isolated from the samples' surface, and samples are at floating or at comparatively lower potential. Such isolation of discharge eliminates the

problems linked with CPN. [3]. The great advantage of this procedure is that it is very versatile, simple and inexpensive. A schematic picture of the plasma reactor is shown in Fig. 3.

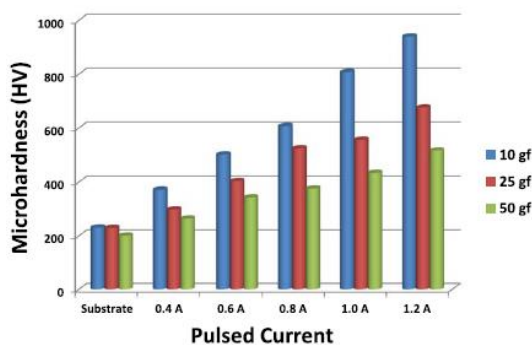


**Fig. 3.** Schematic picture of the plasma reactor with the cathodic cage device, showing the disposition of samples with different heights [14]

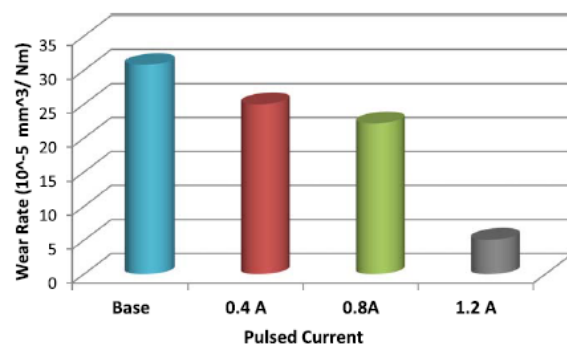
It consists of a cylindrical chamber made in stainless steel in which the negative polarized electrodes are applied and the rest of the chamber held at ground potential (anode). The cage is manufactured with 316 stainless steel. The holes have a uniform distribution, while insulated aluminum oxide disk function as the sample holder.

### IMPROVEMENT OF SURFACE PROPERTIES OF NON-ALLOYED AND STAINLESS STEELS

For non-alloyed steels, this process is not very productive because of in-depth diffusion of nitrogen atoms, and as a result, iron nitrides are established at higher depths. It is reported in the literature that if alloyed and non-alloyed steels are processed simultaneously by conventional plasma nitriding (CPN), surface properties of non-alloyed steel are not significantly improved. Recently is found that CCPN can significantly improve the surface properties of non-alloyed steels [25]. In literature [25] the samples of non-alloyed steels are nitrided in fixed processing conditions while using variable pulsed current. The variation of micro-hardness as a function of pulsed current at multiple loads is plotted in Fig. 4. The hardness of base material at multiple loads (10, 25 and 50 gf) is about 200 HV. After the nitriding process, hardness is found to be enhanced under all processing conditions, and maximum hardness is found at a highest pulsed current of 1.2 A. The hardness shows a linear trend with the pulsed current.



**Fig. 4.** Hardness variation (at various loads) as a function of pulsed current [25]



**Fig. 5.** Wear rates of substrate and samples nitrided at various pulsed currents. [25]

The trend of hardness with current remains similar at multiple loads, however, hardness is decreasing with increasing loads, which is obviously due to the fact that we are moving from surface to the core

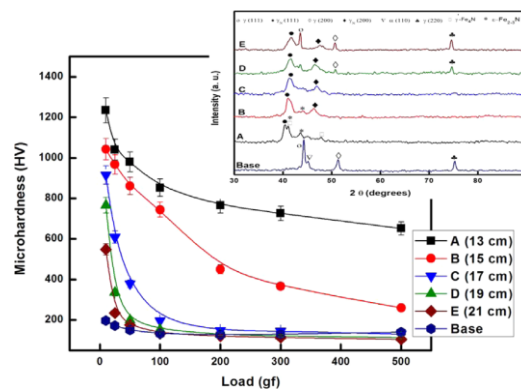
of sample. The wear rates are plotted in Fig. 5. The wear rate is found to be decreased with increasing pulsed current. This tendency is in good agreement with the Archard's equation:

$$V = \frac{kW}{H} \quad (1)$$

where  $H$  is the hardness,  $W$  is the width of wear track,  $V$  is the volume of wear track and  $k$  is wear coefficient. This equation depicts an inverse relation among hardness and wears rates. When the current is highest, dissociation rate of nitrogen is highest due to electrons acceleration, these nitrogen atoms are diffused at interstitial sites. Due to the presence of nitrogen atoms at interstitial sites, slipping probability of atoms (substrate) in the scratching process is reduced, which decrease the wear rates.

The aim of the paper [26] was to investigate the influence of cathodic cage size on active screen plasma nitriding of AISI 304 stainless steels. The specimens are nitrided in fixed processing conditions while using CC with diameters of 13, 15, 17, 19 and 21 cm. The results show that when the CC diameter is reduced, surface hardness profile and corrosion resistance significantly improve, while iron nitrides

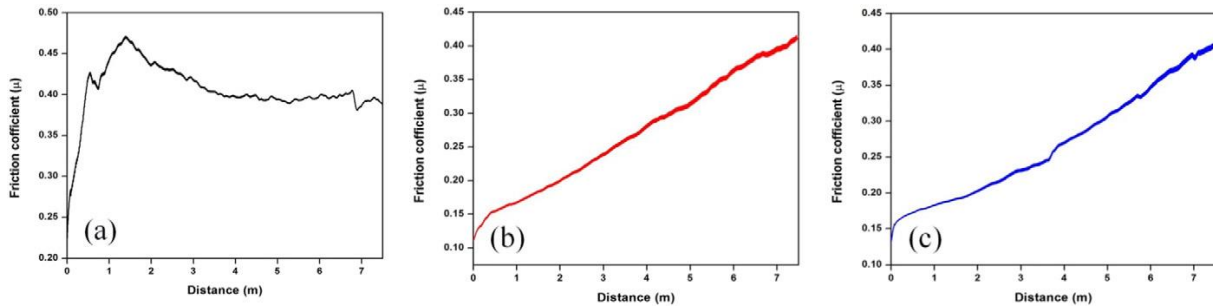
( $Fe_{2-3}N$ ,  $Fe_4N$ ) are formed along with the expanded austenite phase. Fig. 6 shows the hardness profile and XRD analysis of base and processed specimens. For the specimens processed with the smallest CC diameters, A and B, the surface hardness increases even at higher loads. Such improvement in hardness even at higher loads indicates the in-depth penetration of nitrogen in the steel surface.



**Fig. 6.** Hardness profile along with the XRD pattern of base and processed specimens [26]

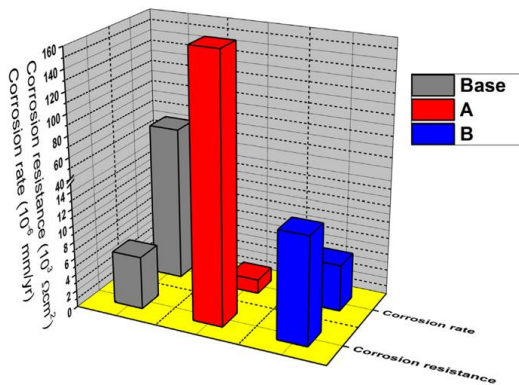
In study [27] plain carbon steel specimens are processed by the cathodic cage plasma nitriding (CCPN) technique using an austenitic stainless steel cathodic cage (CC) having variable diameters (13(A),15(B),17(C),19(D) i 21(E) cm). It is observed that the nitriding process significantly improves the hardness without any pre-treatment or admixing of alloys, which is very useful for industrial applications due to reduced cost and processing time. Also, the corrosion and wear rates are significantly reduced. The friction coefficients of the base and processed specimens against 100Cr6 steel under 1 N load are depicted in Fig. 7. It is observed that the treated specimens show smoother as well as lower friction coefficient over the base samples, and specimen A have the lowest friction coefficient. This decrease in friction coefficient as a result of plasma nitriding can be attributed to the improved surface hardness and high compressive strains.



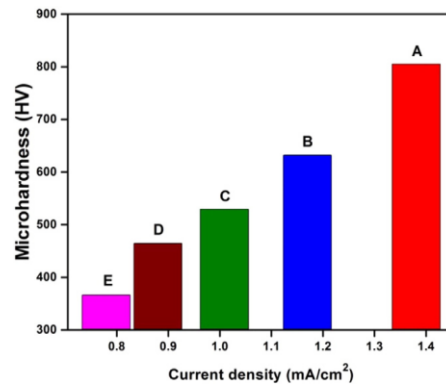


**Fig. 7.** Friction coefficient of (a) base, (b) specimen A, (c) specimen B [27]

The corrosion rate is found to be significantly decreased as shown in Fig. 8. This improvement in the corrosion properties can be attributed to formation of iron nitrides ( $Fe_3N$ ,  $Fe_4N$ ). The specimen processed using small CC shows more improved corrosion resistance, which can be attributed to excess of  $Fe_3N$  phase with higher nitrogen contents. Fig. 9 shows the surface hardness as a function of current density, and it shows a linear correlation between the two quantities. The improved surface hardness here points out the development of harder nitride phases on the surface of treated specimens.



**Fig. 8.** Corrosion resistance and corrosion rates of the base and treated specimens [27]



**Fig. 9.** Influence of current density (by varying CC diameter) on the micro-hardness [27]

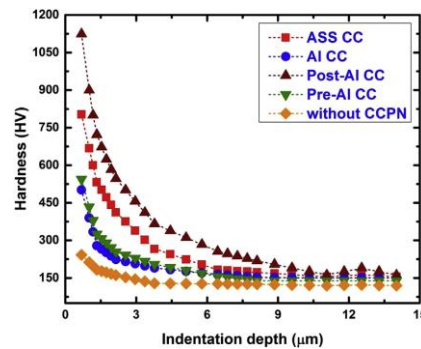
## DUPLEX TECHNOLOGIES WITH THE APPLICATION OF CC MADE OF DIFFERENT MATERIALS

The hard duplex coatings are becoming very popular particularly in the last decade, as they could achieve much better surface properties. During the CCPN process, along with the diffusion of the active plasma species on the surface, cathodic cage material is also sputtered and later deposited on the sample surface. In literature [28] novel duplex plasma nitriding is carried out on AISI-304 steel at fixed temperature of  $400^{\circ}C$ , using aluminum and austenite steel cages. The influence of aluminum cage nitriding is investigated before (pre) and after (post) the austenite steel cage nitriding. The results show that the post aluminum cage nitriding achieves excellent film quality, the highest surface hardness with aluminum nitride as a leading phase.

U paper [29] a duplex cathodic cage plasma nitriding (CCPN) process is performed using aluminum (pre and post treatment) and stainless steel cathodic cages. The duplex treated samples are also compared with the single treatments. It is found that the duplex post-aluminum CC process attains a surface hardness of  $\approx 1124$  HV; far higher than the other treated samples and previously reported in the literature. The crystal structure of post-aluminum nitrided samples shows the dominant aluminum nitride phase. The variation in the hardness of the base material, single and duplex nitrided samples as a function of indentation loads are plotted in Fig. 10.

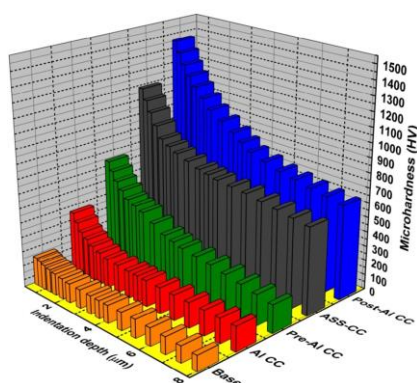
The hardness pattern of samples treated with aluminum CC and pre-Al CC show the sharp gradients with the indentation load, which indicates that hardness is enhanced on the top surface of the layer.

The results from hardness point out that duplex cathodic cage treatment with post-Al CC can be used effectively for non-alloyed steels, which are commonly believed to be unfavorable for nitriding.

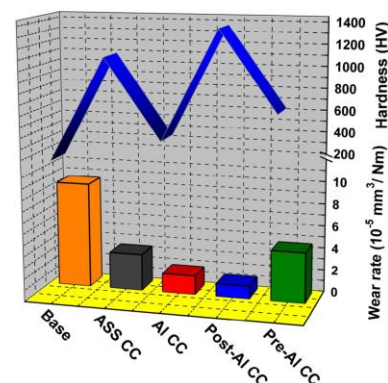


**Fig. 10.** Variation of surface hardness as a function of indentation depth for various samples (untreated material labeled as without CCPN); nitrided by austenite steel cage (marked as ASS CC); nitrided by aluminum cage (labeled as Al CC); initially treated with ASS CC and subsequently treated with Al CC (labeled as post-Al CC); initially treated with Al CC and subsequently treated with ASS CC (labeled as pre-Al CC) [29]

The austenite stainless steel is widely employed in several industries due to exceptional corrosion resistance. Unfortunately, their use is restricted due to low surface hardness and poor wear resistance. In paper [30] the results of duplex treatment samples (first processed by an aluminium cathodic cage (pre-Al CC) and in reverse order (post-Al CC)) are compared with single aluminium, and austenite stainless steel cathodic cage treated samples. The variation in micro-hardness vs. indentation depth for base material, single and duplex nitrided sample is plotted in Fig. 11. It clearly reveals that hardness is enhanced under each treatment condition and a significant increase by duplex nitriding process with post-Al CC. The hardness pattern shows that enhancement in hardness at higher depths except for Al CC sample, which indicates the development of thick modified layer. The wear rate is plotted quantitatively in Fig. 12, which clearly illustrates that best wear properties can be achieved by the post-Al CC nitriding process. Furthermore, it shows that even the hardness is not significantly high and modified layer is quite thin in Al CC treated sample, but still, wear properties can be improved. The better improvement in wear resistance of Al CC treated sample over ASS CC treated sample can be attributed to the AlN phase.



**Fig. 11.** Influence of single and duplex nitriding process on microhardness as a function of indentation depth [30]



**Fig. 12.** Wear rates of single and duplex nitrided samples [30]

The friction coefficient of the base sample, single and duplex nitrided samples as a function of sliding distance and average friction coefficient are plotted in Figs. 13 and 14, respectively. It shows that the base sample has the highest friction coefficient which can be attributed to low hardness and as a result severe wear. Moreover, large variations in friction coefficient as a function of sliding distance is observed, which can be explained as follows: the decreasing step is caused by oxide layer formation,

and the increasing step is caused by the removal of this film upon further sliding. This study shows that duplex treatment with a particular processing specific order is highly beneficial for mechanical, wear and corrosion properties of the sample under consideration.

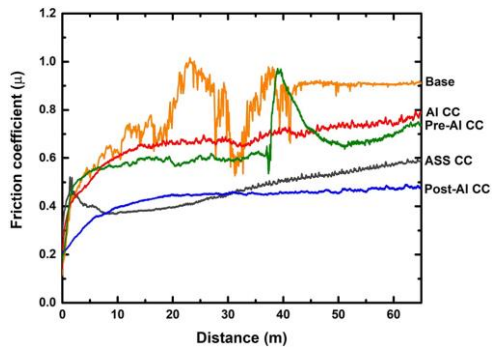


Fig. 13. Friction coefficient of various samples vs. sliding distance [30]

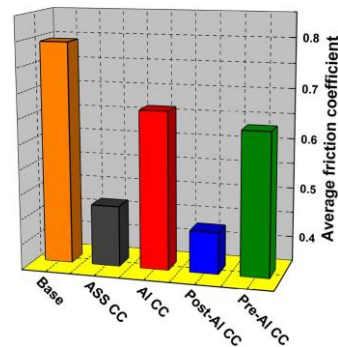


Fig. 14. Average friction coefficient of single and duplex nitrided samples [30]

## CONCLUSION

There are no unified scientific knowledge about the considered improvements by the cathodic cage plasma nitriding procedure within the domestic scientific-professional circles, which points to the conclusion that domestic authors did not deal more comprehensively with research which have aim of studying the influence of pulsed currents, cathodic cage sizes, cathode cage materials, single and duplex coatings on surface hardness, wear and corrosion rates and friction coefficients of different materials mentioned in this paper, so that these methods remained unknown to our wide scientific and professional public. This paper describes the latest and innovative plasma nitriding procedures that offer a significant improvement in conditions and working results, ie improvement of surface layer characteristics that provide longer service life and greater reliability in material behavior. The incentive for the innovative work on the development and improvement of CCPN was given by the shortcomings of the DCPN procedure such as the hollow cathode effect, edge effect, uneven temperature and arcing which produced parts with imperfections which consequently led to changes in material surface, microstructure and mechanical properties. Significant improvement of surface properties of non-alloy and stainless steels was observed by applying increased values of impulse current and use of CC of smaller diameters, while improvement of friction coefficient of carbon steel was due to increase of surface hardness and creation of high compressive residual stresses. A further step in the innovative development of the CCPN process is based on the application of duplex technologies that have proven useful in improving surface properties. The research is mainly focused on understanding the influence of pre and post-treatment with cathodic cages made of appropriate materials on the surface hardness, wear rates and friction coefficient of the treated samples. The best coating quality on non-alloy steel was obtained by initial nitriding in an austenitic steel cage and subsequent nitriding in an aluminum cage. The same results were reported for austenitic steel as the base material, so an improvement in surface hardness and wear properties can be clearly seen by post-treatment in an aluminum cathode cage. It is interesting to note that the mechanical, wear and corrosion properties depend on the correct choice of machining order.

## REFERENCES

- [1] Suchánek, J., Kuklík, V.: Influence of heat and thermochemical treatment on abrasion resistance of structural and tool steels, *Wear*, Vol. 267, pp. 2100-2108, 2009.
- [2] Tarent'ev, V.F., Michugina, M.S., Kolmakov, A.G., Kvedaras, V., Čiuplys, V., Čiuplys, A., Vilys, J.: The effect of nitriding on fatigue strength of structural alloys, *Mechanika*, Vol. 64, pp. 12-22, 2007.

- [3] Naeem, M., Raza, H.A., Shafiq, M., Zaka-ul-Islam, M., Iqbal, J., Díaz-Guillén, J.C., Zakaullah, M.: Effect of pulsed duty cycle control on tribological and corrosion properties of AISI-316 in cathodic cage plasma nitriding, *Mater. Res. Express*, Vol. 4, pp. 1-13, 2017.
- [4] Kuoshe, L., Hongwei, L., Hui, Y., Dunbo, Y., Fengying, W., Shirong, Z., Guocheng, Z.: Surface modification of  $(\text{Tb}_{0.3}\text{Dy}_{0.7})\text{Fe}_{1.95}$  alloy by ion nitriding process, *Journal of rare earths*, Vol. 27, pp. 241-243, 2009.
- [5] Alekseeva, M.S., Gress, M.A., Scherbakov, S.P., Gerasimov, S.A., Kuksenova, L.I.: The influence of high-pressure gas nitriding on the properties of martensitic steels, *Metal Science and Heat Treatment*, Vol. 59, pp. 524-528, 2017.
- [6] Cho, Y.W., Kang, Y.J., Baek, J.H., Woo, J.H., Cho, Y.R.: Investigation of Microstructure, Nanohardness and Corrosion Resistance for Oxi-Nitrocarburized Low Carbon Steel, Vol. 9, pp. 1-10, 2019.
- [7] Đukić, V.: Gas nitriding, book of Mechanical materials, Publisher Independent author's edition, Kragujevac, p. 333.
- [8] Chen, Z.D., Bao, C.X., Cao, Y.: Nitriding Processes of Ferrous Powder Metallurgy Components, *Transactions of powder metallurgy association of India*, Vol. 45, pp. 25-29, 2019.
- [9] Funatani, K.: Low-Temperature Salt Bath Nitriding of Steels, *Metal Science and Heat Treatment*, Vol. 46, pp. 277-281, 2004.
- [10] Jing, Y., Jun, W., Tan, G., Ji, X., Hongyuan, F.: Phase Transformations during Low Temperature Nitrided Inconel 718 Superalloy, *ISIJ International*, Vol. 56, pp. 1076-1082, 2016.
- [11] Podgornik, B., Vižintin, J.: Wear resistance of plasma and pulse plasma nitrided gears, *Gear technology*, Vol. 20, pp. 33-37, 2003.
- [12] Fraczek, T., Ogorek, M., Skuza, Z., Prusak, R.: Mechanism of ion nitriding of 316L austenitic steel by active screen method in a hydrogen-nitrogen atmosphere, *The International Journal of Advanced Manufacturing Technology*, Vol. 109, pp. 1357-1368, 2020.
- [13] Alves, Jr.C., de Araújo, F.O., Ribeiro, K.J.B., da Costa, J.A.P., Sousa, R.R.M., de Sousa, R.S.: Use of cathodic cage in plasma nitriding, *Surface & Coatings Technology*, Vol. 201, pp. 2450-2454, 2006.
- [14] de Sousa, R.R.M., de Araújo, F.O., da Costa, J.A.P., Brandim, A. de S., De Brito, R.A., Alves, C.: Cathodic Cage Plasma Nitriding: An Innovative Technique, *Journal of Metallurgy*, Vol. 2012, pp. 1-6, 2012.
- [15] Łępicka, M., Grądzka-Dahlke, M.: Direct current and pulsed direct current plasma nitriding of ferrous materials a critical review, *Acta Mechanica et Automatica*, Vol. 10, pp. 150-158, 2016.
- [16] Biró, A.S., Trends of nitriding processes, *Production Processes and Systems*, Vol. 6, pp. 57-66, 2013.
- [17] de Sousa, R.R.M., de Araújo, F.O., Ribeiro, K.J.B., Mendes, M.W.D., da Costa, J.A.P., Alves, Jr.C.: Cathodic cage nitriding of samples with different dimensions, *Materials Science and Engineering A*, Vol. 465, pp. 223-227, 2007.
- [18] Kovács, D., Quintana, I., Dobránszky, J.: Effects of Different Variants of Plasma Nitriding on the Properties of the Nitrided Layer, *Journal of Materials Engineering and Performance*, Vol. 28, pp. 5485-5493, 2019.
- [19] Ribeiro, K.J.B., de Sousa, R.R.M., de Araújo, F.O., de Brito, R.A., Barbosa, J.C.P., Alves, Jr.C.: Industrial application of AISI 4340 steels treated incathodic cage plasma nitriding technique, *Materials Science and Engineering A*, Vol. 479, pp. 142-147, 2007.
- [20] Nishimoto, A., Tokuda, A., Akamatsu, K.: Effect of Through Cage on Active Screen Plasma Nitriding Properties, *Materials Transactions*, Vol. 50, pp. 1169-1173, 2009.
- [21] Nishimoto, A., Amano, R., Tamiya, T.: Duplex treatment of active screen plasma nitriding and amorphous hydrogenated carbon coating, *Applied Surface Science Advances*, Vol. 6, pp. 1-7, 2021.
- [22] Shen, L., Wang, L., Xu, J.J.: Plasma nitriding of AISI 304 austenitic stainless steel assisted with hollow cathode effect, *Surface & Coatings Technology*, Vol. 228, pp. S456-S459, 2013.

- [23] O'Brien, M.J., O'Brien & Associates, Goodman, D., Surface Combustion, Inc.: ASM Handbook: Volume 4: Heat Treating: Plasma (Ion) Nitriding of Steels, ASM International, Ohio, 1991.
- [24] de Sousa, R.R.M., de Araújo, F.O., de Carvalho Costa, T.H., Nascimento, I.O., Santos, F.E.P., Alves Júnior, C., Feitor, M.C.: Thin TiN and TiO<sub>2</sub> Film Deposition in Glass Samples by Cathodic Cage, *Materials Research*, Vol. 18, pp. 347-352, 2015.
- [25] Naeem, M., Iqbal, J., Shabbir, F., Khan, M.A., Díaz-Guillén, J.C., Lopez-Badillo, C.M., Shafiq, M.: Effect of pulsed current on cathodic cage plasma nitriding of non-alloyed steel, *Mater. Res. Express*, Vol. 6, pp. 1-13, 2019.
- [26] Naeem, M., Shafiq, M., Zaka-ul-Islam, M., Nawaz, N., Díaz-Guillén, J.C., Zakaullah, M.: Effect of cathodic cage size on plasma nitriding of AISI 304 steel, *Materials Letters*, Vol. 181, pp. 78-81, 2016.
- [27] Naeem, M., Shafiq, M., Zaka-ul-Islam, M., Ashiq, A., Díaz-Guillén, J.C., Shahzad, M., Zakaullah, M.: Enhanced surface properties of plain carbon steel using plasma nitriding with austenitic steel cathodic cage, *Materials and Design*, Vol. 108, pp. 745-753, 2016.
- [28] Naeem, M., Shafiq, M., Zaka-ul-Islam, M., Díaz-Guillén, J.C., Lopez-Badillo, C.M., Ullah, N., Zakaullah, M.: Improved surface properties of AISI-304 by novel duplex cathodic cage plasma nitriding, *Materials Letters*, Vol. 189, pp. 213-216, 2017.
- [29] Naeem, M., Shafiq, M., Zaka-ul-Islam, M., Bashir, M.I., Díaz-Guillén, J.C., Lopez-Badillo, C.M., Zakaullah, M.: Novel duplex cathodic cage plasma nitriding of non-alloyed steel using aluminum and austenite steel cathodic cages, *Journal of Alloys and Compounds*, Vol. 721, pp. 307-311, 2017.
- [30] Naeem, M., Iqbal, J., Zakaullah, M., Shafiq, M., Mujahid, Z.I., Díaz-Guillén, J.C., Lopez-Badillo, C.M., de Sousa, R.R.M., Khan, M.A.: Enhanced wear and corrosion resistance of AISI-304 steel by duplex cathodic cage plasma treatment, *Surface & Coatings Technology*, Vol. 375, pp. 34-45, 2019.

## APPLICATION OF HYBRID TECHNOLOGIES IN THE FUNCTION OF IMPROVING THE PERFORMANCE OF HOT FORGING TOOLS

Željko Stojanović<sup>1</sup>, Slavica Prvulović<sup>2</sup>, Sanja Stanisavljev<sup>2</sup>, Mila Kavalić<sup>3</sup>

<sup>1</sup>"Šinvoz" Ltd., Belgrade St. BB, Zrenjanin, Serbia

<sup>2</sup>University of Novi Sad, Technical faculty "Mihajlo Pupin", Zrenjanin, Serbia

<sup>3</sup>Student at University of Novi Sad, Faculty of Technical Science, Novi Sad, Serbia

e-mail: [zstojanovic@sinvoz.rs](mailto:zstojanovic@sinvoz.rs)

**Abstract:** The paper presents advanced technologies based on the formation of hybrid layers by a combination of modification and coating procedures of materials applied to the surface of hot forging dies and the effect of heat and energy lead to increased service life and tool quality. The use of these double layers are developed from the need to eliminate the disadvantages which single PVD and CVD coatings and PN layers are faced exposed to elastic and plastic deformation of soft steel substrates, ie intensive oxidation and adhesive wear of the upper Fe(N) layer. The paper illustrates the mechanisms of damage and degradation of hot forging die materials as a consequence of long - term interaction between the workpiece and the die material, whereby partial attention is focused on economic benefits achieved by using the above technologies. The results of this research show that the introduction of completely new procedures, by combination of plasma nitriding and PVD coatings as well as the latest innovative double PACVD coatings on appropriately processed base material, has an impact on hot forging die performance, because they have been found to lead to improvement of tribological properties of the die.

**Key words:** hot forging die, plasma nitriding, PVD, PACVD

### INTRODUCTION

The problem of low tool lifetime has long been a subject of interest to many scientific centers around the world. In recent years, in light of continuously growing competition, there has been growing interest in the problem of improving tool lifetime. Metalworking processes, including forging, are a particular group of manufacturing processes, where the tools applied are often very complicated and their lifetime is very short due to heavy-duty working conditions, meaning that, in certain cases, tool costs make up even 30% of total production costs [1]. The wear of forging tools used in hot forging processes is complicated and difficult to analyze, as it is affected by many phenomena, which often occur simultaneously. Among the most important ones, we can name thermo-mechanical fatigue, plastic deformation, abrasive wear, and oxidation [2-7]. All these factors simultaneously contribute to the wear of forging tools, while the share of the effect of the particular factors is different depending on the type of the tool (its size, shape, and production manner) as well as on the operation conditions (type of the forging aggregate, pressures, process temperature, etc.) [2].

The effective way to improve the durability of forging dies is a modification of the surface properties by the constitution of layers or coatings having appropriate properties [7]. Here, new elements are diffused into the surface usually at elevated temperatures so that the outer layers are changed in a composition and properties compared to those of the bulk [8]. Among various methods of surface treatments, PN is considered as one of the promising methods as this process provides of high surface hardness, fatigue strength, corrosion and wear resistance along with the low coefficient of friction [9,10]. In recent years, many new solutions have also been developed in the field of methods improving the lifetime of forging tools. Among these solutions, hybrid layers are dominant, i.e., those combining various surface treatment methods for the purpose of obtaining new properties and higher wear resistance [6]. The most widely used surface treatment technology is a combination of plasma nitriding of the die surface layer with subsequent deposition of hard antiwear coating by means of the PVD (Physical Vapour Deposition) methods often called a duplex technology [10]. Thanks to lowering the temperature of CVD processes (in the PECVD process) it became possible to use CVD coatings for building layers based on nitrided layer [11]. It is to be expected that in the future combined procedures will be the most developed, because they achieve even better properties [12]. With this paper, the authors presented the latest research directions and the main focus of development of surfaces modification procedures of tool steels for hot work using plasma-based technologies,

which provided a more complete insight into the composition and properties of layers and coatings built with the aim of providing protection against the most difficult working conditions which prevailing on the surfaces of the dies.

### DAMAGE OF CRITICAL AREAS OF HOT FORGING TOOLS

In today's engineering, forging has become an important process for manufacturing parts. [13]. Working life of the dies is an important consideration from the point of view of cost reduction associated with tool replacement and maintenance and improvement in productivity and product quality [14]. In the last years, metalworking industries have shown great interest in improving service life of tools used in hot working operations, such as hot forging [15]. The cycle of a hot forging operation is schematically shown in Fig. 1. At first the billet is heated up to 1000-1250°C and positioned in the lower die. After forming the shape under high mechanical loads, the finished part is ejected from the die. Afterwards, the dies are mostly cooled using air and a mixture of water and lubricant to decrease friction during the following forging step [16].

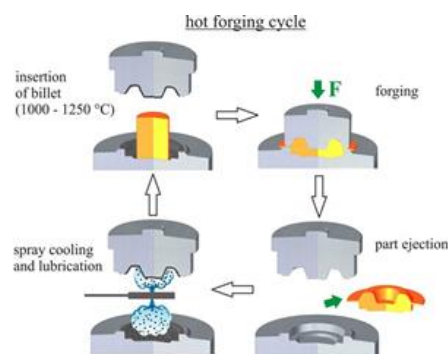


Fig. 1. Cycle of a hot forging process [16]

During the forging process, dies are heavily loaded and exposed to complex loading conditions, combining thermal, mechanical, tribological and chemical loadings [17-20]. The most of hot forging die failures are caused by inadequacy of influencing variables such as die materials, design, manufacturing and forging operations [21]. Fig. 2 shows two worn forging dies after about 10000 strokes.



Fig. 2. Appearance of two closed-die forging dies after about 10000 cycles [22]

Although the tool steel is the same in both cases, it is obvious that the dominant damage mechanism is slightly different, which can only be explained by differences in the local loading conditions. On the right hand side, thermal fatigue was dominant, whereas the die on the left hand side has predominantly seen abrasion. Under high process temperature conditions, work piece and tool material may stick together causing adhesive wear (Fig. 3a). Additionally, the oxidation of the work piece surface creates hard particles like scale which cause extensive abrasive wear. During production, the thermal load from material processing will be followed by cooling cycles which provokes thermal shock conditions (Fig. 3b).



Fig. 3. Main wear mechanisms in examined forging tools in the mainly loaded regions [3]

On forging tools, wear is responsible for tool failure in 70%, mechanical cracking in 25%, thermal cracking in 2% and plastic deformation in 3% of failure cases [23]. The main component of the total cost is the die cost which is closely related to the die life. The die cost is of about 30% of the total cost for a closed die forging process. Hence, an increase of 100% in the die life can reduce the total cost of about 15% [8,1,2,5,10]. In light of this, increasing tool durability is a critical challenge in the manufacture of die forgings. Improved durability contributes to lowering the unit cost of manufacturing a forging and ensures stability and greater output of the production process [24].

### THIN LAYERS AND COATINGS APPLIED BY PN/PVD TECHNIQUE

#### Notes before analysis

To improve the mechanical and tribological properties, various PVD coatings have been largely employed. Among the wear resistance PVD coatings, titanium-containing coatings such as TiN, TiC, TiCN and TiAlN have been of great interest since they have high hardness, low friction coefficient and high wear resistance [25-29]. Since PVD coatings are very thin, the applied forces must be mostly supported by the substrate. So, high elastic and plastic deformation of unhardened steel substrates results in decreasing the wear resistance and the adhesion of the coating systems [30]. The combination of plasma nitriding and PVD hard coatings should be the next step of performance improvement of hot forging tools. Plasma nitrided tool steel surface provides better mechanical support for the hard coating than the original hot working tool steel. The combination of plasma nitriding and PVD hard coating may also increase the thermal fatigue resistance due to high residual stresses [31]. Two combined hardened surface layers, i.e., the plasma nitrided layer and the PVD coating, result in their synergic interaction [10]. The coating protects the nitrided substrate against oxidation and local damage, while the diffusive layer of nitrides forms a stable substrate of varying hardness, constituting an intermediate layer between the relatively soft substrate and the hard coating. This prevents premature cracking and removal of the coating resulting from deformation of the substrate. The beneficial properties resulting from the application of a hybrid layer are shown in Fig. 4.

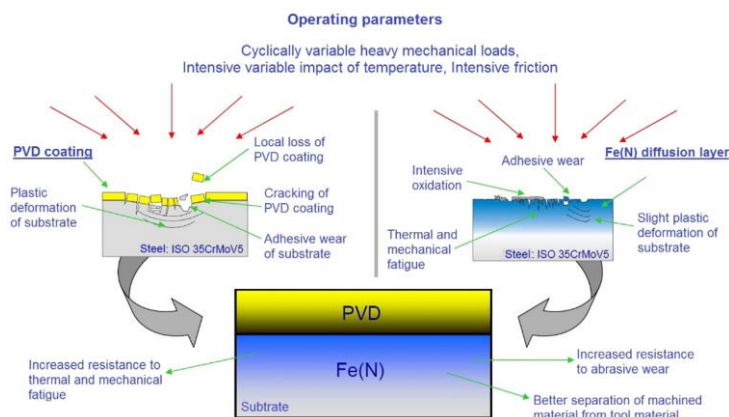
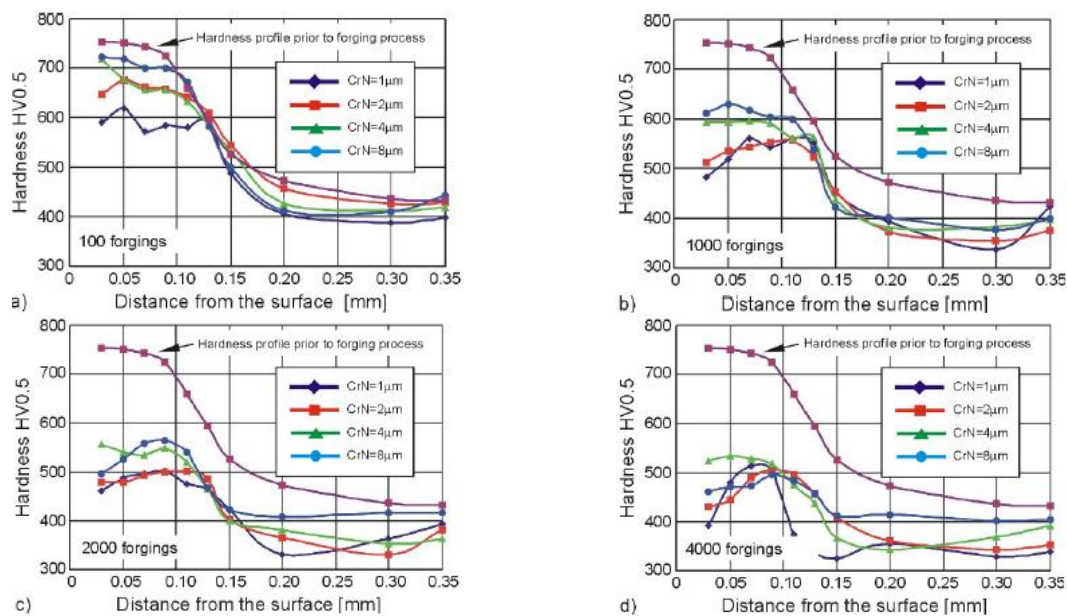


Fig. 4. Structure of hybrid layer containing PVD coating and diffusive layer of nitrides [24]



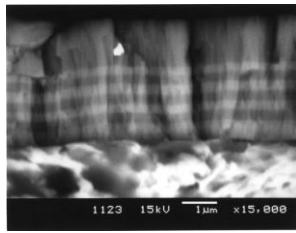
## Improvement of mechanical and tribological properties by PN/PVD technique

Literature [32] presents results which enabled the determination of the role of CrN coating and the influence of its thickness on the effectiveness of hybrid layer "nitrided layer / CrN coating" in the process of increasing the durability of forging dies. The obtained results revealed that for all tested dies, independently from CrN coating thickness, the main mechanisms of their destruction was mechanical and thermal fatigue, and plastic deformation. It has been shown that the main role of CrN coating in the hybrid layer "nitrided layer / PVD coating" is to counteract a high temperature influence the source of which is forging on die material. The hardness change analysis of forging dies at their various maintenance stages (Fig. 5) proved that in the dies' initial maintenance period a factor decisive for limiting the intensity of their wear is, first of all, the thickness of CrN coating. A greater CrN coating thickness reduces the influence of forging temperature on the tempering of the die's material more effectively. Thanks to this the CrN coating with a greater thickness better prevents the decrease of the die's hardness in the forging process and in effect counteracts more effectively the die's plastic deformation.

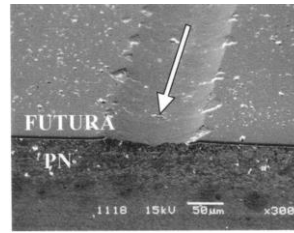


**Fig. 5.** Results of hardness measurements in the distance function from the surface for dies covered with hybrid layer "nitrides layer / CrN" with a different thickness of CrN coating, after their various maintenance time: a) 100 forgings, b) 1000 forgings, c) 2000 forgings, d) 4000 forgings [32]

In paper [33] the surface improvement properties during hot forging of steel parts are considered, by applying multilayer coatings FUTURA and PN+FUTURA. Before the introduction of coated tooling into the forging procedure, they measured the properties of a duplex treatment on polished test plates of H11 tool steel, which were treated together with one set of dies. After plasma nitriding for 8h, they measured a Vickers microhardness of 1100 HV<sub>0,025</sub> through a diffusion depth of 85 μm, while, after nitriding for 24h, the diffusion zone was extended to a depth of approximately 160 μm. The microstructure of the duplex coating on the H11 substrate was studied by SEM analysis of the FUTURA multilayered coating on the plasma nitrided tool steel cross-section, as shown in Fig. 6. The high resistance of such a top coating against wear was also observed during the scratch test (Fig. 7). The scratch test on the duplex coating showed only quantitatively how strong the influence of plasma nitriding is on the adhesion of the top FUTURA coating.

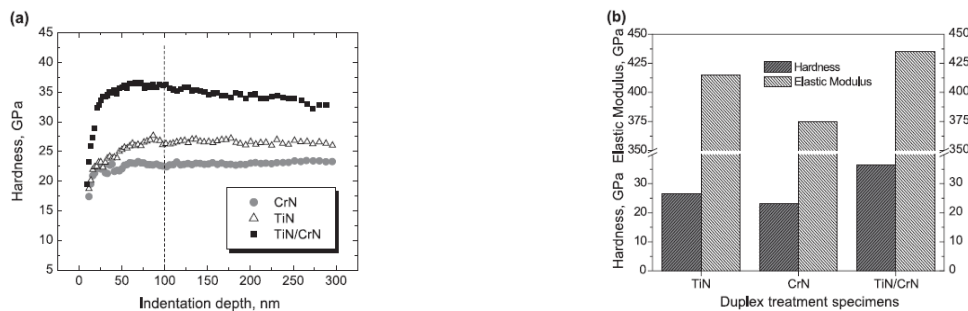


**Fig. 6.** SEM micrograph of a FUTURA coating deposited on a plasma-nitrided H11 test plate [33]



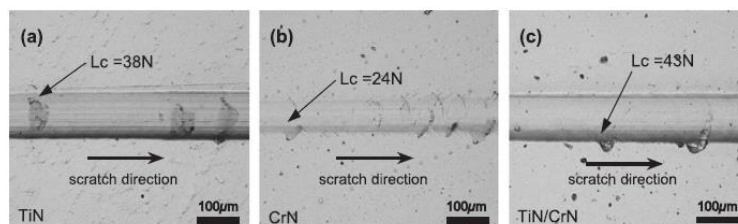
**Fig. 7.** SEM micrograph of a scratch track on an AISI H11 test plate, improved with duplex treatment, as observed at 115N [33]

In literature [34] the effects of duplex treatment consisting of plasma nitriding and PVD hard coating on the surface properties of hot working tool steel were investigated. Three different coatings (TiN, CrN single layer coating and TiN/CrN multi-layer coating) were deposited on pre-plasma nitrided AISI H13 steel using unbalanced magnetron sputtering method. Fig. 8(a) shows the hardness of each coating from the surface to 300nm depth and the values of hardness and elastic modulus determined at the indentation depth of 100nm are showed in Fig. 8(b). The hardness of TiN/CrN multi-layer coating was measured to be approximately 36GPa, which is approximately 1.4 times higher than those of the TiN and CrN single layer coatings (26 and 23GPa, respectively).



**Fig. 8.** The hardness (H) and elastic modulus (E) of each coating deposited on pre-nitrided specimens [34]

The results from scratch adhesion test are illuminated in Fig. 9. Also, in the case of multi-layer coatings, adhesion critical load is higher than that of single layer coatings because of less residual stress. The duplex TiN/CrN multi-layer coating has the highest critical load  $L_c=43N$  among all specimens and showed a much better thermal stability than the duplex CrN coating.



**Fig. 9.** The optical images of scratch tract formed on duplex treated specimens: (a) duplex TiN single layer coating; (b) duplex CrN single layer coating; (c) duplex TiN/CrN multi-layer coating [34]

## THIN LAYERS AND COATINGS APPLIED BY PN/PACVD TECHNIQUE

### Notes before analysis

Today, requirements of coatings with good wear resistance have been increased significantly due to longer life of industrial parts. For example, using plasma in techniques such as PVD and CVD has produced better properties of the applied coatings, meanwhile eliminating many limitations of it. Impossibility of coating the complicated shaped products and high temperature of the process are

among the difficulties for PVD and CVD techniques, respectively. Using plasma can solve the abovementioned problems to a great extent [35,36]. To overcome some of these problems, the plasma-assisted chemical vapor deposition (PACVD) technique tries to combine some of the advantages of both CVD and PVD techniques [37]. The deposition temperature in PACVD is typically in the range between 480 and 510°C, which makes this technique suitable for coating of steel substrates. Another advantage of PACVD is that the load support of relatively soft hot work tool steels can be relatively easily enhanced using plasma nitriding prior to coating deposition. Other advantages of PACVD method are the high adhesion and the good morphology of the layers [38]. The PACVD process is influenced by several process parameters, like discharge voltage, current density, gas pressure and gas composition and flow rate.

### Improvement of mechanical and tribological properties by PN/PACVD technique

In paper [17] the experimental results indicate that the deposition of a proper duplex PACVD coating and the use of a proper substrate treatment lead to improved tribological properties and a longer lifetime for the hot forging die. In the case of the investigated PACVD TiN-TiB<sub>2</sub> and TiCN coatings the lowest surface roughness and the best coating adhesion were obtained in the case of the polished substrate, with nitriding clearly increasing the hardness and, therefore, the load-carrying capacity of the duplex-treated AISI H11 steel. The microhardness depth distribution for the plasma-nitrided AISI H11 tool steel is shown in Fig. 10. After nitriding at 540°C for 24h the surface hardness of the investigated steel increased to ~ 1350 HV, with a nitriding depth of about 220µm. The TiN-TiB<sub>2</sub> and TiCN coating hardnesses, measured with the nano-indentation method, were found to be ~ 42 and ~ 32GPa, respectively.

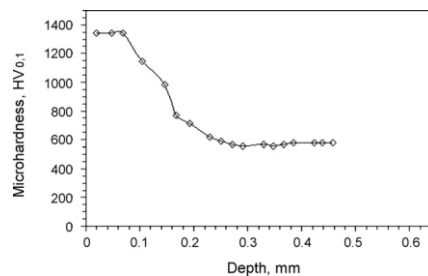


Fig. 10. Microhardness depth distribution for the N specimen [17]

The results of the tribological testing performed on the ball-on-disc tribometer are shown in Fig. 11. Tribologically, the TiCN coating showed a much lower friction and counter-body wear when tested against the hardened 100Cr6 steel, as compared to the TiN-TiB<sub>2</sub> coating. However, when deposited on an as-nitrided substrate the reduced adhesion of the coating led to coating spallation and, consequently, to increased friction and wear. After the industrial test, performed under standard production conditions, the TiCN duplex coated insert (sample N-TiCN) was examined and compared with the standard forging-die insert, which is only nitrided.

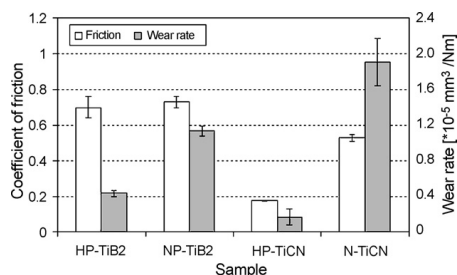


Fig. 11. Average coefficient of friction and steel-ball wear rate for coated specimens. HP-TiB<sub>2</sub> - heat treated+polished; NP-TiB<sub>2</sub> - nitrided+polished; HP-TiCN - heat treated+polished; N-TiCN - as-nitrided [17]

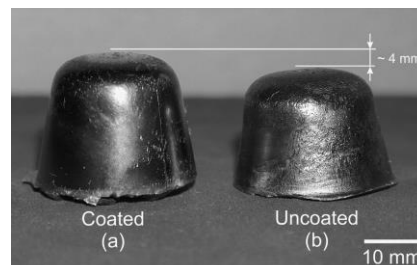
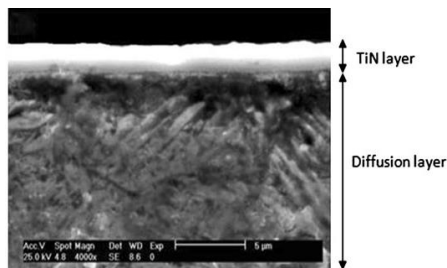


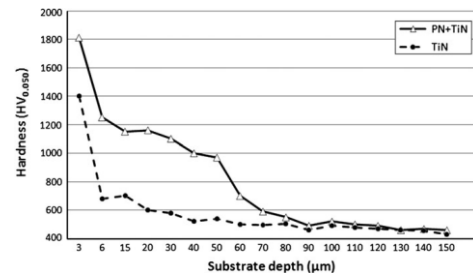
Fig. 12. Forging-die inserts after 13,500 forged parts: (a) TiCN-coated and (b) nitrided insert [17,39]

As shown in Fig. 12, the deposition of gradient or multilayer coatings can significantly improve the wear resistance of hot-forging die inserts. When they are only nitride, the surface hardness of the inserts will drop by more than 15% in less than 15000 strokes, eventually resulting in severe plastic deformation and wear of the inserts. On the other hand, a combination of plasma nitriding and a hard PACVD coating was found to prevent a drop in the surface hardness and almost eliminated the wear of the contact surfaces. As shown in Fig. 12, even after about 15000 strokes the coated inserts were able to maintain their initial geometry.

The aim of study [40] was to investigate the effect of plasma nitriding pre-treatment (PN) on mechanical and tribological behavior of TiN coatings produced by plasma-assisted chemical vapor deposition (PACVD). The heat treatment of quench and temper was carried out on hot work AISI H11 steel samples. Using pre-plasma nitriding can also be useful because deposition of TiN film with the hardness of about 1850 HV on 500 HV hard heat-treated steel forms an unstable and weak interface, due to a high hardness difference between steel substrate and TiN coating in the interface. This problem can be solved by an intermediate layer-like plasma nitrided layer with about 1000 HV hardness to lessen hardness profile gradient and to form CrN phase with the same crystal structure as TiN. The cross section of the TiN film deposited on plasma nitrided steel is given at Fig. 13. The dense microstructure of this coating may lead to better corrosion resistance. Microhardness distributions on the cross section of the samples are presented in Fig. 14.

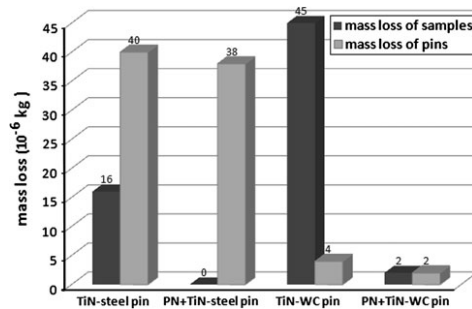


**Fig. 13.** SEM micrographs of the PN+TiN sample: cross section [40]



**Fig. 14.** Microhardness profiles of the TiN coated samples with pre-plasma nitriding (PN+TiN) and without pre-plasma nitriding (TiN) [40]

It is observed that the microhardness profile of sample PN + TiN has lower slope in the interface in comparison to sample TiN which has a more steep change in hardness profile from surface to substrate. Moreover, using plasma nitriding treatment before deposition of TiN coating increases the surface hardness of samples so that the surface hardness of TiN sample is 1400 HV, but PN+TiN sample has 1810 HV surface hardness. Weight loss of the samples and their counter pins after wear tests are presented in Fig. 15. There is a large difference of this parameter for samples TiN and PN+TiN so that the weight loss of sample TiN  $1,6 \times 10^{-5}$  kg against ball-bearing steel pin and is  $4,5 \times 10^{-5}$  kg against WC-Co pin, while for specimen PN+TiN, they are 0 kg and  $2 \times 10^{-6}$  kg. It can be seen that when the specimens were plasma nitrided, their weight loss reduced considerably. The weight loss of sample TiN after wear against steel pin is  $1,6 \times 10^{-5}$  kg, while there is almost no mass loss for sample PN+TiN in this condition. This is due to the weakness of interface between TiN coating and substrate that cause the thin TiN layer to be removed during wear test by crack initiation and its propagation along the interface.



**Fig. 15.** Mass loss of the TiN coated samples with pre-plasma nitriding (PN+TiN) and without pre-plasma nitriding (TiN) and their abrasive pins after pin-on-disk wear test [40]

## CONCLUSION

This paper presents the latest surface engineering procedures based on the combined deposition of double layers with the aim of improving the performance of hot forging tools, which should contribute to increasing service life and quality while reducing operating costs and increasing productivity. The impetus for development research in the field of introduction and application of duplex technologies was given by the complexity of market conditions, ie the need to achieve competitiveness, stability, reduction of total costs and productivity through improving the durability of tools against plastic deformation, abrasive and adhesive wear, thermal and mechanical fatigue and oxidation, which directly leads to an improvement in the quality of the final products obtained by hot forging. Degradation of die material involves a complex interaction of different influential variables, such as die material, construction method, method of production, type of material, pressures and temperatures in the forging process, which mainly leads to recognizable forms of wear that can affect machine downtime, which can lead to increased costs. By using hybrid technologies created by previous plasma nitriding of the surface layer of the die with subsequent deposition of hard antiwear coating using PVD and CVD methods, it is possible to make great savings and make a significant step in reducing wear of key wear components of hot forging machines. Operating parameters in the hot forging process, such as cyclically variable high mechanical loads, intense temperature fluctuations and intense friction can cause local loss and cracking of the coating, ie adhesive wear, intense oxidation, thermal and mechanical fatigue and mild plastic deformation of the substrate at Fe(N) layer. To improve the durability of deposited coatings and layers, pre-treatment with plasma nitriding can be useful, because creating a middle plasma nitrided layer can reduce the large difference in hardness profile between steel substrate and coating, which reduces elastic and plastic deformations of the substrate and provides increased wear resistance and adhesion of the coating, while the coating simultaneously protects the nitrided layer from oxidation and local damage.

## REFERENCES

- [1] Gronostajski, Z., Widomski, P., Kaszuba, M., Zwierzchowski, M., Polak, S., Piechowicz, Ł., Kowalska, J., Długozima, M.: Influence of the phase structure of nitrides and properties of nitrided layerson the durability of tools applied in hot forging processes, *Journal of Manufacturing Processes*, Vol. 52, pp. 247-262, 2020.
- [2] Hawryluk, M., Dobras, D., Kaszuba, M., Widomski, P., Ziemia, J.: Influence of the different variants of the surface treatment on the durability of forging dies made of Unimax steel, *The International Journal of Advanced Manufacturing Technology*, Vol. 107, pp. 4725-4739, 2020.
- [3] Behrens, B.A., Bräuer, G., Paschke, H., Biströn, M.: Reduction of wear at hot forging dies by using coating systems containing boron, *Production Engineering*, Vol. 5, pp. 497-506, 2011.
- [4] Kaszuba, M.: The application of a new, innovative, hybrid technology combining hardfacing and nitriding to increase the durability of forging tools, *Archives of Civil and Mechanical Engineering*, Vol. 20, pp. 1-13, 2020.

- [5] Lavtar, L., Muhič, T., Kugler, G., Terčelj, M.: Analysis of the main types of damage on a pair of industrial dies for hot forging car steering mechanisms, *Engineering Failure Analysis*, Vol. 18, pp. 1143-1152, 2011.
- [6] Kaszuba, M., Widomski, P., Białucki, P., Lange, A., Boryczko, B., Walczak, M.: Properties of new-generation hybrid layers combining hardfacing and nitriding dedicated to improvement in forging tools' durability, *Archives of Civil and Mechanical Engineering*, Vol. 20, pp. 1-12, 2020.
- [7] Smolik, J.A.: Hybrid surface treatment technology for increase of hot forging dies, *Archives of Metallurgy and Materials*, Vol. 57, pp. 657-664, 2012.
- [8] Bayramoglu, M., Polat, H., Geren, N.: Cost and performance evaluation of different surface treated dies for hot forging process, *Journal of Materials Processing Technology*, Vol. 205, pp. 394-403, 2008.
- [9] Das, K., Alphonsa, J., Ghosh, M., Ghanshyam, J., Rane, R., Mukherjee, S.: Influence of pretreatment on surface behavior of duplex plasma treated AISI H13 tool steel, *Surfaces and Interfaces*, Vol. 8, pp. 206-213, 2017.
- [10] Podgrajšek, M., Glodež, S., Ren, Z.: Failure analysis of forging die insert protected with diffusion layer and PVD coating, *Surface and Coatings Technology*, Vol. 276, pp. 521-528, 2015.
- [11] Widomski, P., Gronostajski, Z.: Comprehensive Review of Methods for Increasing the Durability of Hot Forging Tools, *Procedia Manufacturing*, Vol. 47, pp. 349-355, 2020.
- [12] Stupnišek, M., Matijević, B.: Pregled postupaka modificiranja i prevlačenja metala, *Zbornik radova znanstveno stručnog skupa s međunarodnim učešćem Toplinska obradba metala i inženjerstvo površina*, pp. 53-62, Hrvatska, Zagreb, 2000.
- [13] Gavalas, E., Rossbach, A., Feuerhack, A.: Performance analysis of laser-treated hot forging dies with WC-Co-Cr, *The International Journal of Advanced Manufacturing Technology*, Vol. 106, pp. 1327-1336, 2020.
- [14] Devi, M.U.: Damage Mechanisms in Salt Bath Nitro-carburised and Plasma Nitrided Hot Forging Dies of H11 Tool Steel, *ISIJ International*, Vol. 42, pp. 527-533, 2002.
- [15] Castro, G., Fernández-Vicente, A., Cid, J.: Influence of the nitriding time in the wear behaviour of an AISI H13 steel during a crankshaft forging process, *Wear*, Vol. 263, pp. 1375-1385, 2007.
- [16] Behrens, A.B., Bouguecha, A., Huskic, A., Baumer, M., Paschke, H., Lippold, L.: Increasing the Efficiency of Forging Operations Using Adjusted Tribological Surfaces Enhanced by Hard Coatings, *Tribology Online*, Vol. 11, pp. 432-443, 2016.
- [17] Leskovšek, V., Podgornik, B., Jenko, M.: A PACVD duplex coating for hot-forging applications, *Wear*, Vol. 266, pp. 453-460, 2009.
- [18] Behrens, B.A., Yilkiran, T., Braeuer, G., Paschke, H., Weber, M.: Potential of Duplex Plasma Deposition Processes for the Improvement of Wear Resistance of Hot Forging Dies, *Key Engineering Materials*, Vol. 554-557, pp. 345-358, 2013.
- [19] Podgornik, B., Leskovšek, V., Tehovnik, F., Burja, J.: Vacuum heat treatment optimization for improved load carrying capacity and wear properties of surface engineered hot work tool steel, *Surface and Coatings Technology*, Vol. 261, pp. 253-261, 2015.
- [20] Yilkiran, T., Behrens, B., Paschke, H., Weber, M., Brand, H.: The potential of plasma deposition techniques in the application field of forging processes, *Archives of Civil and Mechanical Engineering*, Vol. 12, pp. 284-291, 2012.
- [21] Ebara, R., Kubota, K.: Failure analysis of hot forging dies for automotive components, *Engineering Failure Analysis*, Vol. 15, pp. 881-893, 2008.
- [22] Buchmayr, B.: Damage, Lifetime, and Repair of Forging Dies, *BHM Berg- und Hüttenmännische Monatshefte*, Vol. 162, pp. 88-93, 2017.
- [23] Terčelj, M., Panjan, P., Urankar, I., Fajfar, P., Turk, R.: A newly designed laboratory hot forging test for evaluation of coated tool wear resistance, *Surface & Coatings Technology*, Vol. 200, pp. 3594-3604, 2006.
- [24] Gronostajski, Z., Kaszuba, M., Widomski, P., Smolik, J., Ziemba, J., Hawryluk, M.: Analysis of wear mechanisms of hot forging tools protected with hybrid layers performed by nitriding and PVD coatings deposition, *Wear*, Vol. 420-421, pp. 269-280, 2019.

- [25] Quesada, F., Mariño, A., Restrepo, E.: TiAlN coatings deposited by r.f. magnetron sputtering on previously treated ASTM A36 steel, *Surface & Coatings Technology*, Vol. 201, pp. 2925-2929, 2006.
- [26] Karlsson, L., Hultman, L., Sundgren, J-E.: Influence of residual stresses on the mechanical properties of  $TiC_xN_{1-x}$  (0,015, 0,45) thin films deposited by arc evaporation, *Thin Solid Films*, Vol. 371, pp. 167-177, 2000.
- [27] Fuentes, G.G., Cáceres, D., Vergara, I., Elizalde, E., Sanz, J.M.: Elastic properties of hard  $TiC_xN_y$  films grown by dual ion beam sputtering, *Surface and Coatings Technology*, Vol. 151-12, pp. 365-369, 2002. Recco André Candido, A., Tschiptschin Paulo, A., Structural and Mechanical Characterization of Duplex Multilayer Coatings Deposited onto H13 Tool Steel, *Journal of Materials Research and Technology*, Vol. 1, pp. 182-188, 2012.
- [28] Bahrens, A.B., Bach, W.F., Moehwald, K., Deißer, A.T., Biströn, M.: Use of a TiBN Multilayer Coating for Wear Reduction, *AIP Conference Proceedings*, pp. 1047-1052, Portugal, Porto, 2007.
- [29] Tillmann, W., Vogli, E., Momeni, S.: Mechanical and tribological properties of Ti/TiAlN duplex coatings on high and low alloy tool steels, *Vacuum*, Vol. 84, pp. 387-392, 2010.
- [30] Panjan, P., Urankar, I., Navinšek, B., Terčelj, M., Turk, R., Čekada, M., Leskovšek, V.: Improvement of hot forging tools with duplex treatment, *Surface and Coatings Technology*, Vol. 151-152, pp. 505-509, 2002.
- [31] Smolik, J.: The influence of thickness of CrN coating on the durability of hot forging dies, *Central European Journal of Engineering*, Vol. 1, pp. 210-216, 2011.
- [32] Navinšek, B., Panjan, P., Urankar, I., Cvahte, P., Gorenjak, F.: Improvement of hot-working processes with PVD coatings and duplex treatment, *Surface and Coatings Technology*, Vol. 142-144, 1148-1154, 2001.
- [33] Lee, S.: Mechanical properties of  $TiN_x/Cr_{1-x}N$  thin films on plasma nitriding-assisted AISI H13 steel, *Surface & Coatings Technology*, Vol. 193, pp. 55-59, 2005.
- [34] Raoufi, M., Mirdamadi, Sh., Mahboubi, F., Ahangarani, Sh., Mahdipoor, M.S., Elmkhah, H.: Effect of active screen plasma nitriding pretreatment on wear behavior of TiN coating deposited by PACVD technique, *Applied Surface Science*, Vol. 258, pp. 7820-7825, 2012.
- [35] Sörensen, F.P., Cisló, C., Paschke, H., Stockinger, M., Engel, B.: Dry friction under pressure variation of PACVD TiN surfaces on selected automotive sheet metals for the application in unlubricated metal forming, *Wear*, Vol. 476, pp. 1-9, 2021.
- [36] Mitterer, C., Holler, F., Reitberger, D., Badisch, E., Stoiber, M., Lugmair, C., Nöbauer, R., Müller, Th., Kullmer, R.: Industrial applications of PACVD hard coatings, *Surface and Coatings Technology*, Vol. 163-164, pp. 716-722, 2003.
- [37] Shafiei, S.M.M., Divandari, M., Boutorabi, S.M.A., Naghizadeh, R.: Effects of the gas mixture on the characteristics of PACVD TiN coating of hot-work tool steel, *Journal of Ceramic Processing Research*, Vol. 15, pp. 308-311, 2014.
- [38] Podgornik, B., Leskovšek, V.: Wear mechanisms and surface engineering of forming tools, *Materials and technology*, Vol. 49, pp. 313-324, 2015.
- [39] Mahdipoor, S.M., Mahboubi, F., Ahangarani, Sh., Raoufi, M., Elmkhah, H.: The Influence of Plasma Nitriding Pre-Treatment on Tribological Properties of TiN Coatings Deposited by PACVD, *Journal of Materials Engineering and Performance*, Vol. 21, pp. 958-964, 2012.

## APPLICATION OF ISO – IEC 80000-6:2008 IN THE DESCRIPTION OF TECHNICAL SYSTEMS

**Domagoj Pejakušić, Yvonne Liermann-Zeljak, Hrvoje Glavaš**

University of Osijek, Faculty of Electrical Engineering, Computer Science and Information  
Technology Osijek, Osijek, Croatia  
e-mail: [hrvoje.glavas@ferit.hr](mailto:hrvoje.glavas@ferit.hr)

**Abstract:** Systems that perform a function are often referred to as technical systems. A technical system can consist of one or more subsystems. Technical systems are described using numbers, units and mathematical expressions. A special form of notation is dedicated to systems based on the laws of physics encompassed under the name Electromagnetism. The number of scientists for whom physics is not the primary profession and who study electromagnetism is constantly growing. Therefore, an unambiguous way of writing in accordance with the standards is extremely important. The international standard that defines Electromagnetism is ISO - IEC 80000-6: 2008 Quantities and units - Part 6: Electromagnetism. The International Organization for Standardization, in cooperation with the International Electrotechnical Commission (IEC), enacts the above standard, which introduces order in the way of writing: names, symbols, and definitions for quantities and units of electromagnetism. The paper gives a brief overview of the role of ISO in Sustainable Development Goals. Furthermore, it provides an overview of all parts of ISO 80000 with special reference to IEC 80000-6: 2008 recommendations. In order to analyse the applicability of the standard, an analysis of published articles in five scientific journals during an arbitrarily selected year was performed. The numerical indicators of published papers, the average number of pages per paper and the percentage of elements in the papers for each of the journals are graphically presented. Finally, an assessment of the correct application of the standard in the respective journals was carried out.

**Key words:** standard, ISO, IEC 80000-6:2008, electromagnetism, technical systems

### INTRODUCTION

A technical system is every system that performs a function. Examples of technical systems include cars, pens, books and knives. Any technical system can consist of one or more subsystems. A car is composed of the subsystems engine, steering mechanism, brakes, etc. Each of these is also a technical system unto itself (with its own series of subsystems) — and each performs its own function. The hierarchy of technical systems spans from the least complex, with only two elements, to the most complex with many interacting elements, [1]. A description of a technical system is inconceivable without numbers. In 1883, Lord Kelvin said: “I often say that when you can measure what you are speaking about, and express it in numbers, you know something about it; but when you cannot measure it when you cannot express it in numbers, your knowledge is of a meagre and unsatisfactory kind; it may be the beginning of knowledge, but you have scarcely in your thoughts advanced to the state of Science, whatever the matter may be.”, [2]. Pythagoras assured his followers: Everything is a number. They coined the word *philosophy* as well as the word *mathematikoi* which means “erudite people” and from which the word “mathematics” was derived, [3]. Mathematics, as an essential tool for physics, is used for the description of Electromagnetism, a branch of physics that analyses the interaction among electric charges, magnetic moments and the electromagnetic field. The number of scientists for whom physics is not the primary profession and who study electromagnetism is constantly growing. The way of writing particular terms is often not in line with the standards. Therefore, the standard-related recommendations are of utmost importance. The international standard that defines Electromagnetism is ISO - IEC 80000-6: 2008 Quantities and units - Part 6: Electromagnetism, [4]. This paper gives an overview of the guidelines recommended by the standard and the application of these guidelines by analysing five scientific journals.

### STANDARDS AND STANDARDIZATION

Standardization is the activity of establishing an optimum degree of order for common and repeated use in a given context with regard to potential problems or actual problems, [5]. A standard is a



document adopted and agreed by consensus and approved by a recognized body. It is intended especially for repeated use because it gives guidelines, rules and describes activities with the aim of optimizing the process, [5]. The function of a standard is to efficiently connect systems, provide quality of service and reduce a variety of different systems and describe processes and products. Standards can be divided into formal (DIN, CEN), informal (IEEE, VDI) and private, [6]. One of the most important institutions is the International Organization for Standardization (ISO). With respect to sustainability, ISO has set 17 Sustainable Development Goals, Table 1.

**Table 1. ISO Sustainable Development Goals, [7]**

No. of norms	Goal
340	No poverty - end poverty in all its forms everywhere
529	Zero hunger - end hunger, achieve food security and improved nutrition and promote sustainable agriculture
2768	Good health and well-being - ensure healthy lives and promote well-being for all at all ages
476	Quality education - ensure inclusive and equitable quality education and promote lifelong learning opportunities for all
176	Gender equality - achieve gender equality and empower all women and girls
539	Clean water and sanitation - ensure availability and sustainable management of water and sanitation for all
815	Affordable and clean energy - ensure access to affordable, reliable, sustainable and modern energy for all
2394	Decent work and economic growth - promote sustained, inclusive and sustainable economic growth, full and productive employment and decent work for all
12461	Industry, innovation and infrastructure - build resilient infrastructure, promote inclusive and sustainable industrialization and foster innovation
499	Reduced inequalities - reduce inequality within and among countries
2304	Sustainable cities and communities - make cities and human settlements inclusive, safe, resilient and sustainable
2528	Responsible consumption and production - ensure sustainable consumption and production patterns
1067	Climate action - take urgent action to combat climate change and its impacts
273	Life below water - conserve and sustainably use the oceans, seas and marine resources for sustainable development
1036	Life on land - protect, restore and promote sustainable use of terrestrial ecosystems, sustainably manage forests, combat desertification, and halt and reverse land degradation and halt biodiversity loss
154	Peace, justice and strong institutions - promote peaceful and inclusive societies for sustainable development, provide access to justice for all and build effective, accountable and inclusive institutions at all levels
	Partnerships for the goals - strengthen the means of implementation and revitalize the global partnership for sustainable development
340	No poverty - end poverty in all its forms everywhere

Table 1 describes ISO goals with respect to sustainable development and the number of standards which can be related to individual areas. ISO has developed over 23919 International Standards and all are included in the ISO Standards catalogue. The number of standards from 1996 to 2018 is shown in Figure 1, [8].

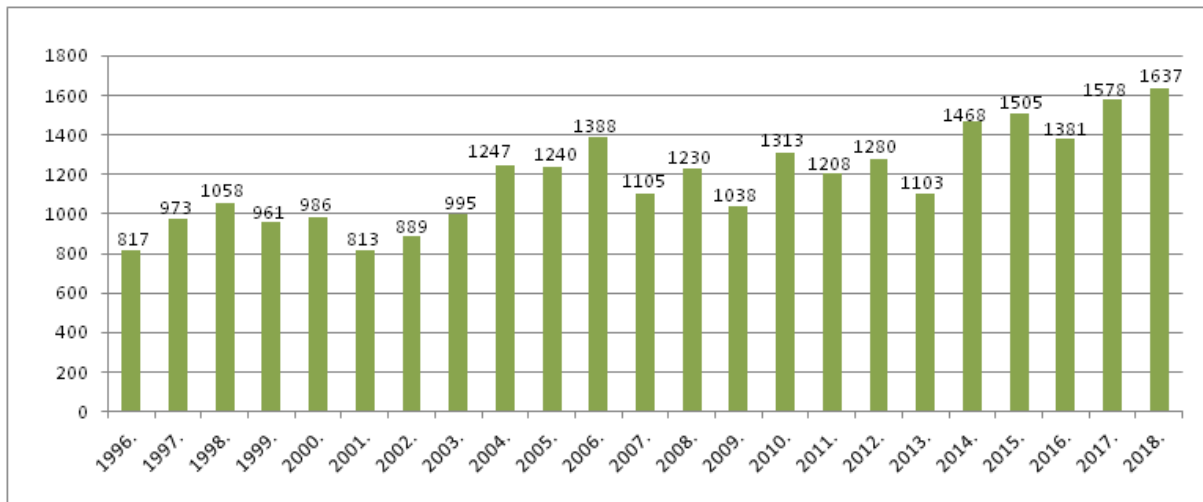


Fig. 1. The number of newly published ISO standards by year, [8]

Technical systems are mainly based on Electromagnetism and mathematical models that need to be described in the documentation, which in part translates into instructions for use, maintenance instructions and service instructions. In the field of defining standards which are used to define the correct writing of the description of technical systems, ISO, in cooperation with the International Electrotechnical Commission (IEC), issued the ISO 80000 standard, which consists of 14 parts, [9]. The ISO 80000 series of standards was published from 2007 to 2011. The IEC played the leading role in the development of parts 6, 13 and 14, and ISO in the others. The first page of the printed editions contains the logos of both international organizations; however, the logo of the organization that played the leading role in developing that particular standard appears in the first position. The European Committee for Standardization (CEN) and the European Committee for Electrotechnical Standardization (CENELEC) have accepted and published only some of the ISO 80000 series of standards. CEN and CENELEC published Part 8 and Parts 6, 13, 14, respectively, [9]. Individual standards designation and scope of application are:

ISO 80000-1:2009	Quantities and units – Part 1: General
ISO 80000-2:2009	Quantities and units -- Part 2: Mathematical signs and symbols to be used in the natural sciences and technology
ISO 80000-3:2006	Quantities and units -- Part 3: Space and time
ISO 80000-4:2006	Quantities and units -- Part 4: Mechanics
ISO 80000-5:2007	Quantities and units -- Part 5: Thermodynamics
EN 80000-6:2008	Quantities and units -- Part 6: Electromagnetism
ISO 80000-7:2008	Quantities and units -- Part 7: Light
EN ISO 80000-8:2007	Quantities and units -- Part 8: Acoustics
ISO 80000-9:2009	Quantities and units -- Part 9: Physical chemistry and molecular physics
ISO 80000-10:2009	Quantities and units -- Part 10: Atomic and nuclear physics
ISO 80000-11:2008	Quantities and units -- Part 11: Characteristic numbers
ISO 80000-12:2009	Quantities and units -- Part 12: Solid state physics
EN 80000-13:2008	Quantities and units -- Part 13: Information science and technology
EN 80000-14:2009	Quantities and units -- Part 14: Telebiometrics related to human physiology

#### SCOPE OF APPLICATION OF IEC 80000-6:2008

Scope of IEC 80000-6:2008 encompasses names, symbols, and definitions for quantities and units of electromagnetism. It also provides insight into conversion factors. The International Standard IEC 80000-6 has been prepared by IEC Technical Committee 25: Quantities and Units, and their letter symbols in close cooperation with ISO/TC 12, quantities, units, symbols, conversion factors. IEC 80000-6 cancels and replaces the second edition of ISO 31-5, published in 1992, and its amendment 1 (1998). The standard is based on the SI System of Units, as acknowledged and reflected in the

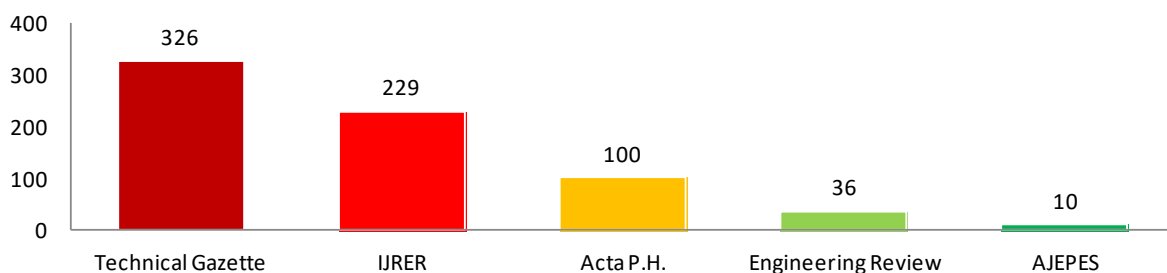
standards of ISO and IEC. The SI has seven base units, among them metre, symbol m, kilogram, symbol kg, second, symbol s, and ampere, symbol A. For quantities that vary sinusoidally with time, and for their complex representations, the IEC has standardized two ways to build symbols. Capital and lowercase letters are generally used for electric current and voltage, and additional marks for other quantities. An example of quantities described in the standard is shown in Table 2.

**Table 2.** An example of quantities as described by IEC 80000-6:2008

Name	Symbol	Definition and Remarks
Poynting vector	$\mathbf{S}$	$\mathbf{S} = \mathbf{E} \times \mathbf{H}$ where $\mathbf{E}$ is the electric field strength and $\mathbf{H}$ is the magnetic field strength
source voltage, source tension	$U_s$	The voltage between the two terminals of a voltage source when there is no electric current through the source. The name "electromotive force" with the abbreviation EMF and the symbol $\mathcal{E}$ is deprecated.
apparent power	$ S $	$ S  = UI$ where $U$ is the rms value of voltage and $I$ is the rms value of electric current $U = \sqrt{\frac{1}{T} \int_0^T u^2 dt} \quad I = \sqrt{\frac{1}{T} \int_0^T i^2 dt}$
power factor	$\lambda$	$\lambda = P/ S $ where $P$ is the active power and $S$ is the apparent power.

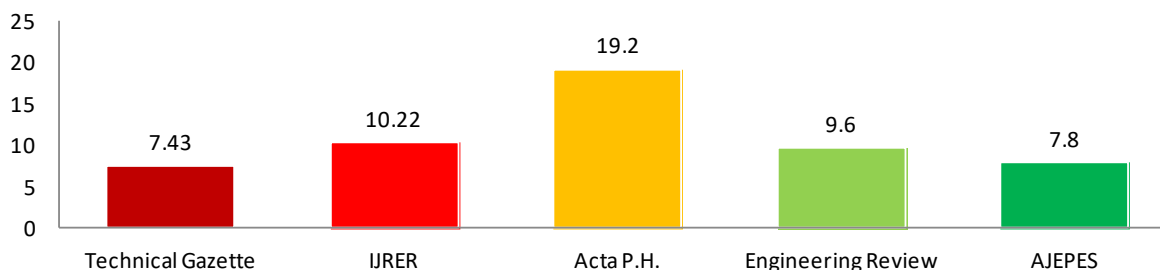
## ANALYSIS OF THE APPLICATION OF IEC 80000-6:2008 IN SCIENTIFIC AND TECHNICAL JOURNALS

Standards exist to bring order in a particular field and provide unambiguous designation. The best way to present an analysis of the application of IEC 80000-6:2008 is using examples from scientific journals which keep the highest standards with respect to the presentation of scientific papers. In accordance with previous research on ISO 8000 applicability described in the final paper [8], the same journals in which the analysis of the standard ISO 80000-2:2009 applicability which deals with mathematical texts were selected. The analysis of the application of IEC 80000-6:2008 was carried out in papers published in 2018 in the following journals: Tehnički vjesnik/Technical Gazette ISSN 1330-3651, [10]; Engineering Review, ISSN 1330-9587, [11]; Acta Polytechnica Hungarica ISSN 1785-8860, [12]; American Journal of Electrical Power and Energy Systems ISSN: 2326-912X, [13] and International Journal of Renewable Energy Research ISSN: 1309-012, [14]. The analysis was performed by the first author as part of the final paper written at the Faculty of Electrical Engineering, Computer Science and Information Technology Osijek, [15]. The total number of analysed papers was 701; however, the conducted analysis is a subjective review and despite careful analysis, there is a possibility of deviation from the actual situation. The number of published articles during the year differs significantly for each journal, Figure 2.



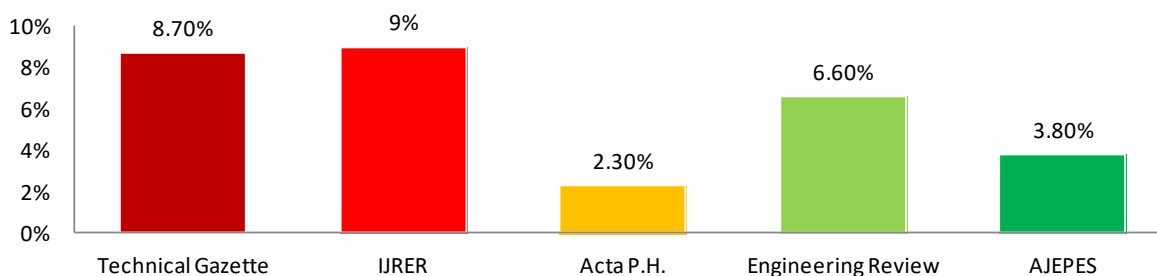
**Fig. 2.** Number of published scientific papers in the journal per year

On average, Tehnički vjesnik/Technical Gazette publishes 40 articles per issue which results in a high number in Fig.2. The International Journal of Renewable Energy Research is quarterly published with an average of 57 articles per issue. Acta Polytechnica Hungarica published 8 issues per year and has an average of 12 papers. Engineering Review is published in three issues with an average number of 12 papers per issue. In 2018 American Journal of Electrical Power and Energy Systems published six issues with two papers per issue. The number of pages per paper also differs which is shown in Fig. 3



**Fig. 3.** Number of pages per scientific papers

A significant number of pages per paper can be visible in Acta Polytechnica Hungarica which is due to the one-column format, while other journals use the two-column format. The share of the text related to Electromagnetism and subject to the guidelines of the sixth part of the standard, in all papers published in 2018, is shown in Figure 4.



**Fig. 4.** Share of the text subject to IEC 80000-6:2008 guidelines

The frequency of text deviates considerably compared to the average of the two journals Acta Polytechnica Hungarica and American Journal of Electrical Power and Energy Systems. Deviation from the average only shows the frequency of the topics which deal with Electromagnetism, whereas Table 3 presents compliance with the standard with respect to deviation from standard recommendations. In other words, in Table 3 a classification of application of the standard in individual journals using grades from 1 to 5 was conducted.

**Table 3.** Evaluation of the application of IEC 80000-6:2009

Journal	Grade
Tehnički vjesnik/Technical Gazette	5
Engineering Review	3
Acta Polytechnica Hungarica	4
American Journal of Electrical Power and Energy Systems	4
International Journal of Renewable Energy Research	4

## CONCLUSION

Systems that perform a function are often referred to as technical systems. A description of a technical system is inconceivable without numbers and symbols. Most technical systems include phenomena that we encompass under the name Electromagnetism. The number of scientists for whom physics is not the primary profession and who study electromagnetism is constantly growing. Therefore, an

unambiguous way of writing complying with the standards recommendations is extremely important. The international standard that defines Electromagnetism is ISO - IEC 80000-6: 2008 Quantities and units - Part 6: Electromagnetism. The International Organization for Standardization, in cooperation with the International Electrotechnical Commission (IEC), enacts the above standard, which introduces order in the way of writing: names, symbols, and definitions for quantities and units of electromagnetism. The IEC 80000-6: 2008 provides examples of records of all sizes describing the field of Electromagnetism through name, symbol, definition and notes. The rules that are used in the standardisation system allow only for a brief overview on the examples of quantities described by the standard. From a handful of examples, we opted for the Poynting vector which describes the direction of energy movement, voltage source, apparent power and power factor. The application of the standard is shown on the example of five international scientific journals. The practical analysis was performed by the first author as part of the final paper and about 700 scientific papers were analysed. Taking the above into account, the conducted analysis is a subjective review and despite careful analysis, there is a possibility of deviation from the actual situation. The results of the analysis presented graphically indicate that the elements in the articles related to the standard are represented on average by 6%. The average applicability of the standard is up to 75%, and Technical Gazette is an example of full compliance with the standard recommendations.

## REFERENCES

- [1] Technical Innovation Center, Inc. <https://www.triz.org/triz/technical-systems>, (Access: 30 April 2021)
- [2] Lord Kelvin quote on measurement <https://www.atmos.washington.edu/~robwood/teaching/451/resources.html>, (Access: 30 April 2021)
- [3] Darko Veljan Čarobne četvorine (iliti magični kvadrati) Poučak : časopis za metodiku i nastavu matematike, Vol. 15 No. 57, 2014.
- [4] IEC 80000-6:2008 Quantities and units — Part 6: Electromagnetism <https://www.iso.org/standard/31891.html>, (Access: 30 April 2021)
- [5] ISO/IEC Guide 2:2004 Standardization and related activities -- General vocabulary
- [6] H. Glavaš, F. Zovko-Ribić, D. Dorić and D. Talapko, "Development of Energy Management Standards" 2018 International Conference on Smart Systems and Technologies (SST), 2018, pp. 185-189, doi: 10.1109/SST.2018.8564633.
- [7] Sustainable Development Goals <https://www.iso.org/sdgs.html>
- [8] Damjan Cvenić, Application of ISO 80000-2:2009 in the description of technical systems, graduate thesis, Faculty of Electrical Engineering, Computer Science and Information Technology Osijek, Josip Juraj Strossmayer University Of Osijek, 2019.
- [9] Tanatarec, Biljana; Nikolić, Nenad, "Novi niz normi mjernih jedinica i veličina ISO 80000" Zbornik radova - Četvrto savjetovanje: Iskustva laboratorija u primjeni HRN EN ISO/IEC 17025 Zagreb: Hrvatsko mjeriteljsko društvo, 2012. str. 1-4
- [10] TECHNICAL GAZETTE <https://hrcak.srce.hr/tehnicki-vjesnik>, (Access: 30 April 2021)
- [11] Engineering Review <https://hrcak.srce.hr/engineering-review>, (Access: 30 April 2021)
- [12] Acta Polytechnica Hungarica <http://acta.uni-obuda.hu>, (Access: 30 April 2021)
- [13] American Journal of Electrical Power and Energy Systems <http://www.ajepes.org/index>, (Access: 30 April 2021)
- [14] International Journal of Renewable Energy Research <https://www.ijrer.org/ijrer/index.php/ijrer>, (Access: 30 April 2021)
- [15] Domagoj Pejakušić, Application of ISO 80000-6:2009 in the description of technical systems, graduate thesis, Faculty of Electrical Engineering, Computer Science and Information Technology Osijek, Josip Juraj Strossmayer University of Osijek, 2021.

## DETERMINATION OF NATURAL FREQUENCY AND AMPLITUDE RATIO OF A RAYLEIGH DOUBLE BEAM SYSTEM WITH A KEER MIDDLE LAYER SUBJECTED TO COMPRESSIVE AXIAL LOAD

Branislav Milenković<sup>1</sup>, Danilo Karličić<sup>1</sup>, Đorđe Jovanović<sup>1</sup>

<sup>1</sup>Mathematical Institute of Serbian Academy of Science and Arts, Belgrade, Serbia

e-mail: [bmilenkovic92@gmail.com](mailto:bmilenkovic92@gmail.com)

**Abstract:** Free transverse vibration of a Rayleigh double-beam system with effect of compressive axial load with a Keer layer in-between are studied in this paper. It is assumed that the two beams of the system are continuously joined by a Keer layer. The equations of motion for this system are described by a set of three homogenous differential equations. The classic Bernoulli-Fourier method was used for solving this system of differential equations. In the research found in literature on the subject of Kerr model, the most common methods used are theories of Timoshenko and Euler-Bernoulli. It is for that exact reason that the research goal of this paper is determining analytical and numerical characteristics (natural frequency and associated amplitude ratio) of the considered model by applying the Rayleigh theory. The numerical results obtained are shown in the form of a plot diagram. Presented numerical results in this paper confirm those obtained in the literature.

**Key words:** natural frequency, amplitude ratio, Keer layer, Rayleigh double beam

### INTRODUCTION

A large number of mechanical systems is of complex structure composed of two or more basic mechanical systems, whose dynamic behavior is conditioned by their mutual interaction. Systems connected by an elastic layer compose a group of such mechanical structures, and they have wide appliance in mechanical and civil industry. Oscillations and stability of such systems are the subject of scientific and practical work spanning several decades.

Oniszczyk [1,2] analyzed the problem of free and forced oscillations of two elastically bound Euler-Bernoulli carriers. The paper determines analytical solutions of eigen frequencies for amplitude functions and oscillation forms. In the paper by Zhang et al. [3], on the basis of the Bernoulli-Euler beam theory, the properties of free transverse vibration and buckling of a double beam system under compressive axial loading are investigated. It is found that the effects of compressive axial loading on the natural frequencies of the system and associated amplitude ratios are more significant with the increase of axial compression. Also, the effects of compressive axial loading on the higher natural frequency and the amplitude ratios are significantly dependent on the axial compression ratio whereas that on the lower natural frequency is almost independent of it. It is concluded that the critical buckling load gets smaller with the increase of the ratio of the axial load  $F_2$  to  $F_1$  and the diminishment of the stiffness modulus  $K$  of the Winkler elastic layer.

In paper by Stojanovic et al.[4], free transverse vibration and buckling of a double-beam continuously joined by a Winkler elastic layer under compressive axial loading with the influence of rotary inertia and shear are considered. The motion of the system is described by a homogeneous set of two partial differential equations, which is solved by using the classical Bernoulli-Fourier method. A structural model of a layered-beam system composed of two parallel Euler beams of uniform properties axially loaded with a flexible Winkler elastic layer in-between was used to study all the desired effects. It is determined that the influence of rotary inertia and shear on natural frequencies is manifested by the reduction of their values. In addition, it is found that the rotary inertia does not influence the critical buckling load model of a layered-beam system composed of two parallel Rayleigh beams, yet when the model of a layered-beam system composed of two parallel Timoshenko beams is considered, the influence of transverse shear causes a decrease in the critical buckling load.

Paper by Kozic et al. [5], an analytical theory to define the dynamic characteristics of the elastically connected parallel-beams under compressive axial loading. It is assumed that the two parallel-beams of the system are simply supported and continuously joined by a Kerr-type three parameter model. The

motion of the system is described by a set of three homogeneous partial differential equations, which are solved by using the classical Bernoulli–Fourier method. The natural frequencies, associated amplitude ratio and the critical buckling load for complex system are determined. The model is tested numerically, and the results were compared with other numerical models.

In the paper by Mohammadi and Nasirshoabi [6], the forced transverse vibrations of an elastically connected simply supported double-beam system with a Pasternak middle layer subjected to compressive axial load are investigated using the Rayleigh beam theory. The properties of the forced transverse vibrations of the system are found to be significantly dependent on the compressive axial load and shear foundation modulus of Pasternak layer. The axial compression and shear foundation modulus of the Pasternak layer affects the magnitudes of the steady-state vibration amplitudes of the beam. Also, the ratios ( $\varphi_1$ ) and ( $\varphi_2$ ) decrease with increasing of the shear foundation modulus of Pasternak layer  $G_0$ . This research can be used in optimal design of a dynamic rotation absorber.

This paper is organized as follows. In Section 2 mathematical model of double beam system with Keer layer in between was formed using Rayleigh beam theory [7,8]. In Section 3 we solved formed differential equations in previous section and obtained analytical expressions of natural frequency and associated amplitude ratio. In Section 4, the numerical analysis of the system was performed using Matlab R2019a. Finally, in section 5, the conclusions are drawn, briefly.

## MATHEMATICAL MODEL

Fig. 1 shows double-beam system with Keer layer [9] in-between with length of  $l$  subjected to axial compressions  $F_1$  and  $F_2$ . The model assumes that the axial forces  $F_1$  and  $F_2$  are not changed with time, the two beams have the same effective material constants, the rotary inertia and shear deformation are negligible, the behavior of the beam material is linear elastic and the cross-section is rigid and constant throughout the length of the beam and has one plane of symmetry.

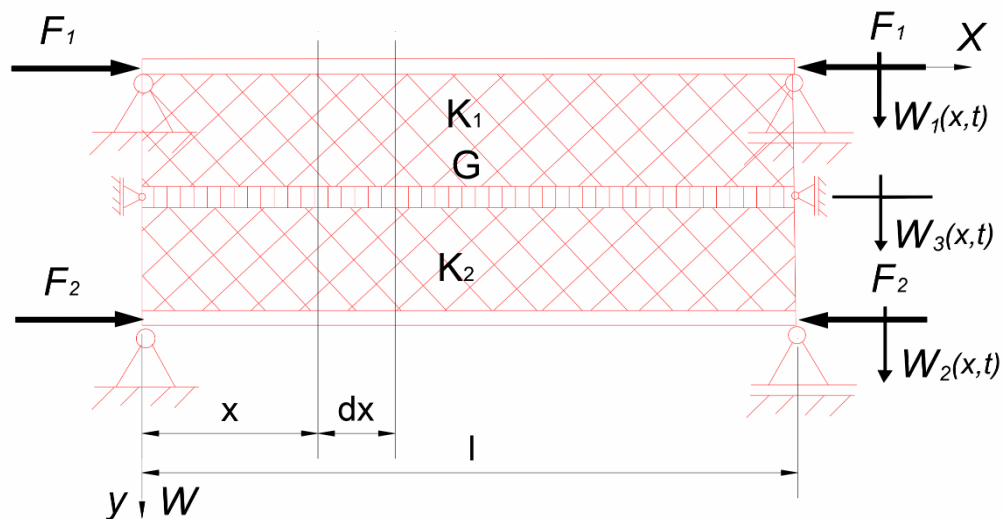


Fig. 1. Double-beam dynamic system with a Kerr middle layer

The equations of free transverse vibration of a Rayleigh double-beam system with the effect of compressive axial load with a Kerr layer in-between have the following form:

$$\rho A_1 \frac{\partial^4 w_1}{\partial t^2} - \rho I_1 \frac{\partial^4 w_1}{\partial x^2 \partial t^2} + EI_1 \frac{\partial^4 w_1}{\partial x^4} + F_1 \frac{\partial^2 w_1}{\partial x^2} + K_1 (w_1 - w_3) = 0 \quad (1)$$

$$G \frac{\partial^2 w_3}{\partial x^2} - (K_1 + K_2) w_3 + K_1 w_1 + K_2 w_2 = 0 \quad (2)$$

$$\rho A_2 \frac{\partial^4 w_2}{\partial t^2} - \rho I_2 \frac{\partial^4 w_2}{\partial x^2 \partial t^2} + EI_2 \frac{\partial^4 w_2}{\partial x^4} + F_2 \frac{\partial^2 w_2}{\partial x^2} + K_2 (w_3 - w_2) = 0 \quad (3)$$

where  $\rho$  is the mass density,  $A$  is the cross-sectional area of the beam,  $I_x$  is the moment of inertia of the beam cross-section and  $E$  Young's modulus.

Eliminating  $w_3$  from equations (1) and (3) one can obtain two sixth order coupled governing differential equations:

$$\begin{aligned} \frac{GEI_1}{K_1} \frac{\partial^6 w_1}{\partial x^6} - \frac{G\rho I_1}{K_1} \frac{\partial^6 w_1}{\partial x^4 \partial t^2} + \left[ \frac{GF_1}{K_1} - EI_1 \left( 1 + \frac{K_2}{K_1} \right) \right] \frac{\partial^4 w_1}{\partial x^4} + \frac{G\rho A_1}{K_1} \frac{\partial^4 w_1}{\partial x^2 \partial t^2} + \left[ G - F_1 \left( 1 + \frac{K_2}{K_1} \right) \right] \frac{\partial^2 w_1}{\partial x^2} \\ - \rho A_1 \left( 1 + \frac{K_2}{K_1} \right) \frac{\partial^2 w_1}{\partial t^2} - K_2 w_1 + K_2 w_2 = 0 \end{aligned} \quad (4)$$

$$\begin{aligned} \frac{GEI_2}{K_2} \frac{\partial^6 w_2}{\partial x^6} - \frac{G\rho I_2}{K_2} \frac{\partial^6 w_2}{\partial x^4 \partial t^2} + \left[ \frac{GF_2}{K_2} - EI_2 \left( 1 + \frac{K_2}{K_1} \right) \right] \frac{\partial^4 w_2}{\partial x^4} + \frac{G\rho A_2}{K_2} \frac{\partial^4 w_2}{\partial x^2 \partial t^2} + \left[ G - F_2 \left( 1 + \frac{K_2}{K_1} \right) \right] \frac{\partial^2 w_2}{\partial x^2} \\ - \rho A_2 \left( 1 + \frac{K_2}{K_1} \right) \frac{\partial^2 w_2}{\partial t^2} - K_1 w_2 + K_1 w_1 = 0 \end{aligned} \quad (5)$$

The initial conditions in general form and boundary conditions for simply supported beams of the same length are assumed as follows:

$$w_i(x, 0) = w_{i0}(x), \quad \dot{w}_i(x, 0) = v_{i0}(x), \quad (6)$$

$$w_i''(0, t) = w_i(0, t) = w_i(l, t) = w_i''(l, t), \quad i = 1, 2. \quad (7)$$

## SOLUTION OF THE PROBLEM

Assuming time harmonic motion and using separation of variables, the solutions to Eqs. (3) and (4) with the governing boundary conditions can be written in the form:

$$w_i(x, t) = \sum_{n=1}^{\infty} X_n(x) T_{ni}(t), \quad (8)$$

where  $T_{in}(t)$  denote the unknown functions, and  $X_n(x)$  is the known mode shape function which is defined as:

$$X_n(x) = \sin(k_n x), \quad k_n = \frac{n\pi}{l}, \quad n = 1, 2, 3, \dots \quad (9)$$

Substitution of Eq. (8) into Eqs. (3), (4) yields ordinary differential equations for the Rayleigh

double-beam system. Therefore:

$$\sum_{n=1}^{\infty} \left\{ -a_2 \frac{\partial^2 T_{2n}}{\partial t^2} - b_2 T_{2n} + H_2 T_{1n} \right\} X_n = 0 \quad (10)$$



$$\sum_{n=1}^{\infty} \left\{ -a_1 \frac{\partial^2 T_{1n}}{\partial t^2} - b_1 T_{1n} + H_1 T_{2n} \right\} X_n = 0 \quad (11)$$

where

$$H_1 = \frac{K_2}{\rho A_1} \quad H_2 = \frac{K_1}{\rho A_2}$$

$$a_1 = \frac{GI_1 k_n^4}{A_1 K_1} + \frac{Gk_n^2}{K_1} + \left( 1 + \frac{K_2}{K_1} \right)$$

$$a_2 = \frac{GI_2 k_n^4}{A_2 K_2} + \frac{Gk_n^2}{K_2} + \left( 1 + \frac{K_2}{K_1} \right)$$

$$b_1 = \frac{GEI_1 k_n^6}{\rho A_1 K_1} - \frac{GF_1 k_n^4}{\rho A_1 K_1} + \frac{EI_1 k_n^4}{\rho A_1} \left( 1 + \frac{K_2}{K_1} \right) + \frac{Gk_n^2}{\rho A_1} - \frac{F_1 k_n^2}{\rho A_1} \left( 1 + \frac{K_2}{K_1} \right) + \frac{K_2}{\rho A_1}$$

$$b_2 = \frac{GEI_2 k_n^6}{\rho A_2 K_2} - \frac{GF_2 k_n^4}{\rho A_2 K_2} + \frac{EI_2 k_n^4}{\rho A_2} \left( 1 + \frac{K_2}{K_1} \right) + \frac{Gk_n^2}{\rho A_2} - \frac{F_2 k_n^2}{\rho A_2} \left( 1 + \frac{K_2}{K_1} \right) + \frac{K_1}{\rho A_2}$$

The solutions of equations (10) and (11) can be obtained by:

$$T_{n1} = C_n e^{i\omega_n t}, \quad T_{n2} = D_n e^{i\omega_n t} \quad (12)$$

where  $\omega_n$  denotes the natural frequency of the system. Substituting equation (12) into equations (10) and (11), we obtained:

$$(b_1 - a_1 \omega_n^2) D_n - H_1 D_n = 0 \quad (13)$$

$$(b_2 - a_2 \omega_n^2) D_n - H_2 C_n = 0 \quad (14)$$

When the determinant of the coefficients in Eqs. (13), (14) vanishes, non-trivial solutions for the constants  $C_n$  and  $D_n$  can be obtained, which yields the following frequency (characteristic)

equation:

$$a_1 a_2 \omega_n^4 - (b_1 a_2 + a_1 b_2) \omega_n^2 + b_1 b_2 - H_1 H_2 = 0 \quad (15)$$

Then from the characteristic equation (15), we obtained

$$\omega_{n1}^2 = \frac{(b_1 a_2 + a_1 b_2) - \sqrt{(b_1 a_2 + a_1 b_2)^2 - 4a_1 a_2 (b_1 b_2 - H_1 H_2)}}{2a_1 a_2} \quad (16)$$

$$\omega_{n2}^2 = \frac{(b_1 a_2 + a_1 b_2) + \sqrt{(b_1 a_2 + a_1 b_2)^2 - 4a_1 a_2 (b_1 b_2 - H_1 H_2)}}{2a_1 a_2} \quad (17)$$

For each of the natural frequencies, the associated amplitude ratio of vibration modes of the two beams is given by:

$$\alpha_{ni} = \frac{C_n}{D_n} = \frac{H_1}{(b_1 - a_1 \omega_{ni}^2)} = \frac{(b_2 - a_2 \omega_{ni}^2)}{H_2} \quad (18)$$

From the above analysis we know that solutions (12) can be rewritten as:

$$T_{1n}(t) = C_{1n}e^{j\omega_{n1}t} + C_{2n}e^{-j\omega_{n1}t} + C_{3n}e^{j\omega_{n2}t} + C_{4n}e^{-j\omega_{n2}t}, \quad (19)$$

$$T_{2n}(t) = D_{1n}e^{j\omega_{n1}t} + D_{2n}e^{-j\omega_{n1}t} + D_{3n}e^{j\omega_{n2}t} + D_{4n}e^{-j\omega_{n2}t}, \quad (20)$$

or introducing the trigonometric functions we get:

$$T_{1n}(t) = \sum_{i=1}^2 [A_{ni} \sin(\omega_{ni}t) + B_{ni} \cos(\omega_{ni}t)], \quad (21)$$

$$T_{2n}(t) = \sum_{i=1}^2 \alpha_{ni}^{-1} [A_{ni} \sin(\omega_{ni}t) + B_{ni} \cos(\omega_{ni}t)], \quad (22)$$

where  $A_{ni}$  and  $B_{ni}$  ( $i=1,2$ ) are unknown constants which are determined from initial conditions.

$$A_{n1} = \frac{2\alpha_{n1}}{\omega_{n1}(\alpha_{n2} - \alpha_{n1})l} \int_0^l (\dot{v}_{20}\alpha_{n2} - \dot{v}_{10}) \sin(k_n x) dx, \quad (23)$$

$$A_{n2} = \frac{2\alpha_{n2}}{\omega_{n2}(\alpha_{n1} - \alpha_{n2})l} \int_0^l (\dot{v}_{20}\alpha_{n1} - \dot{v}_{10}) \sin(k_n x) dx, \quad (24)$$

$$B_{n1} = \frac{2\alpha_{n1}}{(\alpha_{n2} - \alpha_{n1})l} \int_0^l (v_{20}\alpha_{n2} - v_{10}) \sin(k_n x) dx, \quad (25)$$

$$B_{n2} = \frac{2\alpha_{n2}}{(\alpha_{n1} - \alpha_{n2})l} \int_0^l (v_{20}\alpha_{n1} - v_{10}) \sin(k_n x) dx, \quad (26)$$

Finally, the free transverse vibrations of an elastically connected double beam system described by the following equations:

$$w_1(x,t) = \sum_{n=1}^{\infty} \sin(k_n z) \sum_{i=1}^2 [A_{ni} \sin(\omega_{ni}t) + B_{ni} \cos(\omega_{ni}t)], \quad (27)$$

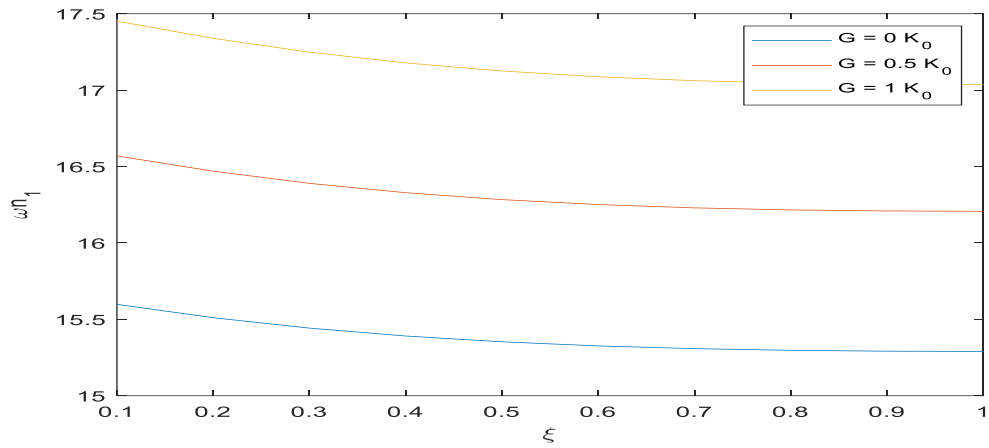
$$w_2(x,t) = \sum_{n=1}^{\infty} \sin(k_n z) \sum_{i=1}^2 \alpha_{ni}^{-1} [A_{ni} \sin(\omega_{ni}t) + B_{ni} \cos(\omega_{ni}t)], \quad (28)$$

## NUMERICAL RESULTS

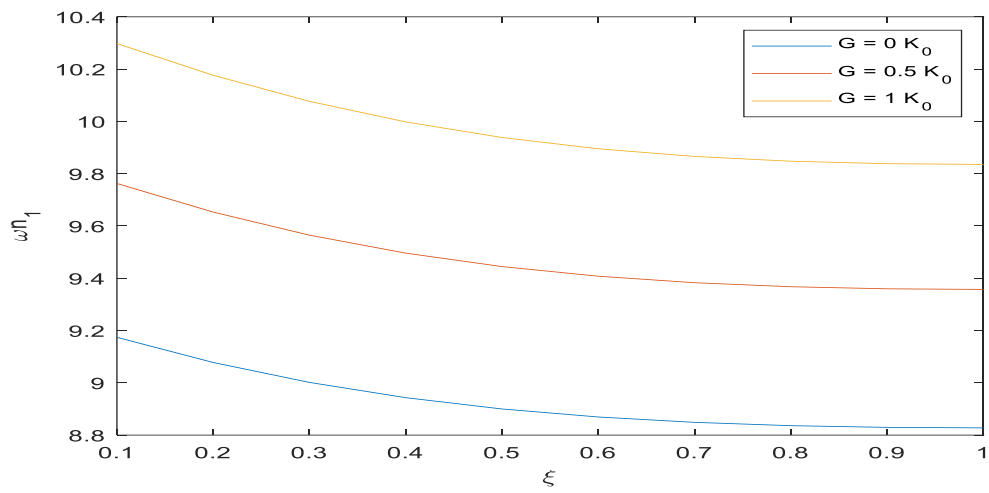
In the numerical experiment, a model of two beams of identical geometrical and physical properties was used [1,3]:

$$A=0.05 \text{ m}^2, E=10^{10} \text{ Nm}^{-2}, l=10\text{m}, I=0.0004 \text{ m}^4, K_0=200000 \text{ Nm}^{-2},$$

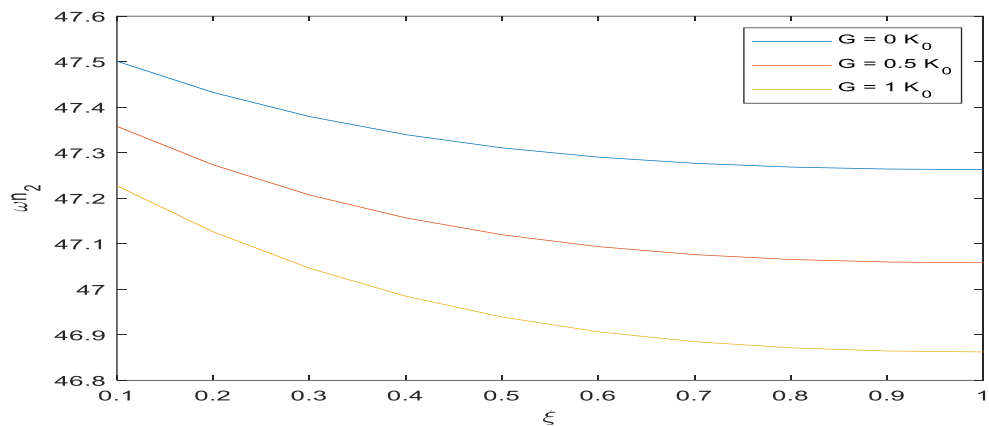
$$G=(0,0.5,1)K_0, \rho=2000 \text{ kgm}^{-3}.$$



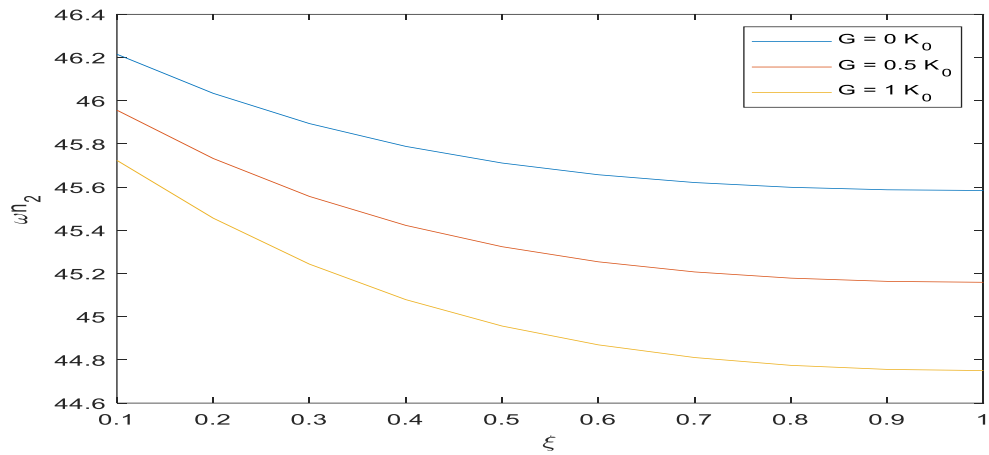
**Fig. 2.** Effect of the axial load ratio  $\zeta$  on the lower natural frequency  $\omega_{n1}$  for  $K=K_0=K_1=K_2$  ( $F_1=0.4 F_b^{cr}$ )



**Fig. 3.** Effect of the axial load ratio  $\zeta$  on the lower natural frequency  $\omega_{n1}$  for  $K=K_0=K_1=K_2$  ( $F_1=0.8 F_b^{cr}$ )

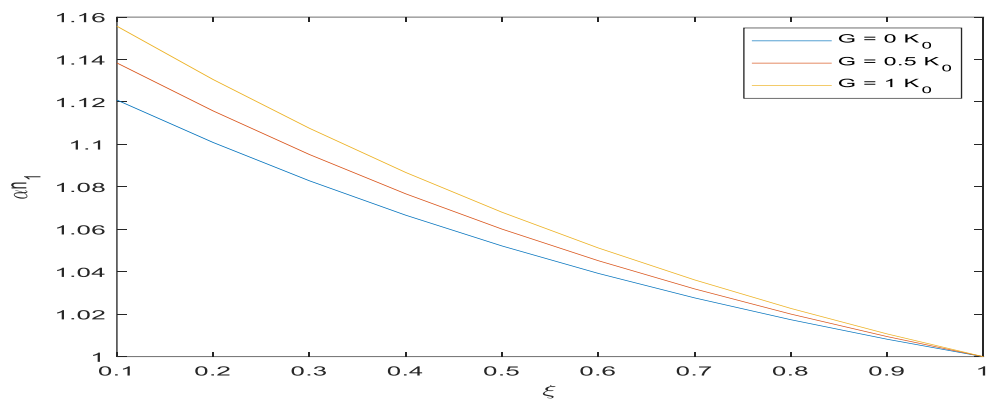


**Fig. 4.** Effect of the axial load ratio  $\zeta$  on the higher natural frequency  $\omega_{n2}$  for  $K=K_0=K_1=K_2$  ( $F_1=0.4 F_b^{cr}$ )

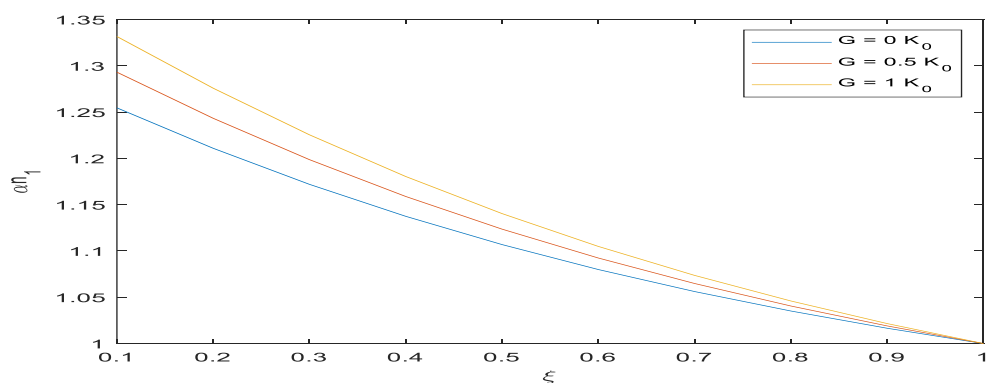


**Fig. 5.** Effect of the axial load ratio  $\zeta$  on the higher natural frequency  $\omega_{n2}$  for  $K=K_0=K_1=K_2$   
 ( $F_1=0.8 F_b^{cr}$ )

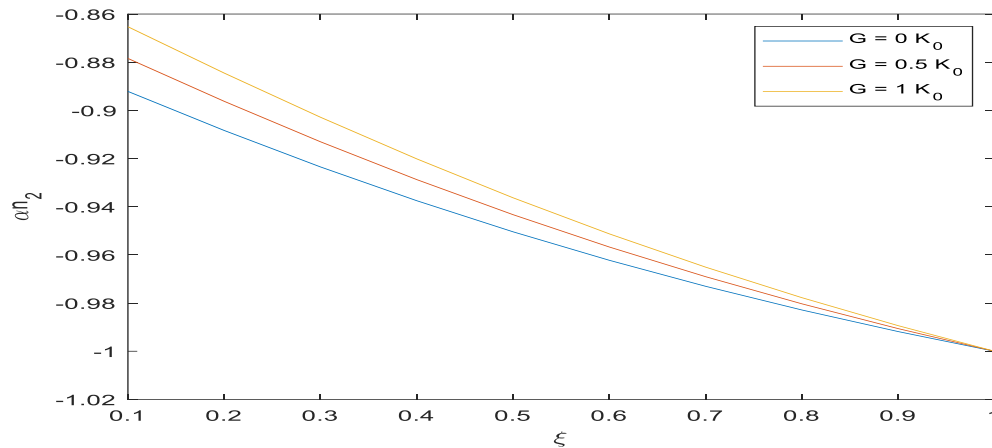
From Figs 2-5, it is seen that the increase of compressive axial load seriatim  $F_1$  causes the reduction of the natural frequency. We also notice that the increase of the shear layer  $G$  causes the reduction of the higher natural frequency  $\omega_{n2}$  and increasing of the lower natural frequency  $\omega_{n1}$ .



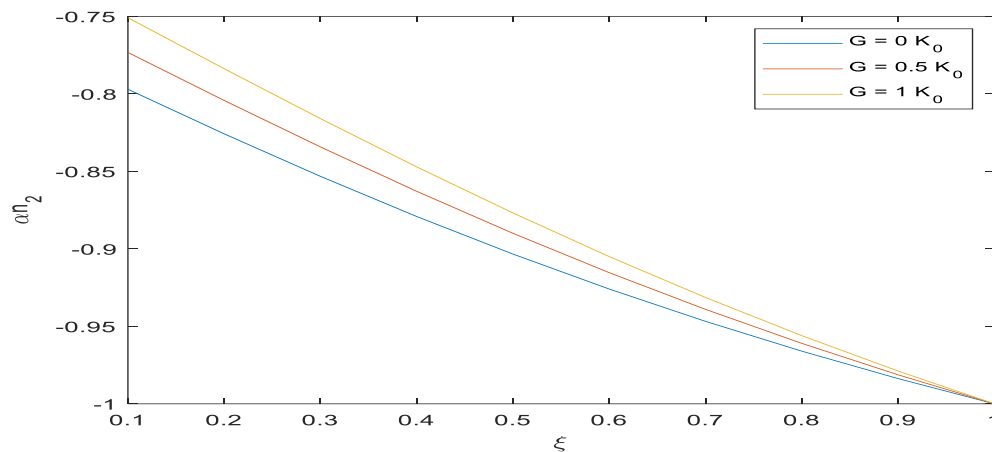
**Fig. 6.** Effect of the axial load ratio  $\zeta$  on the amplitude ratio  $\omega_{n1}$  for  $K=K_0=K_1=K_2$   
 ( $F_1=0.4 F_b^{cr}$ )



**Fig. 7.** Effect of the axial load ratio  $\zeta$  on the amplitude ratio  $\omega_{n1}$  for  $K=K_0=K_1=K_2$   
 ( $F_1=0.8 F_b^{cr}$ )



**Fig. 8.** Effect of the axial load ratio  $\zeta$  on the amplitude ratio  $\alpha_{n2}$  for  $K=K_0=K_1=K_2$  ( $F_1=0.4 F_b^{cr}$ )



**Fig. 9.** Effect of the axial load ratio  $\zeta$  on the amplitude ratio  $\alpha_{n2}$  for  $K=K_0=K_1=K_2$  ( $F_1=0.8 F_b^{cr}$ )

From the figures 10-15 it is seen that the amplitude ratios  $\alpha_{n1}$  and  $\alpha_{n2}$  are influenced by the shear layer constant  $G$  and by the axial load ratio  $\zeta$ . Amplitude ratios  $\alpha_{n1}$  and  $\alpha_{n2}$  are becoming higher with the increase in the shear layer constant  $G$ , but smaller with the increase in compressive axial load ratio  $\zeta$ .

## CONCLUSION

Based on the Rayleigh beam theory, the free transverse vibration of an elastically connected simply supported Rayleigh double-beam, with a Kerr middle layer under compressive axial loading for one case of particular excitation loading are studied in this paper.

Using the classical Bernoulli-Fourier method, the solutions of differential equations of motion for double-beam system are formulated. The explicit expressions are presented for natural frequency, associated amplitude ratio and critical buckling load of the two beams.

From the figures 2-5 can be concluded that the lower natural frequency  $\omega_{n1}$  is more sensitive than higher natural frequency  $\omega_{n2}$  to the compressive axial loading. We also notice that the increase of the shear layer  $G$  causes the reduction of the higher natural frequency  $\omega_{n2}$  and increasing of the lower natural frequency  $\omega_{n1}$ .

From the figures 6-9 can be concluded that the amplitude ratios  $\alpha_{n1}$  and  $\alpha_{n2}$  are influenced by the shear layer constant  $G$  and by the axial load ratio  $\zeta$ . Amplitude ratios  $\alpha_{n1}$  and  $\alpha_{n2}$  are becoming smaller with the increase in the compressive axial load ratio  $\zeta$ , but increase with the increase in shear layer constant  $G$ .

Future research could include the improvement of the considered model. A model of two connected parallel Rayleigh beams with a Kerr layer in between including inerter will be examined.

#### ACKNOWLEDGMENTS

This work was supported by the Serbian Ministry of Education, Science and Technological Development through Mathematical Institute of the Serbian Academy of Sciences and Arts.

#### REFERENCES

- [1] Oniszczyk, Z.: Forced transverse vibrations of an elastically connected complex simply supported double-beam system, *Journal of Sound and Vibration*, 264, pp.273–86, 2003.
- [2] Oniszczyk, Z.: Free transverse vibrations of elastically connected simply supported doublebeam complex system, *Journal of Sound and Vibration*, 232, pp.387–403, 2000.
- [3] Zhang, Y.Q. Lu, Y., Wang, S.L., Liu, X.: Vibration and buckling of a double-beam system under compressive axial loading, *Journal of Sound and Vibration*, 318, pp. 341–352, 2008.
- [4] Stojanovic, V., Kozic, P., Pavlovic, R., Janevski, G.: Effect of rotary inertia and shear on vibration and buckling of a double beam system under compressive axial loading, *Arch Appl Mech*, 81:1993–2005, 2011. DOI: [10.1007/s00419-011-0532-1](https://doi.org/10.1007/s00419-011-0532-1)
- [5] Kozic, P., Pavlovic, R., Karlicic, D.: The flexural vibration and buckling of the elastically connected parallel-beams with a Kerr-type layer in between, *Mechanics Research Communications*, 56, pp. 83–89, 2014.
- [6] Mohammadi N., Nasirshoabi.: Forced transverse vibration analysis of a Rayleigh double-beam system with a Pasternak middle layer subjected to compressive axial load, *JVE International LTD. Journal of Vibroengineering*, 17, pp.4545-4559, 2015.
- [7] Rašković, D.: *Theory of Oscillations*, Scientific book, in Serbian, 1965.
- [8] Rao, S. S.: *Mechanical Vibrations*, 4th Edition, Pearson-Prentice Hall, Upper Saddle River, 2004.
- [9] Kerr, D.A.: Elastic and viscoelastic foundation models, *Journal of Applied Mechanics ASME*, 31, pp. 491-498, 1964.

## MOLD CAVITY LAYOUT DESIGN

Ivan Matin<sup>1</sup>, Branko Štrbac<sup>1</sup>, Miloš Ranisavljev<sup>1</sup>, Đorđe Vukelić<sup>1</sup>, Miodrag Hadžistević<sup>1</sup>

<sup>1</sup>University of Novi Sad, Faculty of Technical Sciences, Department of Production  
 Engineering, Novi Sad, Serbia

e-mail: [matini@uns.ac.rs](mailto:matini@uns.ac.rs)

**Abstract:** This paper presents an approach for plastic part design and its manufacturing. Based on the geometric product specifications of the part, the authors designed runner system and determined associated injection molding parameters. The injection molding parameters are calculated using numerical simulation. The more favorable variant of the two proposed runner systems will initiate the based geometry of the mold cavity.

**Key words:** plastic, injection molding, manufacture

### INTRODUCTION

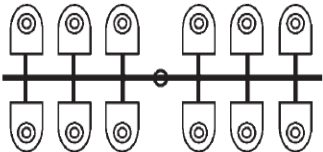
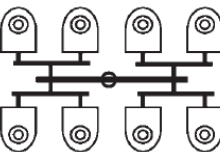
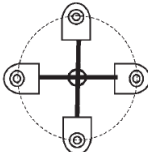
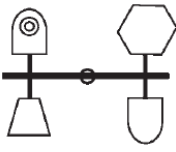
Coeval life cycle assessments (LCA) commend plastics as the noblest contributor to ecology, because it absolutely reduces human dependence on fossil fuels like shrinking 150% energy demand [1, 2]. Ever since Alexander Parkes invented plastic in 1855 to substitute demands of ivory from elephants and whales, tortoise shells and horns, they are preferred over all other material options [3]. Plastic industry is one of the world's fastest growing industries. Almost every product that is used in daily life involves the usage of plastic and most of these products can be produced by plastic injection molding [4-6]. Injection molding is well known as the manufacturing process for creating products with various shapes and complex geometry. The plastic injection molding is a cyclic process. There are four significant stages in the process. These stages are filling, packing, cooling and ejection. The injection molding begins with feeding the resin and the appropriate additives from the hopper to the heating/injection system of injection molding machine [4, 7, 8]. The mold cavity is filled with hot polymer melt at injection temperature in this "filling stage". After the cavity is filled, in the "packing stage", additional polymer melt is packed into the cavity at a higher pressure to compensate shrinkage as the polymer solidifies. This is followed by "cooling stage" where the mold is cooled until the part is rigid to be ejected. The last step is the "ejection stage" in which the mold is opened and the part is ejected, after which the mold is closed again to begin the next cycle [6-9].

### MATERIAL AND METHODS

#### Mold cavity layout design

The mold layout design assumes that the number of mold cavities and type of mold has been determined. To develop the mold layout, the mold opening direction and the location of the parting surface are first determined. Then, the length, width, and height of the core and cavity inserts are selected. The goal of cavity layout design is to produce a mold design that is compact, easy to manufacture, and provides molding productivity. For multi-cavity molds, there are essentially three fundamental cavity layouts such as cavities placed along one line (1a, 1d), cavities placed in a grid (1b) and cavities placed around a circle (1c) which are shown in Table 1 [10].

**Table 1.** Multi-cavity layouts

 <p>a) Unbalanced linear layout</p>	 <p>b) Balanced linear layout</p>	 <p>c) Balanced circular layout</p>	 <p>d) Family mold</p>
--	--	---	---

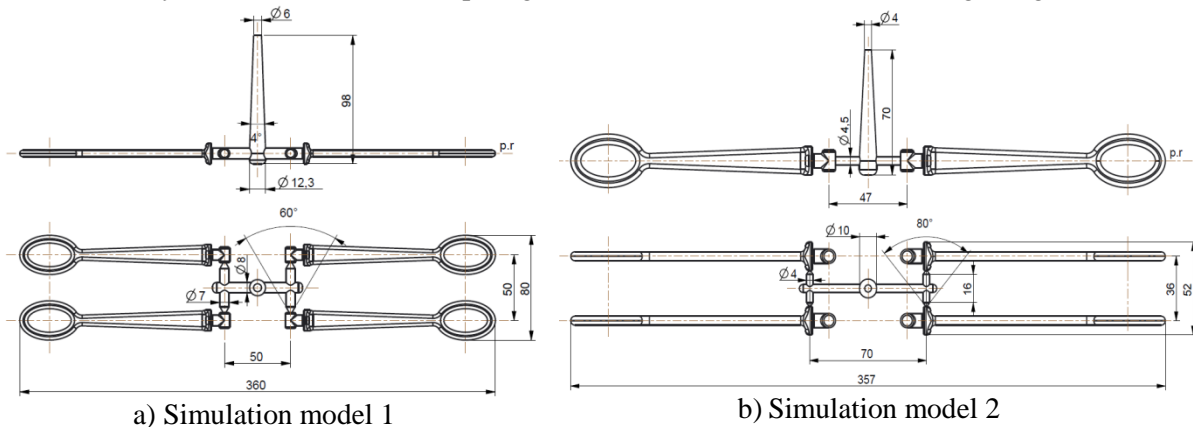
Placing all the cavities along a line, as shown in Table 1, is a simple but poor design. As an alternative to a linear layout of all cavities, it is common to place cavities in a grid. This design is most common for applications requiring high production volumes when the number of cavities is a multiple of 2, 4, 8, 16, etc. There are two primary benefits to a grid layout. First, the grid layout will result in a compact mold with an acceptable aspect ratio. Second, the grid layout lends itself well to naturally balanced runner system. While the grid layout (Table 1b) is compact and very common, it can result in a runner system design with multiple branches. To reduce the runner system complexity and ensure more balanced melt filling, a circular layout is sometimes used when the molded parts are relatively small or when the number of mold cavities is relatively low. Table 1c, shows one such layout in which all the cavities are provided at an equal distance from the center of the mold. The primary disadvantage is that such a circular layout requires a larger mold surface area than grid layouts. A multi-cavity mold that produces different products at the same time is known as a family mold (Table 1d). Multi-cavity mold that produces the same product throughout the molding cycle can have a balanced layout or an unbalanced layout. A balanced layout is one in which the cavities are all uniformly filled at the same time under the same injection molding parameters [10]. A balanced layout can be further classified into two categories: linear and circular. A balanced linear layout can accommodate 2, 4, 8, 16, 32 etc. cavities, i.e. it follows a 2<sup>n</sup> series. A balanced circular layout can have 3, 4, 5, 6 or more cavities, but there is a limit to the number of cavities that can be accommodated in a circular layout because of space constraints [9, 10]. The holder, shown in Fig.1, is used in the following case study. This is constitutive element of the saltshaker assembly, as shown in Fig.1.



a) Saltshaker assembly      b) Holder

**Fig. 1.** The plastic product

The simulation models are generated using iterative redesign procedure into Creo Parametric software package, module for simulation (Pro/Plastic Advisor) and mold design (Pro/Mold Design). The appropriate simulation models consists of the runner system and four CAD parts, as are indicated in Fig. 2. The runner system further consists of sprue gate, main runner, sub runner, cold slug and gate.



a) Simulation model 1

b) Simulation model 2

**Fig. 2.** Simulation models



The runner systems are balanced and acceptable according to injection molding parameters that are determined using numerical simulation.

## RESULTS AND DISCUSSION

The injection molding parameters and its divergences are shown in Table 2.

**Table 2.** The injection molding parameters

<b>The injection molding parameter</b>	<b>Simulation model 1</b>	<b>Simulation model 2</b>	<b>Comment</b>
Material grade	Same	Same	Polypropylenes PP 001
Injection molding machine	Same	Same	All rounder 270s by ARBURG.
Maximal injection pressure	Lower	Higher	Lower is better. Difference is 8 [MPa].
Injection Pressure	Lower	Higher	Lower is better. Difference is 1.5 [MPa].
Maximal melt temperature	Same	Same	Recomended temperature.
Mold temperature	Same	Same	Recomended temperature
Melt temperature	Same	Same	Recomended temperature.
Transition temperature	Same	Same	Recomended temperature.
Quality test results by numerical simulation	High quality. The completely simulated model consists of all green zones.	High and medium quality. The simulated model is green. The runner has only small area of the yellow zone.	Green area has high quality, yellow has medium quality but acceptable and red area has lower quality.
Injection time	Lower	Higher	Lower is better. Difference is 1 [s].
Calculated cycle time	Lower	Higher	Lower is better. Difference is 4 [s].
Max sink marks estimate	0.09 [mm]	0.20 [mm]	Lower is better. The difference is significant.
Surface temperature variance range	3.5 [°C]	4.7 [°C]	Lower is better.
Air traps and weld lines	A smaller number of weld lines that are better positioned.	A larger number of weld lines that are poorly positioned.	Lower is better.
The manufacturing cost of the mold plates	Cheaper	More expensive	The difference is significant.

Cooling time (in the mold)	Shorter time	Longer time	Lower is better. Difference is 1.7 [s]
Maximal estimated shear stress	Better	Worse	Difference is 0.03 [MPa]
Injection point (vestige location)	Visibly in the holder but not visible in the assembly	Visible in the assembly	At the point where the runner system connected with the part, a small imperfection is visible, called the vestige.

## CONCLUSION

The quality test result measures the expected quality of the model's appearance and its mechanical properties by simulation. The quality is derived from combinations of the following five results: flow front temperature, packing pressure, cooling time, shear rate and shear stress. Only if all five results in an area are acceptable, the area is green and the simulation model has a high quality. Yellow area has medium quality, but that is acceptable. The both simulation models are suitable. The first one has favorable characteristics with regard to moldability. To injection mold polymers, designing mold cavity is a key task involving several decisions with direct implications to quality, productivity and frugality. One main decision among them is specifying the runner system. The runner system of the first simulation model is much better due to the previously shown simulation. The both gates are designed for automatic trim of the runner system, so ejector pins will be necessary for automatic trimming of the gates. The objective of the mold layout design is to determine dimensions of the mold to begin procurement of cavity plates. The first simulation model occupies a better position in relation to the parting surface, so the manufacturing costs of the mold cavity are lower. The filling is much more uniform and packing pressure is better distributed and more efficient. As a result, both residual stresses and warpage are lower, air traps and weld lines are reduced to a minimum.

## REFERENCES

- [1] Lakkanna, M., Kumar, G.C.: Kadoli, R., Computational design of mould sprue for injection moulding thermoplastics, *Journal of Computational Design and Engineering*, Vol. 3, pp. 37–52, 2016.
- [2] Tukker, A., *Handbook on Life Cycle Assessment*, Kluwer Academic Publishers, 1-4020-0228-97.
- [3] Rosato, D.V., Rosato, M.G.: *Plastic Design Handbook*, Norwell, MA, USA, Kluwer Academic Publishers, 2001.
- [4] Tang, S.H., Kong, Y.M., Sapuan, S.M., Samin, R., Sulaiman, S.: Design and thermal analysis of plastic injection mould, *Journal of Materials Processing Technology*, Vol. 171, pp. 259–267, 2006.
- [5] Min, B.H.: A study on quality monitoring of injection-molded parts, *Journal of Material Processing Technology*, Vol. 136, 2002.
- [6] Pun, K.F., Hui, I.K., Lewis, W.G., Lau, H.C.W.: A multiple-criteria environmental impact assessment for the plastic injection molding process: A methodology, *Journal of Cleaner Production*, Vol. 11, No.41, 2002.
- [7] Matin, I., Vukelic, D., Hadzistevic, M., Strbac, B., Lukic, D.: An integrated approach for design and manufacture of plastic products, *Journal of Engineering and Applied Sciences*, Vol. 4, pp. 1–5, 2019.
- [8] Fu, J., Ma, Y.: A method to predict early-ejected plastic part air-cooling behavior towards quality mold design and less molding cycle time, *Robotics and Computer Integrated Manufacturing*, Vol. 56, pp. 66–74, 2019.
- [9] Guo, W., Yu, Z., Wei, W., Meng, Z., Mao, H., Hua, L.: Effect of film types on thermal response,

cellular structure, forming defects and mechanical properties of combined in-mold decoration and microcellular injection molding parts, *Journal of Materials Science and Technology*, Vol. 92, pp. 98-108, 2021.

- [10] Low M. L. H., Lee, K.S.: A Parametric-Controlled Cavity Layout Design System for a Plastic Injection Mould, *International Journal of Advanced Manufacturing Technology*, Vol. 21, pp.807–819, 2003.

## VANADIUM IN TOOL STEELS

Zoran Karastojković<sup>1</sup>, Jasmina Pekez<sup>2</sup>, Nikola Bajić<sup>1</sup>

<sup>1</sup>IHIS Technoexperts, Zemun, Serbia

<sup>2</sup>Tehnički fakultet „Mihajlo Pupin“, University of Novi Sad, Zrenjanin

e-mail: [zoran.karastojkovic@gmail.com](mailto:zoran.karastojkovic@gmail.com), [jasminapekez@gmail.com](mailto:jasminapekez@gmail.com)

**Abstract:** In the long history in producing the tool steels, vanadium was used just accidentally, when is introduced in steel from ores in local area. But many ores did not contain the vanadium in any form, so the role of positive effect of this alloying element on steel properties was not well known or explained. In a contemporary metallurgy the vanadium is recognized as an important alloying element, both in structural or tool steels. Vanadium is known as an element which is chemically highly active, and from that reason it could not be found in a native state, only as compounds. Such great chemical activity still is a problem in melting and alloying the steels by using vanadium (almost in small quantities) in traditional melting techniques.

The increasing of strength properties and decreasing wear of a steel, when small amounts of vanadium was added, is discovered in the early 20th century. Vanadium reacts with almost of interstitial elements, but the reactions with carbon and/or nitrogen are of special interest for tool steels. In recent decades the powder metallurgy offers some advantages in producing pretty qualitative tools, with higher level of vanadium. Here is made an overview on the role of vanadium in tool steels.

**Key words:** vanadium, tool steels, interstitial elements, wear resistance.

### INTRODUCTION

It seems that using of vanadium goes back in the 3rd Century BC [1], without extracting & using as a pure metal or ferroalloy, but rather as ingredient in local ores. Vanadium plays an important role in (micro)alloyed steels, but for severe working conditions of steel vanadium becomes more interesting alloying element, especially in tool steels in which is present up to a few percent. At the beginning of XX century Henry Ford used vanadium to make the body of one type of car to be stronger and lighter. Vanadium steels, with improved heat resistance, were used in portable artillery in the First World War. Either of such applications, vanadium is present at supplements which are used in medicine (for treating diabetes, low blood sugar, high cholesterol, heart disease, tuberculosis, anemia, improving athletic performance, etc.).

Powder metallurgy (PM) technology find out an important role in producing of tool steels with high percent of vanadium, which commonly are unable to produce by conventional metallurgical methods.

### MATERIAL AND METHODS

#### Iron - vanadium phase diagram

Vanadium is a lighter element than pure iron, it has a density of 6.11gm/cm<sup>3</sup>, melts at 19100C, when in liquid state possess density of 5,5 gm/cm<sup>3</sup>, so it makes a problem during alloying the molten steel. Vanadium has a body centered cubic lattice. Every approach in understanding the role of vanadium in steel begins with the phase diagram iron-vanadium, Fig. 1. Vanadium belongs to a group of alfa phase formers, and affects during the solidification process on narrowing the temperature interval during crystallization, same figure. As in high chromium steels, at high percentage of vanadium will be formed brittle sigma ( $\sigma$ ) phase. The reduction of carbon solubility during temperature decreasing, with narrow  $\gamma$ -phase region as could be seen from Fig. 1, leads to precipitation of vanadium carbides & nitrides in steel.

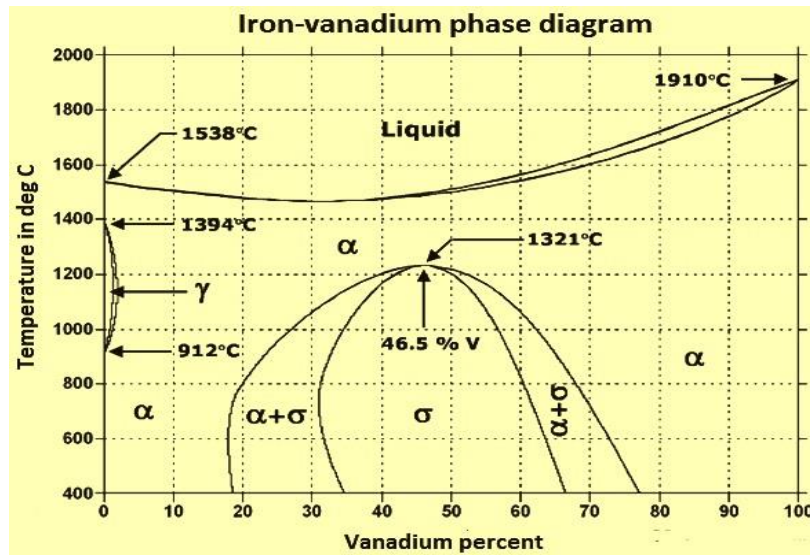


Fig. 1. Iron – vanadium phase diagram

### Vanadium and interstitial elements in steel

Many steels contain a small amount of interstitial elements, as carbon, oxygen and nitrogen, which commonly show an important influence of many properties. Vanadium as an alloying element in steel makes a versatile phase, even compounds with mentioned interstitials. Those phases and compounds are present in structural or tool steels. In structural steels vanadium is used since a long time for producing so called micro alloyed steels. In small amounts vanadium increases both the yield and tensile strength of carbon steels. The presence of vanadium in structural (micro alloyed, HSLA or similar) steels commonly is on level from 0.10% up to 0.25%, while in tool steels could be reached up to a few percent, especially in tool steels produced by PM techniques this level is pretty higher, up to 10%, rarely higher.

Vanadium alone or with other microalloying elements present in steel, as aluminium, niobium and titanium, contributes the increasing of strength, as first discovered in carbon-manganese structural steel. The action of vanadium for increasing the strength is explainable by formation of precipitates in the form of carbides, nitrides or carbonitrides. The refinement of the ferrite grain size could not be neglected, so the fine grains are also present in steel even at elevated temperatures. After tempering of quenched steel, vanadium (but not alone) causes secondary hardening. Those reactions are truly explanation for improving the strength with increased hardenability, even though the formability of such steels is better. As a result, vanadium steels are used in production of versatile structural components in civil engineering, automotive industry, etc. Vanadium in high-speed steels (HSS), of course with obvious presence of carbon, provide high values of hardness (above 60HRC). Some of these steels are used as surgical instruments.

Carbon and nitrogen as interstitial elements are responsible for reactions that took place in steels (micro)alloyed with vanadium. Those reactions led to so called precipitation strengthening, when strength is increased with increasing the carbon content (at all levels), additionally by the presence of nitrogen, Fig. 2 [3]. The precipitation strengthening and hardening is affecting by cooling regime (either during heat treatment or after hot deformation), in steels through a wide carbon content. The improving the strength, hardness and toughness is caused by formation of stable V-carbides and/or nitrides, which could be attributed as VC<sub>1-x</sub> and VN<sub>1-x</sub>, respectively. These vanadium carbides and nitrides are highly soluble in the ferrite and/or austenite, contributes to increasing the wear resistance. Fine austenite grains will produce a finer ferrite grains during cooling, causing a better toughness of a steel.

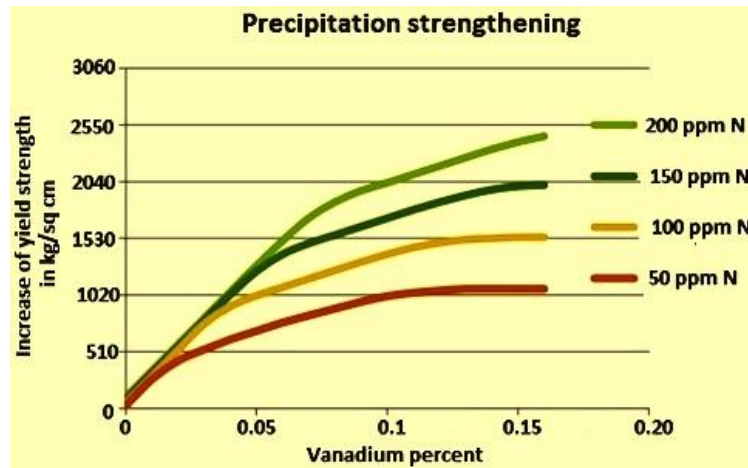


Fig. 2. Increasing of yield strength as a function of vanadium content for various nitrogen amounts

The concentration of vanadium according to nitrogen could be maintained at or above the ratio of 4:1, for formation of vanadium nitrides – which took place just below the liquidus temperature. It's worthy to underline that the solubility of vanadium carbides into the austenite is higher than niobium or titanium carbides, but the solubility of vanadium nitride is lower than of vanadium carbide. In steel alloyed with vanadium is registered the absence of Widmannstetter ferrite (during cooling after hot deformation or long duration of heat treatment regime), and this is another explanation for improving the toughness of such alloyed steels. Hardnesses of the most important carbides, which commonly could be found in steels, are shown in Table 1. According to shown data is understandable that the role of vanadium in steels is to make hard carbides.

Table 1. Hardness of quenched steel and important carbides in steels

Kind of distribution in rolled steel	Material	HRC
	Quenched steel	60 – 65
	Chrome carbides	65 – 68
	Molybdenum carbides	72 – 77
	Wolfram carbides	72 – 77
	Vanadium carbides	82 – 84
	Boron carbides	82 – 84

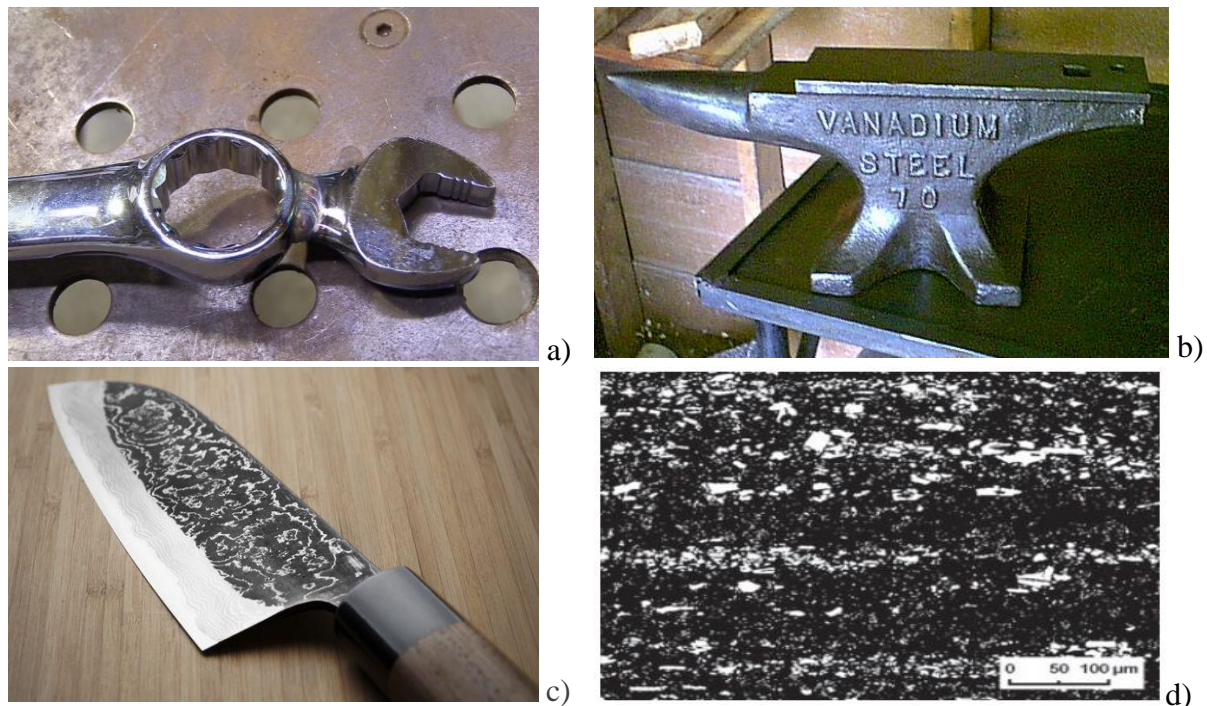
### Vanadium in tool steels

Vanadium is used in all kinds of tool steels, almost in limited amounts. So, it could be found in variety of cold and hot working tool steels. In recent years is increased the use of vanadium in special kinds of steel, when a high wear and/or abrasion resistance is needed.

#### Vanadium in tools for cold work

A lot of tools for cold work obviously contain carbon and chromium, commonly with 0,10-0,30%V, some of them up to 1%V. Cold work steels generally contain another alloying elements as wolfram and molybdenum, when high hardness, strength and wear resistance are demanded. Quenchability of steels with vanadium, generally, is on satisfied level, first of all according to medium or large amount of carbon, sometimes up to 2%C. When vanadium is present than the strength and wear resistance are increased in steel, these properties are however suitable for tools as like: for cutting, forming die applications, cold extrusion, deep drawing, etc.

From the metallurgical point of view, the role of vanadium in steels is considered in relation to the temperature over Ar<sub>3</sub> point, more precisely it is important for heat treatment purpose. Hardened cold work tool steels achieve hardness generally in range of 58-64HRC, mainly 60-62HRC, and only occasionally up to 66HRC. A few examples of tools, known to everyone, are shown in Figs. 3a÷c).



**Fig. 3.** Common tools for hand use a-c) and microstructure of rolled tool steel (2% C, 12% Cr)

Coarse carbides, as in Fig. 3d), usually should be avoided.

#### *Chromium - vanadium steels*

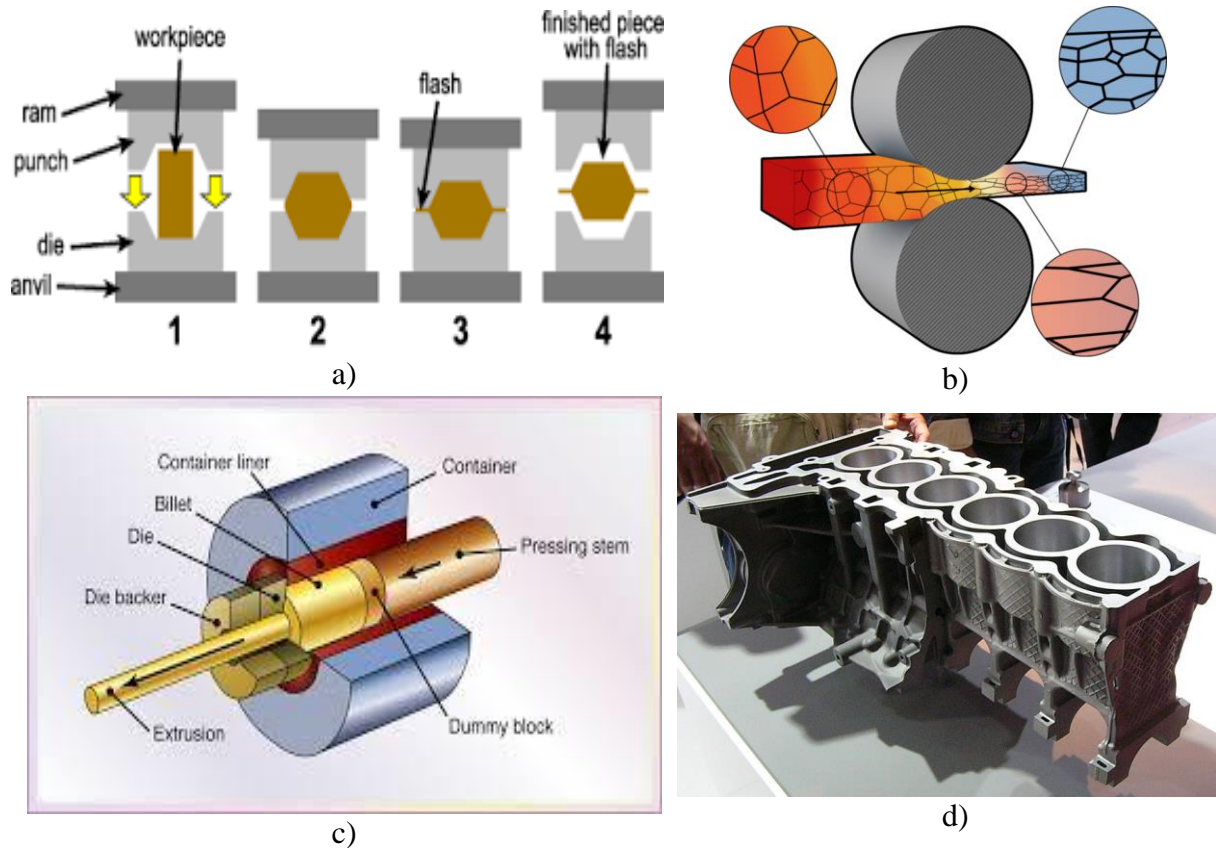
These steels are in using for hand tool manufacturing, one of the most known example is from Fig.3a). Those tools are made from medium carbon steel (0,5%C), alloyed with: 0.7-0.9% manganese, 0.8-1.1%Cr and 0.18%V. Anvils, one example is shown in Fig. 3b), frequently are making from steel or cast iron by using vanadium or wolfram, even molybdenum as alloying element. It is understandable that those steels or irons must possess high hardness, strength, toughness and wear resistance, some of these at elevated working temperature during hammering. Small amounts of boron in this kind of steel is welcome. Various tool steels for cold working, as cutting (see Fig. 3c) or die tools, contain vanadium.

#### *Manganese – chromium – vanadium steels*

These steels usually contain about 0.9%C with greater amount of manganese 2.0%, less chromium (0.3%) then previous steel, and vanadium  $\approx$ 0.10%. The main characteristic of this kind of steel is in stable dimensions, so is used for measuring tools, in Yugoslavia this steel (Č3840) is called merilo.

#### **Vanadium in tools for hot work**

Hot working took place through few different manners: forging, rolling, extrusion and die-casting, Fig. 4. In named processes simultaneously act both the high temperature and pressure, it means that tools should retain their properties in such circumstances. So, the chemical composition of those steels must be precisely determined.



**Fig. 4.** Main hot working processes in metal fabrication: a) forging, b) rolling, c) extrusion and d) specific castings obtained by die-casting

This great group of tool steels also contain vanadium in amount from 0,4 up to 1,0%, carbon is on level 0,35-0,45%, with chromium (up to 5%), wolfram and molybdenum. Tools for hot die forging should contain this valuable element. Die-casting is provided by using a high pressure, for fulfil the mold cavity by molten metal, according to that in these molds the main failure mode is erosion and wear. In such environment the presence of vanadium is just needed. Design of die-casting mold is pretty complex, so there are various used steels for a large number of components, with their hardnesses, as can be seen from Table 2. for the most used casted metals.

**Table 2.** Tool steels and their hardness for important die components for various cast alloys

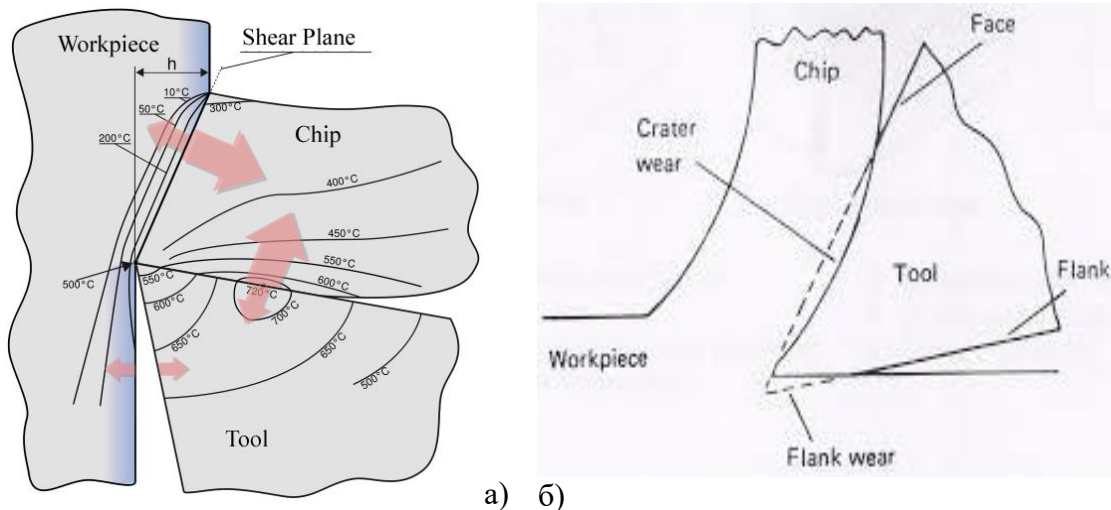
Die component	Cast metal					
	Tin, lead & zinc		Aluminium & magnesium		Copper & brass	
	Material	Hardness	Material	Hardness	Material	Hardness
Cavity inserts	P20	290-330 HB	H13	42-48 HRC	DIN1.2367	38-44 HRC
	H11	46-50 HRC	H11	42-48 HRC	H20,H21, H22	44-48 HRC
	H13	46-50 HRC				
Cores	H13	46-52 HRC	H13	44-48 HRC	DIN 1.2367	40-46 HRC
			DIN 1.2367	42-48 HRC		
Core pins	H13	48-52 HRC	DIN 1.2367 prehard	37-40HRC	DIN 1.2367 prehard	37-40 HRC
Sprue parts	H13	48-52 HRC	H13 DIN 1.2367	46-48 HRC 44-46 HRC	DIN 1.2367	42-46 HRC
Nozzle	420	40-44 HRC	H 13	42-48 HRC	DIN 1.2367 H 13	40-44 HRC 42-48 HRC
Ejector pins	H 13	46-50 HRC	H13	46-50HRC	H 13	46-50 HRC



<b>Plunger shot sleeve</b>	H 13	46-50 HRC	H 13 DIN 1.2367	42-48 HRC 42-48 HRC	DIN 1.2367 H 13	42-46 HRC 42-46 HRC
<b>Holder block</b>	4140 prehard	~300 HB	4140 prehard	~300 HB	4140 prehard	~300 HB

### Vanadium in high speed steels

High speed steels are exceptional group of tool steels, with the highest demands in many properties. As one of those properties is high hardness and wear resistance just at the cutting edge. During cutting the temperature is rising in workpiece, cutting edge and chip, see Fig. 5a) for details.



**Fig. 5.** Temperature distribution during turning a) and wear at turning b)

Wearing zones of cutting tool edge is shown in Fig. 5b). Hard compounds in a tool steel, as vanadium carbide or nitride, contribute to the decreasing of wearing. So, this group of steel contain a higher level of carbon, usually about 1%, and must be high alloyed with wolfram, molybdenum, cobalt, etc., but most of them contain vanadium, usually about 1.5-2% V, and for a heavy working conditions some of HSS steel contains up to 5%.

### Vanadium in abrasion resistant tool steels

Vanadium is the most used alloying element for improving the wear & abrasion resistance. This is particularly special kind of tool steel, mainly used in mining for mineral crushing, etc. Vanadium is irreplaceable in this kind of steel (chromium-molybdenum), offering both high hardness and abrasion resistance, thanks to the hard vanadium carbides, see table 1. Main problem in using of vanadium during melting & alloying of a steel is in great chemical activity of vanadium to oxygen, carbon and/or nitrogen, so the contest of vanadium in such produced steels is limited. Problem in alloying with high percent of vanadium in common melting procedures is solved by using another technique - so called powder metallurgy. Main advantage of this technique is in mixing of powder(s) of pretty different metals, including compounds. After that, the powders are compacted and sintered. On this way is possible to produce a kind of high alloyed tool steel with contest of vanadium at 10%, even more. Such alloyed steel practically is impossible to obtain by classical metallurgical schedule.

Another suitable technique for improving the surface against the wear & abrasion is a surface treating, in this case it means cladding rather than heat treating or nitriding of the vanadium steel. Because the powder to be used for cladding must contain a heavy melting metals or compounds, the laser beam is acceptable as a high energy beam. Plasma beam also offers a needed high temperature for melting, but the plasma stream is too fast & strong and usually blow up a powder to be cladded. One example of used powder for laser cladding is given in Table 3.

**Table 3.** Chemical composition of MicroMelt 23 powder used for laser cladding, Fe bal, [18]

Element	C	Si	Mn	Cr	Ni	W	Mo	Co	Cu	V
mas. %	1.26	0.6	0.37	4.2	0.28	6.45	5.0	0.6	0.16	3.1

As a carrier and shielding gas was used argon. It is evidenced [8] that by using a laser cladding is possible to obtain a thick coating up to 3mm, see Fig. 6.



**Fig. 6.** Laser cladding of Vanadis23 powder on ring (20mm wide and 60mm in diameter) form C45 (ČI530) steel substrate: a) single layer; b) 3mm thick layer (with 30% overlapping); c) and d) single and double layer and e) after machining and grinding

## CONCLUSION

The most tool steels are exposed to a heavy working conditions. It is established that vanadium is a pretty useful alloying element in many tool steels, from cold & hot working conditions, and/or in high-speed steels. Tools for severe working conditions, especially when abrasion resistance is of great importance, simply must contain vanadium, it is explainable by formation of very hard vanadium carbides or nitrides.

By classical metallurgical melting and alloying procedures could be achieved vanadium concentration in tool steel on level up to 2%, rarely 5%, but by using a powder metallurgy technique (including sintering) now is possible to produce a high alloyed tool steel up to 10%V, even more. The newest technology may use a laser beam for cladding, with increased content of vanadium. When cladding technique is applied than as a parent, material could be used a kind of cheaper structural steel, as here is reported.

## REFERENCES

- [1] Kovács G., Kot S.: Facility layout redesign for efficiency improvement and cost reduction, *Journal of Applied Mathematics and Computational Mechanics*, Vol 16, No 1, pp. 63-74., 2017.  
[https://www.researchgate.net/publication/221511773\\_Design\\_of\\_Product\\_Oriented\\_Manufacturing\\_Systems](https://www.researchgate.net/publication/221511773_Design_of_Product_Oriented_Manufacturing_Systems)
- [2] Jurković M.: *Reinženjering proizvodnih poduzeća, Razvoj i modernizacija proizvodnje*, Univerzitet u Bihaću, Bihać, 2011.
- [3] Kunica Z.: *Projektiranje proizvodnih sustava*, Fakultet strojarstva i brodogradnje Sveučilišta u Zagrebu, 2016. (<http://titan.fsb.hr/~zkunica/nastava/pps.pdf>)
- [4] Muther, R., Hales, L.: *Systematic layout planning*, Management & Industrial Research Publications, USA, 2015.
- [5] Barnwal, S., Dharmadhikari, P.: Optimization of plant layout using slp method, *International Journal of Innovative Research in Science, Engineering and Technology*, Vol. 5, Issue 3, March 2016.
- [6] Carmo-Silva, S., Carvalho Alves, A.: Detailed design of product oriented manufacturing systems, Fifth IFIP/IEEE International Conference on Information Technology for Balanced

Automation Systems in Manufacturing and Services (BASYS'02), Cancun, Mexico, September 25-27, 2002.

- [7] Zelenović D.: Projektovanje proizvodnih sistema, Fakultet tehničkih nauka u Novom Sadu, 2009.
- [8] Zrnić Đ.: Fabrička postrojenja, I deo – projektovanje fabrika, Mašinski fakultet Univerziteta u Beogradu, 1990.

## STUDY ON THE DRIVER ERGONOMIC POSITION INSIDE DIFFERENT TYPES OF VEHICLES

Alexandru Dumitru Antonie<sup>1</sup>, Adrian Eugen Cioabla<sup>1</sup>

<sup>1</sup>University Politehnica Timisoara, Faculty of Mechanical Engineering, Timisoara, Romania  
e-mail: [adrian.cioabla@upt.ro](mailto:adrian.cioabla@upt.ro)

**Abstract:** The present work involves the study of ergonomic approach in case of two different vehicles, considered to be vintage (collection) vehicles for determining the ergonomic posture for different scenarios, with direct impact on the driver. This part is very important, taking into consideration the time spent for different job types in the vehicle. Comparative results were made for the two considered vehicles and conclusions were traced in regard to the tested scenarios.

**Key words:** ergonomics, driver posture, vehicle comfort

### INTRODUCTION

Automotive ergonomics is the study of how automotive can be designed better for human use. The human factor aspect of designing automobiles is first considered at the Vehicle Packaging stage. The term Vehicle Packaging comes to use whenever a new model is in the early stage of study. It is a method to safeguard and protect space for the human user and necessary components that make up the vehicle being designed. Other purposes are to provide alternative solutions and proposals, to ensure the legal requirements are met and to ensure all in-house requirements are met. This study is to correlate automobiles interior dimensions to comfort factors by means of measuring.

Vehicle Packaging in short is the organization of space for people and the parts of a vehicle to suite a specific need or transport. It is the first consideration for shaping the vehicle. At Vehicle Package stage, factors such as engine size, weight, width, height, luggage, number of passengers and their seating arrangement are targeted. Knowing all the said parameters plus more will help to establish a range of dimension within a category of vehicle types and cost, enabling the designer to target the shape of vehicle on a "family of dimensions" that will make it competitive.

Vehicle Packaging actually dictates of how a vehicle should be designed. It provides all the necessary information for the styling designers and part designers to proceed with at the following stage. Without vehicle packaging input, all the design engineers will not be able to proceed with the design concept in details. On the other hand, since Vehicle Packaging is meant to provide suitable space for people and parts in vehicle, human factor consideration is a must for the integration of the total design. In vehicle design, the term human factor is interchangeably called as automotive ergonomics [1].

In designing an automobile, there have to be certain dimensions that have been agreed for by the management, design, and manufacturing departments. As much as design attractiveness is important, so do the cost factor and manufacturing capability. Design has to be aligned with proper product positioning and budget as well as manufacturing line setup. To make sure all these factors merged in, vehicle packaging takes all this factors in drafting the total layout of the automobile. Ideally, a perfectly packaged automobile will definitely determine the number of sales. One must not misconstrue vehicle packaging as the total deciding factor for sales. Instead, Vehicle Packaging is the starting point of an automobile design processes. Other major sales factor such as quality of components relates to later stage of design where it deals with a lot of other factors which is outside the scope of this paper [2].

The role of ergonomics is to increase the efficiency and productivity of production and improve health, safety and comfort of people in their work environment. Ergonomics relies on a large number of scientific disciplines including physiology, biomechanics, psychology and anthropometry. An important component of ergonomic research of a vehicle is a prediction and development of a passenger's space in the vehicle [3].

The interior of the car can have a significant impact on both mental and the physical health of drivers and passengers. Seats in the vehicle are one of the main issues during the design because they determine the position of passengers in relation to all other components in the vehicle [4]. During

driving, especially in long periods, seat comfort is very important. Comfort is defined as a condition where the traveler feels relaxed and where you do not feel pain, heat, cold, etc. Lose Loosely designed seats could negatively affect the passengers, and even lead to serious injury [5], [6].

## METHODS

In order to understand the differences between how an USA car manufacturer and an European car manufacturer designs their driving position we will compare two cars, one designs for the USA market, Cadillac Deville Sedan, and a car made for the European market, Rolls Royce Silver Wraith II. Both cars were produced in the 70s. We will analyze the driving position of both car and we will see if it is any difference between three siting position in the car.

## RESULTS AND DISCUSSION

For this experiment we will analyze three driving position:

- The driving seat will be put in at the maximum distance from the steering wheel;
- The driving seat will be put in the position that offer the most comfort for the driver;
- The driving seat will be put in at the minimum distance from the steering wheel.

To be able to analyze the driving position we will measure the following angles that are present in Fig. 1.

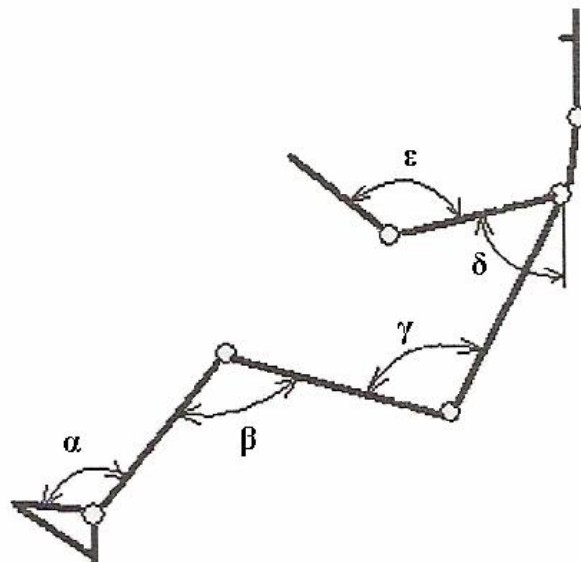


Fig. 1. Angles of driving position

Table 1. Driving position for Cadillac Deville Sedan

Angle [°]	Driving position		
	Position 1	Position 2	Position 3
$\alpha$	82	85	65
$\beta$	123	92	60
$\gamma$	87	88	90
$\delta$	80	70	140
$\epsilon$	152	121	100

Table 2. Driving position for Rolls Royce Silver Wraith II

Angle [°]	Driving position		
	Position 1	Position 2	Position 3
$\alpha$	81	88	92

$\beta$	101	110	119
$\gamma$	101	98	94
$\delta$	51	48	45
$\varepsilon$	85	92	100

From tables one and 2 it can be observed the following:

- Position 1 – depending on the driver, this position is one of the most uncomfortable because the initial driver setting is fixed, with no possibility to modify that much. This can affect the posture, can bring stress upon the hands and legs and also can have an impact on the driver road visibility. For the presented case, the knee angle (beta), varies a lot from one model to the other because of the overall car setting and geometry for the internal space. This position is much more suitable for a tall driver. The elbow angle is inverse proportional in the presented scenario, bringing potential discomfort relative to reduced hand movement possibility.
- Position 2 – in this case, this position is different for every driver, allowing them to adapt the seat settings according to the specifications of each individual. This position is the most suitable because it offers maximum comfort and safety for the driver and the traffic participants.
- Position 3 – the driver will be very close to the steering wheel, depending on the class of used vehicle and this can affect the eye – hand coordination in combination to the different blind angles that have to be compensated because of the restricted visibility field and hand / leg reduced distance.



**Fig. 2.** Driving position for first and second situation



**Fig. 3.** Driving position for the third situation

Usually, this position is more suitable for shorter drivers and in the presented scenario the knee angle (beta) is in a comfort range for the second vehicle, while the elbow angle (epsilon) is identical for the two vehicles.

## CONCLUSION

It can be observed that both car manufacturers, even in the 70s, take in consideration that the driver need to have a good driving position. After measurements one can observe that in both cars the driver was able to find a good driving position, but for all the reduced comfort scenarios it has to be taken into consideration the specific height and overall general dimensions of the driver, because different scenarios can be applied to different drivers from a physical point of view.

## REFERENCES

- [1] Adreoni, G., Santambrogio, G.C., Rabuffetti, M., Pedotti, A.: Method for the analysis of posture and interface pressure of car drivers, *Applied Ergonomics*, 33(6), pp. 511-522, 2003.
- [2] Chaffin, D.: *Digital human modeling for vehicle and workplace design*, Premiere Series Books, SAE International, 2001.
- [3] Eppinger, S. D., Ulrich, K. T.: *Product Design and Development*, The McGraw-Hill Companies, New York, 2008.
- [4] Radcliffe, N.: *Kinetic Modeling and seat factors relating to manikin-seat interaction in automobiles*, Thesis for the Master of Science Degree, Department of Materials Science and Mechanics, Michigan State University, 2001.
- [5] Scheffer, C., Cloete, T.: *Benchmarking of a full-body inertial motion capture system for clinical gait analysis*, IEE, Vancouver, British Columbia, Canada, pp. 4579-4582, 2008.
- [6] Helander, M.G., Zhang, L.: Field studies of comfort and discomfort in sitting, *Ergonomics*, vol. 20, no. 9, pp. 865-915, 1997.

Session 2:

**Energetics and Process Technique**



## THE DEVICE FOR THE PRODUCTION AND THE USAGE OF THE BIOGAS THROUGH THE ANAEROBIC FERMENTATION OF THE MIXTURE OF THE FRAGMENTED BIOMASS AND THE STABLE DUNG

Slavica Prvulović<sup>1</sup>, Jasna Tolmač<sup>1</sup>, Milica Josimović<sup>1</sup>, Ivica Micić<sup>1</sup>, Miloš Josimović<sup>1</sup>

<sup>1</sup>University of Novi Sad, Technical Faculty "Mihajlo Pupin", Zrenjanin, Serbia

E - mail: [prvuloviclavica@yahoo.com](mailto:prvuloviclavica@yahoo.com)

**Abstract:** In this paper the technical description and the principle of work of the device for the production of the biogas are given. The technological parts of the device, the flow of raw material and liquid substrata, the flow of the biogas and the CHP device are presented. The quantity of the entry- raw material and the contribution of the biogas, as well as the contribution of the electricity and thermal energy, as well as the energy which is used while exploitation of the device are calculated.

**Key words:** Biogas device, biogas, CHP device, electricity, thermal energy

### INTRODUCTION

Since the natural resources are not sufficient to meet people`s needs for the electricity and the thermal energy, because their sources are limited, and especially because of the fact that the environment is polluted through the emission of the great quantity of harmful gases into the atmosphere, while combustion of the liquid and gaseous fuels, the development of the new alternative solutions for the accomplishment of the demands of the users of the energy has taken place. The renewable resources of the energy are everywhere around us, the nature has given us the possibility to close the complete energetic circle by them, but they are not sufficiently used. By using the biomass, firstly from the agricultural waste, the need of the country for the import of the energy sources would be reduced, the protection of the environment would be raised to a higher level, the economy would be improved, the unemployment, of, firstly, local inhabitants in less-developed countries, will be reduced, and their migration from these areas into towns and cities will be prevented [1-3].

The biomass is the renewable source of the energy, the organic decomposable matter of plant or animal origin, as well as the biodegradable part of the industrial and town- waste which is transformed into more aspects of energy by different processes. The energy which is gotten in this way is mainly used for the production of the electricity and thermal energy [4-6].

The biomass is the renewable source of energy which is suitable for the production of the electricity, thermal energy, gas and liquid fuels. The biogas consists of the methane (55-80%) and carbon dioxide (20-45%). The energetic value of only methane and hydrogen is important. H<sub>2</sub>S and ammonium hydroxide are problematic, and they should often be removed before the usage of the biogas, in order for them not to react aggressively onto that equipment [3, 7-9].

The pond- gas, the gas from the anaerobic devices for the processing of the liquid waste, septic tanks and so on, the gas from the solid-waste areas, the gas made in the agriculture (firstly from the rice fields, but also from the compost, from the digestive tract of the animals (mainly ruminants) and so on) count as biogas .

The biogas is used for the production of: the thermal energy, of the thermal energy and electricity (co-generation by biogas devices) – this is the most frequent case, and for the energy of cooling (tri generation) [10-12].

Sometimes it is used for cars (mainly town buses), but, considering the fact that it requires the previous preparation, it cannot always be called the car- fuel.

## MATERIAL AND METHODS

### The principle of the work of the biogas device

#### Entry-raw materials

The basic substratum which is used in the process of the production of the biogas is the corn- silage, Sudanese grass and cow- stable dung.

However, the possibility of using other raw materials such as: food- products which are used after the expiration date (if they are hygienically secured), the rotten seed, beet noodle, molasses, fruit- pulp, the waste from the processing of the fruit and vegetables, seeds, peel, the fruit which has fallen down, the leftovers of the food which was not eaten, the leftovers from the beer industry, the leftovers from the production of milk and cheese, the leftovers from the production of oil...

The entry- raw material is disintegrated and fermented in the biogas device (the time of the keeping the mass in the fermenter > 50 days) and after that it is stored in the final storage (the lagoon with the plastic foil) until the period in which the stable dung can be carried out onto the agricultural area (after 180 days, that is, twice a year). The fertilizer which is gotten after the fermentation, is given to the agriculturalists for the fertilization of the area. The biogas which is gotten is stored in the dome of the fermenter (the soft storage under the tandem double membrane), it is transported, condensed and transformed in the CHP unit (the motor for the combustion of the biogas) into the thermal energy and electricity[7, 8,15].

The electricity which is produced is delivered to the network of the local distributor of the electricity. The thermal energy of the co- generation unit is used as the process- thermal energy for the fermentation and for the heating of the object for the management and supervision (< 20% of the total thermal energy for the heating of the fermenter and for the heating of the object for the management). In the case that there is not the need for the thermal energy or, for some reason, some of the systems for the distribution of the thermal energy towards the device or the power station have failed, the system transfers the cooling of the motor towards the refrigerating towers automatically, as a coercive form of the servicing the system.

### The value of the gas and the contribution of the energy

The content of the biogas consists of: methane CH<sub>4</sub> ca. 50 - 55 %, carbon dioxide CO<sub>2</sub> ca. 45 - 50 %, nitrogen N<sub>2</sub> ca. 0 - 3 %, hydroxide H<sub>2</sub> ca. 0 - 1 %, oxygen O<sub>2</sub> ca. 0 - 1 %, hydrogen sulfide H<sub>2</sub>S ca. 0 - 2 %.

In the table 1 the daily quantity of the entry- raw materials and the contribution of the biogas are given.

In the table 2 the contribution of the electricity and the thermal energy is given.

**Table 1.** The contribution of the gas

The daily quantity of the entry- raw materials	t/day	Biogas m <sup>3</sup> /day
The total of the substrata/ biogas	78	10056 m <sup>3</sup> /day

**Table 2.** The contribution of the energy (electricity and thermal energy)

Calculation electricity/ thermal energy	Per day	Per hour
The transmission of the electricity (gross)	25512 kWh	1063kW
The consumption of the electricity for the device cca.	2.041 kWh (8%) from the distributive network	
The transmission of the electricity (net)	23.471kWh	999 kW

**Table 2.** The contribution of the energy (electricity and thermal energy) (continued)

The transmission of the thermal energy (gross)	26.625 kWh	1.103 kW
The transmission of the thermal energy for the device cca.	3.994 kWh	166 kW
The transmission of the thermal energy (net)	22.630 kWh	943kW

Through the fermentation of the raw materials, the decomposition of the organic dry matter from cca. 75 % has taken place. The basic share of the materials (N, P and K) remains equal 1:1 for the close system. Only nitrogen N will be transformed into the more convenient form for plants, but its quantity will not be changed. The stable dung from the biogas device is considered to be convenient for the treatment of the agricultural areas (fields).

The positive characteristics of the stable dung are: good homogeneity, low burden with smell, good hygienic features, the easier availability of the stable dung by the plants because of the effect of the decomposition of the liquid, the ground can easily absorb it, there is no effect of the corrosion of the plants etc.

## **RESULTS AND DISCUSSION**

### **The technical description of the system of the device**

The technological parts of the device are:

- The mixing hole Ø11 m, h=4,5 m, V=330 m<sup>3</sup>,
- The equipment in the station of the pump
- The fermenter Ø26 m, h=8 m, V=3850 m<sup>3</sup>,
- The post fermenter-fermenter II Ø26m, h=8m, V=3850m<sup>3</sup>,
- The CHP-Unit in the container 16,50m x 3,0m, H=3 m,
- Others (the torch, the tubes for the liquid, the tubes for the gas and etc.)

In the mixing hole the daily necessary quantity of the corn silage, the stable dung of the cow with the mat with, if it is needed, the addition of the corn- leftovers, is prepared, it is mixed and the homogeneous mixture (with cca. 11 % of the dry matter) is gotten. The fermenter is constantly feeding itself from the mixing hole with the appropriate quantity of the mixture which is divided into two hourly doses. In the mixing hole the insufficiently high temperature is maintained, so the environment is inconvenient for the process of the fermentation of the raw material and for the production of the biogas. The condensate has been pumped into in the mixing hole from the main gas tube, from the condensation- hole, and after that, it comes back into the process. The quantities of the drained juice from the storage for the silage which have been made, as well as the part of the quantities from the rain from the manipulative surfaces of the roads will be gathered in the collective hole, and then they will be pumped into the final storage (the lagoon with the plastic foil) from which in the next step they will be used as the liquid for the recirculation. From the storage of the silage, a certain quantity of the raw material which is added into the mixing hole is taken at the daily basis. These raw materials are pumped from the mixing hole through the central station into the fermenter. The liquid raw material is pumped out from the fermenter onto the separator where the solid leftover is separated and stored on the plateau, while the liquid phase is led towards the final storage – the lagoon.

Inside the fermenter the constant temperature of 38°C is maintained (with the thermal energy which was gotten in the CHP – unit), at which the colonies of the bacteria will be made and multiplied, which, due to the anaerobic environment, cause the fermentation by developing the biogas. In order for the losses of the thermal energy from the fermenter to be low, the walls of the fermenter are coated with the insulation. In the fermenters, 3 deluged mixers and 3 mixers of the second level are installed. The final storage has the function of storing the fermented liquid raw material after the separation in which the important making of the biogas is not expected. The fermenter is covered with the double foil- reservoir (the membrane) for the biogas, which equals the different quantity of the production of

the gas and which, at the same time, serves as the reservoir for the gas. The double-membrane reservoir consists of the external foil with the protection from the wind, which is resistant to weather conditions (the storm, sun, rain and snow) and from one internal foil which is the reservoir for the gas. With the under-structure; the concrete wall with the belts and knitted network which prevents that the gas reservoir falls into the liquid. Two tubes for the gas lead from the fermenter through the hole for the condensate towards the unit CHP. In the hole, which is protected from the frost, the condensate is separated from the tubes (the biogas does not come out). That concrete hole is exposed to radiation by one tube which is made from the stainless steel, minimally 3 m above the condensate hole.

In front of the cogeneration module for the production of the electricity and thermal energy into the CHP the main hand- valve for the biogas and the main magnetic valve for the biogas which can stop the supply of the gas into the CHP-space (container) are installed. The compressor for the gas (the blow-pipe) drains the biogas from the reservoir for the gas and compresses that biogas at 130 mbar in front of the entrance into the CHP. The biogas flows through the valve into the regulation-block of the supplier of the CHP. The mixing of the biogas with the air takes place in the CHP and finally the combustion, too. In that conveying, through the motor, the generator which delivers the electricity into the public power-supply network is put into operation. In the case of the servicing of the CHP unit, the biogas is burnt down in a controlled manner through the torch for the biogas which is installed near the CHP container. The valve for above- and under-pressure in the reservoir for the biogas, and the vents of the biogas above the fermenter from which the biogas can be vented into the air, are controlled last.

### **The scheme of the flow of the liquid substrata (raw materials)**

The corn silage, and the cow- stable dung with the straw are dosed into the mixing holes by the loading machine. In that case 30,1 [t/d] of the corn silage, ~16,4[t/d] of the cow- stable dung with the straw- mat, and 31,5 [t/d] of the Sudanese grass are added into the mixing hole. The approximate quantity in the dosing spoon is 1,5t, which means that 65 drives per day of 5 min/drive = 5,5 hours per day for the filling of the new raw material are needed. That solid part of the raw materials is mixed in the mixing hole (the liquid from the separation and/or recirculation), then the mixed mass, through the tube and the pump- station, is dosed into the fermenter until 25% of the fresh mass.

In the pump station, two pumps are designed: one for the process  $V=20\text{m}^3/\text{h}$  bis  $65\text{m}^3/\text{h}$  15 kW el. (regulated by the frequency), one pump for the separation and lagoon  $V=20\text{m}^3/\text{h}$  bis  $65\text{m}^3/\text{h}$  15 kW el. (regulated by the frequency).

Two pumps for the delivering of the mixed raw material with the share until 11% of the dry matter, for the dosing of the fermenter.

The fermenter is the gas- impermeable concrete armored reservoir which is insulated and equipped with six mixers for preventing the floating or sedimentary layers caused through the big part of the dry matter. The liquid is warmed up with the installed heaters in the reservoir on the wall and it is constantly kept at the temperature of 38°C. The theoretical limit of the duration of the fermentation is 60 days. From the dosing hole, the fermenter will be dosed by the given quantity of the fresh raw material of  $5\text{m}^3/\text{h}$  -  $10\text{m}^3/\text{h}$ , which is divided into 22h/day.

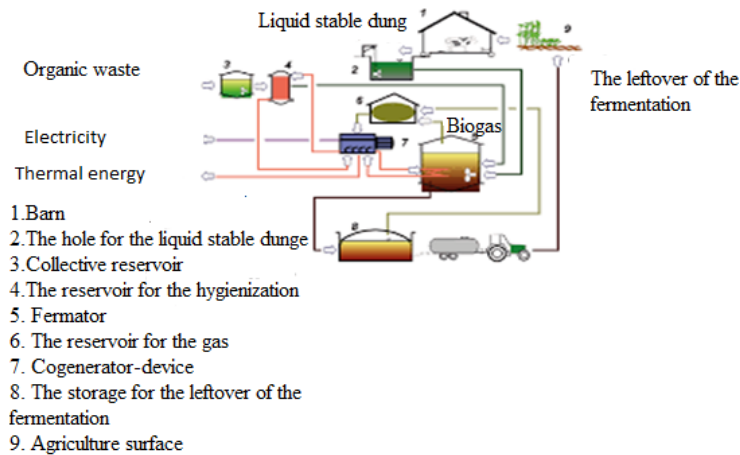
In the fermenters, the raw material is further fermented. Then, the decomposed material from the fermenter is pumped towards the separation which divides the solid and liquid content of the raw material from the fermentation. After the separation the dry leftover is stored on the concrete plateau of the device. The liquid part flows into the final storage (the lagoon with the plastic foil) and it is used for the recirculation.

In the figure 1 the scheme of the flow of the substratum is presented.

### **The flow of the biogas**

The biogas is made in the fermenter in which there is the reservoir for the biogas. The reservoir serves as the compensation of the production of the biogas and the stoppage on the power station (for example, the servicing of the CHP-unit). The biogas will be pulled from the storage sphere through the tube for the biogas towards the hole for the con dens. through the equipment for the biogas, with the compressor which will compress the biogas on cca. 130 mbar and carry it through the regulatory block

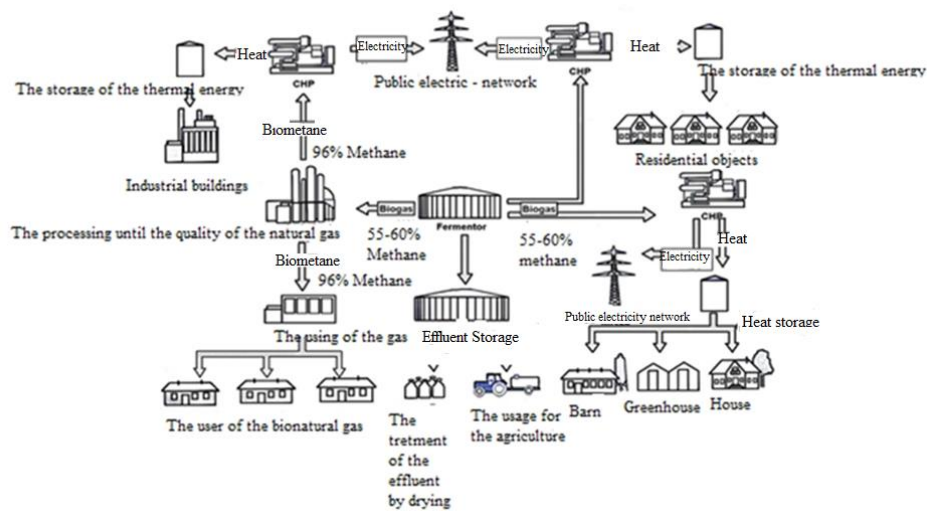
towards the CHP-unit. The calculated flow for the compressor is cca. 550m<sup>3</sup>/h per compressor (CHP unit).



**Fig. 1.** The scheme of the flow of the substratum

The CHP-unit contains gross power of 1.063 kW el. and the thermal gross power of 1.103kW th. In the case of the stoppage of the CHP-unit, the membrane in the reservoir for the gas is raised until certain height (the limited height according to the recommendations), after which, the torch is turned on and the gas is burnt in a controlled manner. The torch is automatically turned on or off, with the external signal, (CHP-stands, the reservoir for the gas comes to the level of > 95%), that is, along the level of the container. The torch is a peak consumer of the biogas which is, with the construction and the cable, connected near the CHP- unit.

In the figure 2, the scheme of the flow of the biogas is presented.



**Fig. 2.** The scheme of the flow of the biogas.

The electricity of the CHP unit which is produced and taken away from the generator, is transformed through the cabinet of the transformer station into the transformer and through it, it is given to the local power-supply distributor. The needs of the electricity for the device (the pumps, mixers, etc. use 6-8% of the total electrical power of the device) are taken from the power-supply network.

In the controlling object there is the room for the electrical engineering (the cabinet for the power-supply, the cabinet for the management, etc.), which can be operated by remote control, by the modem and the computer.

The thermal energy is made on one side through the cooling of the motor and on the other side through the using of the thermal energy from the waste hot gases. The thermal energy from the waste gases can be sent towards the production of the vapor or into the air, by bypass. In the case that during the summer, the need of the thermal energy is reduced, the rest of the thermal energy will be separated through the cooler of the motor which is on the ceiling of the CHP- container. The waste thermal energy is used for the heating of the processes in the fermenters.

### The CHP device

With the cogeneration or the CHP device with the using of the gas motors, the gas internal-combustion engine is harnessed with the generator for the production of the electricity, and the waste thermal energy is used for the production of the thermal energy (hot water, or vapor). The scheme of the harnessing of the motor with the users of the thermal energy is shown in the picture 3. In the picture 3 the CHP device with the production of the hot water and vapor is shown. The hot water is sent there to the consumers through the heat exchanger which is turned on into the circle of the cooling of the motor and the temperature of the exit which is approximately 80 °C, and the vapor is produced by using the waste thermal energy of the smoke- gases which have the temperatures at the exit from the motor 450-480 °C.

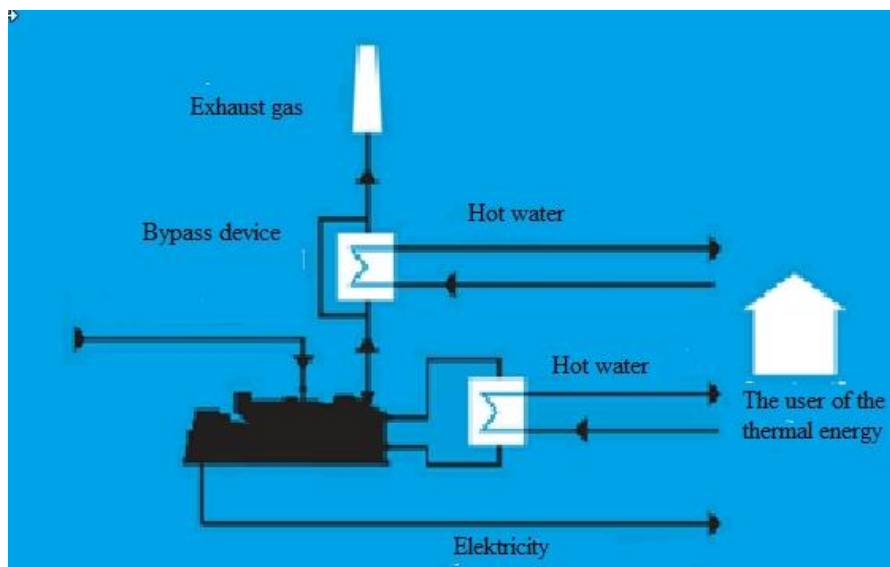


Fig. 3. Cogeneration in the industry by using of the gas motors

If the hot water of the higher temperatures is needed, instead of the boiler of the utilizator for the production of the vapor, the second heat exchanger is installed (exhaust gases and water), and the cooling liquid at the exit of the motor is additionally heated first in that exchanger until the needed temperature, and then, through the special exchanger the hot water is heated (90/70 °C, or 100/70 °C), which is sent to the users. The CHP device with two motors includes the peak boiler for the heating of the water and the buffer for the accumulation of the thermal energy, if the needs of the users are changeable during the day – when the needs of the users are lower than the thermal energy which is given by the motors, the buffer accumulates the thermal energy, and in the second period is used as the additional source of the thermal energy. The CHP device can follow the need for the electricity (“the regime of the following the electricity”), and the thermal energy is the by-product. In this way, the quantity of the thermal energy which is taken over from the network is minimized. If the need of the thermal energy is higher than the produced one, the boiler is turned on, in order for it to fulfill that quantity of the thermal energy which is missing. If the need of the users is lower than the one which is currently produced in the CHP, the part of the thermal energy is thrown away through the refrigerator of the CHP into the atmosphere.

This is disadvantageous as far as the effectiveness of the CHP device is concerned and for the thermal energy which is thrown into the atmosphere to be minimized, the storage battery of the thermal energy in which the thermal energy is accumulated in the period of the low need for the thermal energy (mainly during the night), can be used, and the accumulated thermal energy is delivered to the users in the period when the needs for the thermal energy of the technological users are big (usually the first shift). In contrast, if the needs for the thermal energy are followed (“the regime of the following the thermal energy”), or the imperative is the maximal effectiveness of the device (without throwing the excess energy), that quantity of the energy which suits the needs in the thermal energy is produced. The thermal energy which is produced covers the needs of the users of the electricity, and if they are lower than the production, the part of the electricity is delivered to the power-supply network. If the needs of the consumers of the electricity are higher than the production of the CHP device, the shortage is filled up from the network. The constant work of the motor at maximal power is possible, regardless of the needs of the thermal energy. It is used in the case when the price of the electricity which is paid by the consumer, is so high that it compensates the price of the fuel, or if there is the reasonable price which the consumer gets for the electricity which is delivered, in relation to the price of the fuel.

If the reasonable price is made through the privileged charge, then, the condition that the total annual level of the usefulness has to be bigger than the required one for getting the privileged charge, should usually be met, too. In that case, the CHP device can be combined with the storage battery of the thermal energy which is used in the periods of the year when there is the low consumption of the thermal energy.

In the case that the privileged charge for the electricity which is delivered is not implemented, then the imperative is that the thermal energy of the CHP device should be maximally used, because there is the big danger that the CHP does not work cost-effectively, that is, that the power of the device is not chosen well. It depends on the price of the fuel and the electricity which is paid by the consumer.

## **CONCLUSION**

It can be concluded that the energetic effectiveness of this device is significantly higher than with the supplying of an industrial consumer with the electricity from the network, and with the thermal energy from the factory- boiler. The problem with the estimation of the profitability of the usage of this device is that, that in the industrial consumer itself, more fuel is used for the usage of this device than for the supplying with the thermal energy from the factory- boiler-room and from the power-supply network. Then the parity of the price and the electricity and the level of the sale of the thermal energy, as it is shown in the paper, define the profitability of the device. The careful technical analysis of the consumer and the energetic system and the financial analysis of the chosen case, have to precede the final decision about the purchase and the usage of the CHP device.

Because of the failure which was noticed during the practical work, this paper had the aim of pointing out to the basic problems with the choice of the power and the way of work of these devices.

## **REFERENCES**

- [1] Nayal F.S., Mammadov A., Ciliz N., Environmental assessment of energy generation from agricultural and farm waste through anaerobic digestion, *Journal of Environmental Management*, 184, pp. 389-399, 2016.
- [2] Markou G., Brulé M., Balafoutis A., (...), Georgakakis D., Papadakis, G., Biogas production from energy crops in northern Greece: economics of electricity generation associated with heat recovery in a greenhouse, *Clean Technologies and Environmental Policy*, 9(4), pp. 1147-1167, 2017.
- [3] Manganelli B., Economic feasibility of a biogas cogeneration plant fueled with biogas from animal waste, *Advanced Materials Research*, 864-867, pp. 451-455, 2014.
- [4] Methling T., Armbrust N., Haitz, T., (...), Riedel U., Scheffknecht G.: Power generation based on biomass by combined fermentation and gasification - A new concept derived from experiments and modelling, *Bioresource Technology*, 169, pp. 510-517, 2014.

- [5] Prakash M., Sarkar A., Sarkar J., Mondal S.S., Chakraborty J.P., Proposal and design of a new biomass based syngas production system integrated with combined heat and power generation, *Energy*, 133, pp. 986-997, 2017.
- [6] Kgomo, J., Ngobeni, A., Lencwe, M., Chowdhury, S.P.D. (2019). Design of Combined Heat and Power for Waste Water Treatment Plant, 2019 10th International Renewable Energy Congress, IREC 2019. 8754637 DOI: 10.1109/IREC.2019.8754637, 2019.
- [7] Kaparaju, P., Rintala, J., Generation of heat and power from biogas for stationary applications: Boilers, gas engines and turbines, combined heat and power (CHP) plants and fuel cells ( Book Chapter) *The Biogas Handbook: Science, Production and Applications*, pp. 404-427 2013. DOI: 10.1533/9780857097415.3.404
- [8] Kluczek, A., Dynamic energy LCA-based assessment approach to evaluate energy intensity and related impact for the biogas CHP plant as the basis of the environmental view of sustainability, *Procedia Manufacturing*, 21, pp. 297-304, 2018.
- [9] Milani M., Montorsi I., Stefani M., An integrated approach to energy recovery from biomass and waste: Anaerobic digestion-gasification-water treatment, *Waste Management and Research*, 32( 7), pp. 614-625, 2014.
- [10] Pérez, V., Lebrero, R., Muñoz, R., Comparative Evaluation of Biogas Valorization into Electricity/Heat and Poly(hydroxyalkanoates) in Waste Treatment Plants: Assessing the Influence of Local Commodity Prices and Current Biotechnological Limitations, *ACS Sustainable Chemistry and Engineering*, 8(20), pp. 7701-7709, 2020.
- [11] Prakash, M., Sarkar, A., Sarkar, J., Mondal, S.S., Chakraborty, J.P., Proposal and design of a new biomass based syngas production system integrated with combined heat and power generation, *Energy*, 133, pp. 986-997, 2017.
- [12] Alder M.A., Use of Bio-gas for power Generation, *Water and Environment Journal*, 1(3), pp. 271-277, 1987.
- [13] Abusoglu A., Anvari – Moghaddam A., Guerrero J.M, Producing bio-electricity and bio-heat from urban sewage sludge in Turkey using a two-stage process, 5th International Conference on Power Generation Systems and Renewable Energy Technologies, Istanbul, August 26/27, , pp. 302-306, 2019.
- [14] Lantz, M. : The economic performance of combined heat and power from biogas produced from manure in Sweden - A comparison of different CHP technologies, *Applied Energy*, 98, pp. 502-511, 2012.
- [15] Achinas S., Martherus D., Krooneman J., Euverink, G. J.W., Preliminary assessment of a biogas-based power plant from organic waste in the North Netherlands, *Energies*, 12, No 21, pp.122-140, 2019.



## ADVANTAGES OF BIOGAS POWER PLANTS IN ENERGY TRANSITION OF PANNONIAN COUNTRIES (1) - Benefits for the local community

Milan Ivanović<sup>1</sup>, Hrvoje Glavaš<sup>2</sup>

<sup>1</sup> Panon – think tank for strategic studies, Osijek, Croatia

<sup>2</sup> Josip Juraj Strossmayer University of Osijek, Faculty of Electrical Engineering,  
Computer Science and Information Technology, Osijek, Croatia  
e-mail: [milanivanovi4@gmail.com](mailto:milanivanovi4@gmail.com)

**Abstract:** This paper points out the benefits for the local community from the construction of biogas power plants (BgP) - which are not from using other renewable energy sources. Benefits from BgP for local community are: additional income to local farmers, higher level of agro technologies in the village, strengthening social cohesion, ecological disposal of rural waste, electricity and heat production, organic fertilizer, hiring local labor and better quality of life for all inhabitants. In paper presented and important elements for planning the construction of biogas power plants.

**Key words:** Biogas power plants, Energy transition, Local community, Renewable energy sources, Smart village

### INTRODUCTORY NOTE

The energy transition is a pathway toward transformation of the global energy sector from fossil-based to zero-carbon by the second half of this century. At its heart is the need to reduce energy-related CO<sub>2</sub> emissions to limit climate change. Renewable energy and energy efficiency measures can potentially achieve 90% of the required carbon reductions. [1]

Biogas plants are not adequately represented in the energy transition plans of the new EU members, nor in the EU candidate countries. Stakeholders for wind and solar power plants strongly influence decision makers in the investment policy in the energy sector through (in) transparent processes. Intensified construction of wind farms and large solar systems in the Pannonian countries is essentially detrimental to many local communities and the national economy and energy transition of these countries - because national credit lines, RES funds and preferential tariffs are used; all of which minimizes investment in other renewable energy.

On the other hand, biogas plants (BgP) - which do not have structured interest groups (because there are not so many opportunities to earn without work in this sector) are unfairly neglected - are put in the background. This paper therefore points to the advantages of biogas power plants - particularly important for villages in Pannonia - a natural area for biogas power plants in rural areas. In addition, the Pannonia areas have problems with: unfavorable demographic trends, insufficient economic development based on agriculture, and an unfavorable situation with local waste management.

Research data, as well as the work of members of Panon think tank Osijek show that biogas plants have the most favorable effects on the development of rural local communities and the GDP of the national economy - through investment, intermediate consumption and employment of domestic labor and putting into service national resources. This will be illustrated by the example of the Republic of Croatia. [2] [3] [4] [5] [6]

The benefits of biogas power plants are multiple for both the local community and the national economy. From this title, this analysis is conducted on two levels: local and national.

### BENEFITS OF BIOGAS POWER PLANTS FOR THE LOCAL COMMUNITY

The construction of biogas power plants contributes to a number of local development goals; raising the standard of living and quality of life in villages, raising the organizational and technological level of life and business in villages, employment of young people and other benefits - as shown in Figure 1.

Biogas is produced in rural areas from poultry manure and livestock excrement, biodegradable kitchen waste and green biomass (vegetable waste and silage). In urban areas, it is also produced from sewage sludge and biodegradable municipal waste.

So the benefits to the local community are:

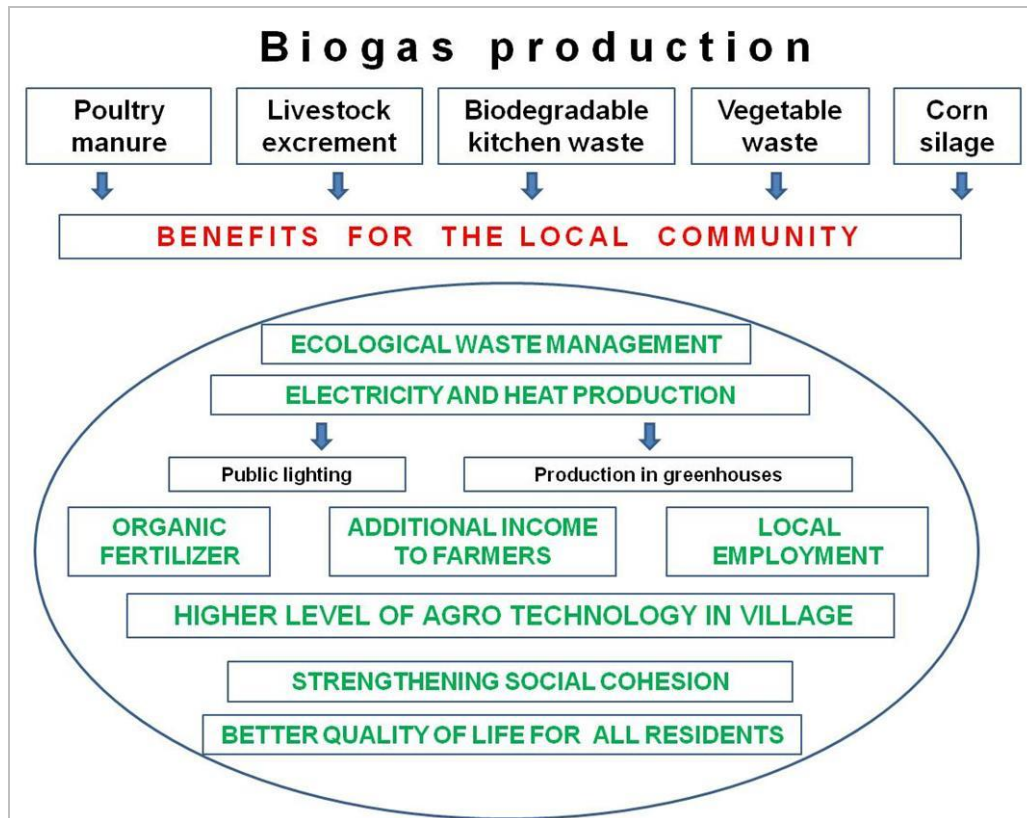


Fig. 1. Benefits to the local community from the construction of biogas power plants

### Ecological disposal of rural waste

In most rural areas, the ecological disposal of waste from rural production (poultry manure and livestock excrement) and bio-degradable kitchen waste has not been effectively addressed. Rural households solve this traditionally - by disposing of their property. A small number of rural households, which own a larger number of livestock, dispose of livestock manure in their backyards - in their private compost bins and, later, use this organic fertilizer on their arable land. However, such a traditional method is not sanitary (stench, rats, insects, pigs, poultry, etc.) and endangers the quality of life of owners and neighbors and emits greenhouse gases (methane, etc.). In contrast, transporting such waste to a local biogas plant is a much more efficient way of disposing of rural waste.

### Electricity and heat production

Biogas power plants produce electricity that can be: (a) delivered to the national electricity system - for a fee (if there is a contract and the BgP is connected to the electricity grid) or (b) used locally - for public lighting, local water supply, for communal, social or educational facilities. E.g. many rural municipalities in the area of Slavonia and Baranja have problems with the financing of public lighting, and in many villages of these municipalities the public lighting is turned off after midnight. Therefore, with the construction of BgP, it is possible to solve the local electricity supply of communal facilities. In the process of electricity production in BgP, waste heat is generated which can be used for heating business and social spaces, for drying agricultural products or for heating greenhouses and hothouses. E.g. in the area of Slavonia and Baranja, several biogas power plants supply heat for the hydroponic

production of tomatoes in greenhouses (on 4 ha in Kneževi Vinogradi) or for the production of vegetables and flowers in greenhouses (in village Ivankovo and Tomašanci). [3]

### **Additional income to local farmers**

For the operation of BgP in the fermenter - in addition to livestock manure and organic kitchen waste - green biomass (vegetable waste and corn silage) is used in the amount of 40 to 60 percent in each cycle of BgP - which lasts about 29 days. This means that it is necessary to deliver tens of tons of silage for each cycle of BgP operation - depending on the installed BgP capacity and the model of structuring the input raw materials. In this way, local farmers earn additional income, because - silage is the calculated input cost in the production of BgP.

### **Organic fertilizer**

At the end of each BgP cycle (depending on the installed capacity), tens of tons of digestate remain - a high-quality organic fertilizer - which is used to fertilize agricultural land or is commercially packaged and sold in retail chains. It should be noted that according to the quantities of waste delivered (after the completion of the cycle in BgP) each local supplier of livestock manure receives the appropriate amount of digestate for use on their agricultural land; e.g. as it is applied in the municipal BgP (power 2 MW) in Dunaujvaros, Hungary.

### **Hiring local labor**

Given the significant share of construction work in the construction of BgP - there is a high probability that for several dozen local construction workers there will be work from one to two years - depending on the installed capacity of BgP.

When the BgP construction is completed, the BgP crew is hired - which is not numerous - from 3 to 5 employees with secondary technical education and one engineer? The importance of employing local technical staff should be pointed out here - which at the same time contributes to a higher level of technical competence of the local community.

### **Higher level of agro technologies in the village**

The existence (business) of BgP in each rural community contributes to increasing the level of application of modern agro technologies in the village - as opposed to traditional habits and customs. In this way - a regular rhythm of business is introduced in the village, a certain organization of business and social and business relations is introduced - in the wake of the concept of a smart village.

### **Strengthening social cohesion**

Planning and organization of the implementation of the BgP project and its construction, as well as the functioning of the plant itself, requires the agreement and cooperation of all local private, business and social entities and local self-government bodies. These are often significant challenges in practice, but basically - these processes contribute to strengthening social cohesion in the community; mutual trust of residents, their trust in local authorities and local organization and work on a joint project are strengthened.

### **Better quality of life**

Realization and operation of BgP - ultimately brings a better quality of life for all residents in the village; there are fewer unpleasant odors and stench in the settlement, there is more order and more organized business life, local farmers have additional earnings, part of the local workforce is employed and a higher level of technical and agro culture is achieved in the community.

## PLANNING THE CONSTRUCTION OF BIOGAS POWER PLANTS

Planning the construction of a biogas power plant (location and capacity) starts from local potentials; important are - number of households, number of poultry, number of small livestock (sheep, goats), number of pigs and number of cattle - according to the model shown in Figure 2; i.e. ie a larger number of inhabitants and livestock allows the construction of higher-capacity BgP. The most common built capacities of biogas power plants in developed EU countries are 1 and 2 MW per locations where there is a large livestock production and a larger number of inhabitants, and power plants of lower power (300 to 500 kW) are built in smaller villages.

We also graphically presented the model of financing the construction of BgP (Fig. 3). Large business systems of agricultural production (LBS), national energy efficiency fund (NEEF), national energy market operator (NEMO), large private agricultural producers (LPAP) will participate in financing and crediting the construction of large BgP (1 MW of power and more). In construction of small capacity BgP in addition to the above entities (with a smaller share) will also finance: joint small agricultural producers (JSAP), local government (municipality), individual households in the local community (household) and regional government (county); Figure 3.

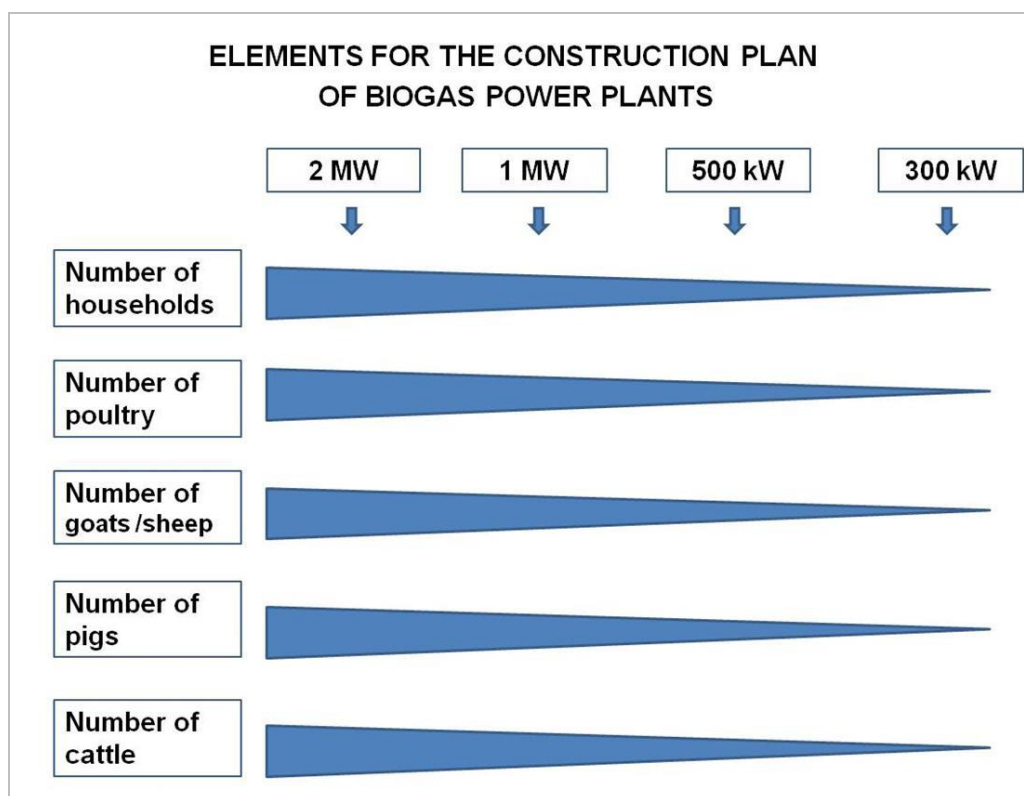
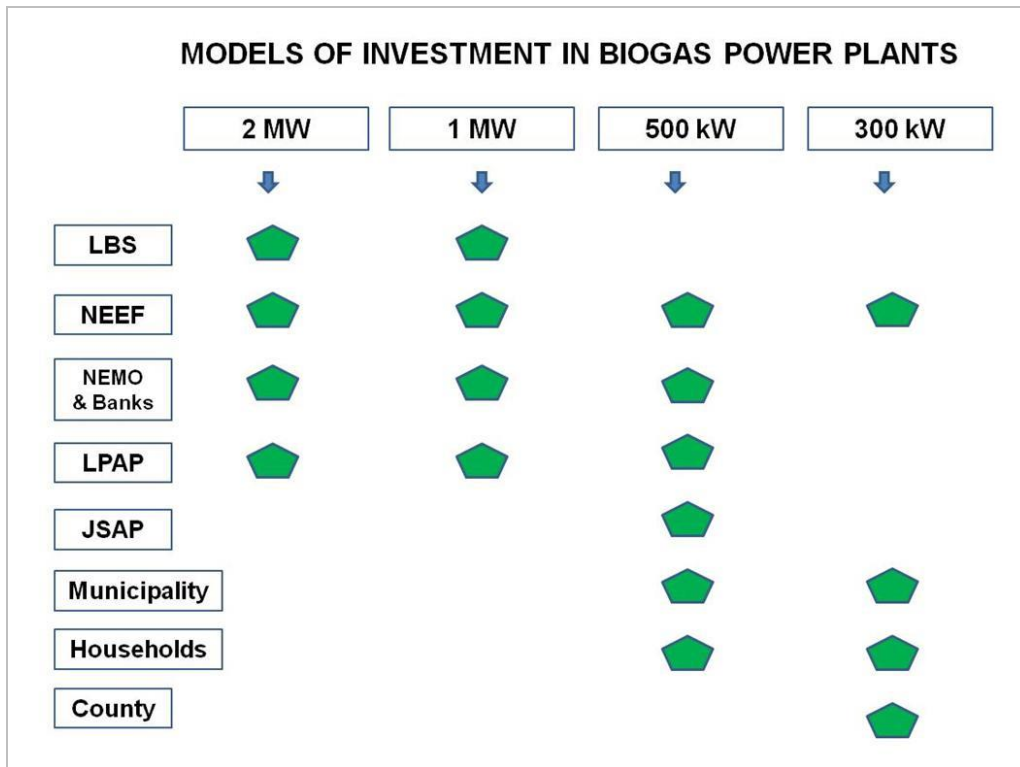


Fig. 2. Elements for planning the construction of biogas power plants

It should be noted here that the first biogas power plant in Croatia was built in 2009 in the agricultural cooperative Osatina near the village of Ivankovo (not far from Vinkovci), and in the following years another 38 biogas plants with a total capacity of 41.7 MWe<sub>el</sub> were built and put into operation; of that number, 24 power plants (installed capacity 29,986 MWe<sub>el</sub> and 30,292 QMW) were built in the Slavonia region (from these 15 BgP was built in the Osijek-Baranja County). It is significant that a large number of these plants in the region were designed, built and put into operation (connection to the power system) by Slavonian experts from Belišće, Osijek, Slatina, Sl. Brod, Vinkovci and Vukovar [4]. Figure 4 shows the newly built BgP (300 kW) in Hrastin village (about 20 km from Osijek) and Figure 5 shows the locations of the built BgP in the region of Slavonia until the end 2019.



**Fig. 3.** Investment models in biogas power plants

It should be noted here that the first biogas power plant in Croatia was built in 2009 in the agricultural cooperative Osatina near the village of Ivankovo (not far from Vinkovci), and in the following years another 38 biogas plants with a total capacity of 41.7 MWe<sub>el</sub> were built and put into operation; of that number, 24 power plants (Installed capacity 29,986 MWe<sub>el</sub> and 30,292 QMW) were built in the Slavonia region, and 15 BpE was built in the Osijek-Baranja County. It is significant that a large number of these plants in the region were designed, built and put into operation (connection to the power system) by Slavonian experts from Belišće, Osijek, Slatina, Sl. Brod, Vinkovci and Vukovar [5]. Figure 4 shows the newly built BpE (300 kW) in the Hrastin village - about 20 km from Osijek and Figure 5 shows the locations of the built BgP in the Slavonia region.



**Fig. 4.** Biogas power plant (300 kW) in the Hrastin village



**Fig. 5.** Locations of biogas power plants in the area of Slavonia and Baranja region (as of 2019)

## CONCLUSION

The construction of biogas power plants in rural areas of the Pannonian countries contributes to a number of local development goals;

- Raising the standard of living and quality of life in the village,
- Possibility of additional earnings for local farmers,
- Ecological disposal of livestock and rural waste,
- Raising the organizational and technological level of business in the village,
- Youth employment and
- Raising social cohesion in the village.

In this paper, models for decision-making and construction of BgP are also proposed.

Examples from rural areas of Austria, Croatia and Hungary prove the importance and benefits of building biogas plants.

## REFERENCES

- [1] The International Renewable Energy Agency (IRENA): Energy Transition
- [2] <https://www.irena.org/energytransition>
- [3] Glavaš, H.; Ivanović, M.; Mandić, N.: Resources and Possibilities of Agro Biomass Usage for Energy Purposes in Slavonia region (Croatia), ENERGYCON 2014; IEEE, Dubrovnik, Croatia 13-16 May, 2014; Proceedings pp 4.1 – 6
- [4] Ivanović, M.; Glavaš, H.; Vukobratović, M.: - Bioplinne elektrane u Slavoniji i Baranji, 15. skup o prirodnom plinu, toplini i vodi, Osijek, 27.-29.09.2017. Proceedings, pp 204-215
- [5] Ivanović, Milan - Komunalno zbrinjavanje otpada – stanje u gradovima slavonske regije; 28<sup>th</sup> International Conference OTO 2019. Vinkovci, Decembre 12, 2019; Panon think tank Osijek, Proceedings, pp 163-172
- [6] Ivanović, Milan - Kružna ekonomija i bioplinne elektrane u Slavoniji i Baranji; 35. Međunarodni znanstveno-stručni susret stručnjaka za plin, October 21 – 23, 2020., Proceedings, pp 225-235
- [7] Ivanović, Milan - Bioplin u kružnoj ekonomiji Europske Unije; 35. Međunarodni znanstveno-stručni susret stručnjaka za plin, October 21 – 23, 2020, Proceedings, pp 236-247  
<https://www.researchgate.net/publication/344905290>

## **ADVANTAGES OF BIOGAS POWER PLANTS IN ENERGY TRANSITION OF PANNONIAN COUNTRIES (2) - Benefits for the national economy**

**Milan Ivanović<sup>1</sup>, Hrvoje Glavaš<sup>2</sup>**

<sup>1</sup>Panon – think tank for strategic studies, Osijek, Croatia

<sup>2</sup>Josip Juraj Strossmayer University of Osijek, Faculty of Electrical Engineering, Computer Science and Information Technology, Osijek, Croatia  
e-mail: [milanivanovi4@gmail.com](mailto:milanivanovi4@gmail.com)

**Abstract:** This paper points out benefits for the national economy from construction of biogas plants (BgP) - especially important for countries of the Pannonia Plain. Research data show that BgP has the most favorable effects on GDP of the national economy - compared to other renewable sources. Benefits from BgP for the national economy are: reducing CO<sub>2</sub> emissions and municipal waste disposing, fewer imports of electricity, gas, and oil, significantly better economic performance in energy sector, balancing functioning of the national electricity system, hiring domestic companies and activating domestic resources and use of biogas in transport.

**Key words:** Biogas power plants, Energy transition, National economy, Pannonian countries, Renewable energy sources

### **INTRODUCTORY NOTE**

In the paper “Advantages of biogas power plants in energy transition Pannonia countries - Benefits for the local community” we pointed out the unfavorable position of biogas power plants (BgP) in government structures (stronger interest groups for wind and solar power plants) and the benefits of the local community from the construction of BgP. In this paper we pointed out benefits to the national economy - especially important for the countries of the Pannonian Plain. Research data show that BgP has the most favorable effects on the GDP of the national economy - compared to other renewable sources - through investment, intermediate consumption and employment of domestic labor and the activation of national resources. This will be illustrated by the example of the Republic of Croatia. [1-5].

### **BENEFITS OF BIOGAS POWER PLANTS FOR THE NATIONAL ECONOMY**

The national economy and energy sector have a number of very significant benefits from investing in the construction of biogas plants compared to other renewable sources - as shown in Figure 2.

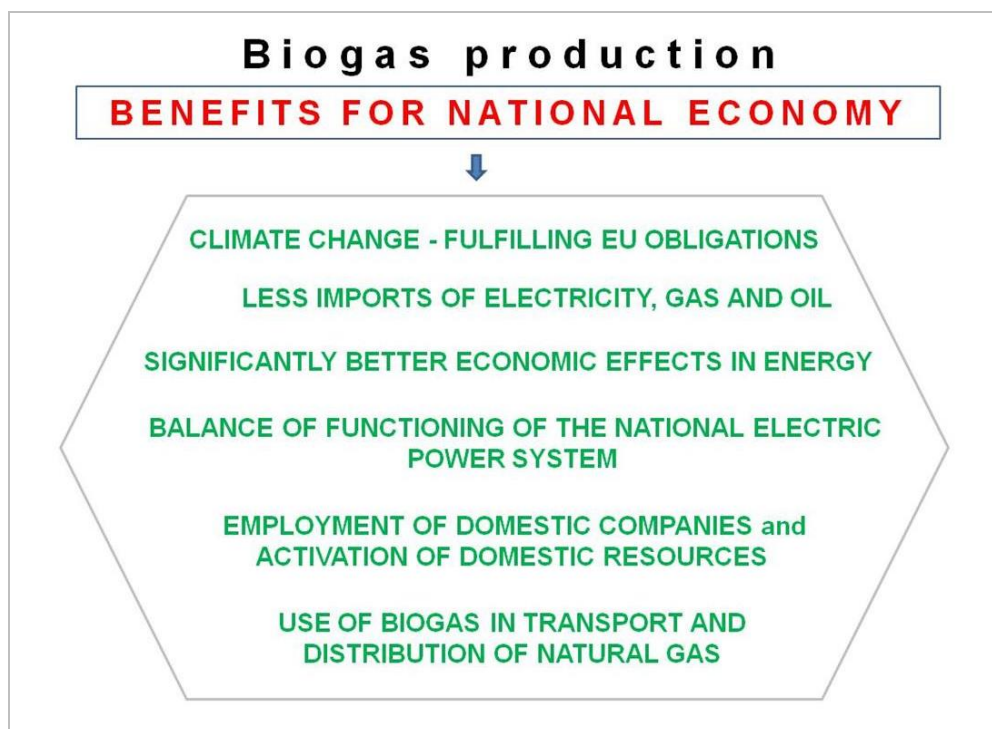
#### **Climate change - meeting EU obligations**

Each EU member state has committed itself to reducing CO<sub>2</sub> emissions and disposing of municipal waste, in order to mitigate climate change. It should be emphasized here that these are not unimportant and only formal obligations imposed from above - but a civilization and planetary obligation to prevent catastrophes for humanity. As much as wind and solar power plants are neutral in terms of greenhouse gas emissions, so is the disposal of livestock manure in BgP - especially in cattle breeding due to methane emissions. There is special issue of disposal, i.e. recycling of municipal waste; e.g. Croatia should have separated and recycled 50% of municipal waste by 2020. But this has not been achieved; the rate of separate collection of municipal waste in Croatia in 2020 was 41%. According to the current practice Croatia will pay penalties until the assumed obligations are fulfilled as paid by Bulgaria, Greece, Hungary, Italy and Poland (about ten million € per quarter). [3]

#### **Fewer imports of electricity, gas, and oil**

The production and use of biogas contribute to the reduction of imports of fossil fuels. E.g. in the last 10 years, the Republic of Croatia has imported between 30 and 40% of electricity and the same

amount of natural gas. A significant increase in the production of biogas and electricity from BgP has a positive impact on reducing national energy dependence, i.e. reducing import of these energy sources. [4]



**Fig. 1.** Benefits to the national economy from the construction of biogas power plants

### Significantly better economic performance in energy

The largest impact on GDP and employment in Croatia among renewable energy sources (RES) is achieved by GDP; as shown in Tables 1 and 2. Also - with BgP, investments per MW in electric power plants are lower.

**Table 1.** Investment channels - effects on € 1 million value of total investments

Indicator	Power plant type	Wind farms	Solar	Biomass	<b>Biogas</b>	Small hydropower
GDP (000 €)						
Direct effect		739,1	973,6	188,9	<b>215,8</b>	916,3
Indirect effect		193,3	17,5	671,5	<b>608,0</b>	73,3
Induced effect		91,0	7,4	336,5	<b>183,5</b>	35,3
Total effect		1023,3	998,6	1197,0	<b>1007,3</b>	1025,0
Number of employees in terms of annual labor input						
Direct effect		0,6	0	11,7	<b>8,6</b>	6,0
Indirect effect		6,5	0,5	37,8	<b>33,3</b>	2,5
Induced effect		3,6	0,3	13,1	<b>7,2</b>	1,4
Total effect		10,7	0,7	62,7	<b>49,1</b>	9,8

Source: [6]



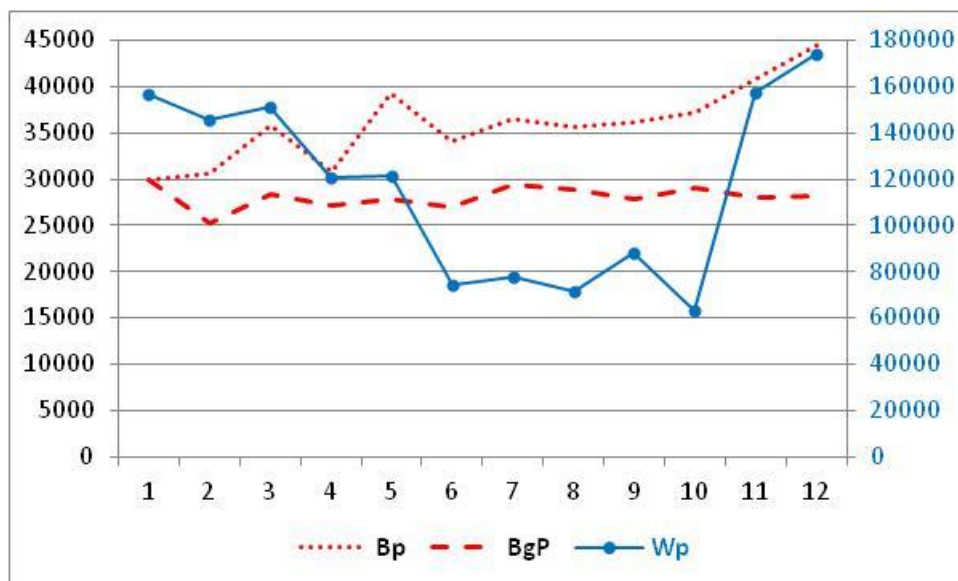
**Table 2.** Intermediate consumption channel - effects on € 1 million value of total investments

Indicator	Power plant type	Wind farms	Solar	Biomass	Biogas	Small hydropower
GDP (000 €)						
Direct effect		130,0	238,4	217,1	<b>240,9</b>	235,9
Indirect effect		94,2	181,0	178,1	<b>212,9</b>	200,6
Induced effect		120,5	216,9	199,9	<b>220,3</b>	210,7
Total effect		344,6	636,3	595,1	<b>674,1</b>	647,3
Number of employees in terms of annual labor input						
Direct effect		6,1	8,2	9,8	<b>11,9</b>	11,6
Indirect effect		3,2	6,5	6,5	<b>6,6</b>	6,1
Induced effect		5,0	8,5	8,6	<b>9,0</b>	8,3
Total effect		14,3	23,2	24,9	<b>27,5</b>	26,0

Source: [6]

### Balancing the functioning of the national electricity system

Biogas plants do not have daily and seasonal oscillations in production - such as hydro, solar and wind power - which contributes to balancing the functioning of the country's electricity system. E.g. Figures 2 and 3 show the monthly oscillations in the production of electricity in the power system of the Republic of Croatia from renewable energy sources. Balanced production of BgP and biomass power plants (Bp) is observed in contrast to wind power plants (Wp) and solar power plants (Sp).



**Fig. 2.** Production of electricity from renewable energy sources in Croatia in 2019 - by months [7]

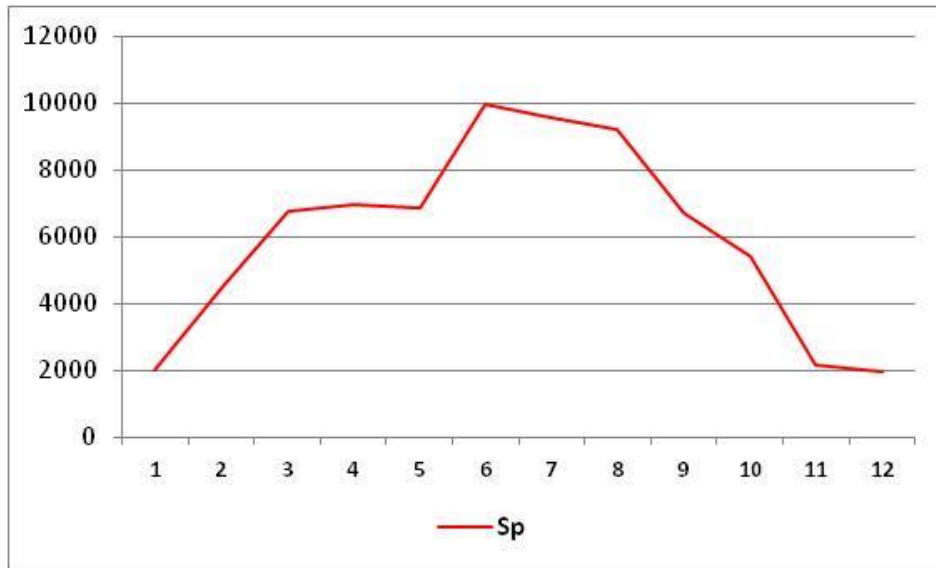


Fig. 3. Production of electricity from solar power plants in Croatia in 2019 - by months [7]

### Hiring domestic companies and activating domestic resources

Data on investments in renewable and energy sources in Croatia in the period from 2009 to 2016 show that about 80% of the total investment costs in biogas plants are realized by the domestic economy, unlike wind farms and other technologies where imports of equipment and materials and foreign costs h contractors amount to over 80 percent. Figure 4 shows the BgP complex (2 MW) "Biointegra" Slatina - built by domestic contractors with domestic construction materials and a significant part of domestic equipment.



Fig. 4. Biogas power plants (2 MW) "Biointegra" Slatina, Croatia [8]

## Use of biogas in transport and distribution of natural gas

Finished biogas (biomethane) in developed EU countries has been used for years as a fuel in road transport or as a supplement in the distribution of natural gas. To use biogas as a fuel for road vehicles or in the natural gas distribution network, additional processing is needed - removal of CO<sub>2</sub> and sulfur. The treated biogas (now biomethane) is compressed to the gas network pressure level and can be placed in the natural gas network distribution system. In the developed European countries, in the past decade, there has been strong growth in the construction of biogas capacity and the use of biogas, and especially strong growth in the capacity for biogas refining, i.e. biomethane production; Figure 5 shows the annual growth rates of the number of biogas and biomethane plants in Europe. [9][10]

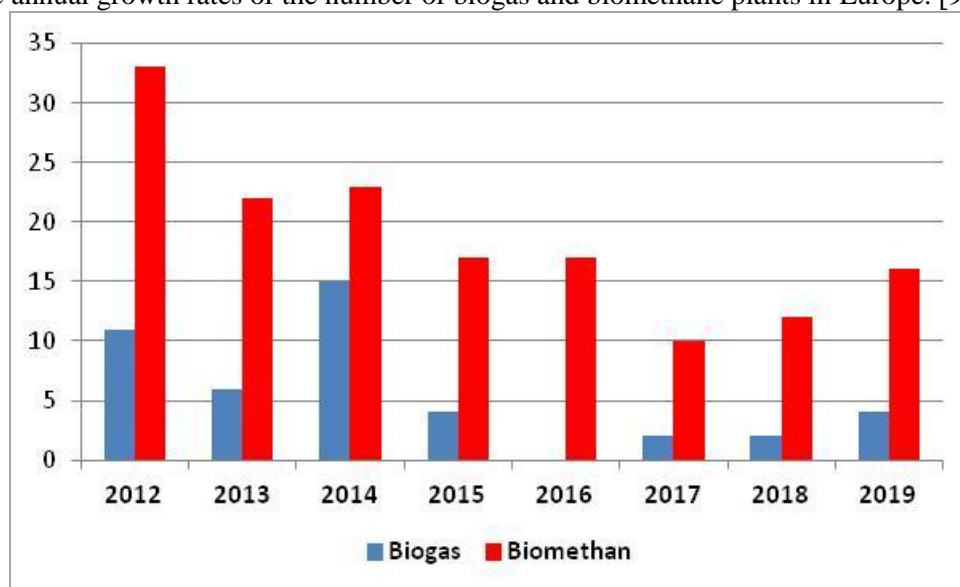


Fig. 5. Annual growth rates of biogas and biomethane plants in Europe (%) [10]

Unfortunately, no biogas refinery has been built in the Republic of Croatia, and according to available information, it is not in the plans.

## CONCLUSIONS

Our considerations - on the example of the Republic of Croatia - showed:

- That BgP have the most favorable effects on the GDP of the national economy - compared to other renewable sources - through investment, intermediate consumption and employment of domestic labor and activation of national resources.
- Importat benefits for the national economy are to: reducing CO<sub>2</sub> emissions and municipal waste disposing; fewer imports of electricity, gas, and oil; significantly better economic performance in energy; balancing functioning of the national electricity system; hiring domestic companies and activating domestic resources; and Use of biogas in transport
- European developed countries are achieving strong growth in biogas capacity building and biogas use, and especially strong growth in biogas refining capacity (biomethane production).
- States in the Pannonian area should pay special attention to investments in renewable energy sources and objectify the eco-friendly, ecological and energy effects of certain forms of renewable energy sources, and not be subject to the influence of interest lobbies without a critical approach.

## REFERENCES

- [1] Glavaš, H.; Ivanović, M.; Mandić, N.: Resources and Possibilities of Agro Biomass Usage for Energy Purposes in Slavonia region (Croatia), ENERGYCON 2014; IEEE, Dubrovnik, Croatia 13-16 May, 2014; Proceedings pp 4.1 – 6

- [2] Ivanović, M.; Glavaš, H.; Vukobratović, M: - Bioplinne elektrane u Slavoniji i Baranji, 15. skup o prirodnom plinu, toplini i vodi, Osijek, 27.-29.09.2017. Proceedings, pp 204-215
- [3] Ivanović, Milan - Komunalno zbrinjavanje otpada – stanje u gradovima slavonske regije; 28<sup>th</sup> International Conference OTO 2019. Vinkovci, Decembre 12, 2019; Panon think tank Osijek, Proceedings, pp 163-172
- [4] Ivanović, Milan - Kružna ekonomija i bioplinne elektrane u Slavoniji i Baranji; 35. Međunarodni znanstveno-stručni susret stručnjaka za plin, October 21 – 23, 2020,. Proceedings, pp 225-235
- [5] Ivanović, Milan - Bioplin u kružnoj ekonomiji Europske Unije; 35. Međunarodni znanstveno-stručni susret stručnjaka za plin, October 21 – 23, 2020, Proceedings, pp 236-247  
<https://www.researchgate.net/publication/344905290>
- [6] EI „Hrvoje Požar“ & Ekonomski institut Zagreb. Integralna analiza dosadašnjih učinaka razvoja i izgradnje obnovljivih izvora energije u Hrvatskoj u razdoblju od 2007. do 2016. Zagreb, 2018.  
[https://www.hops.hr/page-file/CwqtWjjSgKIf9Qfz07pFB5/ostale-publikacije/Analiza\\_OIE\\_Final.pdf](https://www.hops.hr/page-file/CwqtWjjSgKIf9Qfz07pFB5/ostale-publikacije/Analiza_OIE_Final.pdf)
- [7] HROTE – (<http://www.hrote.hr/>)  
(access. 7/27/2021)
- [8] CONSULTARE d.o.o. Vrbovec - <https://www.consultare.hr/hr/projekti/bpp-slatina#>  
(access. 7/27/2021)
- [9] Ivanović, Milan; Tonković, Zlatko: Kapaciteti za rafinaciju bioplina i korištenje biometana u EU, PLIN 2021 - 19. skup o prirodnom plinu, toplini i vodi, Osijek, September, 22 – 23, 2021, Proceedings, pp 216-227
- [10] Policy Brief: Bioelectricity, Bioenergy Europe Statistical Report 2020  
<https://bioenergyeurope.org/article.html/241>  
(access. 7/27/2020)

## THE IMPACT OF VALID REGULATIONS ON ELECTROMAGNETIC FIELDS OF THE ERNESTINOVO SUBSTATION

Robert Noskov<sup>1</sup>, Ivica Petrović<sup>1,2</sup>, Hrvoje Glavaš<sup>2</sup>

<sup>1</sup>Croatian Transmission System Operator, Zagreb, Croatia

<sup>2</sup>University of Osijek, Faculty of Electrical Engineering,  
Computer Science and Information Technology, Osijek, Croatia

e-mail: [robert.noskov@hops.hr](mailto:robert.noskov@hops.hr)

**Abstract:** Expanding industrialization and energy consumption lead to further energy grid development, which inherently, leads to extensive exposure to electromagnetic fields. Electromagnetic radiation that is produced by man artificially and does not come directly by natural means can be consider as electromagnetic pollution. Electromagnetic pollution, unlike other contaminants caused by human negligence, is invisible to the naked eye, and therefore, its influence was neglected for a long time. Electromagnetic radiation of extremely low frequencies (ELF) is produced by electric equipment and other grid parts which conduct electricity. This electromagnetic field (EMF) is non-ionizing and, therefore, its environmental impact is not immediate but rather manifested after long exposure. This paper presents a brief overview of extremely low frequency radiation impact on living organisms as well as a visualization of (ELF) data from case study of EMFs of the Croatian transmission grid.

**Key words:** EMF, environmental impact, transmission grid.

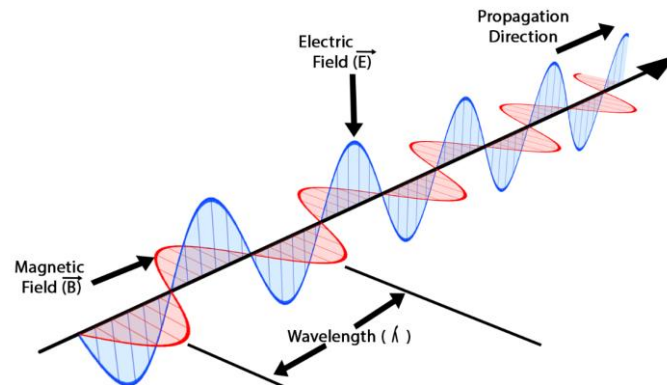
### INTRODUCTION

Every living organism is a bioelectric system which functions as a result of internal bio-chemical processes as well as various environmental influences. The mechanisms of the interaction between electromagnetic fields and the living world, as well as the physical body, are still not fully understood. Exposure to and effects of external electromagnetic fields can sometimes have positive, but in certain circumstances negative, effects on health and the living world. All research conducted so far, especially in recent years, confirms that electromagnetic fields are biologically active in human beings but also in the animal world. In the last few decades, the entire living world has been exposed to increasing levels of electromagnetic fields originating from various electrical devices, power plants as well as home installations. The growing need for electrical power in the industrialized world has pushed the level of electromagnetic contamination even further. These levels are more expressed in urban areas but, in recent years, more and more rural areas also experience this issue.

The current regulations on are based on the 2010 Guidelines for limiting exposure to time-varying electric and magnetic fields (1 Hz to 100 kHz) from International Commission on Non-Ionizing Radiation Protection (ICNIRP) [1], which succeeded the 1998 version and is supported by the latest report of the Scientific Committee on Growing and Newly Identified Health Risks (SCENIHR). In such circumstances, the scientific community together with standardization organizations and regulatory bodies prescribes appropriate standards as well as methods of protection against possible harmful health effects of the EMFs on human beings. In Croatia, laws and accompanying policies have been adopted that regulate this matter in accordance with the applicable EU directives. The Croatian Ministry of Health is responsible for implementing measures for protection against non-ionizing radiation in accordance with the Non-Ionizing Radiation Protection Act (Official Gazette 91/10) and the Ordinance on Electromagnetic Field Protection (Official Gazette 146/14 and 31/19), [2]. More and more scientific research confirms the occurrence of harmful health effects on people exposed to EMFs at significantly lower levels than those prescribed in current legal and standardization documents [4]. This requires a concerted effort by all stakeholders to adopt a new regulatory and standardization framework that will better ensure the protection of human health while the widespread use of wireless technologies, and overall increase in power consumption, continues to grow.

## ELECTROMAGNETIC FIELD RADIATION

The EMF radiation generally refers to the spread of energy through space. Electromagnetic energy spreads through space in the form of an electromagnetic wave, which represents the partial propagation of interdependent electric and magnetic fields waves. Fig. 1 shows the EM wave propagation through space [4].



**Fig. 1.** EM wave propagation

One of the basic variables of the EM is frequency and represents the rate of change in the wave amplitude. The following relation connects frequency ( $f$ ) and wavelength ( $\lambda$ ):

$$c = \lambda \cdot f \quad (1)$$

where  $c$  represents the speed of light (roughly  $3 \times 10^8$  m/s).

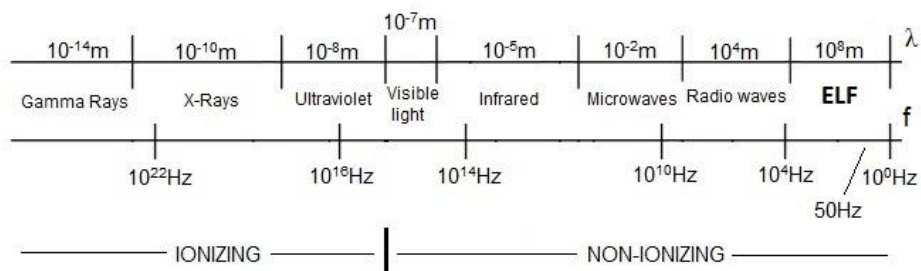
Due to its dual nature, the EM wave can also be represented by energy carrying particles called photons. The energy of each individual photon can be expressed by:

$$E_f = h \cdot f \quad (2)$$

where  $h$  refers to the Planck constant ( $h=6.62 \times 10^{-34}$  Js).

Due to these relations, it can be concluded that at high frequencies the energies of the photons are so significant that, when colliding with other matter, they can break the chemical bonds between particles and therefore ionize the substance. This radiation is referred to as ionizing and it is long accepted to be dangerous to human health and the environment.

The radiation of lower frequencies (non-ionization radiation) does not have any immediate consequences to the human body and was, therefore, neglected for a long period of time. Radiation in this specter include microwaves, radio waves, infrared and the visible light as well as the electric power grid (50/60 Hz). Fig. 2 shows the EM specter of ionizing and non-ionizing radiation [3].



**Fig. 2.** EM specter of ionizing and non-ionizing radiation, source [3]

The influence of the interaction of time-varying electric fields with the human body leads to the flow of electric current charges, charge polarization (formation of electric dipoles) and re-routing of already existing electric dipoles in tissues [1]. As far as magnetic fields are concerned, the result of the interaction with the human body is the formation of an induced electric field and a circular electric current. The strength of the induced fields and the current density are proportional to the radius of the circular currents, the electrical conductivity of the tissue, the rate of change, and the magnitude of the magnetic flux density. Exposure to electromagnetic fields at frequencies higher than 100 kHz leads to significant energy absorption and a significant increase in temperature.

### **Extremely low frequency EMFs**

The focus of this paper is the measurement and influence of the extremely low frequency (ELF) EMFs on human health and the environment as these frequency specters occur in the power grid. As the ELF radiation is non-ionizing there is no immediate danger to the human body but the impact with long exposures has been studied. The source of the ELF radiation is a transformer substation, a power line, an electric power plant and any other electric equipment with a nominal voltage above 1 kV.

Substantial evidence indicates that ELF is carcinogenic at levels of exposure in the 2mG to 5 mG (0.2-0.5  $\mu$ T) range and above. ICNIRP and other standards that place public exposure limits as high as 1,000 mG (100  $\mu$ T) are outdated and should be replaced [3].

One of the major concerns of exposition to such fields can be the development of leukemia in children. A neural and muscle dysfunction is also possible, because the interaction of a stronger field causes unwanted stimulation in the central nervous system, although there are conflicting evidence in experimental studies. As [5] states, "Resolving the conflict between epidemiological data (which show an association between ELF magnetic field exposure and an increased risk of childhood leukemia) and experimental and mechanistic data (which do not support this association) is the highest research priority in this field."

Other sources state that exposure to ELF fields can also be responsible for increased anxiety and stress levels, sleep disorders, changes in calcium homeostasis as well as other protein levels in the body etc.

### **The EMF radiation regulative**

In 1999, the Council of Europe adopted an act (1999/519/EC) that that introduces limiting values for exposure of the general population to electromagnetic fields in the frequency range 0 Hz up to 300 GHz (Table 2). The limit values given in this act are in comply with ICNIRP guidelines from 1998 (later revised in 2010). Each country prescribes its limit values for electromagnetic emissions, so individual countries generally have stricter criteria and thresholds than those given in ICNIRP recommendations.

**Table 1.** Council of Europe recommended thresholds for the EMF exposure of general population

<b>Frequency f (Hz)</b>	<b>Electric field E (V/m)</b>	<b>Magnetic field H (A/m)</b>	<b>Magnetic field density B (<math>\mu</math>T)</b>	<b>Power density S<sub>ekv</sub> (W/m<sup>2</sup>)</b>
<1	-	32000	40000	-
1-8	10000	32000/f <sup>2</sup>	40000/f <sup>2</sup>	-
8-25	10000	4000/f	5000/f	-
250-8000	250/f	4/f	5/f	-
8000-3000	250/f	5	6,25	-
3-150 k	87	5	6,25	-
0,15-1 M	87	0,73/f	0,92/f	-
1-10 M	87/f <sup>1/2</sup>	0,73/f	0,92/f	-
10-400 M	28	0,073	0,092	2
400-2000 M	1,375 f <sup>1/2</sup>	0,0037 f <sup>1/2</sup>	0,0046 f <sup>1/2</sup>	f/200
2-300 G	61	0,16	0,20	10

In Croatia, the Non-Ionizing Radiation Protection Act was passed in 1999 (latest edition in 2019), which determines the principles for the protection of people from non-ionizing emissions. This act defines the area of increased sensitivity and the area of professional exposure [2].

Areas of enhanced sensitivity are areas of residential zones where people may be present 24 hours a day; schools, pre-school education institutions, maternity hospitals, tourist accommodation facilities, and children's playgrounds; areas of undeveloped plots; where vulnerable groups of the population may be present.

Areas of professional exposure are areas where work is conducted and that are not in the area increased sensitivity. In these areas individuals can remain for up to 8 hours a day, as their exposure to electromagnetic fields is controlled. In Croatia, the current limit levels of the EM field for overhead lines are shown in Table 2.

**Table 2.** Croatian threshold values of electric field and flux density in the vicinity of overhead lines

Type of power line	Electric field E (V/m)	Magnetic field density B ( $\mu$ T)
Newly installed line / Area of professional exposure	5	100
Newly installed line / Areas of enhanced sensitivity	2	40
Existing line / Area of professional exposure	5	100
Existing line / Areas of enhanced sensitivity	5	100

It can be seen that there is an increase in the safety and, therefore, a decrease in threshold values for both the electric field and the magnetic flux density of newly installed overhead lines.

### EXPERIENCE IN THE CROATIAN TSO

The Croatian Transmission System Operator is the independent transmission operator in the country and manages power lines and substation with nominal voltage of 400, 220 and 110 kV. This paper will present the electromagnetic field values of the substation 400/110 kV Ernestinovo [6]. Figure 3 show the bird's-eye view of the Ernestinovo substation.



**Fig. 3.** Bird's-eye view of the TS 400/110 kV Ernestinovo, source [7]

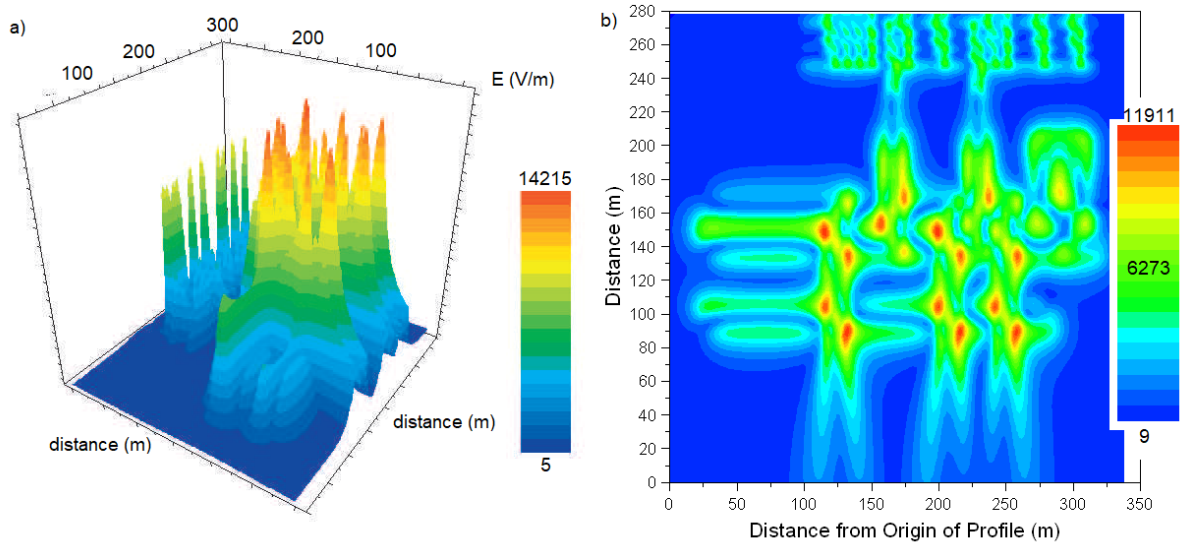
### Electromagnetic field measurement and calculation in TS 400/110 kV Ernestinovo

The primary source of ELF radiation in the substation 400/110 kV Ernestinovo are 5 overhead lines connected to the 400 kV side, 2 400/100 kV power transformers and a 10 overhead lines on the 110 kV side. According to the Law on Non-ionizing radiation protection, the permissible values of the electric field and magnetic field density are:

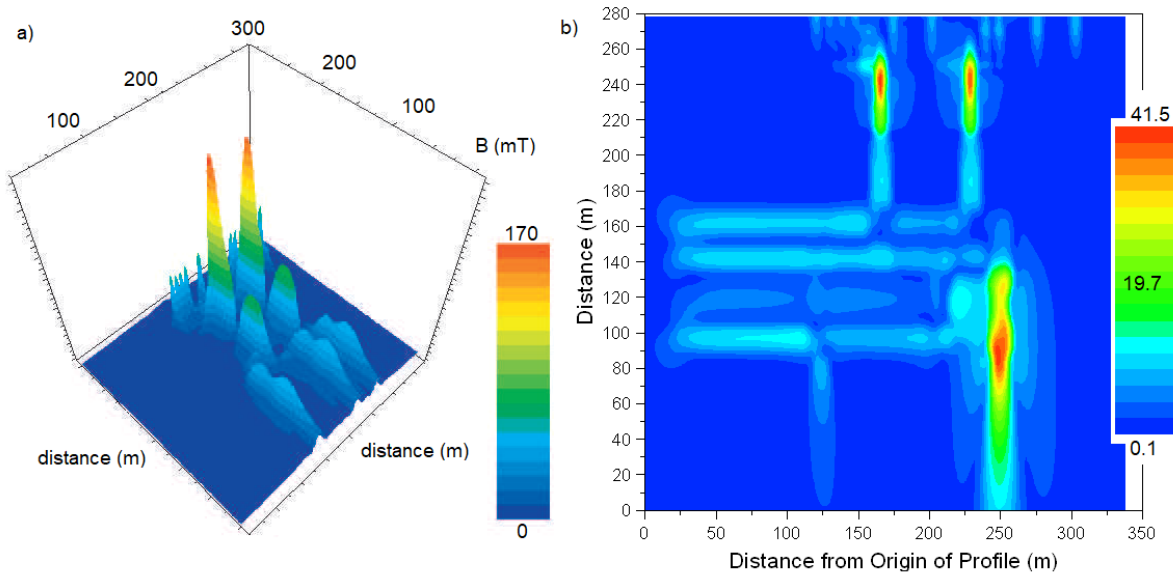


- for the field of professional exposure (8 hours per day):
  - electric field intensity  $E_{8h} = 5000 \text{ V/m}$ ;
  - magnetic field density  $B_{8h} = 100 \text{ }\mu\text{T}$ ,
- for the field of enhanced sensitivity (24 hours per day):
  - electric field intensity  $E_{24h} = 2000 \text{ V/m}$ ;
  - magnetic field density  $B_{24h} = 40 \text{ }\mu\text{T}$ .

According to [8], All calculations have been conducted in the space of 2 meters above ground. The greatest calculated electric field occurs directly under the 400 kV busbar system (14000 V/m). The calculated electric field around the fence (outside of the substation) is generally less than 1000 V/m except under the overhead line where the values go somewhat below 2000 V/m under the 110 kV lines and between 2000-4000 V/m under the 400 kV lines, which is greater than the permissible threshold for 24h stay. Figure 4 shows the computed values of the electric field, and Figure 5 shows the computed values of the magnetic field density.



**Fig. 4.** Electric field a) Spatial distribution [8] b) Computed values for E-field on the whole plane [9]



**Fig. 5.** Magnetic field a) Spatial distribution [8], b) Distribution on the plane [9]

The magnetic field computation cannot be accurately made due to the impossibility to predict the current flow through the conductors at any given moment [8]. Measurement concludes that there are

significantly less violations of the threshold values than with the electric field. The value of 100  $\mu\text{T}$  (for operating personnel) is exceeded only under the conductors connecting the power transformers and the 400 kV and 110 kV busbars [9]. This is not shown with the computed method, but this is expected due to the abovementioned limitation for the computation model.

## CONCLUSION

Exposure to high values of electromagnetic fields can have hazardous effects on human beings as well as the environment. Low frequency electromagnetic fields do not have immediate effects but studies have shown correlation between long term low frequency electromagnetic field exposure and several illnesses. Also, education plays a crucial role in self prevention as the general public lacks understanding on this matter. Analysis conducted in the TS 400/110 kV Ernestinovo detected several violations of electromagnetic field thresholds for 8-hour exposure of working personnel and, also, 24-hour exposure violations outside of the substation where general population might reside.

Therefore, there is an imperative to update the current regulative for existing and newly installed objects. This especially concerns objects in urban areas as there are permanent housing complexes in the near vicinity.

## REFERENCES

- [1] ICNIRP Guidelines For Limiting Exposure To Time-Varying Electric And Magnetic Fields (1Hz – 100 kHz), Published in: Health Physics 99(6), pp.818-836, 2010. DOI: [10.1097/HP.0b013e3181f06c86](https://doi.org/10.1097/HP.0b013e3181f06c86)
- [2] RH, Law On Non-Ionizing Radiation Protection, Official Gazette of the Republic of Croatia 91/10, 114/180 [https://narodne-novine.nn.hr/clanci/sluzbeni/2010\\_07\\_91\\_2571.html](https://narodne-novine.nn.hr/clanci/sluzbeni/2010_07_91_2571.html)
- [3] Carpenter, D., Sage, C.: Public health policy for electromagnetic field exposures, Reviews on Environmental Health, 23(2), pp.91-117, April, 2008.
- [4] Haznadar, Z., Štih, Ž.: Electromagnetism 1 i 2, Školska knjiga, Zagreb, 1997.
- [5] World Health Organization (WHO), Extremely low frequency fields. Environmental Health Criteria, Volume 238. Geneva: WHO, 20074.
- [6] Technical documentation of TS 400/110 kV Ernestinovo project Rade Končar-Engineering for energy and transport, d.d. Zagreb, 2003.
- [7] Koncar-KET, <https://demo.virtualvalley.net/pavilion/ICT/stand/koncar-ket/gallery> (accessed September 2021).
- [8] Nikolovski, S., Marić, P., Baus, Z.: Electromagnetic Field Calculation of Transformer Station 400/110kv Ernestinovo Using the CDEGS Software, Journal of Electrical Engineering, Vol. 58, No. 4, pp.207–213, 2007.
- [9] Nikolovski, S., Klaić, Z., Štefić, B.: Measurements and Computation of Electromagnetic Field in Transformer Station 400/110 kV Ernestinovo, IEEE Bucharest Power Tech Conference, Bucharest, Romania, June 28<sup>th</sup>-July 2<sup>nd</sup> 2009. doi:[10.1109/ptc.2009.5281994](https://doi.org/10.1109/ptc.2009.5281994)

## STATISTICAL EVALUATION OF SOME FIVE PARAMETERS SORPTION ISOTHERMS MODELS

Vangelce Mitrevski<sup>1</sup>, Cvetanka Mitrevska<sup>2</sup>

<sup>1</sup>University St.Kliment Ohridski, Faculty of Technical Sciences, Bitola, North Macedonia

<sup>2</sup>International Slavic University Gavrilo Romanovic Derzavin, Faculty for Safety  
Engineering, Sveti Nikole, North Macedonia

e-mail: [vangelce.mitrevski@uklo.edu.mk](mailto:vangelce.mitrevski@uklo.edu.mk)

**Abstract:** In the scientific literature various mathematical models are available for modelling on equilibrium moisture content data of food materials. The objective of the presented article was statistical evaluation of fifteen five parameters sorption isotherm models and to make comparison on their goodness of fit. The analysed sorption isotherm models were taken from the reference scientific literature and some of them were originally generated. The value on coefficient of determination and graphical evaluation of the residual randomness were the main assessment criterions for statistical evaluation of the sorption isotherm models. The statistical performances of those models were tested on the equilibrium moisture content data of quince. Based on the performed statistical analysis the model of Popovski & Mitrevski i.e. model with referent number M03 has the best statistical performances.

**Key words:** five parameters models, statistical evaluation, moisture content data.

### INTRODUCTION

In the scientific literature numerous mathematical models for approximation of sorption isotherm data of agricultural and food materials are used. Depending on the number of parameters included in the model for approximation of moisture sorption data, the models may be one, two, three, four or more parametric [7]. In the last two decades an increasing number of articles were reported in this area. These articles includes the methods for determination of sorption or desorption isotherms [4,6], temperature dependence of sorption isotherms [8], determination of heat of sorption [2] and development of mathematical models for approximation of moisture sorption data [3,5]. In engineering calculations, the simplicity of a mathematical model, i.e. a model with a smaller number of parameters is of great importance. In the case where the sorption isotherm model is incorporated into the mathematical model for calculating the drying processes or used to predict the shelf-life of the packaged dried product, then the approximation of the experimental data on equilibrium moisture content has a greater significance in relation to the accuracy of the theory which is based on it [1]. The objectives of the presented article was statistical evaluation of fifteen five parameters sorption isotherm models for approximation of equilibrium moisture data of quince and to make comparison on their goodness of fit based on coefficient of determination and graphical evaluation of the residual randomness.

### MATERIAL AND METHODS

The equilibrium moisture content of quince was determined at temperatures of 15, 30, 45 and 60°C using static gravimetric method [6,7]. Ten saturated salt solutions  $\text{LiCl}$ ,  $\text{CH}_3\text{COOK}$ ,  $\text{MgCl}$ ,  $\text{K}_2\text{CO}_3$ ,  $\text{Mg}(\text{NO}_3)_2$ ,  $\text{NaBr}$ ,  $\text{SrCl}_2$ ,  $\text{NaCl}$ ,  $\text{KCl}$  and  $\text{BaCl}_2$  were used to give defined constant equilibrium relative humidity in the glass jars from 0.110 to 0.920. Two dry samples of quince were placed on holder into each of the ten glass jars and exposed to atmospheres of various relative humidity. The glass sorption jars were placed and kept in the temperature controlled cabinet type SANYO MCO-15AC (SANYO Electric Co., Ltd. Refrigeration Products Division 1-1-1, Sakata Oizumi-Machi, Ora-Gun, Gunma 370-0596 Japan), maintained at temperatures 15, 30, 45 and 60°C with an accuracy of  $\pm 0.1^\circ\text{C}$ . Three replications were made at each temperature and equilibrium relative humidity in the glass jars, using two samples per replication and the average values of equilibrium moisture content were calculated [6,7]. The change of samples mass was determined by electrical balance type KERN PLJ360-3M (Kern&Sohn GmbH, Ziegelei 1, 72336 Balingen, Germany), with precision of 0.001 g every 7 days.

The equilibrium between samples and their environment was reached after 21 days when is achieved by the constant weight after two successive weighing of samples. The equilibrium moisture content of the quince samples was determined gravimetrically by drying in an oven at temperature of 105°C and atmospheric pressure for 24 h.

## RESULTS AND DISCUSSIONS

The experimental values for the equilibrium moisture content,  $X_{eq}$  on the quince slices at each water activity,  $a_w$  for the four different temperatures were fitted with fifteen five-parameters sorption isotherm models M01-M15, tab.1.

**Table 1.** Mathematical model for approximation sorption data of quince

Number of model	Name of model	Model	References
M01	D'Arcy-Watt	$X_{eq} = \frac{ABa_w}{1 + Aa_w} + Ea_w + \frac{CDa_w}{1 - Ca_w}$	[10]
M02	Popovski-Mitrevski	$X_{eq} = \left( \frac{A}{1 - Ba_w} + \frac{Ca_w}{1 - Da_w} \right) a_w + E$	[9]
M03	Popovski-Mitrevski	$X_{eq} = \left( \frac{A}{1 - Ba_w} + \frac{Ca_w}{1 - Da_w} \right) \frac{a_w}{1 - a_w} + E$	[9]
M04	Popovski-Mitrevski	$X_{eq} = Aa_w^B + Ca_w^D + E$	[9]
M05	Popovski-Mitrevski	$X_{eq} = Ae^{Ba_w} + Ce^{Da_w} + E$	[9]
M06	Popovski-Mitrevski	$X_{eq} = A \left( \frac{a_w}{1 - a_w} \right)^B + C \left( \frac{a_w}{1 - a_w} \right)^D + E$	[9]
M07	Popovski-Mitrevski	$X_{eq} = Ae^{B \ln^2 a_w} + Ce^{D \ln^2 a_w} + E$	[9]
M08	Popovski-Mitrevski	$X_{eq} = \frac{A}{1 - Ba_w} + \frac{C}{1 - Da_w} + E$	[9]
M09	Popovski-Mitrevski	$X_{eq} = A(-\ln a_w)^B + C(-\ln a_w)^D + E$	[9]
M10	Popovski-Mitrevski	$X_{eq} = \left( \frac{A}{1 - Ba_w} + \frac{C}{1 - Da_w} \right) (1 + a_w) a_w + E$	[9]
M11	Popovski-Mitrevski	$X_{eq} = A[-\ln(1 - a_w)]^B + C[-\ln(1 - a_w)]^D + E$	[9]
M12	Popovski-Mitrevski	$X_{eq} = \frac{A}{B - \ln a_w} + \frac{C}{D - \ln a_w} + E$	[9]
M13	Popovski-Mitrevski	$X_{eq} = A(1 - a_w)^B + C(1 - a_w)^D + E$	[9]
M14	Popovski-Mitrevski	$X_{eq} = \left[ \frac{A}{(1 - Ba_w)^2} + \frac{C}{(1 - Da_w)^2} \right] a_w + E$	[9]
M15	Popovski-Mitrevski	$X_{eq} = \frac{Aa_w}{1 - Ba_w} + \frac{Ca_w^D}{1 - a_w} + E$	[9]

The procedure for statistical evaluation of sorption isotherm model depends on the nature of the model. In scientific literature, for the goodness of fit of experimental sorption data and selection of the best isotherm model, following statistical criteria are used: coefficient of determination,  $R^2$ , root mean squared error, RMSE, and the mean relative deviation, MRD. The selection of a sorption isotherm model with graphical evaluation of the residual randomness is also popular [3]. Plotting of the residuals against independent variable is a measure of distribution errors. If the sorption model is correct, then the residual should be only random independent errors with a zero mean, constant variance and arranged in a normal distribution. If the residual plots indicate a clear pattern, the model

should not be accepted [3]. In this study the value on coefficient of determination,  $R^2$  and graphical evaluation of the residual randomness were the main statistical indicators for selection of the best five parameters sorption isotherm model.

Because the regression methods (indirect nonlinear or direct nonlinear), estimation method, the initial step size, the start values of parameters, convergence criterion and form of the function have significant influence on accuracy of estimated parameters, a large number of numerical experiments were performed [4]. The method of indirect non-linear regression analysis and estimation methods of Quasi-Newton, Simplex, Simplex and quasi-Newton, Hooke-Jeeves pattern moves, Hooke-Jeeves pattern moves and quasi-Newton, Rosenbrock pattern search, Rosenbrock pattern search and quasi-Newton, Gauss-Newton and Levenberg-Marquardt from computer software Statistica (Statsoft Inc., Tulsa, OK, <http://www.statsoft.com>), were used to approximate the experimental equilibrium moisture content data of quince. On the basis of experimental data, and each mathematical model from tab. 1, the values of coefficient of determination,  $R^2$ , was calculated. After that, the models were ranked on the basis of values of the coefficient of determination (tab.2).

**Table 2.** Ranking of the models

Model	$R^2$	Rank	Model	$R^2$	Rank
M01	0.9913	3	M09	0.9901	7
M02	0.9913	3	M10	0.9913	3
<b>M03</b>	<b>0.9916</b>	<b>1</b>	M11	0.9911	4
M04	0.9915	2	M12	0.9913	3
M05	0.9915	2	M13	0.9910	5
M06	0.9907	6	M14	0.9913	3
M07	0.9910	5	M15	0.9913	3
M08	0.9911	4	-	-	-

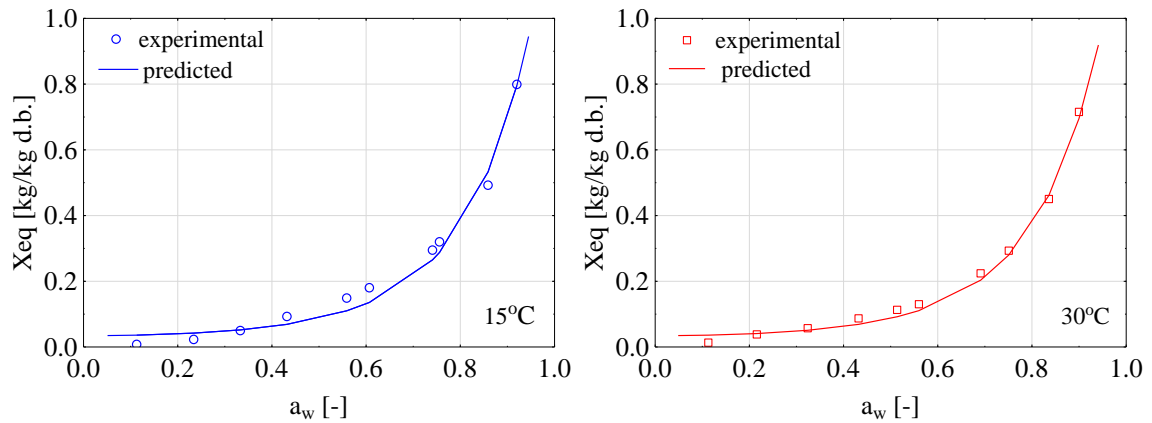
From tab. 2 it is evident that the model of Popovski&Mitrevski with referent number M03, has the highest value of coefficient of determination,  $R^2 = 0.9916$  (rank 1). So, this model correlates the experimental values of sorption data of quince better than other models. Similar, highest value of coefficient of determination was obtained when two-parameters sorption isotherm models were used for approximation of sorption data of quince [7]. From all models, the model with referent number M09, has the smallest value of coefficient of determination,  $R^2 = 0.9901$  (rank 7). So, this model exhibited the worst statistical performance when is used to correlate the experimental values of equilibrium moisture content data of quince. The values of model parameters, A, B, C, D, E for the model M03, were estimated by fitting the models to experimental equilibrium moisture content data of quince using estimation methods which minimizes the sum squares errors. The estimated values of parameters are given in tab.3.

**Table 3.** Estimated values of parameters for model M03

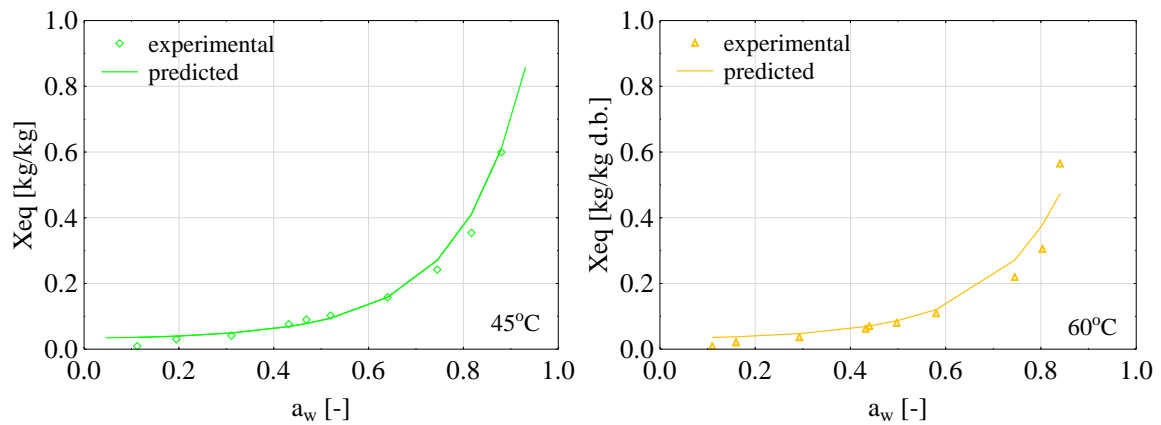
Model	A	B	C	D	E
$XEQ = ((A/(1-B*AW))+(C/(1-D*AW)))$ $*(AW/(1-AW))+E$	0.1372	-	-	1.0601	-
		0.5734	0.0005		0.0052

XEQ - equilibrium moisture content, AW- water activity, A, B, C, D, E - parameters

The experimental and predicted values for equilibrium moisture content for quince at four temperatures are shown on Fig. 1a to Fig 1b.

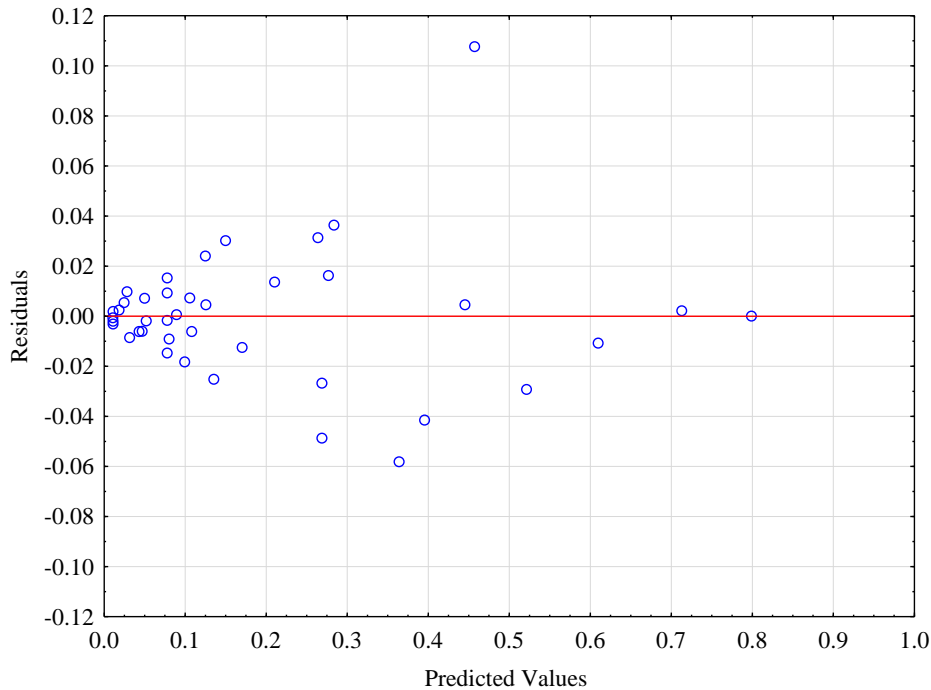


**Fig. 1a.** Experimental and predicted sorption isotherms for quince at 15 and 30°C - Model M03



**Fig. 1b.** Experimental and predicted sorption isotherms for quince at 45 and 60°C - Model M03

From fig.1a to fig1.b is evident that has a good agreement between the experimental and predicted values of equilibrium moisture data of quince. Analyzing the residues on regression analysis for the model M03, the plots of the residues against the predicted values did not indicate abnormal distribution. In fig.2 the plots of the residuals of non-linear estimation against the predicted values are presented.



**Fig. 2.** Residuals plot of sorption data versus predicted values for quince -Model M03

## CONCLUSION

In this study statistical performance on fifteen five parameters sorption models were studied. The statistical performances of those models were tested on the equilibrium moisture content data of quince. The value on coefficient of determination and graphical evaluation of the residual randomness were the main assessment criterions for statistical evaluation of the sorption isotherm models. In accordance with these statistical criterions it was concluded that the models of Popovski&Mitrevski i.e. model with referent number M03 has a better statistical fit on experimental equilibrium moisture data of quince in whole range of water activity than other five parameters models.

## REFERENCES

- [1] Boquet, R., Chirife, J., Iglesias, H., Equations for fitting water sorption isotherm of foods. II. Evaluation on various two-parameters model, *International Journal of Food Science and Technology*, 13(4), pp. 319-327, 1978.
- [2] Kaymak-Ertekin, F., Gedik, A., Sorption isotherms and isosteric heat of sorption for grapes, apricots, apples and potatoes, *LWT-Food Science and Technology*, 37(4), pp. 429-428, 2004.
- [3] Mitrevski, V., Mijakovski, V., Geramitcioski, T., Lutovska, M., Comparison between the transcendental and cyclometric sorption isotherm models, *Journal on Processing and Energy in Agriculture*, 16(1), pp. 1-5, 2012.
- [4] Mitrevski, V., Lutovska, M., Mijakovski, V., Pavkov, I., Babic, M., Radojcin, M., Adsorption isotherm of pear at several temperatures, *Thermal Sciences*, 19(3), pp. 1119-1129, 2015.
- [5] Mitrevski, V., Lutovska, M., Pavkov, I., Mijakovski, V., Popovski, F., The Power Series as Water Sorption Isotherm Models, *Journal of Food Process Engineering*, 39(2), pp. 178-185, 2015.
- [6] Mitrevski, V., Mitrevska, C., Mijakovski, V., Pavkov, I., Geramitcioski, T., Mathematical modelling of the sorption isotherms of quince, *Thermal Sciences*, 21(5), pp. 1965- 1973, 2018.
- [7] Mitrevski, V., Mitrevska, C., Geramitcioski, T., Babic, M., Popovski, K., Statistical evaluation of some two parameters sorption isotherms models, *Journal on Processing and Energy in Agriculture*, 23(1), pp. 1-5, 2019.

- [8] Popovski, D., Mitrevski, V., Temperature influence on desorption isotherms, Proceedings of the 14<sup>th</sup> International Drying Symposium (IDS 2004), Sao Paulo, 22-25 August, Vol. A, pp. 254-257, 2004.
- [9] Popovski, D., Mitrevski, V., Method of free parameter for extension of the water sorption isotherm models, 32<sup>nd</sup> International Conference of SSCHE May 23–27, Tatranske Matliare, Slovakia, Po-We-4, 146p.pdf., 2005.
- [10] Saravacos, D.G., Tsiourvas, D.A., Tsami, E., Effect of temperature on the water sorption isotherms of sultana raisins, Food Science, 51(2), pp. 381-383, 1986.
- [11] \*\*\*, Statistica (Data Analysis Software System), v.10.0, StatSoft, Inc, USA, 2011.



## HEAT STORAGE FOR RESIDENTIAL SECTOR APPLIANCE

Milena Mančić<sup>1</sup>, Miomir Raos<sup>1</sup>, Milena Medenica<sup>1</sup>, Milan Protić<sup>1</sup>

<sup>1</sup>University of Niš, Faculty of Occupational Safety in Niš

e-mail: [milena.mancic@znrfaq.ni.ac.rs](mailto:milena.mancic@znrfaq.ni.ac.rs)

**Abstract:** Over the last three decades, the electricity consumption of the residential sector in the European Union (EU-27) showed a significant increment. In 2019, households, or the residential sector, represented 26.3 % of final energy consumption or 16.9 % of gross inland energy consumption in the EU [2]. During the 10-year period from 2009 to 2019, the consumption of electricity by households in the EU rose by 0.8 %. Heating systems/electric boilers represent the highest share, about 19.1%, of the residential electricity consumption at European level. The combined use of solar energy for heating and cooling has the potential to upgrade solar thermal energy from mainly DHW provider to a major building energy supplier, with hot water storage buffer.

**Key words:** heat storage, solar thermal, household energy balance

### INTRODUCTION

Over the last three decades, the electricity consumption of the residential sector in the European Union (EU-27) showed a great increment from 1990 till 2005 [1], and from 2005 till 2019 it is in stagnation or increase is minor, but the residential sector is still the second biggest in electricity consumption, right after industry. Households use energy for various purposes: space and water heating, space cooling, cooking, lighting and electrical appliances and other end-uses (mainly covering uses of energy by households outside the dwellings themselves). Data on the energy consumption of households broken down by end-use, have been collected and published by Eurostat since 2017. In 2019, households, or the residential sector, represented 26.3 % of final energy consumption or 16.9 % of gross inland energy consumption in the EU [2]. During the 10-year period from 2009 to 2019, the consumption of electricity by households in the EU rise by 0.8 %. These figures on overall household electricity consumption are likely to be influenced, in part, by the average number of persons living in each household and by the total number of households, both of which are linked to demographic events. Other influences include the extent of ownership and use of electrical household appliances and consumer goods as well as the use of energy saving devices [2]. Furthermore, energy consumption for heating and cooling of a household is strongly affected by the level of energy efficiency measures implemented in the particular household (thermal insulation, quality of glazing, applied heating and cooling energy transformation technologies etc.), whereas the electricity consumption is also affected by the energy efficiency rating of the household appliances.

Residential sector is the second most important final energy „consumer“ with almost 30% of the total electricity consumption. This is the main reason why the efficient use of energy by domestic appliances, along with the possibility of recovering and reusing their waste heat, is becoming more and more relevant.

### Energy consumption in households in Europe and in Serbia

The energy consumption of households in the EU decreased between 2005 and 2016 [8,9]. During the last 15 years, energy efficiency improvements in space heating and the use of more efficient electrical appliances, as well as behavioral changes driven by higher energy prices and the 2008 economic downturn all contributed to reductions in overall energy consumption in the household sector. Increases in the number of appliances, average size of dwellings and number of dwellings partially offset these improvements [8].

Household energy consumption increased both in 2015 (by 4 %) and in 2016 (by 3 %) compared with 2014 and 2015 respectively. The relatively colder winters in these two years contributed to these increases. However, lifestyle changes such as more dwellings, more appliances per dwelling, changes in heating behavior (e.g. higher indoor temperatures) also contributed. Energy efficiency improvements were not significant enough to counteract these effects. In fact, since 2013 a slowdown

in the rate of the annual energy efficiency improvement has been observed year-on-year compared with the average annual rate of the 2005-2016 period. [8-11]

Energy use in the household sector differs widely between countries because of weather conditions, the state and age of the building stock and household appliances, the average size of the dwellings, the heating/cooling systems used, behavior (particularly with respect to cooking) and the level of implementation of energy efficiency measures. In 2016, per capita energy consumption in the household sector of the EU countries ranged from 0.2 tons of oil equivalent per capita (toe/capita) in Malta to 1 toe/capita in Finland. [2, 8-11]

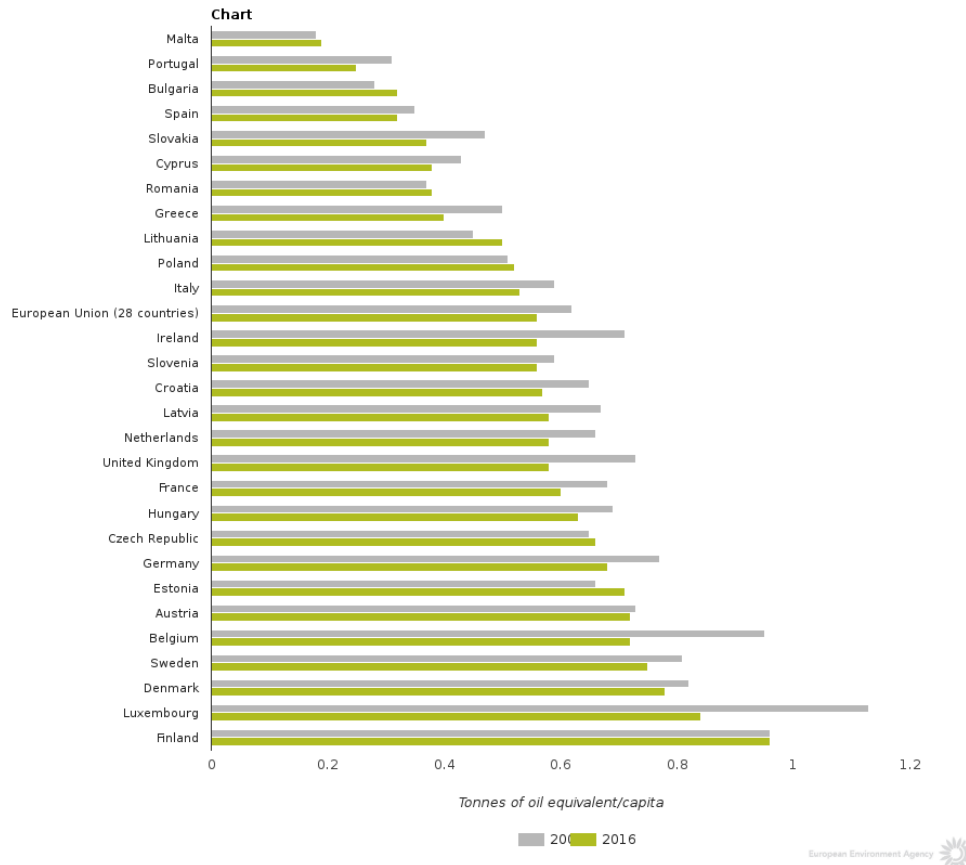


Fig. 1. Per capita final energy consumption of the households sector, by country [16]

As you can in Fig. 1. [8-11], biggest consumer in Europe, from all 27 countries is Finland and right next to Finland are Luxembourg, Denmark, Sweden, and explanation we can find in climate and temperature in the winter time in those countries. Finland in 2020, consumed the amount of electricity of 67,46 TWh, and just for comparison Serbia consumed 35.52 TWh in 2020. Like total energy consumption, the amount of electricity a country consumes in total is largely reflected by population size, as well as the average incomes of people in the given country.

There is a tendency of increased energy consumption in Serbia, while total dependency on imported energy, mostly petroleum and its products, is around 40% [4]. Housing industry's share in energy consumption amounts to 48% of total consumption, 65% of which refers to energy consumption in residential buildings ranging from 150 to 250 kWh/m<sup>2</sup> on average [3].

### Common appliances in households and their consumption

According to literature the number of domestic appliances in the European Union is continuously growing and the same goes for how often that appliance is in use, as well as for the duration of their duty cycles. That is the reason why despite the continuous development of high-efficiency appliances, it is expected that the electricity consumption in residential sector continuously increase. Heating systems/electric boilers represent the highest share, about 19.1%, of the residential electricity

consumption at European level [1]. While second, third and fourth place is reserved for refrigerators and freezers with energy consumption of almost 14.5%, then electric ovens, washing machines/dryers and dishwashers contribute on electricity consumption for 6.6%, 7.2% and 3% respectively [12]. The European Union is required to meet standards that imply eco-responsiveness and information for the design of efficient household appliances. Based on the higher performances of the new appliances, in July 2011 new labelling directives were adopted introducing new energy efficiency classes (A+++, A++ and A+) to the already available (A-G). On the basis of the most updated information at disposal [1, 12-14], in terms of performance and diffusion of household appliances, an assessment of the waste heat produced was carried out with the aim of evaluating the amount of thermal energy which should potentially be recovered and reused. At European level, the most common household appliances, are given through the Table 1.

**Table 1.** Energy consumption analysis for appliances that are biggest consumers

Appliance	Average energy consumption	Temperature
	[kWh/cycle]	[°C]
Refrigerators and freezers	640Wh/24h	35-50
Electric ovens	1.25	35-250
Dishwashers	0.8-0.95	40
Washing machines	1	30-35

According to model, given in the literature, parameters of active and stand-by consumption of an appliance are linked to the annual consumption model according to the following equation [3,6]:

$$E_{yearly} = \left( 3600 \times 24 \frac{s}{day} \dot{E}_{stand-by} + f \sum_{n=1}^{n_{cycle}} \dot{E}_{cycle,n} t_{cycle} \right) \frac{365}{3,6 \times 10^6} \frac{daykWh}{Ws} \quad (1)$$

where  $E_{yearly}$  is the mean consumption (kWh),  $E_{stand-by}$  is the electric load of an appliance in stand-by,  $E_{cycle,n}$  is electric load during a mean consumption cycle (W),  $t_{cycle}$  is time step n duration of a mean consumption cycle (s), and  $n_{cycle}$  is number of time steps of the mean consumption cycle. The difference in behaviour profile-electrical load on typical working day and at weekend was considered negligible. Basic energy efficient rated appliances were included in by the model: Television, electrical stove, Compact Disc player, personal computer, refrigerator with freezer, microwave oven, washing machine, and dishwasher. Thermal gain from use of these appliances was included in thermal balance of the building. Trend of change in daily electricity consumption due to climate changes throughout the year was synchronized with data from 41 by multiplying the time step value of electrical load by a monthly weight factor of the corresponding time interval [3,6,7].

### What is the thermo storage and its function?

Heat storage, also known as thermal energy storage (TES), generally involves the temporary storage of high- or low-temperature thermal energy for later use [15]. Heat storage (HS) stores thermal energy for later use. TS systems are used in buildings and industrial heating/cooling applications, but in recent years it is very common that even residential sector increasingly use heat storage. TES systems reduce peak demand, energy consumption, CO<sub>2</sub> emissions, and costs. In literature TES are described as “an advanced energy technology that is attracting increasing interest for thermal applications such as space and water heating, cooling, and air conditioning.”

Examples of heat storage applications include storage of solar energy for overnight heating, of summer heat for winter use, of winter ice for space cooling in summer, and of heat or cool generated electrically during off-peak hours for use during subsequent peak demand hours. In this regard, a heat

storage system is in many instances an useful device for offsetting temporal mismatches between thermal energy availability and demand.

All heat storage systems have three functions:

1. Charge: a heat source is used to provide heat to the storage medium.
2. Storage: a medium is used to store the heat for later use. The storage medium may be located at the heat source, the discharge, or somewhere else.
3. Discharge: heat is extracted from the storage medium in a controlled fashion for use.

Additionally, all heat storage systems consist of three basic parts storage material and, if applicable, a container for the storage material, also a heat exchanger to facilitate heat transfer to and from the storage material and a control system that facilitates the charging and discharging of the thermal storage.

### What should we take into account when we try to optimal capacity

The combined use of solar energy for heating and cooling has the potential to upgrade solar thermal energy from mainly DHW provider to a major building energy supplier. The simulation of the system is done in Trnsys software, and scheme is given in Figure 2. A closed loop consisting of an evacuated tube solar collector and a variable speed pump provide the hot stream of a heat exchanger within a sealed tank filled with an energy storage medium such as non-potable water. Water is drawn from the mains through another heat exchanger within the same tank and preheated before delivery to the storage tank, where it is further heated by gas (if necessary) before use.

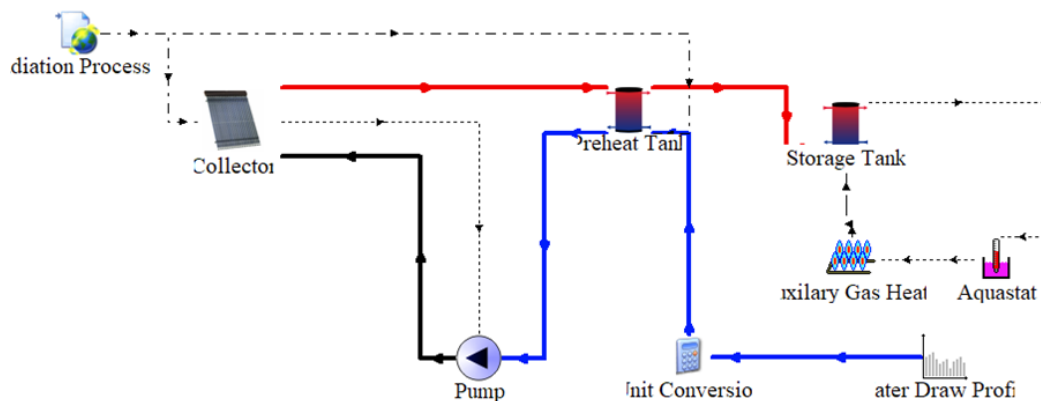


Fig. 2. Schematic representation of the considered system

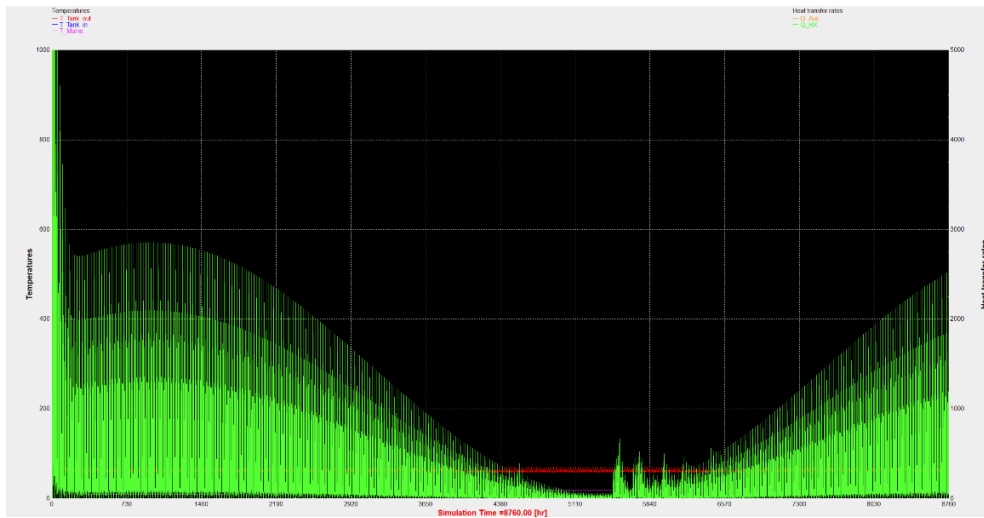
As it is given on Fig. 2, we have two solar collectors, and one Preheat storage tank and one Storage tank. The solar collectors are chosen to respond to demands so that the system does not enter the realm of stagnation, and it is the reason why we have reheater (also presented in the Figure 2). Components that we used in our simulation are:

1. Radiation Processor- provides solar radiation data, ambient temperature, and water mains temperature;
2. Collector -models evacuated tube solar collector; variable behavior;
3. Pump- Variable speed pump, controlled by collector behavior;
4. Preheat Tank- sealed tank with dual heat exchangers to provide preheating of mains water 0.5 m<sup>3</sup>;
5. Water Draw Profile - instant water draw profile used by SRCC;
6. Unit Conversion - converts from GPM to kg/hr;
7. Storage Tank- stores preheated water 1 m<sup>3</sup>;
8. Auxiliary heater - heats water in storage tank if necessary;

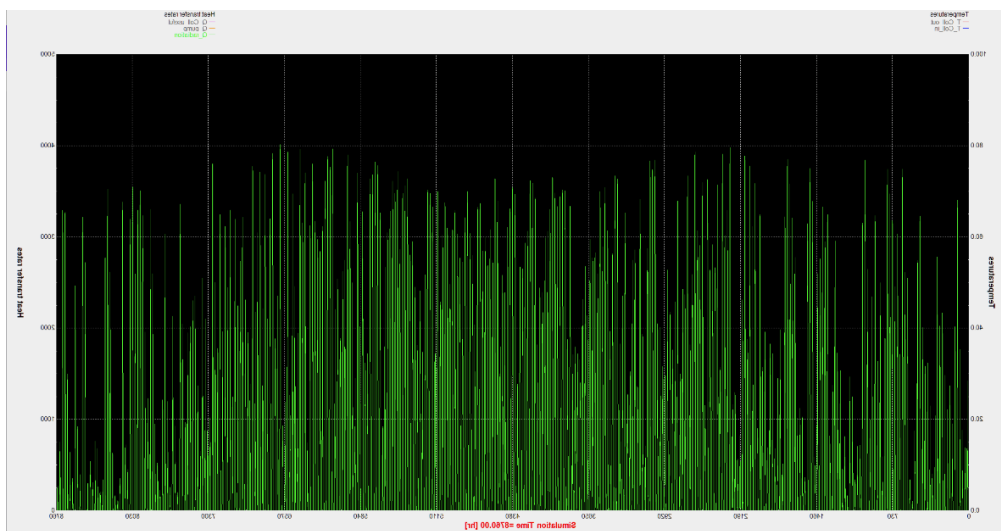
9. Aquastat -generates control signal for gas heater based on storage tank temperature.

## RESULTS AND DISCUSSION

The results obtained by simulation are presented in next few figures. The first of all, simulation is given for the whole year, 8760h. The heat exchanger fluid is water with: density  $1000[\text{kg}/\text{m}^3]$ , thermal conductivity  $2.14 [\text{kJ}/\text{hmK}]$ , specific heat  $4.19 [\text{kJ}/\text{kg K}]$ . Tank properties are: number of tank nodes is 8, tank volume is  $1[\text{m}^3]$ , top and bottom loss coefficient is  $5[\text{kJ}/\text{hm}^2\text{K}]$ , and initial tank node temperature is  $55[^\circ\text{C}]$ . Solar collector has a array area of  $2[\text{m}^2]$ , number of nodes is 10, flow rate per unit area is  $50[\text{kg}/\text{hm}^2]$ . Aquastat is set so that fluid inlet temp. is  $20[^\circ\text{C}]$ , and setpoint temperature for stage is  $50[^\circ\text{C}]$ . Hysteresis  $\pm 2 [^\circ\text{C}]$ . Preheater has heating capacity of  $16200[\text{kJ}/\text{h}]$ . The results in the paper are presented for a typical meteorological year, for the solar radiation data for Nis, Serbia, with 1h timestep resolution.



**Fig. 3.** Annual solar thermal system results (green – heat exchanger transferred energy in kJ/h, red – tank outlet temperature in  $^\circ\text{C}$ , blue Tank inlet temperature in  $^\circ\text{C}$ , purple – mains water temperature in  $^\circ\text{C}$ )



**Fig. 4.** The amount of the amount of solar radiation in kJ/h

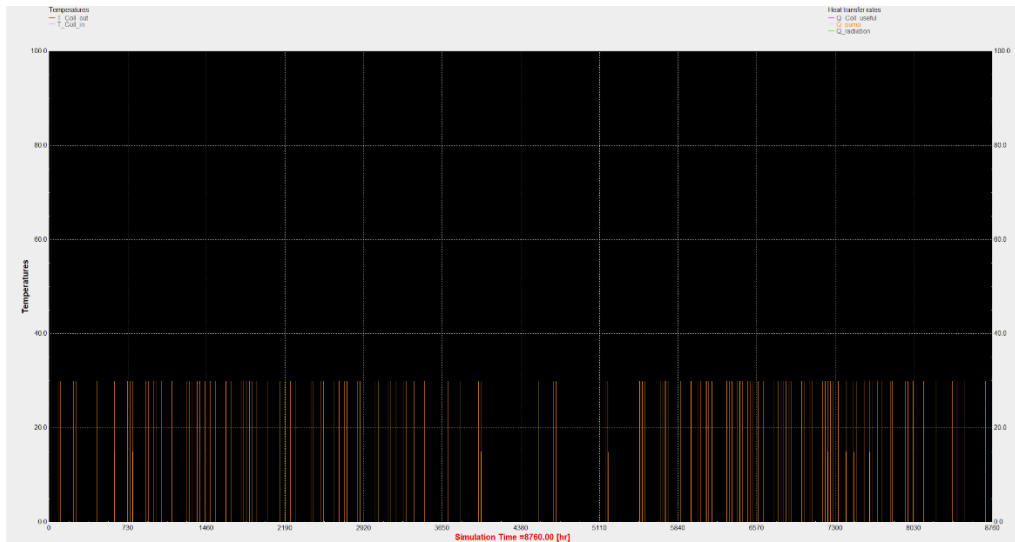


Fig. 5. Electricity used by the pump of the solar system in kJ/h

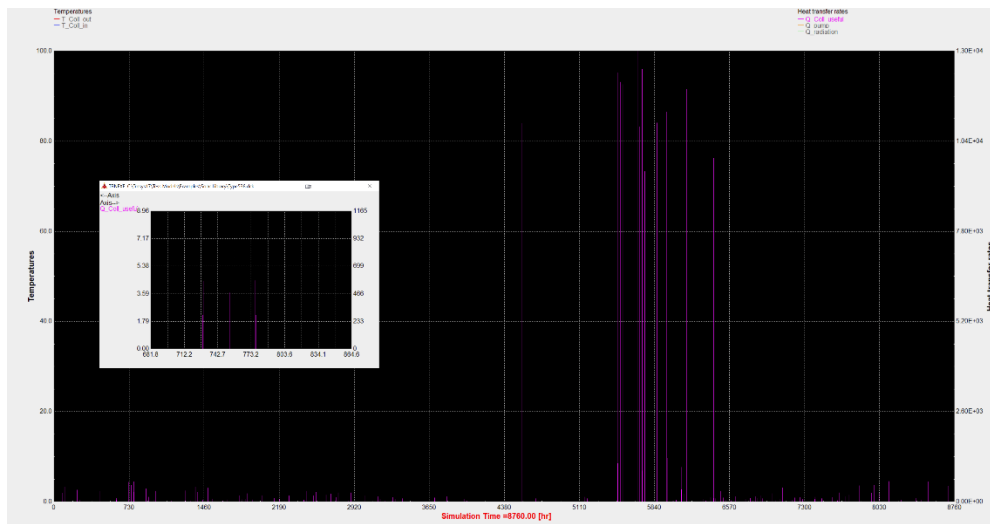


Fig. 6. Useful heat exchange from solar collector

In first part of year (first six months) and in last three months of the year, the amount of useful heat given through solar collector is much smaller than in July, August, September, and explanation is really simple, those are the winter, fall and early spring months. Further more, the utilization of the solar system is also dependent on the control system and use of heat by the heat exchanger. Hence since the initial temperature of the tank is relatively high  $55^{\circ}\text{C}$ , the water is heated by the use of the heater, since the solar radiation is insufficient. In the summer period, the solar radiation is sufficient for the assumed consumption load, however, in the rest of the year it is utilized only when the temperature conditions are such, that the temperature is low enough to utilize solar energy, and the temperature in the solar collector in the same timestep is high enough for heating the tank(s). If this condition is not met, the tanks are heated by the heat exchanger – heater, resulting in poor effectiveness of the solar system, except in the hot summer months. On the figure you can see zoomed results for January period.

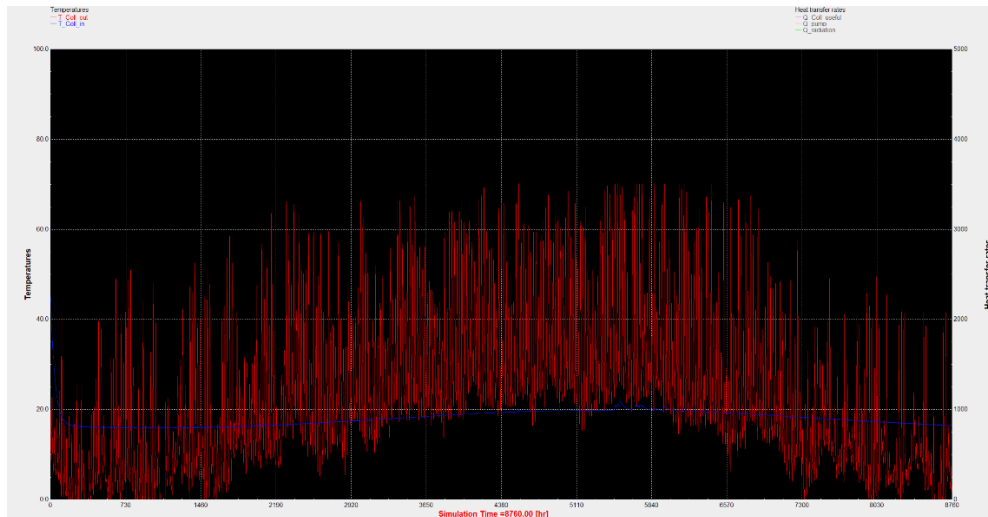


Fig. 7. Temperature inlet and outlet for Solar collector

As shown on figure 7, inlet temperature is practically the same through the year, no matter what time of day or year is, and as you can see on figure 7 that is not the case for outlet temperature. The inlet temperature is around 20 [°C], with small fluctuation in first three months of the year, and outlet temperature varies through the day, at night it is lower, and it depend what time of year it is. The highest outlet temperature is from May till September and it can go to 73[°C].

## Conclusion

In this paper, a review of the status of energy consumption in EU households is presented and analyzed. It is concluded that sanitary hot water accounts for almost 20% of the household electricity consumption. An annual simulation of the solar evacuated tube collector system with auxiliary heater is made for a typical meteorological year in Serbia. The simulation indicated that the design of the system and choice of hot water tank desired temperature level, as well as dynamics of the consumption and availability of the solar energy can strongly affect the effectiveness of the solar system. As the simulation results show, if the hot water tank temperature is set to high, solar collectors may provide insufficient heat flux for most of the year, except for the summer period. The solar systems are sized this way, i.e. based on the minimum heat demand in the hottest summer periods, to avoid the so called solar thermal system stagnation, which can lead to system damage. Therefore, for the high desired tank temperatures, the auxiliary heater is responsible for meeting most of the hot water energy demands. Different scenario can be expected in the case of lower desired tank temperatures, but this can be analyzed in some future research, and is omitted from this study.

**Acknowledgement:** This research was financially supported by the Ministry of Education, Science and Technological Development of the Republic of Serbia, according to contract No. 451-03-9/2021-14/200148.

## REFERENCES

- [1] Zavattoni, S., Garcia-Polanco, N., Capablo, J., Doyle, J., Barbato, M.: Household Appliances Wasted Heat Storage by means of a Packed bed TES with Encapsulated PCM“, 13th International Conference on Sustainable Energy technologies (SET2014), 25-28th August, 2014 Geneva
- [2] Eurostat, Energy consumption and use by households
- [3] Jovanovic, G., Živkovic, D., Mančić, M., Stanković, V., Stanković, D.: A model of a Serbian energy efficient house for decentralized electricity production, Journal of Renewable and Sustainable Energy 5, 041810 (2013), doi: [10.1063/1.4812997](https://doi.org/10.1063/1.4812997)

- [4] Golusin, M., Ivanovic, O.M., Bagaric, I., Vranjes, S.: Exploitation of geothermal energy as a priority of sustainable energetic development in Serbia, *Renewable Sustainable Energy Rev.* 14, 868 (2010).
- [5] Official Gazette of Republic of Serbia, No. 72/09, Ministry of Minings and Energy, Government of the Republic of Serbia, Belgrade, 2004.
- [6] Paatero, J.V., Lund, P.D.: A model for generating household electricity load profiles, *Int. J. Energy Res.* 30, 273 (2006).
- [7] Jovanovic, S., Djordjevic, Z., Bojic, M., Savic, S., Stepanovic, B.: Weather conditions impact on electricity consumption, *Proceedings Conference on Mechanical Engineering Technologies and Applications COMETA 2012*, Jahorina, Republic of Srpska, pp. 409–415, 28-30 November 2012.
- [8] EEA, 2018c, forthcoming, 'Progress on energy efficiency in Europe (ENER 037)' (<https://www.eea.europa.eu/data-and-maps/indicators/progress-on-energy-efficiency-in-europe-2/assessment-2>) European Environment Agency.
- [9] EC, 2016, Communication from the Commission to the European Parliament, the Council, the European Economic and Social Committee and the Committee of the Regions 'An EU strategy on heating and cooling' (COM(2016) 51 final) ([https://ec.europa.eu/energy/sites/ener/files/documents/1\\_EN\\_ACT\\_part1\\_v14.pdf](https://ec.europa.eu/energy/sites/ener/files/documents/1_EN_ACT_part1_v14.pdf)) accessed 14 February 2018.
- [10] EEA, 2018a, forthcoming, 'Final energy consumption by sector and fuel (CSI 027/ENER 016)' (<https://www.eea.europa.eu/data-and-maps/indicators/final-energy-consumption-by-sector-9/assessment-1>) European Environment Agency.
- [11] JRC, 2016, Energy consumption and energy efficiency trends in the EU-28 2000–2014 (<http://publications.jrc.ec.europa.eu/repository/bitstream/JRC101177/ldna27972enn.pdf>) accessed 14 February 2018.
- [12] Bertoldi, P., Hirtl, B. & Labanca, N.: *Energy efficiency Status Report 2012*”, s.l.: JRC - Joint Research Centre, 2012.
- [13] Programme, M. -. M. T., 2007. “BNC11: Domestic refrigerator test standard vs real-use energy consumption”, s.l.: s.n.
- [14] Programme, M. -. M. T., 2008. “BNCK01: Assumptions underlying the energy projections of cooking appliances”, s.l.: s.n.
- [15] Mančić, M., Živković, D., Milosavljevic, P., Todorovic, M.: Mathematical modelling and simulation of the thermal performance of a solar heated indoor swimming pool, *Thermal science*, Vol. 18, No. 3, pp. 999-1010, 2014.
- [16] [https://www.eea.europa.eu/data-and-maps/daviz/final-energy-consumption-households-per-capita-2#tab-chart\\_1](https://www.eea.europa.eu/data-and-maps/daviz/final-energy-consumption-households-per-capita-2#tab-chart_1).



## SONOMETRIC MEASUREMENTS IN AGRICULTURAL APPLICATIONS – CASE STUDY

Timotei Bogdan Bacos<sup>1</sup>, Adrian Eugen Cioabla<sup>1</sup>

<sup>1</sup>University Politehnica Timisoara, Faculty of Mechanical Engineering, Timisoara, Romania  
e-mail: [adrian.cioabla@upt.ro](mailto:adrian.cioabla@upt.ro)

**Abstract:** The present paper underline3s an experimental approach related to noise influence in agricultural vehicules. This small experiment studied the noise influence upon the driver in case of two different tractors and conclusions were traced regarding the potential influence, noise levels and parallel comparison for the two studied vehicles for one scenario.

**Key words:** agricultural vehicles, noise, comparative measurements

### INTRODUCTION

Pollution in the atmosphere isn't the only sort of contamination wreaking havoc on the planet's inhabitants. It is one of the most significant environmental risks to human health, according to the World Health Organization (WHO). Noise is also responsible for 16,600 early deaths and more, according to the European Environment Agency (EEA).

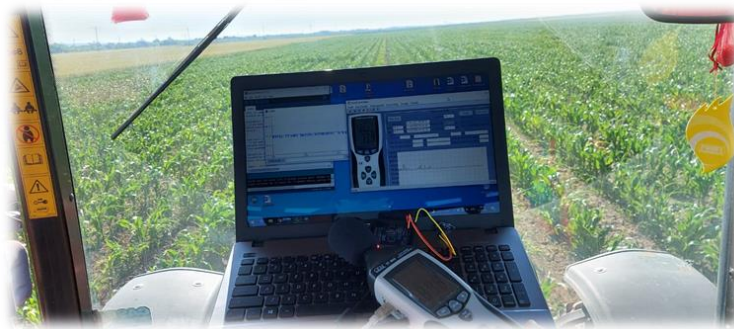


Fig. 1. Measurements on field.

Noise is detrimental when it surpasses 75 decibels (dB) and is uncomfortable when it exceeds 120 dB, according to the World Health Organization. Drivers blowing their horns, construction crews boring the road surface, planes passing overhead noise, noise and more noise. Cities have become the epicenter of a sort of pollution known as acoustics, which is extremely harmful to humans despite its invisibility and the fact that the coronavirus crisis reduced it to nearly zero.

Noise, according to the European Environment Agency, is responsible for 72000 hospital admissions and 16600 premature deaths in Europe alone each year [1].

It is not only harmful to humans, but also to animals. Noise pollution has a huge environmental impact and causes considerable ecological damage, according to the National Park Service (NPS) in the United States. Noise pollution, according to experts, can disrupt breeding cycles and rearing, as well as hastening the extinction of some species [2].

Noise pollution does not apply to all sounds. Noise pollution is defined by the World Health Organization (WHO) as noise that exceeds 65 decibels (dB). Noise becomes hazardous when it exceeds 75 decibels (dB) and painful when it exceeds 120 dB. As a result, it is advised that noise levels be kept below 65 dB during the day, and that nighttime ambient noise levels of more than 30 dB make it hard to have a good night's sleep [1].

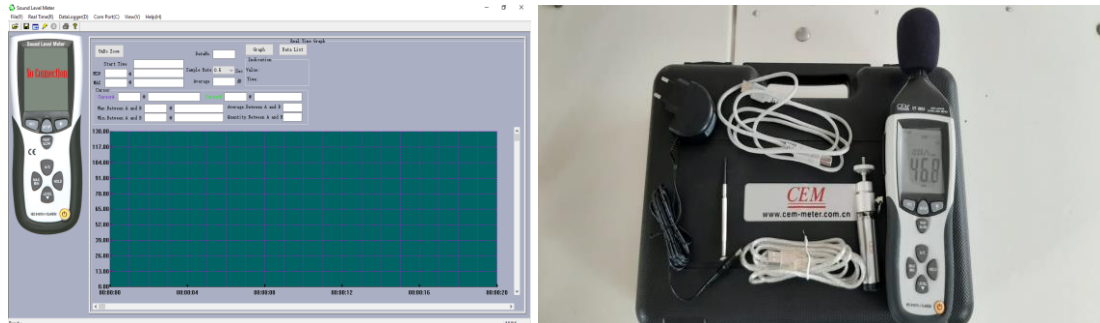
Noise from farm tools and machinery can cause permanent hearing loss and tinnitus. Repeated contact noise can cause permanent damage [3]. The damage may happen gradually over a few years and will not be noticed until it's too late. Noise is not necessarily painful to cause injury [4].

## MATERIAL AND METHODS

The used materials and equipment's are described below.

### 1. Sound Level Meter DT-8852

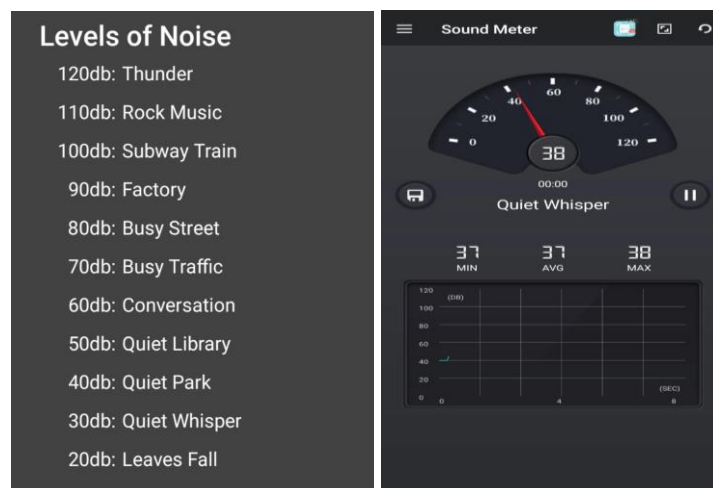
Sound level meters are frequently used in noise pollution studies to determine almost any type of noise, but especially for the industrial fields, environmental protection and airport noise.



**Fig. 2.** Sound Level Meter: Interface and tool bag.

### 2. Android App Sound Meter

The SPL (Sound Pressure Level) measurement application uses the built-in microphone to measure the volume of noise in decibels (dB), displaying a reference.



**Fig. 3.** App Sound Meter: Levels of noise and interface.

Two tractors were used for the study, basically a machines that provides machine power for performing agricultural tasks. Tractors can be used to pull various agricultural tools for farming, planting, cultivating, fertilizing, harvesting crops, and can also be used for hauling materials and personal transportation.

### 1. John Deere 3040

Built in 1981-1987 in Germany, this tractor was used in almost every field work. Engine 5.9L, 6 cyl diesel, which generates 92Hp.



**Fig. 4.** Tractor John Deere 3040

## 2. International 1055

Built between 1977-1981 in France for replacing and improving the human labor in agriculture farming. Engine 5.9L, 6 cyl diesel, which generates 100Hp.

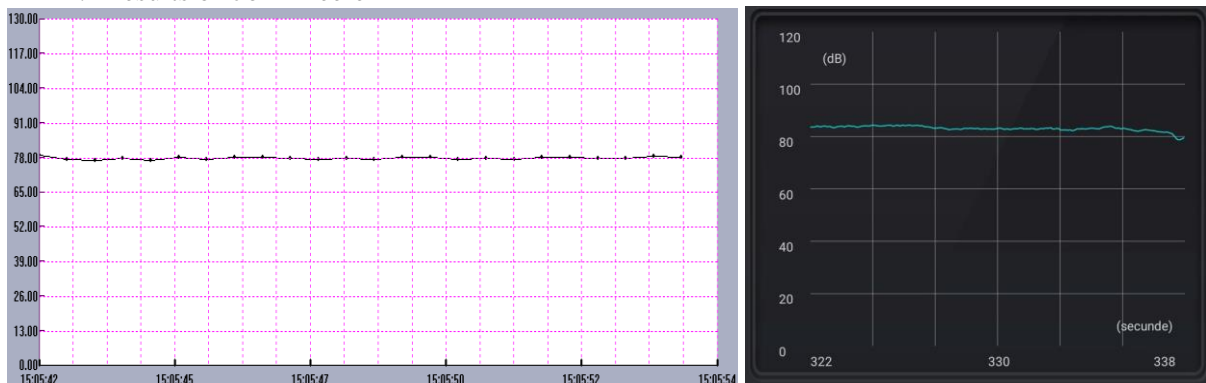


**Fig. 5.** Tractor International 1055

## RESULTS AND DISCUSSION

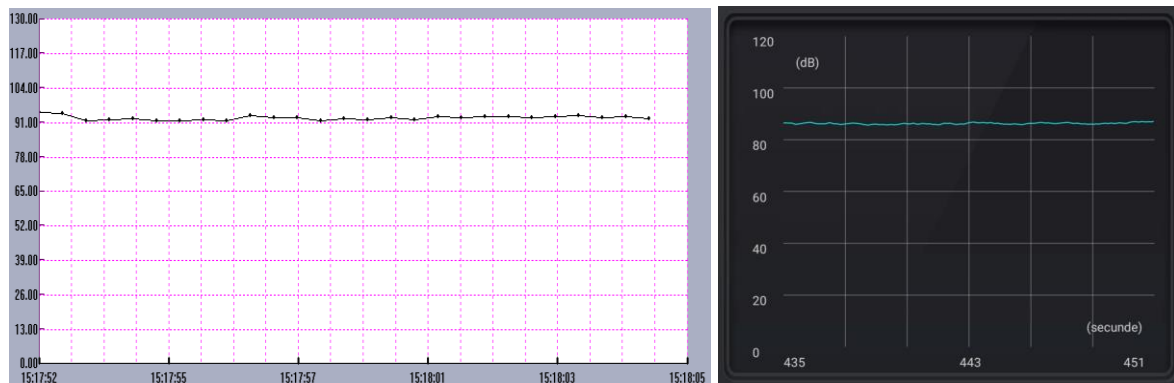
The measurements were performed at different times and in different places. The first series will be carried out in the cab, at the level of the driver's head, when the tractor is idling. The second set of measurements were performed outside the machine, as close as possible to the engine compartment, while it will perform the related work-John Deere agricultural task (fertilizing) and International vinicultural task (grapes transportation after harvest).

### 1. Results on John Deere



**Fig. 6.** Inside the cabin, engine idling measurements: Sound Level Meter (left). Noise exceeds 75 decibels (dB) / App Sound Meter (right). Noise exceeds 80 (dB)

From both equipment's used, it was determined that the average noise level for this trial was at an average of around 80 decibels, a relatively normal value for this type of vehicle. Comparative to the noise map described in different elements from literature, the level of discomfort for the driver is relatively manageable, without any supplementary devices to isolate the sound.

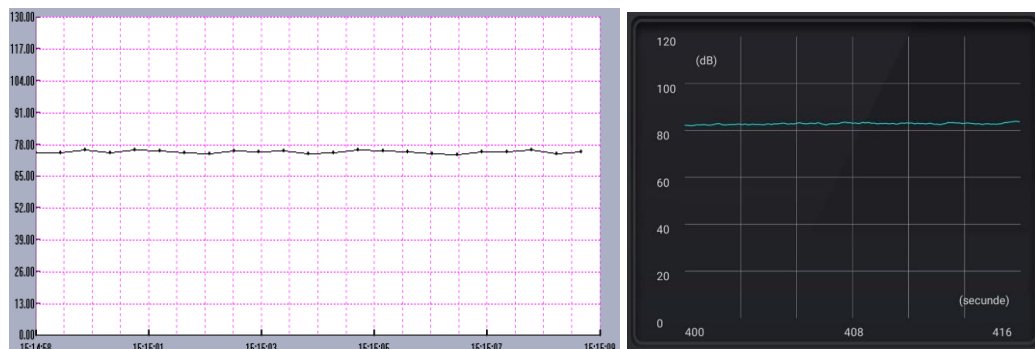


**Fig. 7.** Outside, near engine at full throttle and working measurements: Sound Level Meter (left). Noise exceeds 90 decibels (dB) / App Sound Meter (right). Noise exceeds 85 (dB)

The levels of noise outside, as expected were higher with around 10%, in the range for Diesel type engines.

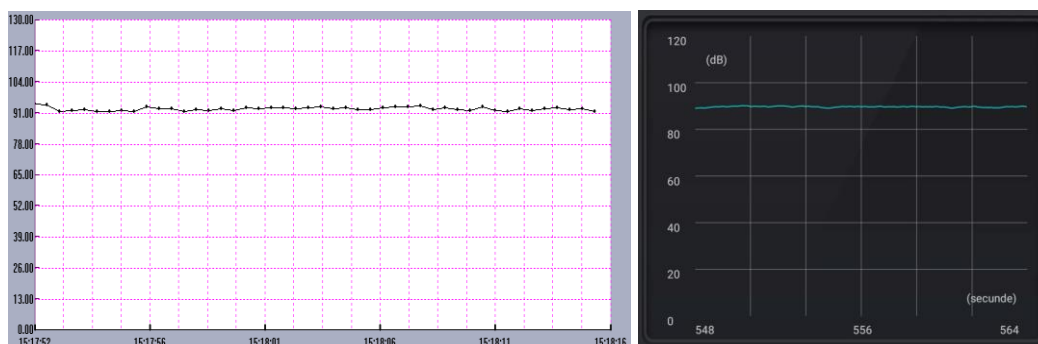
## 2. Results on International tractor

For the next vehicle, measurements were conducted in the same manner, and the results are described as follows.



**Fig. 8.** Inside the cabin, engine idling measurements: Sound Level Meter (left). Noise exceeds 75 decibels (dB) / App Sound Meter (right). Noise exceeds 80 (dB)

It was determined that the noise level is almost similar with the first tractor, for a mean value of around 80 dB.



**Fig. 9.** Outside, near engine at full throttle and working measurements: Sound Level Meter (left). Noise exceeds 91 decibels (dB) / App Sound Meter (right). Noise exceeds 92 (dB)

For the outside measurements, the values were again, in the same range as for the first tractor, even if the engine has more power, which represents a good indicator of the good insulation materials used on it and also shows a relative similitude of the two vehicles. The important role of this noise level is the engine type and capacity (diesel), and the obtained values show a moderate level of discomfort for the drivers in this initial work regime.

## CONCLUSION

The equipment of the machines drastically influences the propagation of the sound inside them. By their nature, work machines are polluting factors. Doors and windows seals play a crucial role in maintaining a sound threshold inside the vehicle. The construction of the cab is the most important factor when it comes to sound propagation to the machine operator. The fluctuations are due to uncontrollable external auxiliary factors as weather conditions, traffic, but also the shape and quality of the tread. The sound is perceived at a higher level outside the cab due to direct exposure to the noise source. The International tractor is more powerful, therefore more pollutant.

## REFERENCES

- [1] <https://www.iberdrola.com/environment/what-is-noise-pollution-causes-effects-solutions>
- [2] <https://www.nationalgeographic.org/encyclopedia/noise-pollution/>
- [3] Shannon, G, Mckenna, MF, Angeloni, LM, Crooks, KR, Fristrup, KM, Brown, E, Warner, KA, Nelson, MD, White, C, Briggs, J, Mcfarland, S, Wittemyer, G.: A synthesis of two decades of research documenting the effects of noise on wildlife, Biol Rev, No.91, pp. 982–1005, 2016
- [4] Hempton, G, Grossmann, J.: One square inch of silence: one man's quest to preserve quiet. New York City: Free Press/Simon & Schuster; 2009.

## PROBLEMS RELATED TO THE ELECTRIC POWER SYSTEM OF WIND FARMS AND NEW TENDENCIES IN THEM

Vladimir Šinik<sup>1</sup>, Željko Despotović<sup>2</sup>, Branko Radović<sup>3</sup>, Mića Đurđev<sup>1</sup>, Miloš Josimović<sup>1</sup>

<sup>1</sup>University of Novi Sad, Technical Faculty "Mihajlo Pupin", Zrenjanin, Serbia

<sup>2</sup>Institute „Mihajlo Pupin” Belgrade, Serbia

<sup>3</sup>Institute for Protection and Ecology of Republika Srpska, Banja Luka, Republika Srpska,  
BiH

e - mail: [sinik.vladimir@gmail.com](mailto:sinik.vladimir@gmail.com)

**Abstract:** The first part of the paper presents the problems of electricity production using wind farms. In the second part of the paper, new tendencies in the realization of wind farms are given. Power systems are complex systems that evolve over years in response to economic growth and continuously increasing power demand. In order to make energy economically available with reduced carbon emission using renewable energy sources, the structure of the modern power system has become highly complex.

**Key words:** Wind farms, power systems, connecting wind farms.

### INTRODUCTION

The annual energy production of a wind farm is not equal to the sum of the generator nameplate ratings multiplied by the total hours in a year since the wind speed is variable. The capacity factor of a wind farm is the ratio of actual productivity in a year to the theoretical maximum. The range of the capacity factor is between 20 and 40%, with values at the upper end of the range in particularly favorable sites. The rapid development of the wind turbine industry is going in two key directions - increasing power, through increasing the diameter of the rotor, or through increasing the coverage of kinetic wind energy, and increasing efficiency conversions through the improvement of converter circuits, ie active speed regulation and setting at the point of maximum power [1]. Electricity generated from wind power can be highly variable at several different timescales: hourly, daily, or seasonally. However, wind is always in constant supply somewhere, making it a dependable source of energy because it will never expire or become extinct. Annual variation also exists, but is not so significant. Like other electricity sources, wind energy must be scheduled. Wind power forecasting methods are used, but predictability of wind plant output remains low for short-term operation. Because instantaneous electrical generation and consumption must remain in balance to maintain grid stability, this variability can present substantial challenges to incorporating large amounts of wind power into a grid system [2], [3].

### POWER SYSTEM CONNECTION ISSUES OF WIND FARMS

Unlike classical sources of energy, wind farms supply real power variations into the upstream grid, and at the same time, in some types of wind generation systems, the reactive power consumption is related to the real power production. These power variations cause voltage variations with consequences for the electrical power system and the customers. On the other hand, the increasing use of power electronics in wind generation systems introduces voltages and current harmonics into the power system. As wind energy is a non-controllable energy source, it can cause problems with voltage stability and transient stability. Due to the rapid increase in the number of wind farms connected to the grid, the increasing rate of power of single wind farm and the weakness of the upstream power grid, where the wind farm connects, the importance and necessity of the study of wind farms connected to power systems is clear [3].

The connection of wind farm to electrical power systems influences the system operation point, the load flow of real and reactive power, nodal voltages and power losses [4].

The impact of wind farm on the power system depends on the location of wind power plants relative to the load, and the correlation between wind power production and load consumption. Wind power, like

any load or generation, affects the power flow in the network and may even change the power flow direction in parts of the network. The changes in the use of the power lines can bring about power losses or benefits. Increasing wind power production can affect bottleneck situations. Depending on its location, wind power may, at its best, reduce bottlenecks, but at another location result in more frequent bottlenecks. Grid extensions are commonly needed if new generation is installed in weak grids far from load centers to make full use of the wind power. The issue is generally the same for modern wind power plants or any other power plants. The cost of grid reinforcements, due to wind power, is therefore very dependent on where the wind power plants are located relative to the load and grid infrastructure, and one must expect numbers to vary from country to country. With current technology, wind power plants can be designed to meet industry expectations such as riding through voltage dips, supplying reactive power to the system, controlling terminal voltage, and participating in SCADA (supervision control and data acquisition) system operation with output and ramp rate control [4, 5].

## **DIFFERENT WIND TURBINE TECHNOLOGIES**

There are many different generator types for wind power applications in use today. The main distinction can be made between fixed speed and variable speed wind generator types. Previous solutions with asynchronous machines of cage or sliding type with constant or partially regulated operating speeds are not sufficiently energy efficient and can hardly meet the increasingly complex network requirements given in the "Rules for the operation of power systems" [5]. Also, the issues of reliability and reduction of maintenance costs, especially for offshore wind farms, are becoming increasingly important, so new solutions are being sought for more efficient use of wind energy through the growing role of power electronic converters as interfaces between generators and grid, and operation without mechanical speed multipliers. The rapid development of the wind turbine industry is going in two key directions - increasing power, through increasing the diameter of the rotor, or through increasing the coverage of kinetic wind energy, and increasing efficiency conversions through the improvement of converter circuits, ie active speed regulation and setting at the point of maximum power [1], [5].

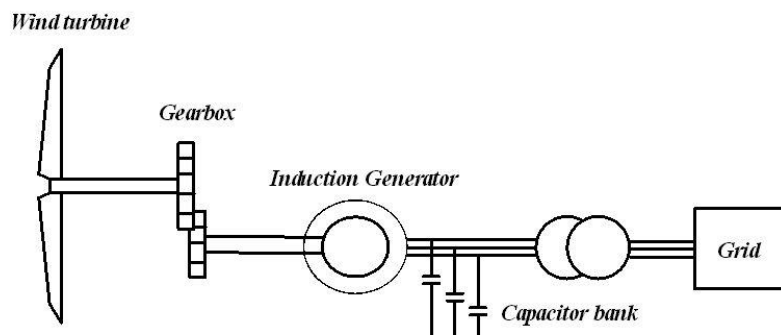
Wind turbines started as small generator units of several tens of kW and with a symbolic role in the power system. However, they developed very quickly and in the previous decade, units of several MW became commonplace. Power generators are currently appearing on the market 6 - 8 MW, with the planned development of 10 MW units with a vision to increase to as much as 20 MW [6].

In a continuous effort to reduce costs, increase the reliability and efficiency of wind energy conversion systems, various solutions have been developed. In general, wind turbines can be classified as fixed and regulated speed turbines [1], [8]. Fixed speed wind turbines use a cage asynchronous generator connected directly to the grid. To start, thyristor energy converters are used in the "soft start" configuration, which are in nominal mode short-circuited. This method forces the electric machine to operate at a constant frequency and therefore at an approximately constant speed. Wind power pulsations are transmitted directly to the grid and there is no control of active and reactive power, which are typically important parameters for frequency and voltage regulation. Network connection and difficulties in complying with the "Power System Rules" are additional problems. On the other hand, these solutions are simple, robust and use existing, already developed technology, so they are affordable. An improved solution with a synchronous generator with permanent magnets and a converter circuit connected in an open stator hub, enables active damping with relatively low converter power (20% of the nominal power of the generator) [1], [8]. However, that solution remained at the level of an academic proposal and outside the interests of the industry. Fixed speed wind turbines were mainly used in the first days of using wind energy and are characterized by low power. Greater interest in the application of wind generators and stronger investment cycles, have led to the search for solutions to remove the above limitations, ie to the development of the application of structures with regulated speed. Speed-regulated turbines provide better power utilization and are easier to adapt to network needs.

Synchronous generators and asynchronous cage generators connected to the energy conversion system are used in practical embodiments of these wind turbines. In addition, sliding-reel machines, such as double-powered asynchronous generators with reduced converter power or asynchronous generators with external controlled rotor resistance, have practical applications [1], [7].

Due to the variability of wind speed, it is highly desirable that the turbine drive be of variable speed. Also, with the increase of turbine power, control parameters become more and more important, so it is necessary to implement power electronics as an interface between the wind turbine and the network. The turbine is with variable speed it improves the dynamic behavior of the turbine and enables propulsion with maximum power at a certain wind speed and control of the flow of active and reactive power. Other benefits are reduced mechanical stress, less torque and power pulsations, improved voltage quality and less noise at low wind speeds [1], [5]. Based on the use of the transmission mechanism, they can be divided into turbines with direct or indirect drive. Both solutions of a synchronous generator with a wound rotor or with permanent magnets are acceptable for direct drive, for which a full energy converter system is required. Asynchronous cage generators can also be used, also with the use of a back-to-back converter system. This system serves as an interface between the generator and the network and consists of a diode or active rectifier, a DC link and a network inverter. The generator speed is adjusted turbine speed and thus the transmission mechanism is of minor importance and can be eliminated. In wind turbine systems with multi-pole (eg 72-pole) or multi-phase configurations (for example phase 6) synchronous generators a mechanical multiplier can be eliminated [1]. This is especially true when the generator is running at low speed, ie. has a large number of poles. Such a turbine without a mechanical multiplier (transmission mechanism) is attractive due to lower cost, weight and significantly lower maintenance costs. Multiphase or multi-winding generators are interesting for research also because such a topology increases the reliability of the whole system, and with the appropriate design of switching schemes, the influence of harmonics on the network can be significantly reduced [1]. Indirect-driven turbines require a transmission mechanism to synchronize low-speed turbines with high-speed generators. Another possible classification reflects the application of converter systems based on energy electronic converters. There are wind generator systems with partially regulated speeds and full speed regulation.

In the early stage of wind power development, most wind farms were equipped with fixed speed wind turbines and induction generators. A fixed speed wind generator is usually equipped with a squirrel cage induction generator whose speed variations are limited. Power can only be controlled through pitch angle variations. Because the efficiency of wind turbines depends on the tip-speed ratio, the power of a fixed speed wind generator varies directly with the wind speed. Since induction machines have no reactive power control capabilities, fixed or variable power factor correction systems are usually required for compensating the reactive power demand of the generator. Fig. 1. shows the schematic diagram of the fixed speed induction machine [3].



**Fig. 1.** Fixed speed induction generator [3]

Variable speed concepts allow operating the wind turbine at the optimum tip-speed ratio and hence at the optimum power coefficient for a wide wind speed range. The two most widely used variable speed wind generator concepts are the DFIG and the converter driven synchronous generator. Due to



advantages such as high energy efficiency and controllability, the variable speed wind turbine using DFIG is getting more attention. DFIG is basically a standard, wound rotor induction generator with a voltage source converter connected to the slip-rings of the rotor. The stator winding is coupled directly to the grid and the rotor winding is connected to power converter as shown in Fig. 2.

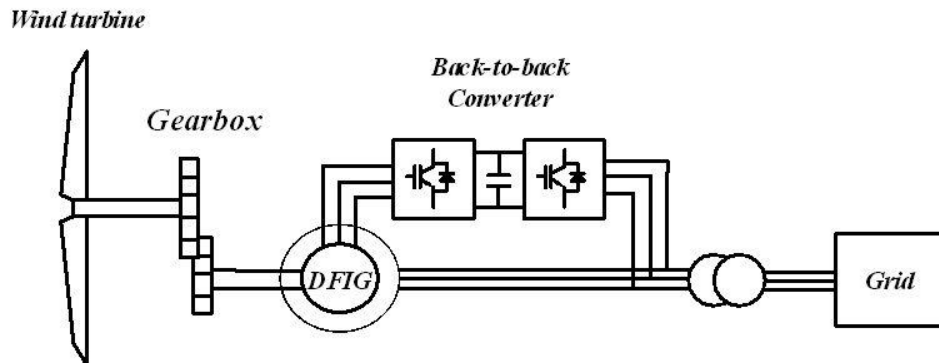


Fig.2. Double fed induction generator [3]

The converter system enables two way transfer of power. The grid side converter provides a dc supply to the rotor side converter that produces a variable frequency three phase supply to generator rotor via slip rings. The variable voltage into the rotor at slip frequency enables variable speed operation. Manipulation of the rotor voltage permits the control of the generator operating conditions. In case of low wind speeds, the drop in rotor speed may lead the generator into a sub synchronous operating mode. During this mode, DFIG rotor absorbs power from the grid [3].

This category of wind turbines uses a synchronous generator that can either be an electrically excited synchronous generator or a permanent magnet machine. To enable variable-speed operation, the synchronous generator is connected to the network through a variable frequency converter, which completely decouples the generator from the network. The electrical frequency of the generator may vary as the wind speed changes, while the network frequency remains unchanged. The rating of the power converter in this wind turbine corresponds to the rated power of the generator plus losses. The schematic diagram of the converter driven synchronous generator is as shown in Fig. 3.

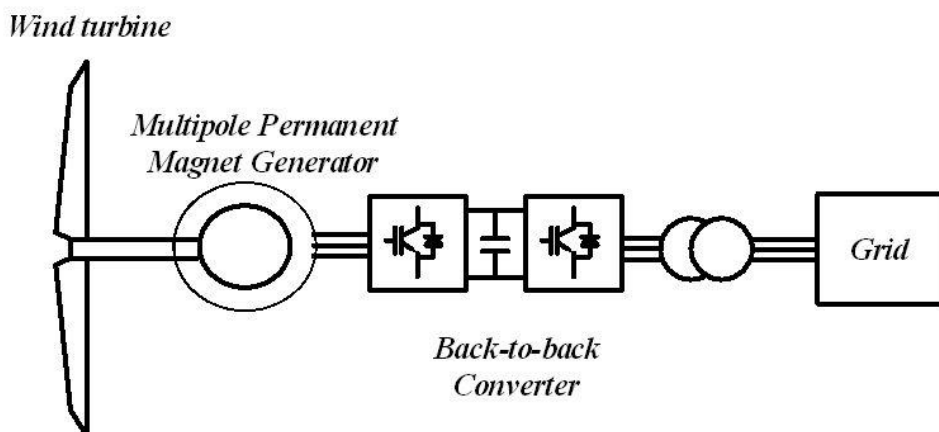
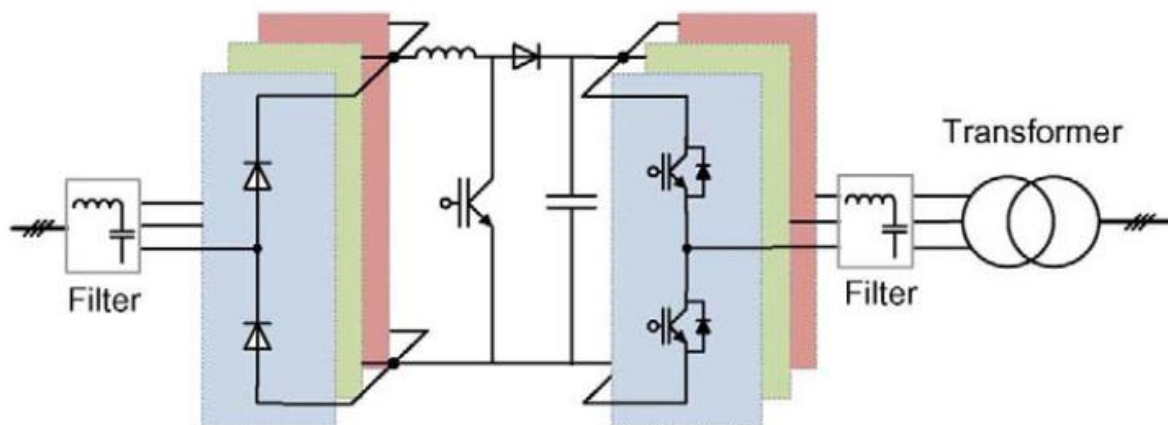


Fig. 3. Converter-driven generator

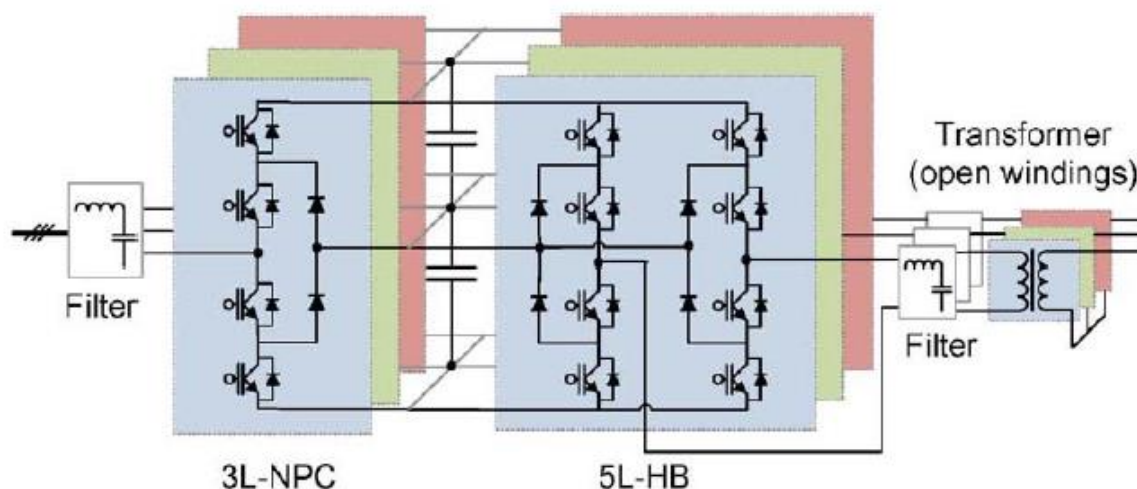
A wind generator with a synchronous generator (SG) has a number of possible configurations, because SGs can produce rotor flux independently. Instead of an active rectifier on the generator side, a cheaper diode rectifier with a voltage boost converter can be used in the DC link (Fig. 4). However, for higher power the voltage booster must be composed of several intertwined units or in some other way.



**Fig. 4.** Converter assembly with diode rectifier, boost voltage converter and voltage rectifier [1]

Medium voltage electric generators and adequate converters are used for higher power wind generators (10 MW). The problem is the high voltage stress of the electronic switching components, however components must bind to the row.

New solutions for higher power converters include the use of multilevel converters. 3-level, 5-level inverter variants are possible, as well as combinations of these solutions in a half-bridge or bridge configuration. Fig. 5. shows a solution with a 3-level rectifier and a 5-level inverter in a half-bridge configuration. In addition to the problem with the voltage fluctuation of the midpoint, which is on the way to a solution, a serious drawback is the uneven distribution of losses in the branches of the converter.



**Fig. 5.** Dual converter with 3-level rectifier and 5-level inverter [1]

For wind generators, it is possible to use converters with several connected smaller units, which is more convenient considering the voltage levels of the switching electronic components themselves. Unlike variants with double converters, solutions with indirect or direct AC / AC converters are proposed here. Figure 6 shows two possibilities: an indirect converter and a direct (matrix) converter. An indirect converter is a combination of AC / DC, DC / AC, AC / AC, AC / DC and DC / AC series-connected converters, with the AC / AC converter being in fact an isolating transformer, operating at medium frequencies. A matrix converter is a complex unit, which requires an isolating transformer with a larger number of primary windings. Other solutions are possible, which include a large number of differently parallel or series-connected converters with a large number of switches. However, due to the many components, the issue of system reliability comes to the fore, so complex analyzes of possible outages and maintenance methods are needed [1].

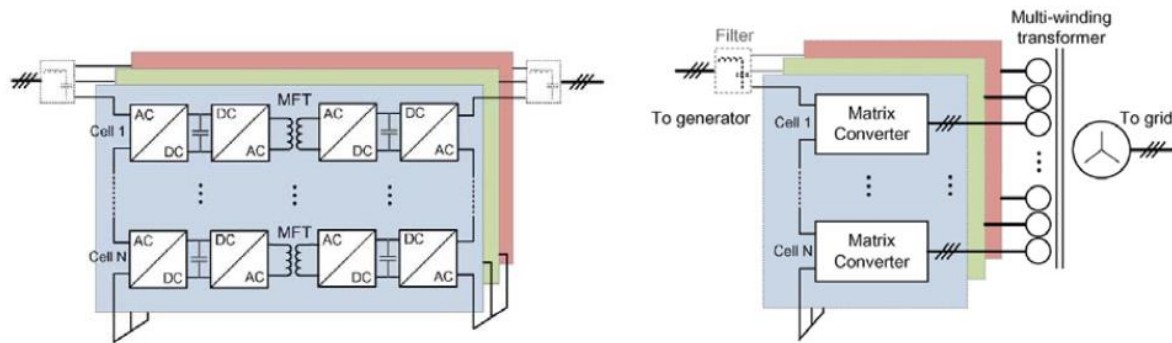


Fig. 6. Indirect and direct AC / AC converters for wind turbines [1]

## IMPACT OF WIND INTERMITTENT AND VARIABILITY

Uncertainty and variability are characteristics that exist in wind power, aggregate electric demand and supply resources and have always posed challenges for power system operators. Future expansion of the loads cannot be predicted accurately, generator outputs and loads fluctuate strongly in different time frames, and it can also lose energy system equipment at any time and without prior warning. Different amounts and types of operating reserves are secured by power system operators to compensate for uncertainty and variability for load reliable service and to keep the system frequency stable. There are many different terms, definitions, and rules concerning what operating reserves entail. The real power capability that can be given or taken in the operating timeframe to assist in generation and load balance and frequency control is defined as the operating reserves. To provide voltage support systems also require reactive power reserve as well, and require certain targets for installed capacity that is often referred to as planning reserve [3].

The type of event the operating reserves respond to, the timescale of the response and the direction (upward or downward) of the response can differentiate the types of operating reserves. Unpredictable imbalances between load and generation caused by sudden outages of generating units, errors in load forecasting or unexpected deviations by generating units from their production schedules can be compensated by spinning reserve (SR). It becomes more difficult to predict accurately the total amount of power injected by all generators into the power system, as the proportion of power produced by wind farms increases. This added uncertainty must be taken into account when setting the requirement for SR. The uncertainty on the wind power generation increases the uncertainty on the net demand that must be met by traditional forms of generation if wind power generation is considered as a negative load. Spinning reserve is intended to protect the system against unforeseen events such as generation outages, sudden load changes or a combination of both by taking the increased uncertainty into account when determining the requirements for SR [3].

## CONNECTION OF THE WIND POWER PLANT TO THE NETWORK

Each power system operates in accordance with certain rules that define the obligations of existing and future users to operate and connect to the power grid [1,4]. These requirements must be met by electricity producers, consumers connected to the electricity grid and grid management companies. These rules are known as the "Rules of Procedure power system "(Grid Code). Similar to transmission networks, the distribution network determines the requirements for connection of its users in the "Rules of operation of the Distribution Network" (Distribution Code) [1]. Compared to transmission network users, distribution network users have less power and less impact on the operation of the network, so that the requirements of the Rules of Operation of the Distribution Network are significantly easier compared to transmission. The fact is that the requirements of the "Rules of operation of the power system" are constantly adapted to the development of technology. These include fault issues, active power regulation, frequency, reactive power regulation, voltage regulation and production planning.

Wind farms are connected to the electricity grid, depending on the power: for installed power over 15 MW, farms are connected mainly to the transmission network, while for power below 15 MW they are connected to the distribution network. Since wind farms can have a significant impact on the quality of electricity and the stability of the power system, their installation, activation and operation are a significant problem. In that sense, technical ones are prescribed rules for connection of wind farms in the Rules for the operation of power systems (Grid Code). Wind turbine technology is evolving rapidly and has a lot of special functionalities compared to conventional power plants. For this reason, in many countries the requirements for joining farms wind generators have a special treatment in the form of special rules (Wind Code) [1].

## CONCLUSION

The changing nature of a power system has considerable effect on its dynamic behaviors resulting in power swings, dynamic interactions between different power system devices and less synchronized coupling. The general requirements of most of the leading Rules on the operation of the system (Grid Code) in the part of connecting wind farm farms, include the problem of failures, regulation of active power, frequencies, regulation reactive power and voltage, which are analyzed in this paper. On the other hand, modern constructions of wind generators enable cost reductions and increased reliability. In future high-power units, quality and reliable solutions of power electronics converters will play a key role in the electrical part. Further progress and significant improvements are expected in this area.

## REFERENCES

- [1] Katić, V., Dumnić, B., Milićević, D., Grabić, S., Čorba, Z., Katić, N.: Fakultet tehničkih nauka, Novi Sad. 2013
- [2] American Wind Energy Association "20% Wind Energy by 2030" 2009.
- [3] Abo-Khalil, A.: Impacts of Wind Farms on Power System Stability, Modeling and Control Aspects of Wind Power Systems, March 2013, DOI: [10.5772/55090](https://doi.org/10.5772/55090).
- [4] Eolic Energy News, "Spain becomes the first European wind energy producer after overcoming Germany for the first time", Dec. 2010.
- [5] JP Elektromreže Srbije, Pravila o radu prenosnog sistema, verzija 1, od 15.04.2008. god. [http://www.ems.rs/pravila\\_o\\_radu\\_prenosnog\\_sistema.pdf](http://www.ems.rs/pravila_o_radu_prenosnog_sistema.pdf).
- [6] Fichaux, N., et al.: Up Wind – Design limits and solutions for very large wind turbines, EWEA, March 2011, [www.ewea.or](http://www.ewea.or)
- [7] Bin, W., et al.: Power Conversion and Control of Wind Energy Systems, John Wiley and Sons, Inc., Publication, New Jersey, USA, 2011.
- [8] Grabić, S., Čelanović N., Katić V.: Permanent Magnet Synchronous Generator Cascade for Wind Turbine Application, IEEE Trans on Power Electronics, Vol. 23, No.3, pp. 1136-1142 May 2008.

## UNSUSTAINABLE DEVELOPMENT AND AGRICULTURE

Radovan Pejanović<sup>1</sup>, Marijana Dukić-Mijatović<sup>2</sup>, Jelena Ješić<sup>3</sup>

<sup>1</sup> University of Novi Sad, Faculty of Agriculture, Novi Sad, Serbia

e-mail: [pejanovic@uns.ac.rs](mailto:pejanovic@uns.ac.rs)

<sup>2</sup> University of Novi Sad, Faculty of Technical Sciences, Novi Sad, Serbia

e-mail: [marijana.mijatovic@uns.ac.rs](mailto:marijana.mijatovic@uns.ac.rs)

<sup>3</sup> University Educons, Faculty for Business Economy, Novi Sad, Serbia

e-mail: [jelena.jessic@educons.edu.rs](mailto:jelena.jessic@educons.edu.rs)

**Abstract:** The authors discuss the problems of the current concept of agricultural development and food production. The negative effects of unsustainable development on the environment and human health are emphasized. The authors advocate the application of a new concept of sustainable development, which includes a new economy, safe food and organic food production.

**Key words:** unsustainable development, problems of agriculture and food production, sustainable development, green economy, organic agriculture

### INTRODUCTION

The current concept of unsustainable development has led, among other things, to serious problems in agriculture and food production. The negative effects of conventional agriculture so far are numerous: erosion and degradation of agricultural land; increased use of fertilizers; increased use of pesticides; irrational use of water resources; use of antibiotics and stimulants and negative effects of livestock production; use of GMOs as controversial biotechnology; climate change.

The consequences of all this are the problem of food safety. Danger is a biological, chemical or physical substance in food or a condition of food that can cause harmful consequences for human health. In addition to these hazards, chemical contaminants also pose a risk: heavy metals, industrial pollutants, drugs and microtoxins. Chemical contaminants include, also, plant protection products.

Radical changes are needed at all levels. Economics has taken over that historical task: through the concept of the so-called new economies are increasingly striving to achieve that goal. An important segment of the new economy is the green economy, which should provide the concept of sustainable agricultural production, as opposed to the previous concept of unsustainable development. Sustainability implies the necessity to protect the environment in intensive plant and livestock production.

Green economy (Green agriculture) is one of the most promising global development concepts, which should be especially evident in agriculture and the production of health-safe food. In this regard, it is important to follow and implement EU strategies within the framework of the "Green Deal". It is especially important to develop organic agriculture.

### MATERIAL AND METHODS

The current paradigm of development is based on *homo economicus*, which is driven by profit motivation. It is the aspiration of people to make a profit with their economic activity, at any cost, and thus increase their wealth. Profit is considered a legitimate human initiative and the main driver of initiative and progress in all areas, including agriculture.

Capitalism introduced the agrarian revolution in agriculture, as a process of accelerated improvement of agricultural production by applying a high degree of mechanization, chemicalization and new methods of land cultivation, as an expression of the desire to maximize yields. This industrialization of agriculture causes numerous negative consequences for agriculture, land and food, as well as accelerated changes in the countryside (rural exodus and deagrarianization). Changes are needed in the direction of a new growth paradigm based on the concept of sustainable development, which is reflected in agriculture through health, safety and organic food production.

The key issue of further socio-economic development, and in this context agriculture and food, is the issue of a new concept of sustainable development, and in connection with the new economy. These are new patterns of thinking and behavior, which include, above all, the so-called. Green business, ie. The concept of a green economy, which is in line with the necessity of sustainable development. Business, including agribusiness, must, in fact, respect environmental principles, as well as the principles of business ethics, in the function of protecting man, society and nature from the consequences of unsustainable development so far.

Development of mass agricultural production for the market, consequence of division of labor, increasing specialization in agriculture and animal husbandry, breakdown into various branches of agricultural production. Along with that, there was professional training of farmers, more perfect use of agricultural machinery, selection of seeds, animal breeds, improvement of agricultural techniques, etc. In a relatively short time (from the beginning of the 19th century), numerous inventions made it a chemical fertilizer - Chilean saltpetre, phosphate, ammonia sulfate, etc. - became the main feature of agriculture in Europe and the world. This is the beginning of modern industrial food production (conventional agriculture), with all the positive (hyperproduction of food), but also negative effects (geological destruction of land, water, the problem of food safety, etc.). Global warming, namely, causes severe meteorological (climate) disturbances that threaten the biobalance on the planet Earth. The current conventional agriculture also contributes to this.

## RESULTS AND DISCUSSION

Since the beginning of civilization, most people have been engaged in agriculture. Today, in the first half of the 21st century, half of the world's population lives in rural areas and has ties to agriculture. Agriculture is the main source of livelihood for as many as 70 percent of the world's poor, living in rural areas and predominantly in developing countries. Human impact, however, has led to unsustainable environmental consequences.

The global agricultural system not only crosses planetary boundaries but also has other negative consequences. One of the problems is that the system of food production and use encourages, among other things, the emergence of new pathogenic germs (dangerous viruses such as the frightening SARS viruses from 2003, and the corona virus - Covid 19 from 2020).

The agrarian revolution, which lasted from the 50s to the 80s of the last century, led to the fact that the impact of agriculture on the environment is greater than it seems at first glance. The agrarian revolution, namely, introduced science, primarily agricultural chemistry, into agricultural production (chemicalization and mechanization of agriculture), which led to the industrialization of agriculture.

From that time until today, the impact of agriculture on the environment is manifested in several ways:

- By clearing the land for their cultivation (carbon dioxide emissions contribute to climate change, there is erosion and degradation of agricultural land);
- Use of artificial fertilizers, which are the main source of anthropogenic leakage of nitrogen and phosphorus;
- Agricultural production also leads to chemical pollution (using artificial fertilizers, pesticides, herbicides, etc.);
- Refrigerants used in food production and storage destroy the ozone layer;
- Monocultural agriculture causes a great reduction in biodiversity. It is about growing only one crop in an agricultural area, as a consequence of the process of specialization and profitability of agricultural production. Continuous cultivation of one plant species in the same field (field) for more than one year (vegetation season) has a multiple negative effect on the conditions of plant cultivation. Namely, it has an unfavorable effect: on the physical properties of the soil; on the one-way utilization of nutrients; contributes to the spread of weeds, diseases, pests, etc.

Modern food production is therefore based on the inputs of intensive agriculture, which means that it largely depends on fertilizers, pesticides, irrigation systems and machinery. And all that, again, depends on the **energy of fossil fuels**. It is a key factor in climate change, which has catastrophic consequences for agriculture and food production.

## CONCLUSION

### **Instead of a conclusion: the necessity of sustainable development of agriculture and food production**

The unsustainable concept of homo economic growth is leading humanity to ruin. Scientists from MIT (USA) warned about this danger in the cult book "Growth Limits" in the 70s of the last century. From then until today, politicians meet, discuss, state, declare and do not solve anything.

Changes are needed in the direction of a new development paradigm in all areas, including agriculture and food production. The economy is faced with the imperative of realizing the concept of sustainable development. Economics has already taken over this historical task through the concept of the so-called new economies. An important segment of the new economy is the green economy, which should ensure the realization of the concept of sustainable agricultural production, as opposed to the previous concept of unsustainable development. Sustainability implies the necessity to protect the environment and human health in intensive plant and livestock production. When it comes to climate change, it is about the need to respond to climate change with new technologies in agricultural production (precision agriculture, etc.)

The EU's "Farm to Table" strategy under the "Green Deal" emphasizes that "food must be safe, nutritious and of high quality". It must be produced with minimal impact on nature. In this regard, a special place and role is occupied by organic food production.

## REFERENCES

- [1] Atali, Ž., Gijom, M.: Economic science and problems of the human environment, antieconomics, IEP, Belgrade, 1987.
- [2] Brljak, Z., Ješić, J., Miladinov, Z.: Digital agriculture as a factor of energy efficiency and environmental protection, Yours 2020 Abstract Proceedings, YOUng ResearcherS Conference 2020, 28th September 2020, Institut za istraživanja i projektovanja u privredi, Belgrade, 2020.
- [3] Drašković, B.: Natural capital economics, IEN, Belgrade, 1998.
- [4] Donella, H. at all: Growth limits, Stvarnost, Zagreb, 1974.
- [5] Gorc, A.: Ecology and politics, Prosveta, Belgrade, 1982.
- [6] Haris, M. Dž.: Environmental economics and natural resources: a modern approach, Data status, Belgrade, 2006.
- [7] Havranek, J. et all: Food safety from the field to the table, M.E.P. doo, Zagreb, 2015.
- [8] Njegomir, V., Marović, B., Pejanović, R., Kuzmanović, B.: Climate change and insurance of agriculture, Princip Pres, Belgrade, 2017.
- [9] Filipović, M., Vujošević, M.: A new generation of European documents for sustainable development, lessons for Serbia, CID, Ekonomski fakultet I IAUS, Belgrade, 2008.
- [10] Karavidić – Čukanović, M., Dukić – Mijatović, M., Pejanović, R., Karavidić, S.: Education for sustainable development, monograph, Službeni glasnik, 2021.
- [11] Ješić, J., Vukadinović, S.: Eco-innovation indicators as indicators of green economy and sustainability of development, Mefkon 2019, Innovation as an initiator of the development "innovations – development prospects", International Thematic Monograph – Thematic Proceedings, Faculty of Applied Management, Economics and Finance, Belgrade, 2019, p. 378-393.
- [12] Pejanović, R.: Experiments in agrarian and rural economy, Poljoprivredni fakultet, monograph, Novi Sad, 2013.
- [13] Pejanović, R.: On the development problems of our agricultural economy, the state and perspectives of agribusiness in Serbia, Zbornik radova, Ekonomski fakultet, Belgrade, 2016, p. 69-91.
- [14] Pejanović, R.: Development problems of the economy and society, monograph, Akademska knjiga, Novi Sad, 2017.
- [15] Pejanović, R.: Challenges of economic education, monograph, Akademska knjiga, Novi Sad, 2019.
- [16] Pejanović, R., Ješić, J.: Challenges of (non)Sustainable Development, GEA (Geo Eco EcoAgro), International Conference, Book of Abstracts, Podgorica, Montenegro, 2020, p. 38.

- [17] “Zeleni dogovor” EU (“Green Deal”) – <http://ec.europa.eu>.  
[18] [www.gea.ucg.ac.me](http://www.gea.ucg.ac.me)  
[19] [www.agrosens.rs](http://www.agrosens.rs)



## OPERATING MODELS FOR PV SYSTEMS IN EXISTING RESIDENTIAL BUILDING COMPLEXES IN VIENNA – CHALLENGES AND OPPORTUNITIES

Momir Tabakovic<sup>1</sup>, Marlen Würfl<sup>1</sup>, Eduardo Guerra<sup>1</sup>, Miriam Gutleder<sup>1</sup>

<sup>1</sup>University of Applied Sciences Technikum Wien, Vienna, Austria

e-mail: [nomir.tabakovic@technikum-wien.at](mailto:nomir.tabakovic@technikum-wien.at)

**Abstract:** This paper aims to identify challenges and opportunities that are associated with installing PV (Photovoltaic) systems in existing residential building complexes in Vienna. For this purpose, a project-oriented approach was chosen and hence a representative residential building complex in Vienna was chosen and analyzed to demonstrate the challenges that are associated with such projects. Furthermore, a particular focus lies on exploring different operating models that are available when it comes to the execution of such a project. As this paper builds on the rather novel topic of exploring new operating models for installing PV systems on existing residential building complexes in Vienna, many further suggestions for research can be identified that exceed the scope of this paper.

**Key words:** photovoltaic systems, urban areas, renewable energy, energy communities.

### INTRODUCTION

Climate protection measures in the building sector are one of the most important levers for achieving climate goals in urban areas. The building sector causes around 17% of all greenhouse gas emissions in Vienna. At the same time, however, buildings in urban areas offer enormous potential for the expansion of photovoltaic systems and charging infrastructure for electric cars. Vienna aims at significantly increasing the amount of solar energy in the next years. Therefore, a new construction regulation was introduced in 2020, stating that from now on, PV systems must be installed on all new buildings [1]. However, one of the biggest challenges will be how to retrofit existing buildings so that they meet future energy standards since only about 13% of all buildings in Vienna were built after 2000 [2]. To gain insights into the challenges and solutions that are prevalent when it comes to retrofitting existing buildings, an exemplary property in Vienna was chosen to investigate this topic. The chosen apartment complex is located on the outskirts of Vienna. As a typical apartment community, it is an exemplary case for many other buildings in Vienna. About 29% of all buildings in Vienna were built between 1971 to 1990 and can therefore be prime example for other multi-unit apartment buildings [2].

At the exemplary property, the research project aimed at identifying and analysing important aspects in the process of designing a photovoltaic system for a multi-unit housing complex.

The apartment community was built in 1973 and several owners and the property management are interested in installing a photovoltaic system. The apartment complex shows a suboptimal energy efficiency with a level C/D on the energy certificate. Furthermore, the building faces some major maintenance projects within the next 5 -10 years (e.g. roof renewal). The ownership structure of the property is complex and hence it is not easy to reach a consensus on projects of this magnitude. Therefore, the authors set out to explore different options concerning PV dimensioning and possible operating models that could be feasible.

The goal was to maximize the usage of renewable energy sources and to optimize the energy mix of the building. This paper sets out to present basic data concerning the technical status quo of the exemplary building, the stakeholder constellation of all parties involved and discusses different operating models for implementing a photovoltaic system.

## METHOD

The project is based on a variety of research methods, with a particular focus on the specific property in Vienna that was analysed. On one hand, the project group conducted a desktop study on different parameters such as sunlight exposure and PV systems, as well as available operating models and financing options. The collected information was incorporated into a simulation with the software “PV sites”. On the other hand, informal interviews were conducted with owners of the apartment buildings, the property management, energy suppliers and energy experts from FH Technikum Wien.

All the data used for this project was obtained from official reports and plans of this housing complex. Furthermore, the property management company provided additional data upon request. As the plans are still the originals from several years ago, much of the data has yet to be digitized. Furthermore, in order to have enough data for the simulation, estimates had to be applied in some cases.

## PROJECT DATA

The exemplary project consists of 11 buildings, 20 houses, and 106 apartments of different sizes. The complex is situated in the outskirts of Vienna on a hill facing south. The structure consists of a basement, a ground floor, an upper floor and an undeveloped attic. The objects are built in solid construction and erected in 1965. A gas boiler is installed in every apartment and used for heating as well as hot water. The energy consumption of the common area is rather low.

The roofs are made out of tin and have a slope of about 18 degrees according to the original plans of house 13, which were used as an exemplary case.

The roof overhang is about 70cm according to this plan. For the purpose of this project, we assume these data for all houses.

The south-facing roof surface is of particular importance for this project.

As the houses have different sizes, they can be clustered as follows when it comes to the roof surface and their size in general:

- Houses 2, 4, 6, 8, 10, 12, 16, 18, 20: These houses each have about 129m<sup>2</sup> of south facing roof surface. In total this amounts to 1.161m<sup>2</sup>.
- Houses 1,3, 5, 7, 9, 11, 15, 17, 19: These houses each have about 110m<sup>2</sup> of south facing roof surface. In total this amounts to 990m<sup>2</sup>.
- Houses 13, 14: These houses each have about 165m<sup>2</sup> of south facing roof surface. In total this amounts to 330m<sup>2</sup>.

Considering the above-mentioned data, the estimated total south-facing roof surface amounts to 2.481m<sup>2</sup>. Chimneys still need to be considered and hence deducted from this number.

This actual project was initiated, as a new owner wanted to start a conversation about PV System. In the past, many owners have already expressed the wish to tackle this project, but no one followed-up on it. Due to the prevalence of the topic of renewable energy, and the available subsidies, it has been decided that now is the right time to gather information on the topic of PV at this apartment complex. As the ownership structure is rather complex, with many different individual owners and one company who owns approximately 40% of the property, the project was started on a rather informal level with a small task force that collects non-binding information. The conducted project aimed to contribute to the research that the task force is conducting.

The reasons for looking into installing PV systems at this property are manifold. Apart from environmental factors that encourage the use of renewable energy sources, there are also economic factors can serve as an attractive incentive. On average, a private PV system now pays for itself within

10-12 years and generates a return of 3-4% per year over its entire service life. With a good value for money PV system, it is expected to generate good and secure returns on investments for the property. This is made possible by the statutory feed-in tariff and a large number of financing options and sponsoring [3] [4].

While installing PV systems can be very beneficial for a residential apartment complex, there are also challenges that the project at hand has been confronted with. Every project will have its own specific challenges when it comes to realizing a project such as integrating a solar energy system. Several challenges have already been identified in this very preliminary stage of the project. These challenges have been identified by following the process of the actual project.

The obstacles include, but are not limited to the following:

- **Where to start?** In reality, it is still very difficult to determine how to start a project of this proportion and of this complexity. For the apartment complex at hand, the official project started with the development of a task force group to determine the next steps.
- **The technical pre-conditions of the buildings:** The buildings technically need new roofs, and many other updates are also necessary. The financing options are limited; hence the prioritisation of projects is difficult. Furthermore, the entire property heats with gas, which will also need to change in the next 20 years. How this can be implemented, is unclear at the moment.
- **Manage stakeholders:** Everyone wants a saying in this project, even at a very early stage; and the ownership structure is complex. This makes this project increasingly difficult, as many different opinions have to be considered. The challenge in the early stage is to collect information and get first cost estimates, that are non-binding. Identifying all relevant stakeholders is important in order to know, who has interest in and power over the project.
- **Expectation management:** This is very difficult due to the stakeholders involved. The expectations need to be realistic, and everyone needs to be aware, that this project might not be implementable. Hence, the goal of the task force needs, and this project need to be clear: The goal is to gather information on the feasibility of PV systems.
- **Obtain a (non-binding) realistic cost estimation:** To get a cost estimation, external companies need to be contacted. This is not possible according to the property management company, as no costs may be incurred at this stage.

Due to the complexity of the project, a stakeholder analysis was developed based on the present information that was collected through informal interviews. This analysis is considered as preliminary, as the status of the actual project is still in the very early phase of collecting information. As the actual project progresses, additional stakeholders will need to be considered as well.

Table 1 gives an overview of the stakeholders that are involved in the exemplary project at hand.

**Table 1.** Preliminary stakeholder analysis of chosen property

Stakeholder	POWER over Project	INTEREST in Project	Needs, wants, expectations	Strategy
Taskforce for PV System	AA	AAA	Group of people that wants to kick-off this project.	Get the project ahead and coordinate the different members.
Owners, pro project	AA	AA	Want a saying in what is happening, from the very beginning to the very end.	Engage them from beginning; build a strong front against opposition.
Owners, con project	AA	AA	Want a saying in what is happening, from the very beginning to the	Ask for their opinion and feedback at several stages but do not include them for every small

			very end.	decision.
Owners, undecided	AA	AA	Might want a saying in what is happening, but are unsure of their preference. They need more information in order to make a decision.	Provide them with basic information.
Residents (rent)	0	AAA	Easy handling of potential new process; overview of what is happening; sufficient information.	Information campaign/platform, eg via digital tools.
Property management company	AAA	AAA	Want a saying in what is happening. They are very supportive in the process of gathering information.	Engage them from the very beginning and ask them for help.
Company that owns 40% of the property	AAA	A	Cost savings; selling apartments with surplus, with no or limited investments.	Still unclear how to manage them.
Main Energy Provider in Vienna	AA	A	little interest in project, due to complexity in ownership.	Get a cost estimation from them and discuss options.
Working Group for the property	A	AA	Improve the quality of living at the property and represent the residents and owners of the property.	Assistance in gathering data (such as energy consumption)
Other suppliers and technicians	0	AA	Make revenue	Get different non-binding quotes.
City of Vienna	AAA	A	The administration needs projects as best-practices to lead the energy transition.	Contact the right people to get support.
PV Austria	0	0	Provide assistance.	Use their platform for research.

Legend:

AAA – very high interest/power

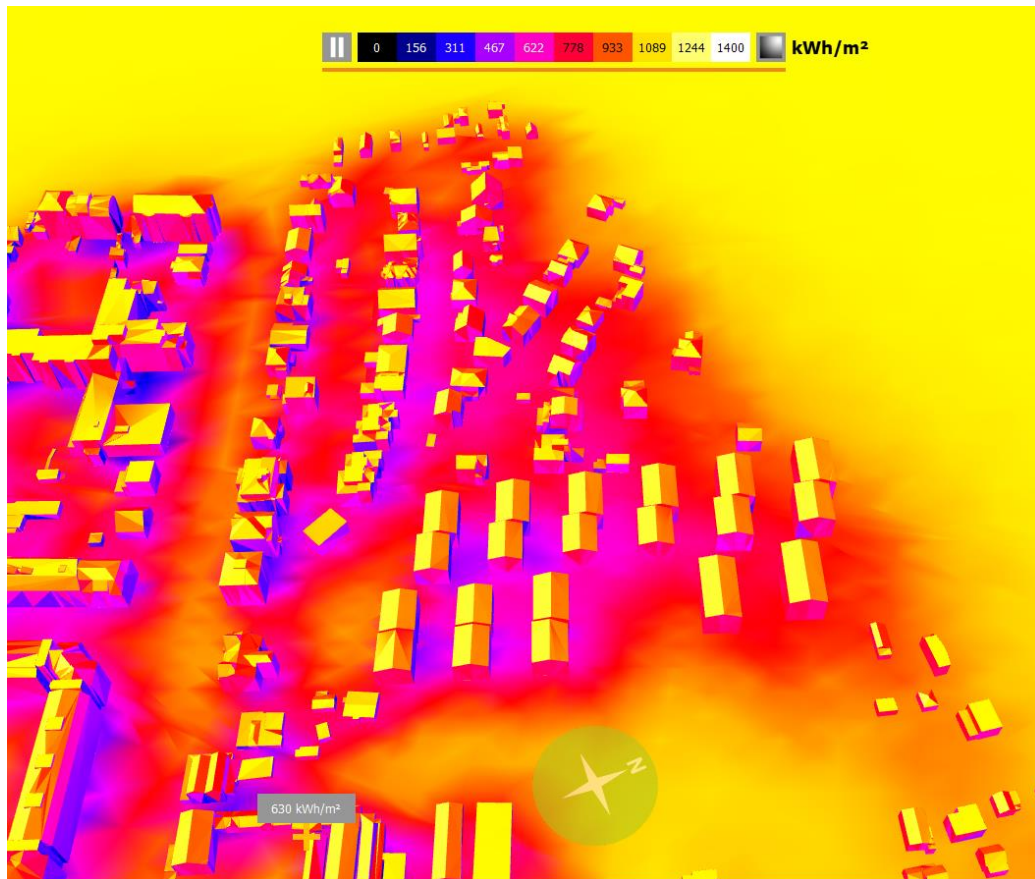
AA – high interest/power

A – limited interest/power

0 – no interest/power

### **Simulation of Photovoltaic**

The property at hand shows ideal irradiation levels, and hence a high potential for PV systems concerning the irradiation.



**Fig.1.** Irradiation on the property from the software “PVsites”

Based on six different simulations that were carried out with the software “PV Sites”, we found that using 435Wp solar panels provided the best ratio of output yield to m<sup>2</sup> of roof area. As for battery storage, this is something that will need to be considered given that most people will be working during the day and given that this report is based on a domestic residence that will mean that without a battery storage system most of the yield would go to waste instead of being used at night when production is at its lowest and consumption at its highest.

The scenario is based on a medium-sized PV system with a nominal capacity of 435Wp that is covering either 50% (scenario 2A) or 100% (scenario 2B) of the roof. This scenario can fit a total of 90 modules (50% roof coverage) and 180 modules (100% roof coverage).

The system capacity of scenario 2A amounts to 39,2 kWp whereas scenario 2B reaches 78,3 kWp. The estimated production for scenario 2A is 42.561,60kWh and for scenario 2B 77.019,20. Scenario 2A shows 0% shadow losses whereas scenario 2B shows 3% of shadow losses. Heat losses are expected between 7,8% (2A) and 8,1% (2B). The array yield in scenario 2A is estimated to be 1.087,1 kWh/kWp compared to 983,6 kWh/kWp in scenario 2B.

### **POSSIBLE OPEERATING MODELS FOR PV SYSTEMS IN AUSTRIA**

If the technical preconditions allow to pursue the project further, then an operating model, which also influences the financing of the project, has to be decided on. There are different operating models available already and additional models are currently available on the market. For the purpose of this study, four models as displayed on the website of PV Austria [10] are described. At this point it is difficult to anticipate which operating model is the most suitable for the project at hand, due to the early stage of the actual project. Nevertheless, it is useful to explore different possibilities at this early stage.

**Model 1: PV system as infrastructure and “free electricity”**

*The property owner invests in the PV system and makes the electricity available to the residents free of charge (comparison: bicycle storage room, laundry room).*

Using energy from the PV system is seen as additional infrastructure that is provided to the residents. The additional benefit for residents is that the monthly operating costs might decrease due to lower electricity costs for the general facilities, such as elevators etc.

Any revenues generated by selling electricity back to the grid belong to the operator of the PV system, so the property owner in this business model. A benefit for the property owner is also that there are hardly any or no organisational effort for drafting contracts with tenants and accounting; furthermore the worth of the property increases [10].

**Model 2: Construction and use by residents' association**

*Residents/property owners invest in the PV system and regulate the operation and shares of use themselves (e.g. founding an association).*

The purpose of the association is the construction, maintenance, servicing and operation of a communal PV system on the building. The association is therefore responsible for and operates the system. The distribution of financing costs, the amount of electricity costs from the PV system and the type of payment flows are defined in the association statutes. The members of the association pay a share of the investment and receive a PV power purchase right in return.

This business model is associated with many organisational and coordinating tasks by the association. Residents who are renting apartments can also contribute to the investment of the PV system (either as an official investment or as a lease payment). They would have two separate electricity bills (for the PV system and from the general grid). For the association, this model bears the risk of uncertainty, as those renting might not want to contribute to the PV system at all. Hence there is economic uncertainty for the association in this model [10].

This model builds on the concept of energy communities, which are described in the final chapter of this paper.

**Model 3: External company builds and leases to residents**

*External company invests and operates the PV system, residents lease a right of use for their own consumption.*

For the residents, the use of the PV system is optional. Either they pay a fixed amount in cents/kWh for the PV electricity actually drawn or a lease e.g. as a fixed amount per period (e.g. year). Each flat is provided with a share of the PV electricity production. The proceeds from the grid feed-in are received by the external company.

The organisation effort and coordination are borne by the external company, as well as the economic uncertainty if residents do not want to participate. The external company needs to rent/lease the roof from the property owner [10].

**Model 4: Energy supplier builds PV system as “full supplier”**

*Electricity supplier builds and operates PV system and supplies PV self-consumption electricity and grid electricity to residents.*

In this model, the PV system operator is also the supplier of the remaining grid electricity to the customer. Accordingly, this model is only suitable for energy suppliers. The resident can therefore only obtain the PV electricity if he or she is also an electricity customer of the system operator/energy supplier. On the part of the energy supplier, this model also serves as a means of customer retention or to acquire new customers. Also in this case, the external company needs to rent/lease the roof from the property owner [10].

## CONCLUSION

In conclusion, this paper has aimed to give overview possible operating models of a PV system at an exemplary Viennese residential housing complex. While the project has a lot of potential when it comes to the possible yield from solar panels, there are several obstacles that need to be analyzed in detail before the project can be potentially realized. The next step for the taskforce of the actual project is to obtain initial cost estimations and a technical status-quo of the property. These aspects exceed the scope of this paper and could therefore not be analyzed in detail. This paper showed potential of a PV system when it comes to the irradiation at the property and gave an overview of the involved stakeholders. The dynamics of the stakeholders are expected to change if the project should be realized. Nevertheless, the stakeholder analysis that was developed in this project report already gives a general overview of the key stakeholders.

In general, the research has demonstrated that there is potential in the realization of the project when it comes to the yield that can be generated by PV systems, also in relation to the estimated energy consumption of the residents. The challenge is to find the right model and the legal opportunities to share the energy with the other owners and renters. The concept of energy communities could be a solution to address this issue and hence future research should explore this concept in the context of urban areas and existing residential building complexes.

## OUTLOOK: ENERGY COMMUNITIES

The energy transition has opened the gateway for many new business models that also have the power to transform the traditional consumer of energy to a prosumer. Traditionally, prosumers were associated with individuals or businesses. Recently, the term has been extended to communities; these are citizen-led renewable energy projects that include, but are not limited to individual households, businesses, neighborhoods, and commercial sites. Prosumers generate renewable energy and self-consume part of that energy themselves. However, producing energy and selling it is not their main business. With falling costs, on-site renewables are becoming increasingly more popular on a decentral level. Simultaneously, energy systems are getting smarter and hence accounting for smaller amounts of energy that are produced and sold is getting easier.

The introduction of the Clean Energy Package (CEP) in Europe is an important step when it comes to shaping the energy transition. This package enables all Europeans to become individual or collective prosumers. Two different types of collective prosumers can be distinguished: Renewable Energy Communities (RECs) and Citizen Energy Communities (CECs). Within these communities, prosumers are empowered to produce, use, sell and trade energy among their community [11].

The European Union has specified the following primary focus of energy communities:

*“Community energy initiatives focus primarily on providing affordable energy of a specific kind, such as renewable energy, for their members or shareholders rather than on prioritizing profit-making like a traditional electricity undertaking.”* [11].

For the project at hand, establishing an energy community could be an interesting option. Hence, further research should be conducted on the economic feasibility of establishing an energy community at existing residential buildings in urban areas, such as Vienna.

## REFERENCES

- [1] Wien Energie (2020): Vienna amends building regulations; Accessed on June 12<sup>th</sup> 2021 at <https://positionen.wienenergie.at/blog/wiener-bauordnungsnovelle/>
- [2] Statistik Austria (2013): Buildings 1971 until 2011 divided by criteria; Accessed on June 12<sup>th</sup> 2021 at [https://www.statistik.at/web\\_de/statistiken/menschen\\_und\\_gesellschaft/wohnen/wohnungs\\_und\\_gebaeudebestand/Gebaeude/074079.html](https://www.statistik.at/web_de/statistiken/menschen_und_gesellschaft/wohnen/wohnungs_und_gebaeudebestand/Gebaeude/074079.html)
- [3] Energiemagazin.at (2021): [Photovoltaik – financing and subsidies in Austria](https://www.energiemagazin.at/photovoltaik-finanzierung-und-foerderungen-in-); Accessed on June 13<sup>th</sup> 2021 at <https://www.energiemagazin.at/photovoltaik-finanzierung-und-foerderungen-in->

- [oesterreich/#:~:text=Pro%20Jahr%20steht%20der%20Republik,eingerichteten%20Klima%2D%20und%20Energiefonds%20entnommen.&text=Die%20OeMAG%20ist%20einer%20der%20wichtigsten%20F%C3%B6rderer%20von%20erneuerbaren%20Energien](#)
- [4] PV Austria (2021): Austrian Subsidies; Accessed on June 13<sup>th</sup> 2021 at <https://pvaustria.at/forderungen/>
- [5] Stadt Wien (2021): Wie Umweltgut. *Solar Potential Map*; Accessed on June 11<sup>th</sup> 2021 at <https://www.wien.gv.at/umweltgut/public/grafik.aspx?ThemePage=9>
- [6] Sunvalleysolar.com (2019): Financial benefits of solar system; Accessed on June 13<sup>th</sup> 2021 at <https://www.sunvalleysolar.com/blog/what-are-financial-benefits-solar-power>
- [7] Erneuerbare Energien (2015): PV system increase property value; Accessed on June 13<sup>th</sup> 2021 at <https://www.erneuerbareenergien.de/archiv/solaranlage-steigert-wert-des-gebaeudes-150-436-84749.html>
- [8] The ecoexperts (2020): A Guide to Solar Inverters; Accessed on June 11<sup>th</sup> 2021 at <https://www.theecoexperts.co.uk/solar-panels/inverter-costs>
- [9] Greenmatch (2021): How Much Does a Solar Battery Storage System Cost; Accessed on June 10<sup>th</sup> 2021 at <https://www.greenmatch.co.uk/blog/2018/07/solar-battery-storage-system-cost>
- [10] PV Austria (2021): Umsetzungsvarianten; Accessed on May 24<sup>th</sup> 2021 at <http://pv-gemeinschaft.at/umsetzungsvarianten/>.
- [11] The European Parliament and the Council of the European Union, Directive (EU) 2019/944: Common rules for the internal market for electricity and amending Directive 2012/27/EU. p. 43. [Online]. Accessed on July 1<sup>st</sup> 2021 at: <https://eur-lex.europa.eu/eli/dir/2019/944/oj>



## COOLING TECHNOLOGIES OF DATA CENTERS

Stanko P. Stankov<sup>1</sup>

<sup>1</sup>University of Niš, Faculty of Electronic Engineering, Department of Automatic Control,  
Aleksandra Medvedeva 14, 18000 Niš, Serbia  
email: stanko.stankov@elfak.ni.ac.rs

**Abstract:** The installation of more and more powerful processors and the constant striving to reduce the size of the hardware architecture have conditioned the cooling of data centers to become a very complex task. Modern servers generate ten times more heat energy than systems built just a decade ago. The consequence of the installation of powerful servers leads to the formation of the so-called hot zones with high heat load. Efficient cooling of these zones in traditional way is often impossible. In order to ensure the reliable operation of modern data centers, in which the infrastructure is installed with high density, it is necessary to apply new strategies and technologies to ensure adequate cooling of the equipment. Modern server racks often consume more than 5 kW of electrical energy, with a constant tendency to increase consumption. Practice shows that conventional cooling systems are already inefficient for these powers. A quality cooling solution for data centers will significantly contribute to the overall energy efficiency.

**Key words:** servers, rack, cooling, aisles, energy efficiency

### INTRODUCTION

Data centers are sets of servers and other computer equipment on which numerous services required by a large number of users are carried out. Modern companies have a need for services, which must be fast, reliable and available at any moment. This has imposed the need to develop data centers in a growing number of companies [1-3]. Virtual servers reduced the need for a large number of physical servers, which at the same time allowed more services to run on the same servers through the virtualization process. It encouraged the development of information systems in small and medium enterprises and added momentum to their improvement in the enterprise segment [3], [4]. The development of data centers requires the environment in which the servers are installed to be improved in order to ensure stable, reliable and uninterrupted operation of all servers in the data center in order to provide users with constant access to data and mechanisms for their processing. These requirements can be met by keeping track of changes in technology, safety and other components of the environment such as climate conditions, communications and rules of conduct. Therefore, it is necessary to transform the data centers step by step until the final consolidation [5].

Data center should provide:

- reliable internet, provided with several internet operators;
- safe power supply of devices and equipment;
- generators that will enable normal mode in case of mains supply failure;
- room for air monitoring system (temperature, humidity);
- reliable air conditioning system to maintain the required temperature and humidity in the premises;
- appropriate fire protection system;
- technical support, in order to take timely and adequate measures in case of failure of a particular device;
- physical security of the facility;
- limited access to the premises [1], [6].

The role of cooling systems in computer centers consists of maintaining appropriate conditions that are optimal for the exploitation of computer resources (Information technology equipment - ITE). These systems must operate reliably and continuously. It is recommended that the room temperature is in the range of 21 °C - 24 °C with a deviation of  $\pm 3$  °C, and humidity of 50 % with a deviation of  $\pm 10$  %. For the security and functionality of the data center, it is necessary to provide: authorized persons with access to the center, monitoring of the data center by video surveillance and access control, supervision of the operation of complete equipment, installation of fire protect and alarm systems. Maintaining the optimal temperature is extremely important for the smooth operation of computer machines and it is a priority in data centers in order to provide quality and reliable services to

customers. The energy required to cool data centers during operation can be quite high if the necessary measures to install a reliable and energy efficient cooling system are not taken [7]. In addition to cooling, power supply is crucial for data centers. Power outages can cause major problems, because even after the power is restored, it is not certain that all data has been saved due to improper shutdown of the server, nor that all services are functional. Servers need some time to boot operating systems, whereby power consumption reaches peaks, so in case of inadequate sizing of the electrical installation, the data center may crash. The organization of power supply of the data center is shown in Fig. 1. [1], [7].

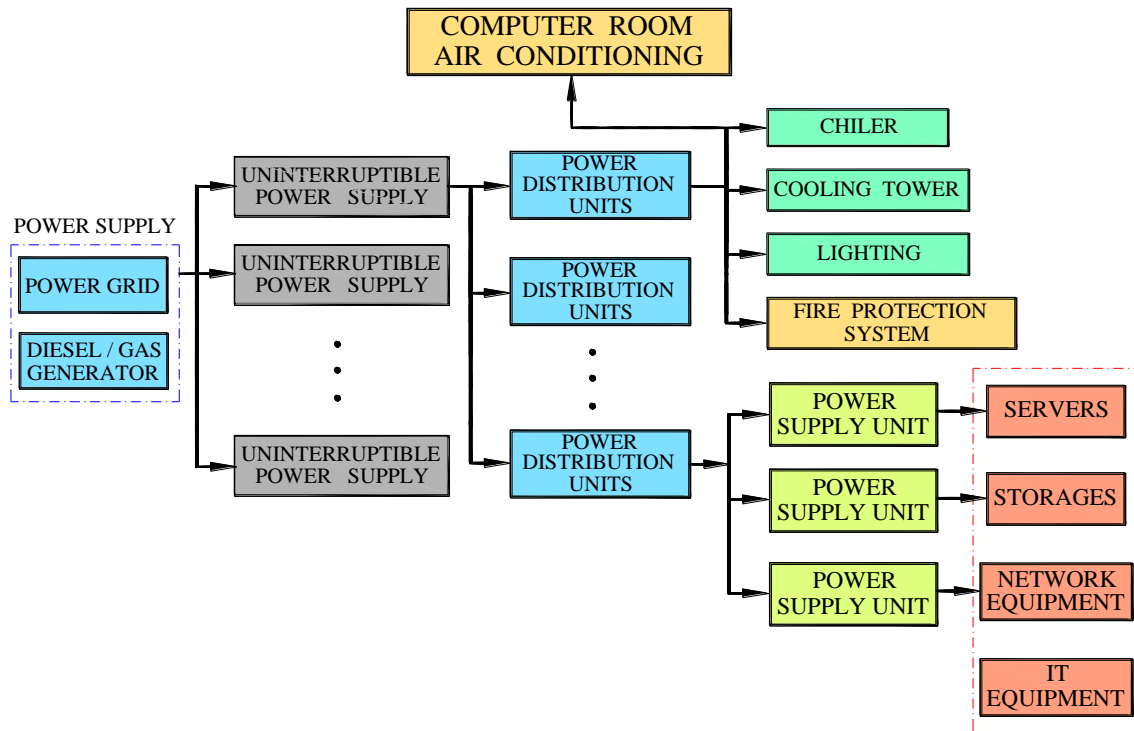


Fig. 1. Power supply of the data center

The installation of powerful servers in computer centers has of creating the so-called as the consequence hot spots - zones with a higher thermal load compared to zones with older generation equipment. Efficient cooling of such zones is practically impossible to achieve by applying conservative techniques. Reliable operation of modern data processing centers, which are characterized by a high density of embedded computer resources, uses a new strategy and technology that can provide adequate cooling of equipment. Efficient cooling is ensured by installing cooling systems to the heat source. The use of technological fluids that absorb heat during the change of its physical state can also achieve cooling efficiency. When the refrigerant is in a gaseous state, the risk of liquid leakage is eliminated, which can lead to equipment failure in the data center [8]. In order to ensure adequate heat spreading, racks with servers are usually placed at a certain distance from each other, which practically limits the number of racks per unit area and increases the maintenance costs of the entire system. For example, in a room of 1000 m<sup>2</sup>, with adequate maintenance, no more than 50 rack cabinets with a heat load of 10 kW per rack can be installed, provided that a raised floor is used. With additional cooling, 386 racks can function safely and efficiently on that surface, which is practically eight times more equipment on the same surface. Data centers generate heat with less humidity compared to ordinary rooms where people live or the outside air enters, which is why such facilities use air conditioners that consume less energy when absorbing moisture from the air, and more to absorb heat, compared with air conditioners intended for households. Such air conditioners enable additional humidification of the air, which maintains the relative humidity in the room to the allowed value of 50 % [9]. Optimization of the spatial arrangement of server racks that enables the formation of alternating hot and cold aisles - Fig. 2. can increase the cooling efficiency with a raised floor system.

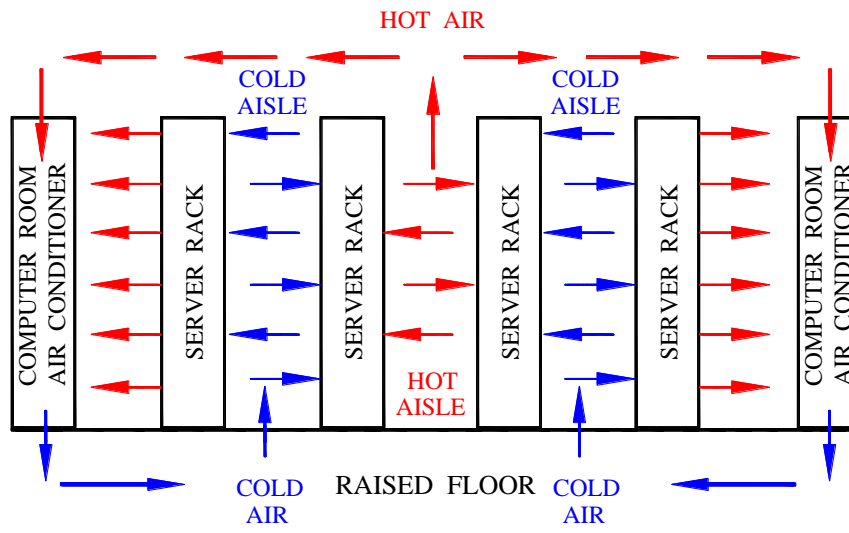


Fig. 2. Circulation with raised floor and hot-cold aisles

Hot and cold aisles can be lined up face to face, with a cold stream of air passing past the cold aisles and entering the server cabinets to exit through the back of the hot aisle. There is also the possibility of partitioning so as not to mix cold and warm air. A partition in combination with a double floor can be an efficient way of cooling. Contrary to this, the insulation of warm aisles is done by means of a system on the back of the server cabinets from where warm air comes out. In this way, certain parts of the room become a warm aisle. These systems can be directly connected to the air duct to the air chamber in the computer room and can work with a pre-installed water economizer [10].

## ENERGY EFFICIENCY

In the era of IoT (Internet of Things) technology, trends in the use of cloud infrastructure, remote services, training and remote workplaces are becoming increasingly popular, and the Covid 19 pandemic has contributed to this being used in less developed countries as well. As already mentioned, data centers around the world use more than 4 % of the world's total electrical energy consumption. Forecasts say that the consumption will double every four years. Electrical energy is used in data centers for equipment operation (50 %) and for cooling (30 %). It is obvious that in the current configuration of data centers, electrical energy consumption will increase enormously in the future. There is a need to find environmentally friendly solutions for cooling computer resources. It is believed that the free cooling method will save 80 % on cooling data centers. Energy efficiency is the main focus when solving the problem of cooling data centers. Having in mind the profitability of the facility, it is recommended to choose modern efficient technologies regardless of the current high price, which pays off in the long run. An efficient solution in every sense of the data centers will significantly contribute to the overall energy efficiency [1], [8]. ServeCool combines three different cooling methods. Free cooling takes place through the outside air that enters the room indirectly, passing first through a plastic exchanger. Thanks to efficient recuperation, the air is cooled and led into the interior of the room, without creating dust and retaining moisture in sensitive server blocks. When cooling based on recuperation is not enough, an adiabatic cooling system is automatically switched on - an efficient way of using renewable resources. These two cooling modes - recuperation with a plastic exchanger and adiabatic cooling cover 97 % of the operating time. In the remaining time of 3 %, the mechanical system (chiller) is switched on. This concept enables maximum reliability and minimum energy consumption [11]. This concept provides maximum reliability and minimum energy consumption compared to conventional systems that use a combination of passive (50 %) and mechanical cooling in the amount of 25 %.

## COOLING TECHNIQUES

During the decades of development of the IT system for cooling computer rooms and data centers, double floors were most commonly used, through which cold air is delivered. There is cold air from the computer room air conditioner (CRAC) or air chamber (Computer room air handler - CRAH). The use of perforated panel floors allows cold air to flow into the server room. By passing through the server, the cold air is heated and returned to the air chamber to be cooled again. The return pipe temperature is often used as a control point to which the cooling system is controlled. During a number of years of operation of data centers, the most common choice of cooling is the use of a double perforated floor, which is still a common case today. The basis of this method of cooling with a relatively small amount of air-conditioned air is mixing with the air in the room, which achieves the desired temperature. Although the comfort and efficiency of these systems is high if the server equipment is not dense, it can hardly be said that this relatively simple method is obsolete. Many companies base their data center cooling system in this way. However, more and more people are resorting to new and more efficient technologies in terms of cooling data centers. One of the popular ways to cool data centers today is to use cold and hot corridors and close empty spaces in server racks with special panels. These panels prevent the return of warm air that would enter the front of the server through the opening. In order to facilitate air exchange, it is necessary to remove all elements that would block the suction and exhaust openings of computer equipment. Besides, weakened airflow increases energy consumption, due to more intensive fan operation. If there are doors in the racks, they should be perforated and kept at least 65% open. Solid doors or those made of glass, plexiglass or other material inevitably hinder the flow of air, and thus the cooling process.

## HEAT DRAINAGE

IT equipment is powered by electricity, which releases heat, which without proper ventilation leads to a series of failures, failures and data loss. The cooling process itself, which is necessary in data centers, causes certain problems due to the additional energy consumed by the cooling infrastructure. There are generally two ways to dissipate heat in data centers: by air or by coolant (usually water or refrigerant). Air cooling is simpler as there is no danger to install Information technology equipment – ITE. The favorable circumstance also lies in the distribution of hot and cold air, bearing in mind that warm air goes upwards as easier. This feature is used by a large number of cooling systems. However, this is not a particularly effective solution, as hot and cold air are mixed, which reduces efficiency [1], [10]. On the other hand, the coolant leads directly to the server cabinets and is precisely directed to the hot spots, while not cooling the entire space. However, possible leaks in this system can be a great danger for IT equipment. One of the solutions for heat dissipation in data centers is the installation of heat exchangers in the server cabinets themselves. Exchangers extract heat from the server and eliminate it with liquid. Such cooling devices are installed in the immediate vicinity of the server. After taking heat from the server, it is usually discharged into the atmosphere, water tanks or the ground. There are several ways to dissipate heat:

- CRAH (A computer room air handler) - plants with water-cooled chillers and cooling towers,
- CRAH - air-cooled chiller plants,
- air conditioning split systems for rooms with computers,
- CRAC (Computer Room Air Conditioner) - plants with cooling towers,
- working fluids and cooling towers,
- air economizer,
- air economizer with direct cooling by evaporation,
- indirect cooling with evaporation.

## MEGA DATA CENTERS IN THE WORLD

Huge funds in the construction of giant data centers are invested by Google, Amazon, Microsoft and IBM. The largest number of these centers is installed in the USA (44 %), in China 8 %, 6 % are located in Japan and GB. In countries such as Australia, Germany, Singapore, Canada, India and Brazil, the percentage ranges from 3 to 5. Based on this, it is evident that the USA is the world market

leader in data centers and has a dominant role in cloud and internet technologies. The consulting firm Arizton predicts that the global market of data centers will reach 174 billion \$ by 2023. IoT technologies are constantly increasing the demand for data centers, with data becoming increasingly valuable. In this regard, a sustainable, efficient, adaptable and resilient data center infrastructure is needed if owners want to increase of profit. The intensive increase in investments is evidenced by the fact that in the first half of 2018. The operators of the largest data centers in the world, such as Google, Microsoft, Amazon, Apple and Facebook, have invested over \$ 53 billion in the development of their infrastructures, compared to the same period in 2017. A significant part of investments in the world relates to the construction and expansion of large data centers. There are over 420 such centers installed in the world, most of which are located in the USA. These are Synergy Research analyzes based on information on the size of investments in data centers of the world's 20 largest companies providing cloud and online services, including Infrastructure as a service (IaaS), Platform-as-a-Service (PaaS) and Software as a service (SaaS), search engine operators, social networks and online magazines [12]. Alibaba, Baidu, IBM, JD.com, NTT, Oracle, SAP and Tencent are among the companies that invest the most in data center development. It is interesting that these companies are not in the top 5. Capital investments in mega data centers are the biggest indicator of intensive growth and development of cloud and digital technologies, as well as on-line lifestyle. The costs of mega data center operators reach enormous values and continue to grow. They are extremely increasing their competitive advantages, with "small players" in this area no longer having a chance to race. This tendency is obvious especially in the cloud computing market where giant data centers are simply destroying competition [13]. Schneider Electric, one of the world leaders in energy management, has efficient solutions for data centers. InRow RC precision air conditioning systems significantly reduce energy consumption. In the high inlet temperature model, which is designed for optimal heat dissipation, higher cooling fluid temperatures and higher ambient air temperature increase cooling efficiency, whereby the number of hours of free cooling increases [14]. As part of Schneider Electric's InfraStruXure solution, the InRow RC reduces the distance between the heat source and the heat dissipation, thus reducing the mixing of hot and cold air currents. Variable speed fans reduce power consumption during peak reduction times or when the data center is partially loaded. Schneider Electric has also reached a high standard in UPS technology - for example the Galaxy VM, a three-phase system for uninterruptible power supply, peak reduction time or when the data center is partially loaded. Galaxy VM, is a key component in an integrated power control solution. This compact design device is easy to install, takes up little space in data centers and saves 90% of energy through the intelligent EConversion mode. System corrects input harmonics while combining dual online conversion with improved environmental performance and provides optimal efficiency for critical loads of various equipment such as those in data centers. Operators in data centers of demanding industrial and other facilities are constantly looking for a balance between the need for high energy efficiency and maximum access and uninterrupted operation of equipment. For these reasons, the Galaxy VM is the solution to these requirements [14].

## **COOLING OF DATA CENTERS IN THE FUTURE**

Servers in data centers generate a large amount of heat, while air cooling is very expensive. For example Microsoft spends over \$ 15 billion a year building and maintaining 100 data centers. This is also the main reason why this company is trying to install its cloud data centers in waterproof containers on the ocean floor. Theoretically, ocean water should cool servers, and electricity would be generated by waves. The idea of building underwater data centers was spurred by energy savings for cooling computer resources. Data centers are large consumers of electricity (nowadays over 430 TW), with 15 to 20 % spent on computer cooling (according to CNET - Computer Network). Theoretically, the cold waters of the North Sea can contribute to significant savings. Experiments to date have shown that heat from the housing of data centers can be efficiently dissipated in the ocean. In addition, these data centers are unmanned. Air with oxygen and water vapor is extracted from the server rooms, which solves the problem of corrosion [15]. It is natural that in such conditions, equipment that is defective cannot be replaced. However, the creators of these interesting experiments are of the opinion that in such conditions of exploitation, the probability of failures and failures of computer equipment is significantly reduced [16]. Microsoft has already experimented in this regard by installing a 2.4 m

diameter steel capsule (Project Natick - Fig. 3) in the North Sea, which has been under water for 105 days. During testing, this module processed Azure's cloud service commercial data. Microsoft continues research with several times larger modules compared to the tested prototype [17], [18]. Microsoft conducted the first experiment with an underwater data center during 2015.



**Fig. 3.** Project Natick ready for deployment [15]

Then a container called Leona Philpot was sunk for 5 months. Microsoft believes that it is expedient to install data centers on the seabed, since over 90 % of these centers are now located near large cities - London, Frankfurt and other major global centers for the flow and exchange of data. In this regard, environmental associations oppose the idea, believing that the installation of underwater data centers will lead to an increase in the temperature of the world sea. But even the most approximate calculations show that the increase will be insignificant - no more than a thousandth of a degree Celsius [18], [19]. During 2018, Microsoft has installed a data center with 864 servers at the bottom of the Scottish Sea, at a depth of 36 m. This company has the idea to set up similar data centers near the shores of certain areas where these centers are needed. Practice shows that the failures of data centers installed on the ocean floor amount to only one eighth of failures in data centers installed on land. The company's next step in this direction is to find a way to extract data centers from the ocean floor for troubleshooting.

### **SUPERVISION AND CONTROL OF DATA CENTERS**

The IT infrastructure is characterized by rapid changes and constant adaptation to customer needs. Cloud and as a Service technologies are very common today. Emergence of phenomena such as Big Data, Machine Learning, Artificial Intelligence, Data Mining and etc. which are related to data, has caused an increase in all segments of computer infrastructure. The fact that 90 % of all existing data has been generated in the last two years testifies to the constant increase in the amount of data. In order for the IT sector to cope with such a drastic increase in the amount of data, it is necessary, in addition to capacity flexibility, fast computer nodes and faster data transfer within the data center, to reduce downtime or interruptions to a minimum. This can be ensured by monitoring and control of the entire infrastructure [1]. In 2018, the Uptime Institute conducted research on the functionality of data centers. It was concluded that in the period 2015 - 2018, 48 respondents had work interruptions given at least once. According to Gartner's research, a one-minute data center outage costs an average of \$ 5,600. Due to the interruption of the data center, negative effects occur, such as loss of sales, damage to the reputation of companies, reduction of productivity, loss of data and etc. Overcoming the

aforementioned problems can be achieved by applying a central system of supervision and management of the data center, which reduces the probability of failure of data center components. Data Center Infrastructure Management (DCIM) is software that monitors the complete computer and other data center infrastructure, through a centralized control screen on which all vital components of the system can be viewed in detail. Google has promoted real-time data center monitoring and management systems using artificial intelligence. They came to the conclusion that cooling is carried out 75 % more than the required value. According to data center knowledge.com data, center cooling is designed according to the instructions of risk management organizations [20]. However, there are more and more solutions that turn to the precise operational control of data centers air conditioning, permanent monitoring of temperature and energy consumption. Based on that, one of the world's companies in the field of cybersecurity managed to increase the average temperature of server rooms by 3 °C, which leads to energy savings for cooling on an annual level of 25 % [21 - 23].

## CONCLUSION

It is obvious that cooling data centers requires a very complex choice and a comprehensive solution. There are a number of techniques based on air or water cooling, which use different sources, while working on optimizing the interior of the room, controlling energy consumption etc. The physical and geographical features of the location where the data center is located are considered, the existing technologies, tendencies and possibilities for optimal energy use, return on investment – ROI, power usage effectiveness (PUE), total cost of ownership - TCO. It is concluded that high-class equipment is not enough for the overall efficiency of data centers. It is necessary to have a broader view of the problem, anticipate further development and expansion of the data center, adoption of the concept by experts, design and correct execution, as well as proper maintenance of installed capacities. The efficiency of a single data center simply cannot be bought.

## REFERENCES

- [1] Stankov, S., Perić, S.: Konfiguracija sistema za upravljanje zgradama, 41 međunarodni Kongres KGH, Zbornik radova (str. 100 - 112), Beograd, decembar 2010.
- [2] HVAC Design and Cooling for data Center Efficiency Spiral-Bound – International Edition, Publisher: Strategic Media Asia Limited; 2nd edition, January 1, 2019.
- [3] Stankov, S., Mitić, D., Ičić, Z.: Supervisory and Control of HVAC Systems, journal „Facta Universitatis”, Series: Automatic control and Robotics, vol. 9, No 1 (pp 151 - 160), 2010.
- [4] Bhatia, A.: HVAC Cooling Systems for Data Centers, Continuing Education and Development, Inc. 22 Stonewall Court Woodcliff Lake, 2020.  
<https://www.cedengineering.com/userfiles/HVAC%20Cooling%20Systems%20for%20Data%20Centers%20R1.pdf>
- [5] Orsaria, A., Jang, M.: RHCSA/RHCE Red Hat Linux Certification Practice Exams with Virtual Machines, Second Edition, Jan 24, 2020.
- [6] Shehabi, A., Smith, S. J., Horner, N., Azevedo, I., Brown, R., Koomey, J., Masanet, E., Sartor, D., Herrlin, M., Lintner, W.: United States Data Center Energy Usage Report. Lawrence Berkeley National Laboratory, Berkeley, California, 2016.
- [7] Capozzolia, A., Primiceri, G.: Cooling systems in data centers: state of art and emerging technologies, 7th International Conference on Sustainability in Energy and Buildings, Torino, Italy, 2015.
- [8] Manganelli, M., Soldati, A., Martirano, L., Ramakrishna, S.: Strategies for Improving the Sustainability of Data Centers via Energy Mix, Energy Conservation, and Circular Energy, Sustainability 2021.
- [9] Google Data Centers. Efficiency: How we do it.  
<https://www.google.com/about/datacenters/efficiency/internal/>
- [10] Stankov, S., Mitić, D., Ičić, Z.: Control of HVAC Systems, X Triennial international SAUM Conference on Systems, Automatic Control and Measurements, pp 152 - 157, Niš, Serbia, Niš, november 10<sup>th</sup> ÷ 12<sup>th</sup>, 2010.
- [11] <https://www.google.com/search?client=firefox-b-d&q=ServeCool>

- [12] <https://www.srgresearch.com/>
- [13] <https://www.srgresearch.com/research/cloud-infrastructure-services-deep-dive>
- [14] Niemann, J., Bean, J., Avelar, V.: Economizer Modes of Data Center Cooling Systems, Revision 0, Schneider Electric white paper library produced by Schneider Electric's Data Center Science Center, 2011.  
[https://download.schneider-electric.com/files?p\\_Doc\\_Ref=SPD\\_JNIN-7RMNRX\\_EN](https://download.schneider-electric.com/files?p_Doc_Ref=SPD_JNIN-7RMNRX_EN)
- [15] Microsofts Underwater Server Experiment Resurfaces After Two Years  
<https://www.theverge.com/2020/9/14/21436746/microsoft-project-natick-data-center-server-underwater-cooling-reliability>
- [16] Hume, D.: Underwater Data Centers, October 24, 2017.  
<https://theliquidgrid.com/2017/10/24/underwater-data-centers/>
- [17] Project Natick: Microsofts Underwater Voyage of Discovery  
<https://www.datacenterdynamics.com/en/analysis/project-natick-microsofts-underwater-voyage-discovery/>
- [18] Copeland, M., Soh, J., Puca, A., Manning, M., Gollob, D.: Microsoft Azure: Planning, Deploying, and Managing Your Data Center in the Cloud, 1st Edition, September 30, 2015.
- [19] Microsoft Pulls Underwater Data Center Back to the Surface to Assess Benefits of Deep-Sea Cloud, 2020.  
<https://www.geekwire.com/2020/microsoft-pulls-underwater-data-center-back-surface-assess-benefits-deep-sea-cloud/>
- [20] China Launches Underwater Data Center  
<https://www.datacenterdynamics.com/en/news/china-launches-underwater-data-center/>
- [21] <https://www.datacenterknowledge.com/>
- [22] Strong, L., Huttemann, R.: Managing Airflow at the Room Level, Data Center Containment best Practices that don't Your Budget – part 3, May 26, 2020.  
<https://www.missioncriticalmagazine.com/articles/92991-managing-airflow-at-the-room-level>
- [23] Dai, J., Ohadi, M., M., Diganta, D., Pecht, G., M.: Optimum Cooling of Data Centers: Application of Risk Assessment and Mitigation Techniques, Springer, 2014.



## INFLUENCE OF PANEL LOCATION AND ORIENTATION ON EFFICIENCY OF PHOTOVOLTAIC POWER PLANT

Luka Đorđević<sup>1</sup>, Jasmina Pekez<sup>1</sup>, Borivoj Novaković<sup>1</sup>, Mića Đurđev<sup>1</sup>,  
Ivan Palinkaš<sup>1</sup>, Dragana Milosavljev<sup>1</sup>, Branko Markoski<sup>1</sup>

<sup>1</sup>University of Novi Sad, Technical Faculty "Mihajlo Pupin", Zrenjanin, Serbia  
e-mail: [luka.djordjevic@tfzr.rs](mailto:luka.djordjevic@tfzr.rs)

**Abstract:** The exponential growth of solar power plants and the utilization of this renewable energy source in all developed countries of the world is evident. The Republic of Serbia, as a country that is an importer of electricity, must turn to the use of alternative and renewable energy sources to a much greater extent, not only because of the independence of our electricity supply system but also because of the reduction of environmental pollution. This paper presents a simulation of installing a solar power plant on the average house of a household in Serbia (location: Zrenjanin municipality) and the influence of the orientation of the panel installation on the amount of electricity obtained. The simulation was done using a combined use of PV GIS and K2 Base software. This paper is an indicator of the possibility of electricity production of a household and its contribution to the independence of the supply system of the Republic of Serbia from imported energy sources. A brief theoretical economic analysis of the cost-effectiveness of setting up a solar power plant in relation to the average household consumption is given.

**Key words:** solar energy, solar power plant, renewable energy, PV GIS, K2 Base

### INTRODUCTION

We are witnessing exponential growth in the use of renewable energy sources in the world. Increasing the number of inhabitants on the planet and economic growth and industry requires higher energy consumption. Conventional sources (coal, fossil fuels ...) still have the upper hand in obtaining energy. Deteriorating environmental conditions, negative climate change, and many other negative factors are clear signs that we must turn to the use of alternative energy sources and reduce the negative impact of energy production on the environment.

Of the many alternative sources, solar energy potential is the largest and the most widespread on Earth. Moreover, if not of the same intensity, solar radiation is available in every part of the planet, implying that it can be used globally [1, 2].

In one hour, the Earth is irradiated with an amount of energy sufficient to meet the total annual energy consumption consumed in the world [3]. The application of solar energy is environmentally friendly, does not pollute the environment, and does not create dependence on imports as an energy source. The Republic of Serbia receives about 40% more solar radiation than the average of other European countries, and it is around 1400 kWh / m<sup>2</sup> per year [4]. The progress in the application of solar energy in the last decade is also reflected in the increasing production of solar energy collection equipment, which led to an average drop in the price of equipment in the world of 82% in the period from 2009 to 2019. In the European market, the price of equipment has dropped by about 90%. At the same time, the conversion of solar radiation into electricity of average equipment in the same period increased from 14% to 18%, which indicates a constant improvement in this field [5].

### MATERIALS AND METHODS

For the needs of this paper and the realization of the potential analysis, the software PV GIS and K2 Base were used. PV GIS software was used to obtain data on the possibility of exploiting the potential of solar radiation. Based on the given data of location, slope, orientation, and nominal power of the panel, data on the average annual radiation and the maximum amount of electricity that can be obtained were obtained. K2 Base software was used to obtain the possibility of structural installation of a photovoltaic power plant. Based on the given input data, the output data on the statics of the roof on which the structure is located, the power plant's nominal power, and the cost price of the structure required for the installation of the same are obtained.

## PV GIS - photovoltaic geographical information system

The Photovoltaic Geographic Information System, abbreviated PV GIS, is free online software developed by the European Commission and is used as a tool to assess the performance of solar PV systems and easily assess the potential for PV electricity generation for selected locations in Europe. The goal of this software is to increase the use of renewable energy in the European Union. Simulations done with this software, as well as comparative analyzes of real results and results obtained by simulations in PV GIS, have been processed in many papers. Using PV GIS software, the following output data are obtained: average daily, monthly, and annual solar radiation values recorded on a square meter of horizontal surface or surface inclined at a certain angle in relation to the horizontal surface [6-9].

To obtain the output data, the software uses data on solar radiation obtained by measuring meteorological geostationary satellites and stations on the ground in the last twelve years [10]. The appearance of the software is shown in Figure 1.

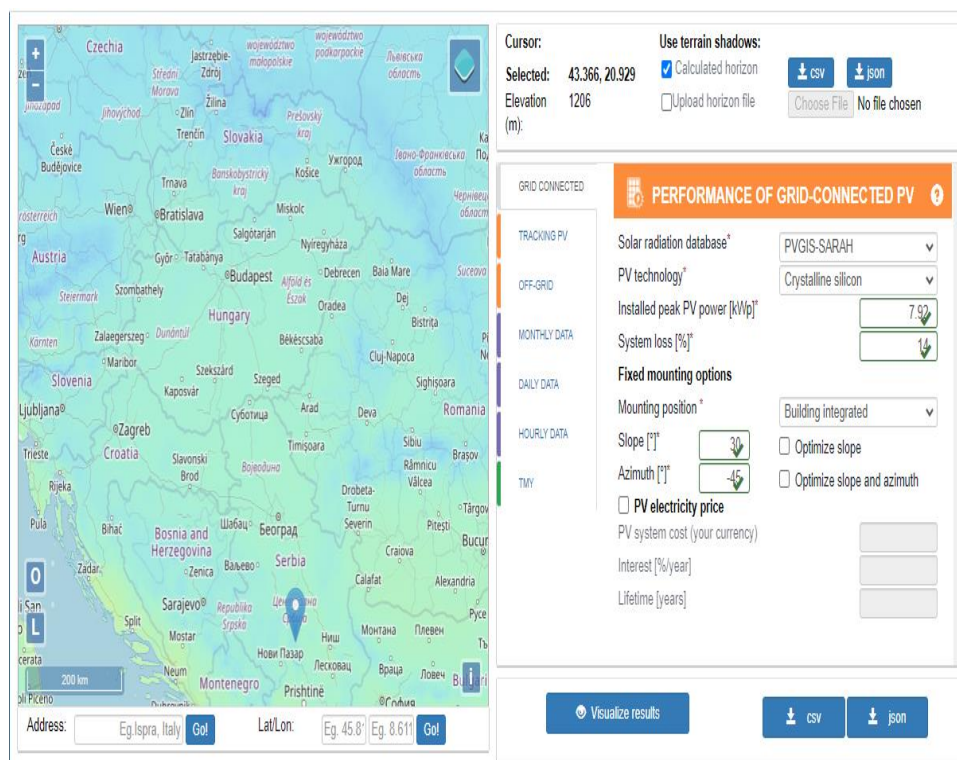


Fig. 1. PV GIS software interface

## K2 BASE

K2 Base is a free online calculation and planning software used to dimension the construction of photovoltaic systems [11]. It was made by the German company K2 Systems, which manufactures structures for the installation of photovoltaic systems. K2 Base software requires a large number of input data entries (from the system installation location, roof type, orientation, obstacle leading to the shadow on the panel, type of installed panels, etc.). As an output, it provides an optimized view of the structural installation of the system with the possibility of a correction in order to make the most of the space provided for the installation of the photovoltaic system. The software integrates a large database of manufacturers and types of solar panels with the technical characteristics of each model. The appearance of the software is shown in Figure 2.

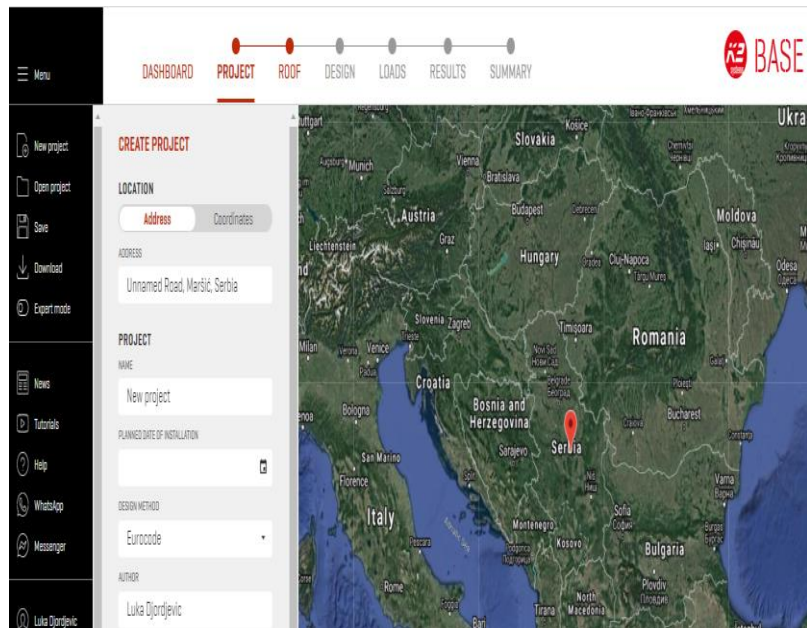


Fig. 2. K2 Base software interface

## RESULTS AND DISCUSSION

In this paper, a simulation of the possibility of installing a solar power plant on the existing roof of the building at a location located at  $20^{\circ} 39'$  east longitude and  $45^{\circ} 34'$  north latitude in the municipality of Zrenjanin.

### K2 BASE SIMULATION

The simulation of the solar power plant installation was done in K2 Base software from K2 Systems. Three power plant installation variants were examined.

For the first variant of testing, the input data are the location of the solar power plant, roof dimensions, roof type data (type of roof, building height, roof slope, distance, and dimensions of load-bearing beams) as well as the maximum possible area that can be used to install panels, in this case, 40 m<sup>2</sup> (Figure 3).

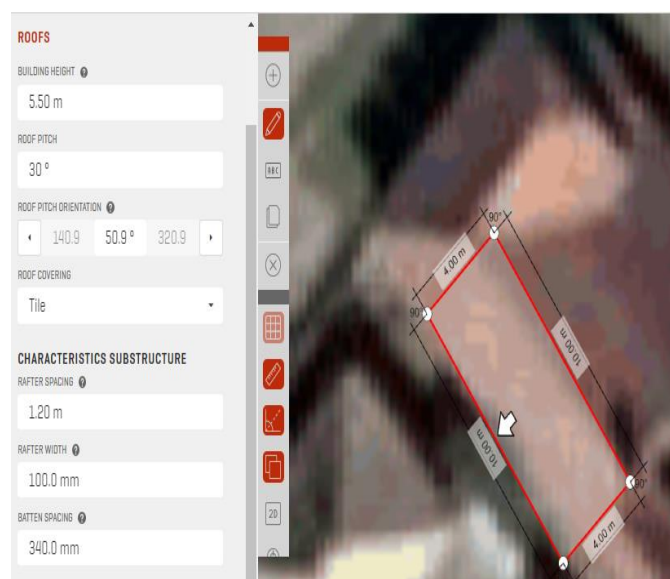
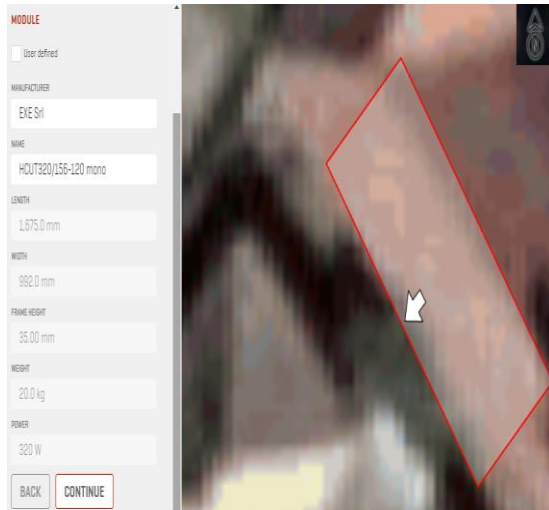


Fig. 3. Review the input data in the software in the first step

It can be seen from the figure that the software itself pulls the data on the orientation (north direction) and that the roof, which is at a slope of 30°, is oriented in the south-west direction, i.e., deviates 45° from south to west.

In the next step, the type of solar panels is selected from the software database. Panels manufactured by EXE Srl, model HCUT320 / 156-120 mono. The software retrieves the technical data on the selected panel from the database (length, width, thickness, weight, and maximum strength and efficiency) (Figures 4a and 4b).



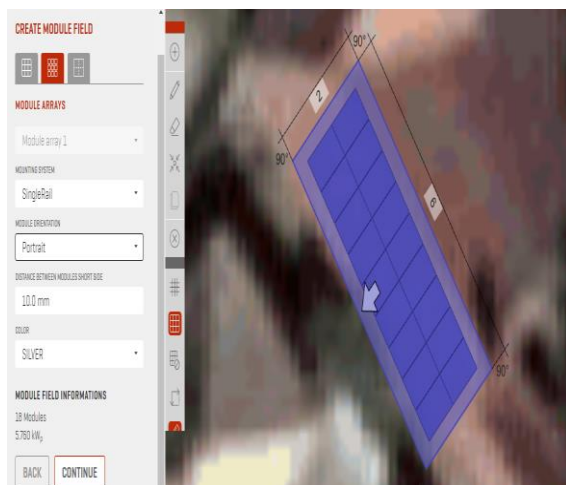
**Fig. 4a.** Panel type and technical data

STC	A+HC320/120
Maximum Power (Pmax) (W)	320
Open Circuit Voltage (Voc) (V)	40.42
Short Circuit Current (Isc) (A)	10.15
Voltage at Maximum Power (Vmpp) (V)	33.52
Current at Maximum Power (Impp) (A)	9.53
Module Efficiency (%)	18.89

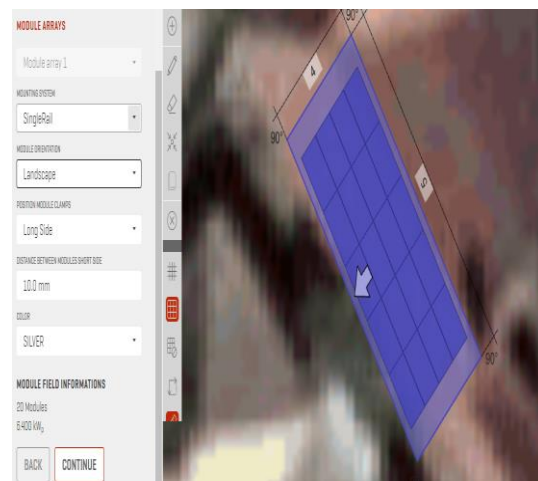
**Fig. 4b.** Maximum power and efficiency of the panel at 25°C and radiation 1000W/m<sup>2</sup>

The panels are placed parallel to the slope of the roof structure. By dragging the data on the width and length of the selected panel, the maximum utilization of the area on which the panels are placed is calculated. In the first version, the software places the panels vertically in relation to the flat roof. In this situation, it is possible to install 18 selected panels within the available roof area. The maximum power of the installed panels, in this case, is 5.76 kWp.

In the second version, the panels are placed horizontally in relation to the flat roof. It can be seen that the surface utilization, in this case, is higher and that 20 panels with a nominal power of 6.4 kWp can be installed. This setting gives 11% more utilization of solar radiation on a given surface. An illustration of the panel placement variants is given in Figures 5a and 5b.

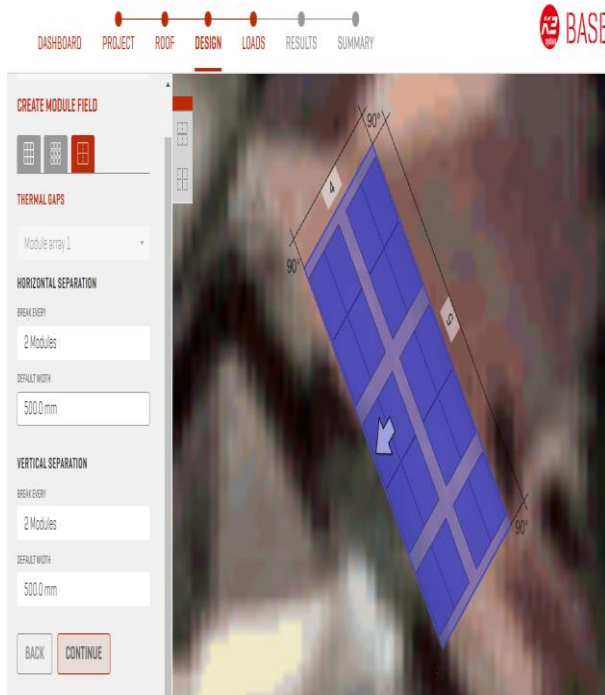


**Fig. 5a.** Vertically placed panels

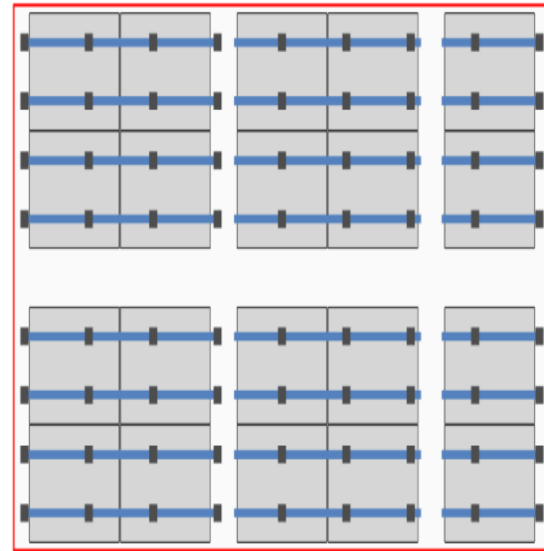


**Fig. 5b.** Horizontally placed panels

The next step allows the selected panels to be divided into segments for better distribution of the force that the roof structure suffers from the weight of the structure and the elements of the solar power plant, as well as easier access to each panel to maintain them as needed. Within this position of the used space occupied by the panels and the remaining space, six segments of panels were made, with a distance of 500 mm between each segment, in order to allow access to each panel individually. After division, the scheme of the construction on which the panels are placed is given (Figures 6a and 6b).



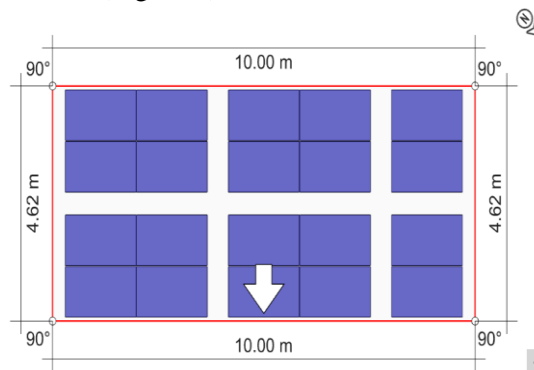
**Fig. 6a.** The final arrangement of the panels in the first variant



**Fig. 6b.** Appearance of solar power plant construction elements

In the last step, a recapitulation of the situation with the necessary investment for installing a solar power plant is given. The construction price is € 975, and the price of the selected panel is € 150 per piece, which is a total of around € 4,000 for the installation of a solar power plant with a power of 6.4 kWp.

In the test variant, the solar power plant installation position on the opposite slope of the roof is analyzed. In this variant, only the panel orientation parameters are changed, which are now set in the north-east direction, 135° deviation from the south direction. Except for the position (symmetrical in relation to the slope of the roof), other data remain unchanged, and the appearance of the power plant remains the same as in the first case (Figure 7).



**Fig. 7.** Appearance of the panel setting in the second variant with the orientation of the slope and the direction of the world

## SIMULATION IN PV GIS

By entering the input data into the PV GIS software, the power plant's location, the slope, orientation, and the installed nominal power, for the first variant of the power plant installation, it was possible to get 7,462.46 kW in one year. The average annual radiation, according to PV GIS data, is 1,494.19 kWh/m<sup>2</sup>. An overview of the PV GIS software results and the data entered is given in Figures 8a and 8b.

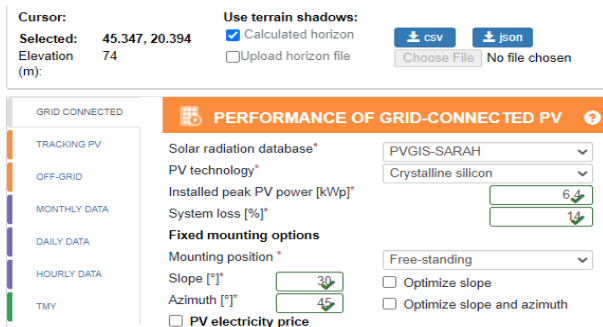


Fig. 8a. The data entered in the PV GIS software

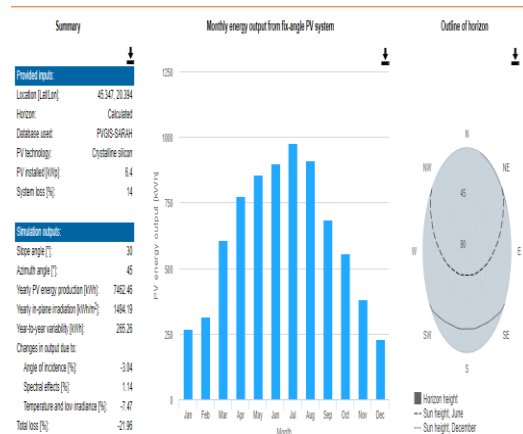


Fig. 8b. Output overview

After entering the data into the PV GIS software for the second variant of power plant installation, it is seen that it is possible to get 5,120.95 kW in one year. The average annual radiation, according to the data from PV GIS, is 1,054.17 kWh/m<sup>2</sup>. An overview of the PV GIS software results and the data entered is given in Figures 9a and 9b.

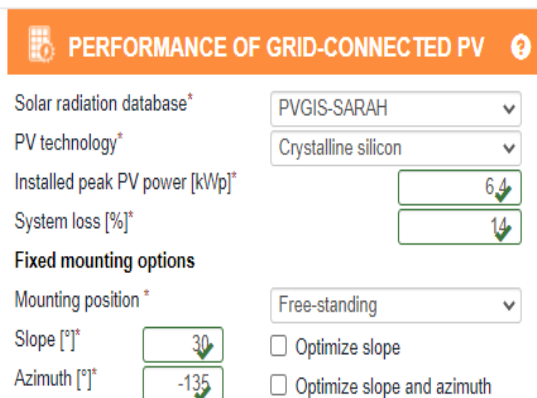


Fig. 9a. The data entered in the PV GIS software

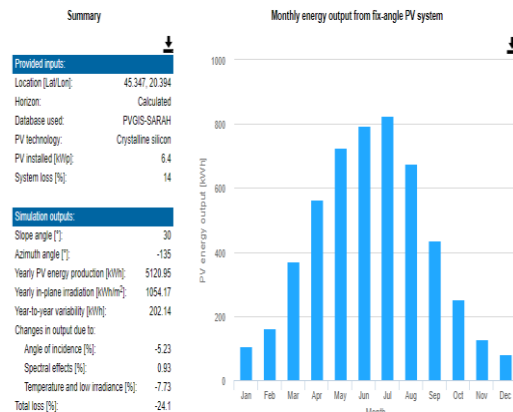


Fig. 9b. Output overview

Since the PV GIS software provides the ability to automatically select the most favorable angle of slope and orientation, after selecting this option, it can be seen that the maximum efficiency of solar radiation is possible with a panel tilt of 36° and a deviation from the south of -1°.

In this variant, it is possible to get 7932.91 kW in one year. The average radiation is 1,578.67 kWh / m<sup>2</sup>. The results obtained ideally according to the PV GIS software are shown in Figure 10.

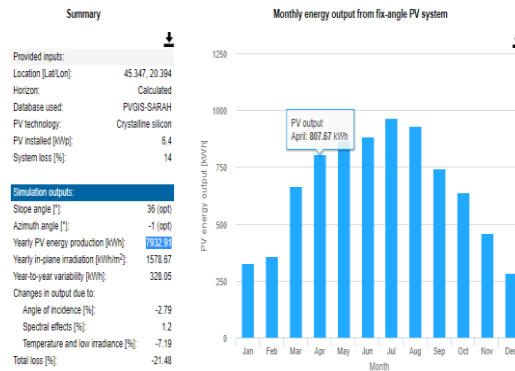


Fig. 10. Output overview

Summarizing the obtained situation by comparing the obtained data, a large difference in the obtained power is observed in variant 2. The factor that most influences this result is the largest deviation of the panel orientation from the south direction. It can be seen that the difference between the ideal installation of the solar power plant in variant 3 is 54.9% larger than variant 2. Considering the already existing roof construction, the real variant of panel installation is variant 1, due to the complicated realization of the supporting panel structure according to variant number 3. Due to the deviation from the south, the losses in electricity production of variant 1 from the ideal situation would be 470.45 kW (6.3%) on an annual basis. (Table 1).

Table 1. Review of the obtained results

Data	Var. 1	Var. 2	Var. 3
Location	20°39' IGD i 45°34' SGŠ		
Available surface	40 m <sup>2</sup> (4m x 10m)		
Installed power	6.4 kWp		
Panel manufacturer and model	EXE Srl HCUT320/156-120 mono		
Slope	30°	30°	36°
Deviation from the south	45°	135°	-1°
Average annual radiation	1.494,19 kWh/m <sup>2</sup>	1.054,17 kWh/m <sup>2</sup>	1.054,17 kWh/m <sup>2</sup>
<b>Maximum possible power output in kW</b>	<b>7.462,46</b>	<b>5.120,95</b>	<b>7.932,91</b>

Figure 11 shows the annual consumption of the household at whose location the simulation was performed. The total annual consumption of this household is 7,860 kW per year, i.e., 58,200 dinars (about 500 € per year).

We conclude that by installing a solar power plant according to variant 1 on the roof of this household, 95% of the annual electricity demand can be met..

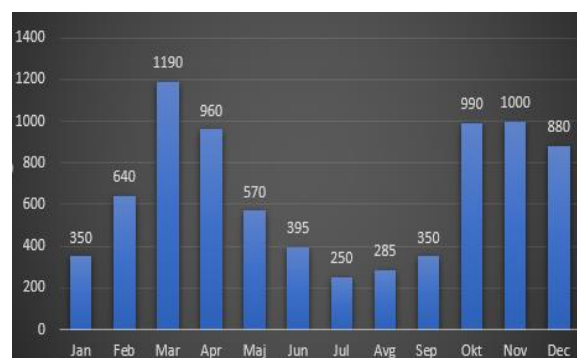


Fig. 11. Overview of household electricity consumption by months

The graph, Figure 11, shows that the highest electricity consumption is in the heating season (October - April), given that the household uses combined electricity-solid fuel heating. Until the recent introduction of the new Rulebook on energy efficiency in the Republic of Serbia, this was a problem in the full utilization of electricity produced by the solar power plant. Comparing the values obtained in each month, Figure 12 shows that the differences in potential electricity production obtained through GIS software and real consumption are large.



Fig. 12. Comparative presentation of consumption and production by months

In the months when the consumption of electricity in the household is the highest, the period October-April, the production of the solar power plant is the lowest and vice versa. In this situation, the "excess" energy that is produced and which is 2500 kW, i.e., about 30% of total annual production, can now be utilized.

## CONCLUSION

Based on the conducted analysis, it can be concluded that the orientation of the panels towards the south plays a significant role in the correct and complete utilization of the solar radiation capacity. A comparison of variants 3 and 2 shows that the difference of 54.9% is large and that such losses due to orientation are not acceptable. The possibility of setting up a power plant according to variant 1 and losses of 6.3% in relation to the ideal position are acceptable. Variants 1 and 2 refer to installing the power plant structure in parallel with the roof structure. By making a special construction of the power plant and placing it on the slope and orientation as in variant 3, it is possible to use the full potential of solar radiation.

The Government of the Republic of Serbia changed the Rulebook on energy efficiency in the Republic of Serbia in 2021, and by changing this Rulebook, it enabled every household to deliver surplus produced electricity to the EPS energy network, which has not been possible so far. This is an advantage in the cost-effectiveness of installing a solar power plant because, in this way, the entire production of electricity is used. Taking into account the estimated investment required to build this power plant of about € 4,000 and the annual household electricity consumption of about € 500, the same investment is profitable in about 8 years, after which this household becomes almost completely self-sustainable in terms of production and consumption electric energy.

## REFERENCES

- [1] Tajbar, S., Rafiq, L., Bibi, S., Saidullah, M.: Photovoltaic geographical information system module for the estimation of solar electricity generation: A comparative study in Khyber Pakhtunkhwa Pakistan, *Journal of Energy Systems*, pp. 12-21, 2020. DOI: [10.30521/jes.690717](https://doi.org/10.30521/jes.690717)
- [2] Olsan, T., Soucase, B.M., Libra, M.: Comparison of predicted and real parameters of PV systems in the Czech Republic and Spain, *Agronomy Research*, 16(S1), pp. 1150-1158, 2018.
- [3] Lewis, N., Nocera, D.: Powering the planet: Chemical challenges in solar energy utilization, *PNAS*, Vol. 103, No. 43., pp. 15729–15735, 2006.



- [4] Pekez, J.: Razvoj modela za ocenu povećanja energetske efikasnosti prijemnika sunčeve energije u dinamičkim uslovima rada, Doktorska disertacija, Zrenjanin, 2015.
- [5] IRENA: Renewable Power Generation Costs in 2019, International Renewable Energy Agency, Abu Dhabi, ISBN 978-92-9260-244-4, 2020.
- [6] Pantić, L., Pavlović, T., Milosavljević, D., Mirjanić, D., Radonjić, I., Radović, M.: Electrical energy generation with differently oriented pv modules as facade elements, Thermal Science, 2015. DOI: [10.2298/TSCI150123157P](https://doi.org/10.2298/TSCI150123157P)
- [7] Pavlović, T., et.al.: Comparison and assessment of electricity generation capacity for different types of PV solar plants of 1 MW In Soko Banja, Thermal Science, Serbia, pp. 605–618, 2011. <http://dx.doi.org/10.2298/TSCI110322065P>
- [8] Šuri, M., et al.: PV-GIS: a web-based solar radiation database for the calculation of PV potential in Europe, International Journal of Sustainable Energy, pp. 55–67, 2005.
- [9] Pagola, I., et al.: New methodology of solar radiation evaluation using free access databases in specific locations, Renewable Energy, pp. 2792–2798, 2010.
- [10] Tarai, R., Kale, P., Development of rasterized map using PVGIS for assessment of solar PV energy potential of odisha, International Journal Of Renewable Energy Research, Vol.6, No.1, pp. 61-72, 2016.
- [11] [https://everest-solarsystems.com/files/Content/Technical-information/General/Downloads/Base-manual/Bedienungsanleitung\\_K2-Base\\_GB9\\_0615\\_web.pdf](https://everest-solarsystems.com/files/Content/Technical-information/General/Downloads/Base-manual/Bedienungsanleitung_K2-Base_GB9_0615_web.pdf), 18.02.2021.

Session 3:  
**Designing and Maintenance**

## DETECTION OF INDUSTRIAL FAN MOTOR BEARING FAULTING BY IMPLEMENTATION OF VIBRODIAGNOSTIC METHODS

**Borivoj Novaković<sup>1</sup>, Ljiljana Radovanović<sup>1</sup>, Eleonora Desnica<sup>1</sup>, Luka Đorđević<sup>1</sup>,  
Mića Đurđev<sup>1</sup>**

<sup>1</sup>University of Novi Sad, Technical Faculty “Mihajlo Pupin”, Zrenjanin, Serbia  
e-mail: [borivoj.novakovic@tfzr.rs](mailto:borivoj.novakovic@tfzr.rs)

**Abstract:** This paper presents a modern approach to diagnosing the condition of machines, ie. in the specific case of electric motors on an industrial fan system. The diagnostic method that deals with checking the condition of the electric motor is the method of testing elevated vibrations on machines. Through the paper itself, the methodology of testing the system is presented, as well as the results obtained during the measurement of the machine itself and the bearings on it. The importance of modern concepts of maintenance or condition-based maintenance is described through the work itself and through the results of measurements the importance of the implementation of such types of diagnostics in the maintenance of technical systems is concluded.

**Key words:** vibrodiagnostic, bearings, electromotor, CBM.

### INTRODUCTION

Today's industrial systems require high accuracy of manufacturing sectors, less downtime, and higher profits. In order to meet this goal, each of these items must be planned and organized in detail. From the aspect of maintenance, it most directly affects potential production downtime due to certain machine failures and machine parts. In order to avoid undesirable delays, it is necessary to plan the maintenance method in a quality and detailed manner, ie. to terminate all elements related to the maintenance of technical systems, starting with people, through equipment and methods. The modern concept of maintenance according to the condition implies all this in its subassembly, but somehow the greatest focus is placed on modern diagnostic devices, which manage to predict or partially predict failures within the system. Over the last few decades, maintenance functions have drastically evolved with the growth of technology [1]. In industry, failure-driven and time-based maintenance are two major maintenance management approaches [2].

Condition based maintenance is a method that reduces the uncertainty of the operation of equipment and machines, ie increases the reliability of technical systems. According to [3], CBM can be categorized into four types, according to the level of data analytics performed: descriptive, diagnostic, predictive and prescriptive analytics. Descriptive analytics aims to understand events based on historical data, whereas diagnostic analytics investigates why an event took place. In predictive and prescriptive analytics, mathematical models are used to predict future outcomes and to pre-scribe optimal interventions, respectively [4].

A global technique called vibration-based damage assessment has been expanding rapidly in recent years [5,6]. Vibration-based condition monitoring is an important approach to ensure the reliability of industrial machines [7,8]. The vibration of electric motors is often viewed as more complicated than other rotating machines, such as pumps, fans, and compressors, even though these motors typically run at speeds below 3,500 r/min.

### METHOD OF PREDICTIVE MAINTENANCE AND APPLICATION OF VIBRODIAGNOSTICS

Predictive maintenance has been gaining prominence in multidisciplinary research groups, proposing the creation and integration of lines of research related to data acquisition, infrastructure, storage, distribution, security, and intelligence [9]. The authors [10], claim in their paper that in percentage value, the impact of maintenance on the operating costs of the entire production is even in the range of 15-60%. Conditional monitoring represents a revolution in system maintenance, as well as a methodology that within your system uses modern equipment for diagnostics. In this way, the system leads to constant monitoring, which allows to increase the productivity and efficiency of production

[11]. Predictive maintenance aims to predict the optimal time point for maintenance actions, taking into account information about the system's health state and/or historical maintenance data. It tries to avoid the premature and costly repair of a system, while at the same aiming to ensure a timely repair prior to a failure. Advanced methods aim to predict the expected time of a failure, thereby estimating the remaining useful life [12, 13]. Despite advances in predictive maintenance technologies, time-based and hands-on equipment maintenance is still the norm in many industrial processes [14].

The measurement is approached with certain measuring equipment in the form of a vibration analyzer and a sensor, such as an accelerometer. Based on the type of measurement, vibration velocities per RMS or acceleration can be measured for detailed analysis of bearings, gears. In this paper, both methods were approached, since it was determined in the initial speed measurements that the bearing was in some kind of defect. In order to analyze this in more detail, the method of measuring acceleration was approached, where a clearer picture of the condition of the bearing was obtained. Based on this measurement, it can be determined exactly in which segment the bearing is damaged. Analysis of signals obtained from measured vibrations are analyzed on the basis of already known signals.

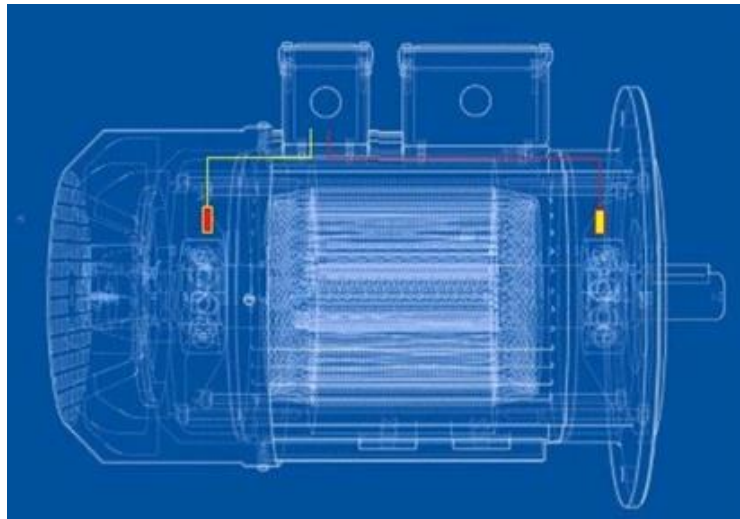
### Vibration measurement and technical diagnostic

In rotating machine, the rolling element bearings are very common to subject to unbalance force generated in machine. This leads to different types of faults in the rolling element bearings and simultaneously led to failure of the rotating machinery [15].

The complexity of the motor vibration stems from

- the motors' unique construction,
- the interaction of mechanical and electromagnetic forces,
- the thermal heating effect that is generated within them or to which they are subjected [16].

Fig. 1, shows the points of measurement of vibrations on the electric motor. Each point is measured in three axes, two radial (vertical and horizontal) and one axial. When it comes to elevated vibrations and bearing failures, they are mostly elevated in the axial direction.



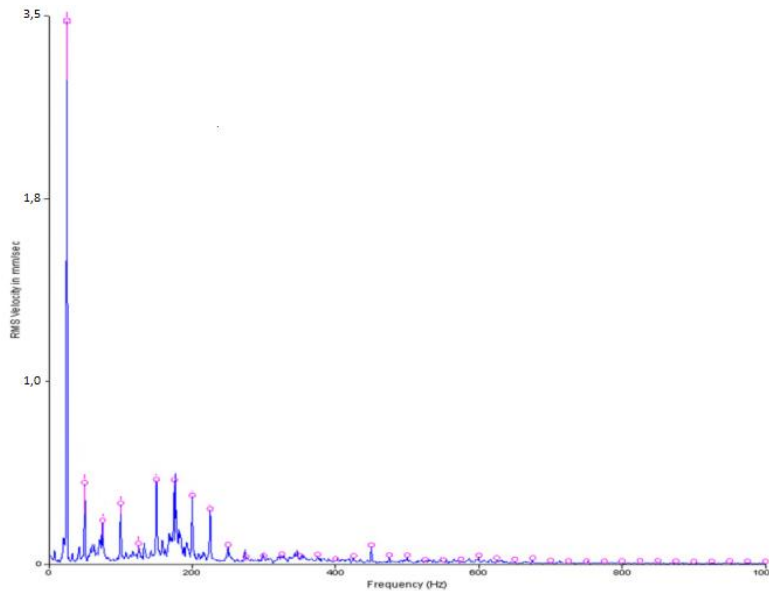
**Fig. 1.** Vibration measurement points on electric motor bearings

Fig. 1, shows two marked places that represent measurement points. The first marked place closer to the coupling represents the front bearing of the electric motor, while the second marked place represents the rear bearing of the electric motor. With electric motors with a horizontal design, mostly higher bearing loads are located at the rear, due to the fact that there is no good weakening in that part, unlike the previous bearing.

The measuring machine has the following technical specifications:

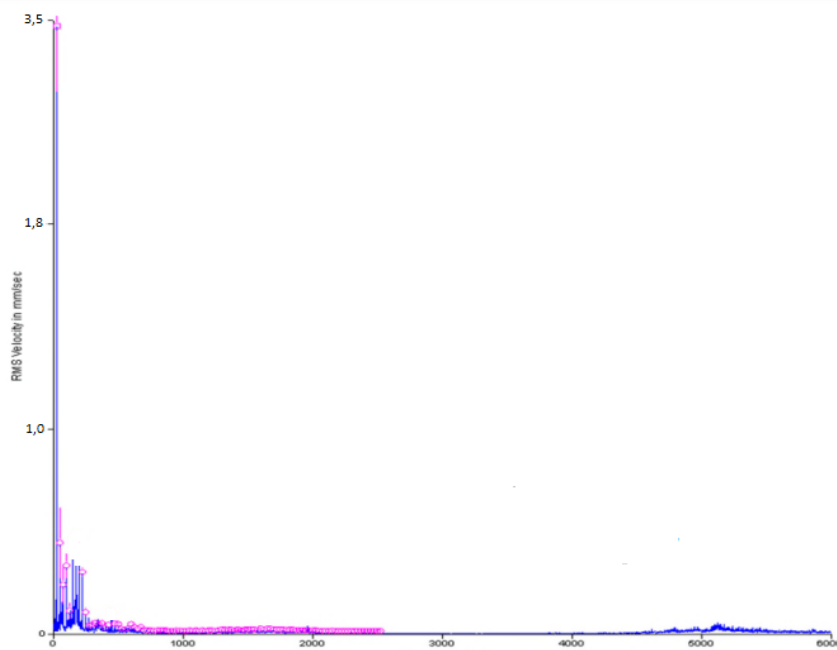
- Shaft speed: 1495 rpm,
- Frequency: 25 Hz,
- Power: 55 kW.

Fig. 2. FFT analysis of vibrations on the electromotor-fan system is shown.



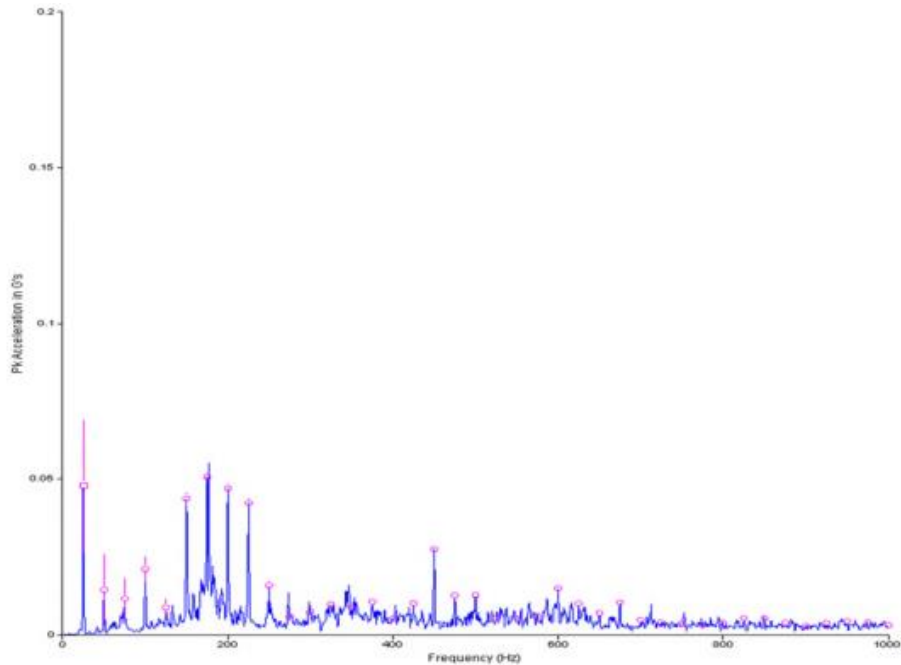
**Fig. 2.** Analysis of vibrations in the frequency range up to 1000 Hz

Fig. 2 approaches the analysis of vibrations at 1000 Hz frequency, where according to the diagram, nothing special can be concluded except the expressed 1x peak. Vibration speed is allowed, since it is a first class machine. However, continuing the RMS analysis at higher frequencies may reveal mild problems in the high frequency range, which may indicate potential problems in the system. Fig. 3, shows the spectral analysis at a frequency of 6000 Hz.



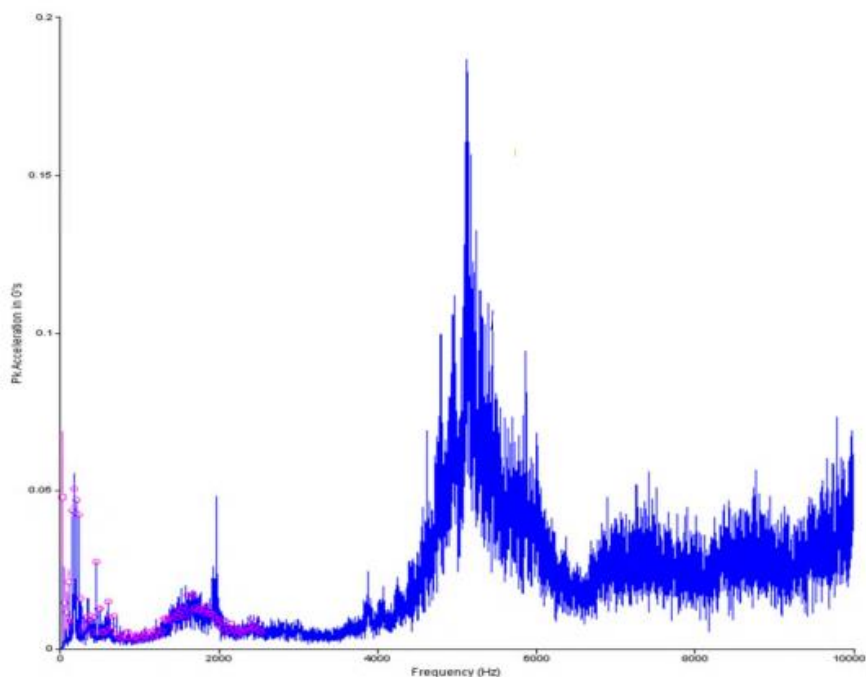
**Fig. 3.** Vibration analysis at a frequency range up to 6000 Hz.

Fig. 3, shows a more detailed analysis. can detect vibration thresholds at 6000 Hz and slightly above that. Knowing the nature of vibration behavior, it can be concluded that in this domain there are mild bearing problems at some initial stage. In order for the test to be more detailed, a G analysis of the vibration acceleration on the bearings must be performed. With the mentioned method, a clearer picture of the condition of the bearings of electric motors and fans will be obtained. Fig. 4, shows the vibration accelerations at a frequency of 1000 Hz.



**Fig. 4.** Analysis of vibration acceleration in the frequency range up to 1000 Hz

In Fig. 4, peaks can be seen at higher frequencies, however, except that the bearing may have a problem, nothing can be concluded in more detail. However, by more detailed analysis, at higher frequencies, such as the frequency of 10000 Hz, we can analyze the precise ball bearing defect. Fig. 5, shows the spectral analysis of vibrations at a frequency of 10000 Hz.



**Fig. 5.** Analysis of vibration acceleration at a frequency range up to 10000 Hz

---

Fig. 5, clearly shows that there is an indication of bearing failure. Knowing the failure frequency of the bearing elements, detailed analysis, it is determined that in this case there was a failure of the inner ring of the bearing. In this case, the bearing is ready for replacement, but it is necessary to solve the problem as a whole, since there is a slight unbalance of the impeller in the system.

The corrective measure with the replacement of the bearing with an adequate type is certainly the check of the unbalance of the impeller, as well as the laser check of the alignment of the re-installed system. If the stated corrective measures are not taken, before the release of the repaired system, there is a very high probability that the most loaded parts of the system, ie. bearings get into a similar problem. Of course, with an adequate approach, the service life of the bearings will be extended, with a quality lubrication process.

## CONCLUSION

It can be concluded that the CBM maintenance concept must be approached thoroughly and in detail and that the concept should focus on a few basic steps and modules, i.e., on diagnostics and decision support. The implementation of modern diagnostic methods reduces the risk of unforeseen system conditions, which further directly affects the reduction of production costs. The costs of unforeseen downtime are considered to be the largest losses that may occur in relation to production, and directly related to the maintenance process. According to this conclusion, it is necessary to have an appropriate technique of predictive maintenance within the system, only a completely correct machine can meet modern market conditions. Industrial systems should no longer be left to the corrective way of maintaining machines, but it is necessary if they want stable production to implement one of the methods of translating the condition of machines.

## REFERENCES

- [1] Ahmad, R., Kamaruddin, S.: An overview of time-based and condition-based maintenance in industrial application. *Computers & Industrial Engineering*, 63(1), pp. 135–149, 2012. [doi:10.1016/j.cie.2012.02.002](https://doi.org/10.1016/j.cie.2012.02.002)
- [2] Yam, R. C. M., Tse, P. W., Li, L., Tu, P.: Intelligent Predictive Decision Support System for Condition-Based Maintenance, *The International Journal of Advanced Manufacturing Technology*, 17(5), pp. 383–391, 2001. [doi:10.1007/s001700170173](https://doi.org/10.1007/s001700170173)
- [3] Ingemarsdotter, E., Kambanou, M. L., Jamsin, E., Sakao, T., Balkenende, R.: Challenges and solutions in condition-based maintenance implementation-A multiple case study, *Journal of Cleaner Production*, 296, pp.126420, 2021. <https://doi.org/10.1016/j.jclepro.2021.126420>
- [4] Baum, J., Laroque, C., Oeser, B., Skoogh, A., Subramaniyan, M.: Applications of big data analytics and related technologies in maintenance—literature-based research, *Machines*, 6(4), pp. 54, 2018. <https://doi.org/10.3390/machines6040054>
- [5] Seguel, F., Meruane, V.: Damage assessment in a sandwich panel based on full-field vibration measurements, *Journal of Sound and Vibration*, 417, pp. 1-18. <https://doi.org/10.1016/j.jsv.2017.11.048>
- [6] Hayman B.: Approaches to Damage Assessment and Damage Tolerance for FRP Sandwich Structures, *Journal of Sandwich Structures & Materials*, 9(6), pp. 571-596. [doi:10.1177/1099636207070853](https://doi.org/10.1177/1099636207070853)
- [7] Milovančević, M., Nikolić, V., Petkovic, D., Vracar, L., Veg, E., Tomic, N., Jović, S.: Vibration analyzing in horizontal pumping aggregate by soft computing, *Measurement*, 125, pp. 454-462. <https://doi.org/10.1016/j.measurement.2018.04.100>
- [8] Huang, Q., Tang, B., Deng, L.: Development of high synchronous acquisition accuracy wireless sensor network for machine vibration monitoring, *Measurement*, 66, pp.35-44, 2015, <https://doi.org/10.1016/j.measurement.2015.01.021>
- [9] Zonta, T., da Costa, C. A., da Rosa Righi, R., de Lima, M. J., da Trindade, E. S., Li, G. P.: Predictive maintenance in the Industry 4.0: A systematic literature review, *Computers & Industrial Engineering*, 150, pp. 106889, 2020. [doi:10.1016/j.cie.2020.106889](https://doi.org/10.1016/j.cie.2020.106889)
- [10] Haarman, M., Mulders, M., Vassiliadis, C.: Predictive maintenance 4.0, Predict the unpredictable, PwC and Mainnovation, 2017.

- [11] Novaković, B., Radovanović, Lj., Žikić, D., Vlačić, S.: Conditional Monitoring in Industry 4.0, X International Symposium Engineering Management and Competitiveness (EMC 2020), pp. 93-97, Zrenjanin, 2020.
- [12] Theissler, A., Pérez-Velázquez, J., Kettelgerdes, M., Elger, G.: Predictive maintenance enabled by machine learning: Use cases and challenges in the automotive industry, Reliability Engineering & System Safety, 215, pp. 107864, 2021. <https://doi.org/10.1016/j.ress.2021.107864>
- [13] Li, X., Ding, Q., Sun, J. Q.: Remaining useful life estimation in prognostics using deep convolution neural networks, Reliability Engineering & System Safety, 172, pp. 1-11, 2018. <https://doi.org/10.1016/j.ress.2017.11.021>
- [14] Hashemian, H.: State-of-the-Art Predictive Maintenance Techniques, IEEE Transactions on Instrumentation and Measurement, 60(1), pp. 226–236, 2011. [doi:10.1109/tim.2010.2047662](https://doi.org/10.1109/tim.2010.2047662)
- [15] Khadersab, A., Shivakumar, S.: Vibration analysis techniques for rotating machinery and its effect on bearing faults, Procedia Manufacturing, 20, pp. 247-252, 2018. <https://doi.org/10.1016/j.promfg.2018.02.036>
- [16] Hashish, E., Miller, K., Finley, W., Kreitzer, S.: Vibration Diagnostic Challenges: Case Studies in Electric Motor Applications, IEEE Industry Applications Magazine, 23(4), pp.22–34, 2017. [doi:10.1109/mias.2016.2600718](https://doi.org/10.1109/mias.2016.2600718)



## CONDITION MONITORING AND DIAGNOSTICS OF SLIDING BEARINGS

Ranko Antunović<sup>1</sup>, Nikola Vučetić<sup>1</sup>, Eleonora Desnica<sup>2</sup>, Imre Kiss<sup>3</sup>

<sup>1</sup>University of East Sarajevo, Faculty of Mechanical Engineering, East Sarajevo, Bosnia and Herzegovina

<sup>2</sup>University of Novi Sad, Technical Faculty "Mihajlo Pupin", Zrenjanin, Serbia

<sup>3</sup>University Politehnica Timisoara, Faculty of Engineering Hunedoara, Romania  
e-mail: [rankoantunovicmf@gmail.com](mailto:rankoantunovicmf@gmail.com)

**Abstract:** The main causes that lead to damage and failure of sliding bearings include many aspects of construction, material selection, material imperfections, production and processing, assembly, control, testing, storage, transport, maintenance, unforeseen exposure to overload, direct mechanical or chemical damage. Failures and damages caused by the mentioned groups of causes are most often manifested as wear, breakage and plastic deformation of the material. These are at the same time the basic types of failures, which can be divided, in relation to the properties of the material, into two categories. One that is connected and depends primarily on the strength of the material and the other that is a function of tribological processes on the coupled surfaces of the housing-sleeve. The main advantage of sliding bearings is reflected in their bearing capacity and service life, on the correct operation of which depends the availability of these technical systems and the study of methods for predicting the failure of sliding bearings today is given much attention.

**Key words:** sliding bearings, vibrations, diagnostics, failure prediction

### INTRODUCTION

Sliding bearings serve as supports for shaft sleeves and shafts. In bearings, the load is transferred from the shaft sleeve and the shaft to the placenta (bearing sleeve). Radial and axial plain bearings are distinguished according to the action of the load.

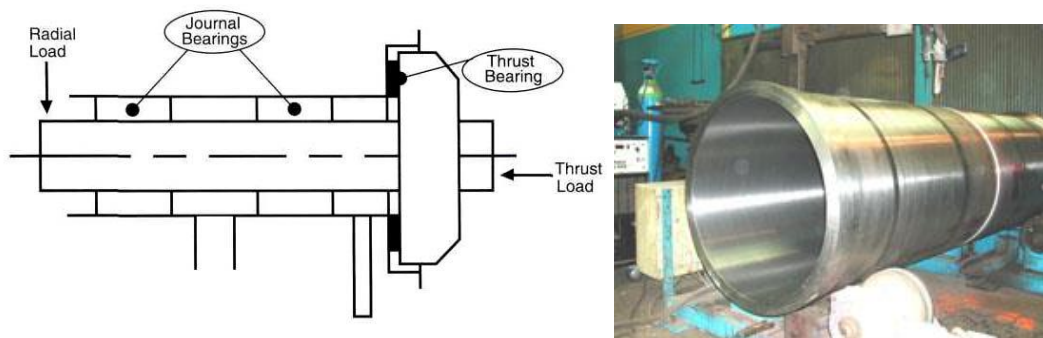


Fig. 1. Journal bearings

Sliding surfaces are lubricated with oil and less often with grease or solid lubricants. Hydrodynamic lubrication with oil is ideal, because then the sliding surfaces are not worn out. Grease lubrication is used for low-load, secondary bearings, and oil lubrication is suitable for all high-speed bearings with high surface pressures and higher temperatures. Grease lubrication can be manual or with automatic lubrication devices, and oil immersion lubrication is simple, safe and economical. Circulating lubrication is also used, which uses a pump and all bearing points are lubricated via a pipe system. In this way, in addition to lubrication, cooling of the bearing can also be achieved.

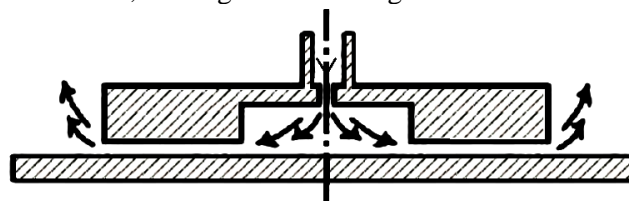
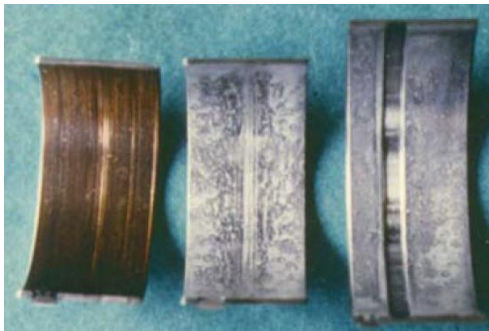


Fig. 2. Hydrostatic lubrication of axial plain bearing

During hydrodynamic lubrication, the surfaces of the sleeve and the placenta are separated by a layer of lubricant. This bearing film of lubricant is formed between the sliding surfaces due to the relative movement of the surfaces, if the relative sliding speed is sufficiently high between the sliding surfaces. In order to minimize damage and failure of plain bearings and thus ensure high reliability of equipment operation, monitoring of bearing condition proves necessary. The methods of monitoring the condition of the bearings are divided into two groups, namely the methods that are applied to the bearings in the bend, i.e. bearings whose sleeve rotates and bearings out of operation, i.e. beds at rest. Of course, this division is conditional, because e.g. lubricant analysis can often be performed on the bearing in operation. The methods applied to the bearings in the operating mode are [1-13]:

- measurement and analysis of vibrations,
- measurement of ultrasonic emission intensities,
- temperature measurement,
- lubricant analysis and
- measuring the thickness of the oil film

Visual recognition of the manifestations of sliding bearing failures is also an important element in the diagnosis of failures. As an illustration in the following figures. Examples of the appearance of damage to the surfaces of plain bearings that most often occur in practice are given, Fig. 3-11.



**Fig. 3.** Abrasive wear



**Fig. 4.** Heavy adhesive wear (sealing)



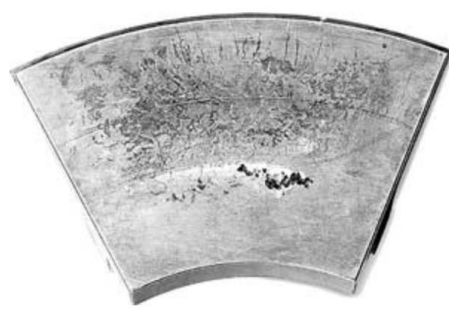
**Fig. 5.** Erosion due to the flow of electric current through the bearing



**Fig. 6.** Material fatigue



**Fig. 7.** Axial sliding bearing placental fatigue



**Fig. 8.** Placental damage caused by cavitation in oil



**Fig. 9.** Oxidation of the placenta due to contamination of lubricants with aggressive substances



**Fig. 10.** Placental deformities caused by overheating

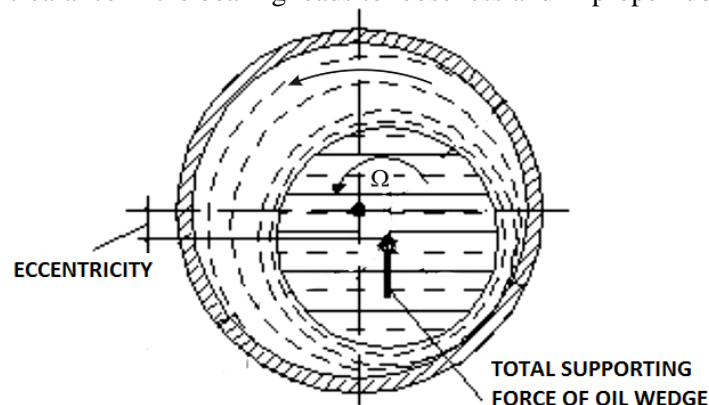


**Fig. 11.** Trace of lubricant burn on the placenta

Measuring the clearance of a plain bearing is one of the methods used to check the condition of the bearing. Permitted clearance ranges are determined for each application and e.g. a gap in the range of 0.1-0.3mm is taken as good, a gap of 0.3-0.5mm is taken as satisfactory and a gap above 0.5mm is bad.

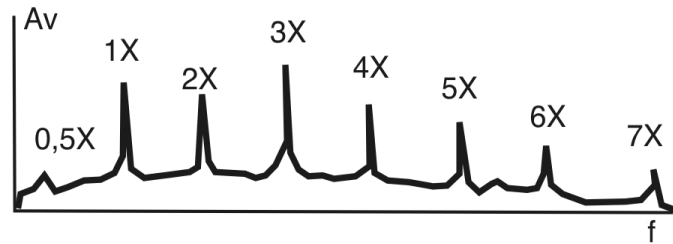
### DIAGNOSTICS OF SLIDING BEARING DAMAGE

Problems that occur with plain bearings lead to high levels of vibration and noise. These problems mainly occur as a result of inadequate bearing clearance (oil clearance) or the occurrence of oil instability. Excessive clearance in the bearing leads to looseness and improper lubrication [13-18].



**Fig. 12.** Analysis of rotor sleeve movement in sliding bearing

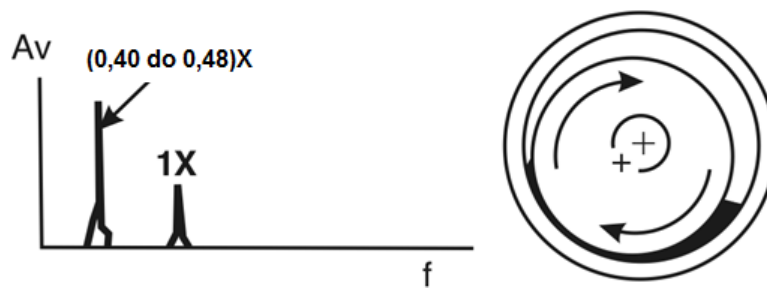
An excessive clearance sliding bearing, which mainly occurs as a result of wearing white metal, causes a relatively small imbalance, a centric disturbance, or some other disturbing force that will cause mechanical looseness.



**Fig 13.** Spectral display in the presence of excessive clearance in the plain bearing

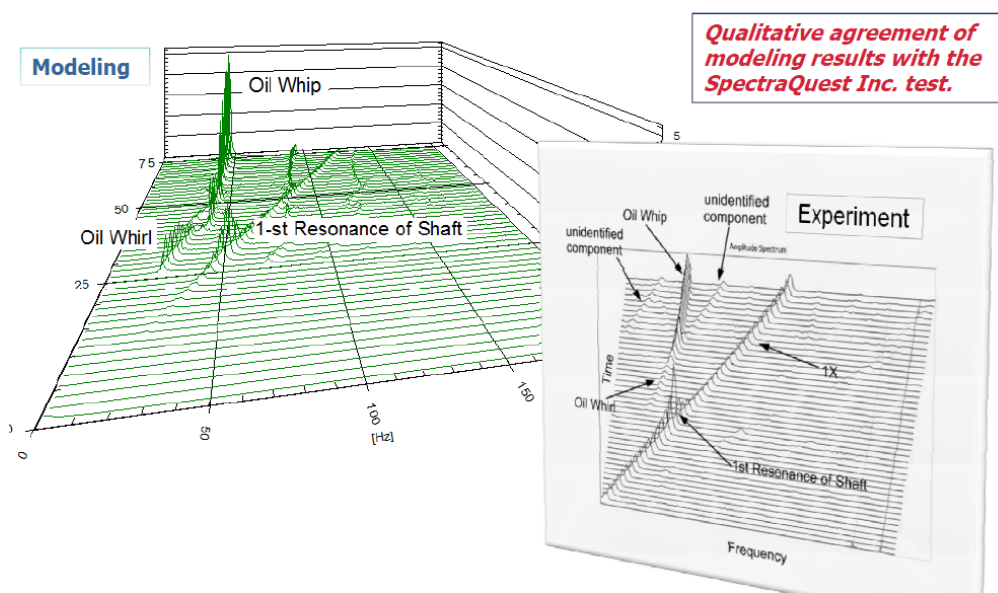
Oil instability is manifested in the appearance of an oil vortex and an oil whip. The oil vortex occurs as a result of the orbital motion of the rotor and occurs at a frequency that is proportional to the speed of rotation and is (usually 0.4 to 0.5) with increasing amplitude as the number of revolutions increases.

**RADIAL VIBRATIONS**



**Fig. 14.** Spectral representation in the presence of oil instability

In machines operating above the first critical speed, the oil vortex usually turns into an oil whip, the frequency of which is equal to the frequency at the moment of its formation. The lowest rotational speed at which fluid instability occurs, and this theoretically occurs in the case of zero eccentricity, is called the stability threshold. In real rotary machines, the eccentricity is significantly higher than 0 (usually 0.4 to 0.6). However, due to the action of unidirectional forces on the rotor (such as forces due to coupling eccentricity, fluid forces due to working fluid, electrical forces, etc.), the rotor sleeve can be brought into the bearing axis and then the mean eccentricity approaches zero. These problems are most easily observed by monitoring the cascading spectral display during machine start-up, as in Figure [15].



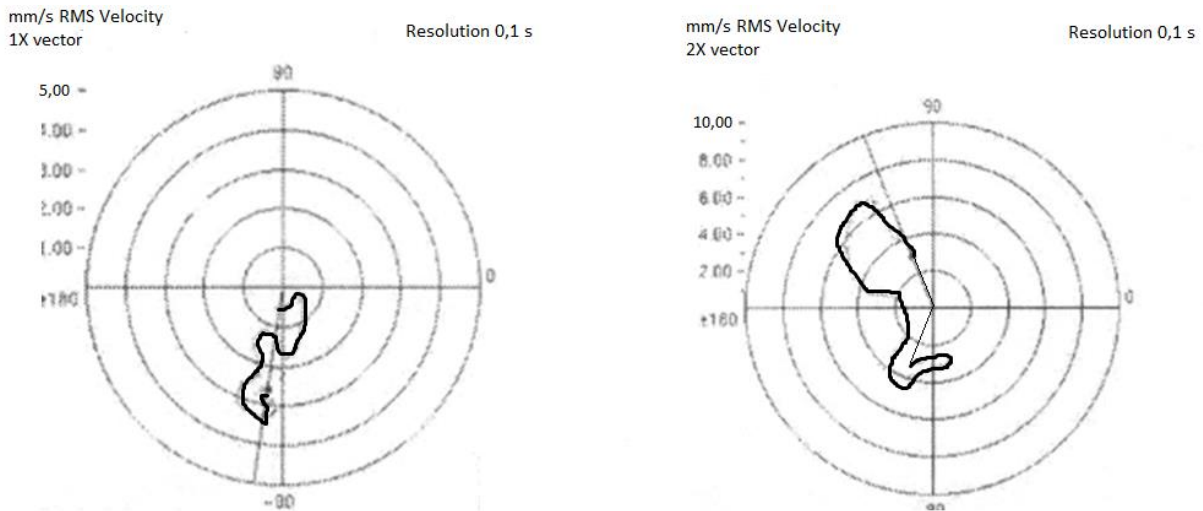
**Fig. 15.** Cascade spectral display in the case of oil instability

Bearing temperature measurement is necessary to determine possible bearing overheating. The cause of overheating of the sliding bearing can be poor lubrication, misalignment, overload, and also the bearing can overheat due to the presence of an external heat source.

## CASE STUDY

### Failure analysis of turbogenerators sliding bearing in TPP Gacko

With the shutdown of the oil pumps for lubricating the turboaggregate bearings, the oil pressure in the bearings dropped. Immediately after that there is an increase in rotor deflection (see a marked increase in 1X vibration component), and after ten seconds there is a serious scraping of the rotor arm and white metal on bearing 7, visible in the response of 1X and 2X vibration vectors, Fig.16.



**Fig.16.** Vibration vector change 1X and 2X

It should be noted that the temperature of the white metal in a few tens of seconds exceeded the range of the temperature sensor 112°C, which is also a symptom of severe scraping of the rotor sleeve and white metal on bearing 7. After dismantling the bearing, traces of scraping on the rotor sleeve and an increase in the hardness of the material on the sleeve part were observed.

Traces of damage to part of the white metal surface on the lower half of the insert are visible on the first bearing (Fig. 17). According to the nature of the damage, it is clear that it is electro-erosion corrosion that occurs due to the breakthrough of eddy currents from the rotor to the stator part. Bearing repair consists of showering the bearing surface, adjusting to the caliber and reassembling.



**Fig. 17.** Appearance of damage to the white metal on the sleeve

The removal of white metal on the lower half of the surface of the sliding bearing due to the collapse of the rotor of 0.16 mm is also visible.

#### Failure analysis of turbocharged pump sliding bearing in TPP Gacko

By monitoring the vibrations on bearing No. 1 of the Turbocharged PUMP in TPP Gacko, an increase in the total vibration level was observed. Vibration spectrum analysis could clearly show the dominant presence of vibration harmonics at (0.4) 1X, Fig.18.

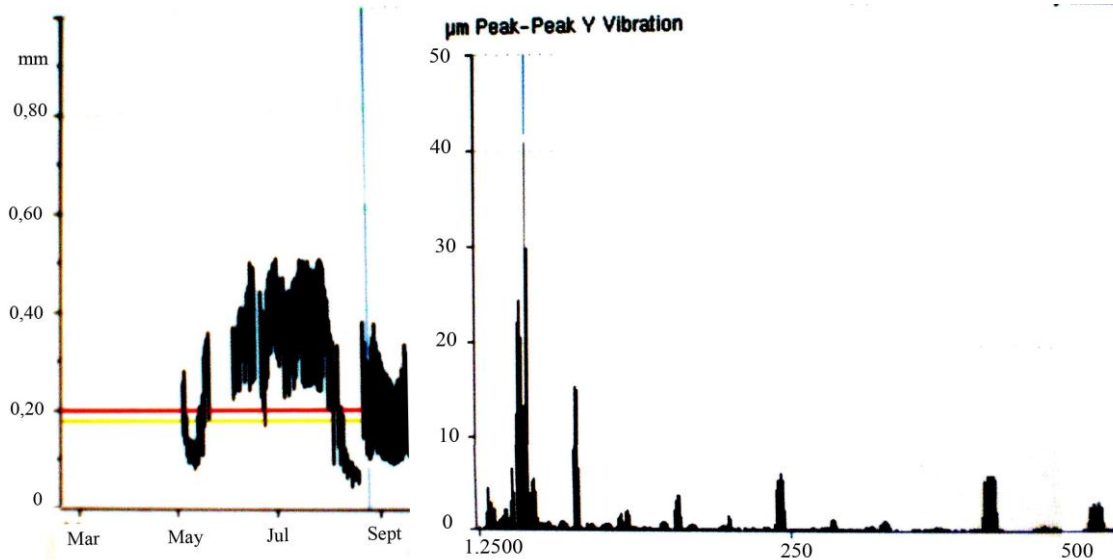


Fig. 18. Rotor vibration level and spectral display

It could be unequivocally concluded that this is a problem of inadequate oil film and bearing damage. After the bearing was inspected, the damage was clearly noticed and a new "lemon" bearing was made, which proved to be a good solution, Fig. 19.



Fig. 19. Sliding bearing damage (left) and appearance of new "lemon" bearing (right)

## CONCLUSION

The use of advanced technologies sets the possibility to significantly reduce the duration of measurements, and on the other hand to increase the accuracy of diagnostic methods. There are a number of causes that can lead to plain bearing failure. The most common cause of failure is inadequate and insufficient lubrication of the plain bearing. The two most important indicators for the prediction of bearing failure are the analysis of the dynamic behavior of the bearing (vibration analysis) and the analysis of the bearing temperature (thermal method). Maintenance according to the condition, i.e. proactive maintenance of the entire system, including plain bearings, will provide significant technical and economic effects.

## REFERENCES

- [1] Antunović, R., Halep, A.: Defekt faktor kliznih ležaja, Konferencija "Održavanje 2014", Zenica, BiH, p. 97-101, 2014.
- [2] Rac, A.: Praćenje stanja i dijagnostika otkaza kliznih ležaja, Osma internacionalna konferencija o tribologiji, Beograd, pp. 271-275, 2003.
- [3] Patrick, G. S.: Studies in plain bearing failures, Technical Analysis, Tribology & Lubrication Technology, pp. 28-31, 2006.
- [4] Bartz, W.: The Influence of Lubricants on Failures of Bearings and Gears, Tribology International 9 (5), 213-224, 1976.
- [5] Group of authors, Handbook of Loss Prevention, Springer-Verlag, 1978.
- [6] Lamjua, P.: Tribological Behaviour Study of Sliding Bearing of Leaded Red Brass, Bangkok (Thailand): King Mongkut's Institute of Technology North Bangkok, Doctoral Thesis, 2006.
- [7] [www.neotehnika.co.rs](http://www.neotehnika.co.rs) (30.07.2018)
- [8] Rac, A.: Praćenje stanja i dijagnostika otkaza kliznih ležaja, Proceedings of the 8<sup>th</sup> International Tribology Conference, Belgrade, Serbia; 8-10 October, pp. 271-275, 2003.
- [9] Antunović, R.: Rotor dynamic models with sliding bearings, Internacional Scientific Professional Symposium, Infoteh-Jahorina, Vol. 10, Ref. C-7, pp. 268-272, 2011.
- [10] San Andrés, L., Rivadeneira, L., Gjika, K., Groves, C., LaRue, G.: A virtual tool for prediction of turbocharger nonlinear dynamic response, ASME Paper GT2006-90873, 2006.
- [11] Desnica, E., Arsić, G., Đurđev, M.: Test and control methods for bearings in mining exploitation for increasing system reliability, 27. International scientific and professional conference Organisation and maintenance technology OTO 2018, Osijek, pp. 1-8, 2018.
- [12] Luštinec, J., Očenášek, V., Ke, J.: Damage of the CuPb20 sliding bearing, Applied Engineering Letters, Vol. 2, No. 1, pp. 16-21, 2017.
- [13] Radil, K., Zeszotek, M.: An Experimental Investigation into the Temperature Profile of a Compliant Foil Air Bearing, Tribology Transactions 47 (4) 470-479, 2004.
- [14] Dadouche, A., Conlon, M.: Operational performance of textured journal bearings lubricated with a contaminated fluid, Tribology International 93, 377-389, 2016.
- [15] Singla, A., et al.: Experimental Determination of Temperature and Pressure Profile of Oil Film of Elliptical Journal Bearing, International Journal of Advanced Mechanical Engineering 4 (5), 469-474, 2014.
- [16] Antunović, R., et al.: Mathematical Model for Temperature Change of a Journal Bearing, Thermal science, Vol. 22, No. 1A, pp. 323-333, 2018.
- [17] Antunović, R. et al.: Vibration and Temperature Measurement Based Indicator of Journal Bearing Malfunction., Tehnički vjesnik/Technical Gazette, Vol.25, No.4(2018), pp. 991-996, 2018.
- [18] Antunović, R., Veg, A.: Analysis of dynamic behavior of rotating machines, Annals of Faculty Engineering Hunedoara - International Journal of Engineering, Tome XII, No. 9, Vol 2, pp. 205-210, 2014.

Session 4:  
**Oil and Gas Engineering**



## RESULTS OF EXPERIMENTAL RESEARCH OF HEAT TRANSFER COEFFICIENT THROUGH THE MAIN OIL PIPELINE

Jasna Tolmac<sup>1</sup>, Slavica Prvulovic<sup>1</sup>, Sasa Jovanovic<sup>1</sup>, Milan Markovic<sup>1</sup>, Dragisa Tolmac<sup>2</sup>

<sup>1</sup>University of Novi Sad, Technical Faculty "Mihajlo Pupin", Zrenjanin, Serbia

<sup>2</sup>University Union - Nikola Tesla, Belgrade, Faculty of Management, Sremski Karlovci, Serbia

e-mail: [jasnatolmac@yahoo.com](mailto:jasnatolmac@yahoo.com)

**Abstract:** The results of experimental research of the heat transfer coefficient refer to the main oil pipeline with a length of 91000 m and a diameter of 457 mm, with non-isothermal flow of crude oil. Transmission coefficient, through the pipeline has a dominant influence on the cooling rate of the oil in the pipeline. The thickness of the pipeline isolation has the greatest influence on the value of the heat transfer coefficient. With a decrease in the thickness of the pipeline isolation, there is an increase in the heat transfer coefficient and heat losses. During transport, the oil cools and transfers its heat to the environment. Within the results of experimental research, numerical values and interdependencies were determined: heat transfer coefficient ( $k$ ) and pipeline isolation thickness ( $s$ ), as well as heat conduction coefficient ( $kD_m$ ) and pipeline isolation thickness ( $s$ ), and their interdependencies were given.

**Key words:** heat transfer coefficient, heat conduction coefficient, isolation thickness, pipeline diameter

### INTRODUCTION

The paper presents the results of experimental research of the heat transfer coefficient through the main oil pipeline, with non - isothermal flow of crude oil. Viscous fluids, such as crude oil, are preheated before being introduced into the pipeline. Oil transport is performed by a main oil pipeline with a length of  $l = 91000$  m and a diameter of  $D_{ca} = 457$  mm.

Heated crude oil, when flowing through the pipeline, cools and transfers its heat to the environment. The temperature to which crude oil is cooled is of great practical importance. Cooling of the heated crude oil is generally performed to a temperature above the pour point.

The heat transfer coefficient through the oil pipeline depends on the flow regime, physical properties of the transported crude material, geological composition of the ground through which the oil pipeline passes and the type and quality of isolation. The heat transfer coefficient through the pipeline has a dominant influence on the oil cooling rate in the pipeline. The thickness of the pipeline isolation has the greatest influence on the value of the heat transfer coefficient.

Within the results of experimental research, numerical values and interdependencies were determined: heat transfer coefficient ( $k$ ) and pipeline isolation thickness ( $s$ ), as well as heat conduction coefficient ( $kD_m$ ) and pipeline isolation thickness ( $s$ ), and their interdependencies were given.

### MATERIAL AND METHODS

#### Determination of heat transfer coefficient through oil pipeline with diameter $D_{ca} = 457$ mm

The heat transfer coefficient is determined by the equation (1). This equation defines the complex mechanism of heat transfer from heated crude oil inside the pipeline to the environment.

The heat transfer coefficient is determined by the following equation, [1], [2]:

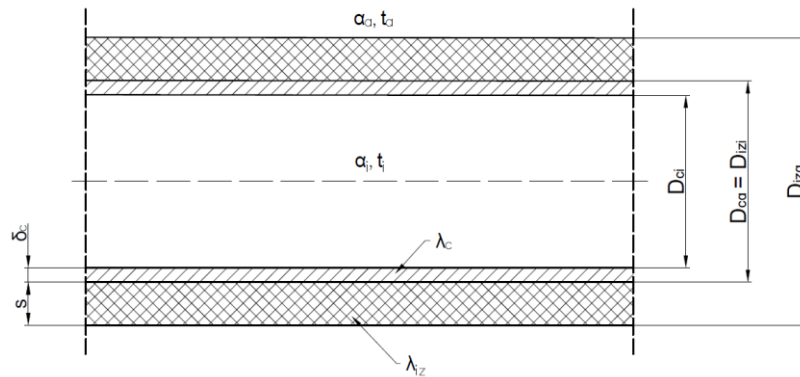
$$\frac{1}{kD_m} = \frac{1}{\alpha_i D_{ci}} + \frac{1}{2\lambda_c} \ln \frac{D_{ca}}{D_{ci}} + \frac{1}{2\lambda_{iz}} \ln \frac{D_{iza}}{D_{izi}} + \frac{1}{\alpha_a D_{iza}} \quad (1)$$

where is :

$$D_m = \frac{D_{ci} + D_{iza}}{2} \quad (m) - \text{middle diameter of the pipeline with isolation,}$$

- $\alpha_i$  (W/m<sup>2</sup>K) – heat transfer coefficient from the transported crude material to the pipeline,
- $\lambda_c$  (W/mK) – pipeline heat conduction coefficient,
- $\lambda_{iz}$  (W/mK) – isolation heat conduction coefficient,
- $\alpha_a$  (W/m<sup>2</sup>K) – heat transfer coefficient from the pipeline to the environment,
- $D_{ci}$  (m) – inner diameter of the pipeline,
- $D_{ca}$  (m) – outer diameter of the pipeline,
- $D_{izi}$  (m) – inner diameter of isolation,
- $D_{iza}$  (m) – outer diameter of isolation.

Pipeline diameters with isolation are shown in Fig. 1.



**Fig. 1.** Pipeline diameters with isolation

The heat transfer coefficient ( $k$ ) includes the heat transfer by convection from the transported crude oil to the pipeline wall, then the conduction through the pipeline wall and isolation, as well as the heat transfer from the isolation to the environment.

Based on that, the heat transfer coefficient ( $k$ ) through the pipeline depends on several parameters such as: inner diameter of the pipeline ( $D_{ci}$ ), pipeline wall thickness, isolation thickness ( $s$ ), middle diameter of the pipeline with isolation ( $D_m$ ), heat transfer coefficient from the transported crude oil to pipeline ( $\alpha_i$ ), loss coefficient for buried oil pipeline in the ground ( $\alpha_a$ ).

The basic characteristics of the main oil pipeline are given in Table 1.

**Table 1.** Characteristics of the main oil pipeline with outer diameter  $D_{ca} = 457$  mm

The parameters	Values
The inner diameter of the pipeline	$D_{ci} = 428,4$ mm
Pipeline wall thickness	$\delta_c = 14,3$ mm
The length of the pipeline	$l = 91000$ m
Isolation thickness	$s = 100$ mm

By analyzing equation (1), which defines the heat transfer coefficient ( $k$ ), through the pipeline it can be seen that all influential parameters that depend on the construction of the pipeline are constants for the main pipeline, except for the loss coefficient for buried pipeline ( $\alpha_a$ ), equation (2) and the heat transfer coefficient from the transported crude oil to the pipeline ( $\alpha_i$ ), relation (3).

The coefficient of losses for a buried oil pipeline in the ground is determined on a known relation to [3], [4]:

$$\alpha_a = \frac{2\lambda_{iz}}{D_{iza} \ln \frac{4h}{D_{iza}}} \quad (2)$$

where is:

$\lambda_t = 1,764 \text{ W/mK}$  – thermal conductivity of the ground,  
 $D_{iza}$  (m) – outer diameter of isolation,  
 $h$  (m) – the depth at which the pipeline is laid in the ground.

The heat transfer coefficient depends on the flow regime and physical properties of the transported crude oil [3], [4]:

$$\alpha_i = \frac{\lambda_n Nu}{D_{ci}} \quad (3)$$

where is:

$\lambda_n$  (W/mK) – the heat conduction coefficient of crude oil,  
 $Nu$  – Nusselt's number,  
 $D_{ci}$  (m) – inner diameter of the pipeline.

The average value of thermal conductivity of oil on standard conditions is  $\lambda_n = 0,12 \text{ W/mK}$ , [4]. According to [5], [6], [7], heat conduction coefficient of steel pipeline is  $\lambda_c = 46,5 \text{ W/mK}$  and heat conduction coefficient of polyurethane foam isolation is  $\lambda_{iz} = 0,05 \text{ W/mK}$ . Heat transfer coefficient from the pipeline to the environment ( $\alpha_a$ ) is determined by equation (2) and is  $\alpha_a = 2,97 \text{ W/m}^2\text{K}$ , for the depth of pipeline burial  $h = 1 \text{ m}$  and the outer diameter of the isolation  $D_{iza} = 657 \text{ mm}$ , ie. when the isolation thickness is  $s = 100 \text{ mm}$ .

## RESULTS AND DISCUSSION

Within the results of experimental research, numerical values and interdependencies were determined: heat transfer coefficient ( $k$ ) and pipeline isolation thickness ( $s$ ), as well as heat conduction coefficient ( $kD_m$ ) and pipeline isolation thickness ( $s$ ), and their interdependencies were given in Table 2.

The values of the heat transfer coefficient ( $\alpha_a$ ) from the isolation of the main oil pipeline to the environment were determined using equation (2) for the isolation thickness ( $s$ ), 25 to 100 mm and those are given in Table 2.

**Table 2.** Dependence of heat transfer coefficient ( $k$ ) and isolation thickness ( $s$ )

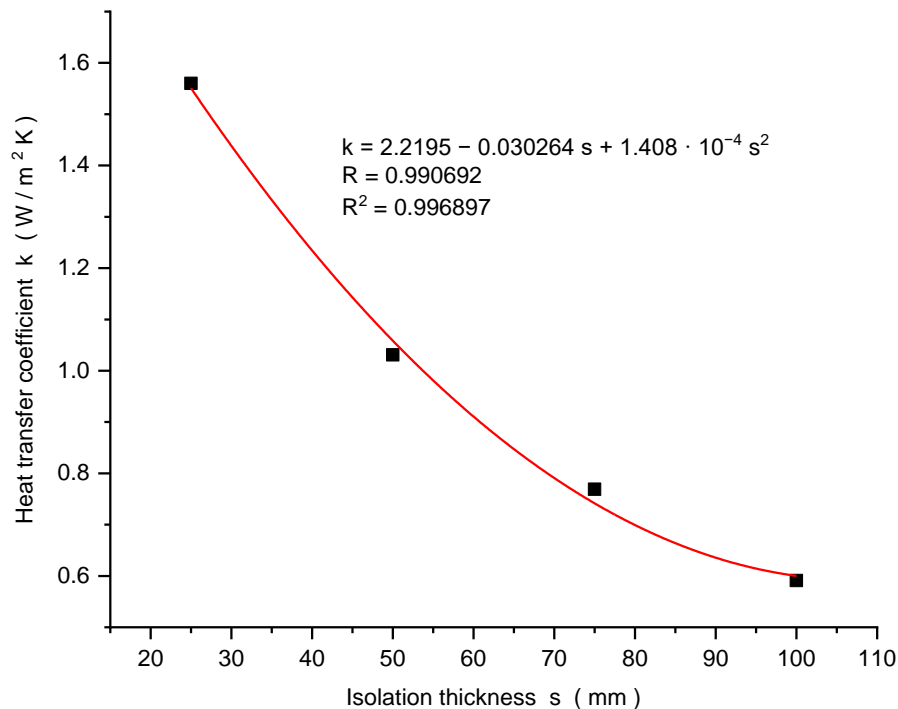
The parameters		Values			
1	Heat conduction coefficient $kD_m$ (W/mK)	0,320	0,387	0,493	0,706
2	Heat transfer coefficient $k$ (W/m <sup>2</sup> K)	0,591	0,769	1,031	1,560
3	Heat transfer coefficient from pipeline isolation to the environment $\alpha_a$ (W/m <sup>2</sup> K)	2,970	3,102	3,252	3,414
4	Isolation thickness $s$ (mm)	100	75	50	25

The dependence of the heat transfer coefficient ( $k$ ) on the isolation thickness ( $s$ ) for the main oil pipeline is given in Fig. 2. Numerical values of the heat transfer coefficient through the pipeline were determined using the known equation (1) according to [4], by varying the isolation thickness ( $s$ ) for values 25 – 100 mm and those are given in Table 2.

With a decrease in the thickness of the pipeline isolation, there is an increase in the heat transfer coefficient and heat losses. During transport, the oil cools and transfers its heat to the environment.

This is the heat flow between the system (pipeline) and the environment (surrounding soil). The initial temperature of the oil decreases in the direction of flow to the end of the pipeline. At the same time, the difference in oil temperature at the beginning and at the end of the pipeline increases.

At the beginning of pumping, heat losses are higher due to the fact that the environment is unheated. As the pumping time, ie. transport increases, heat losses are reduced, because of the soil heating around the pipeline and the reduction of the temperature difference between the pipeline and the environment.

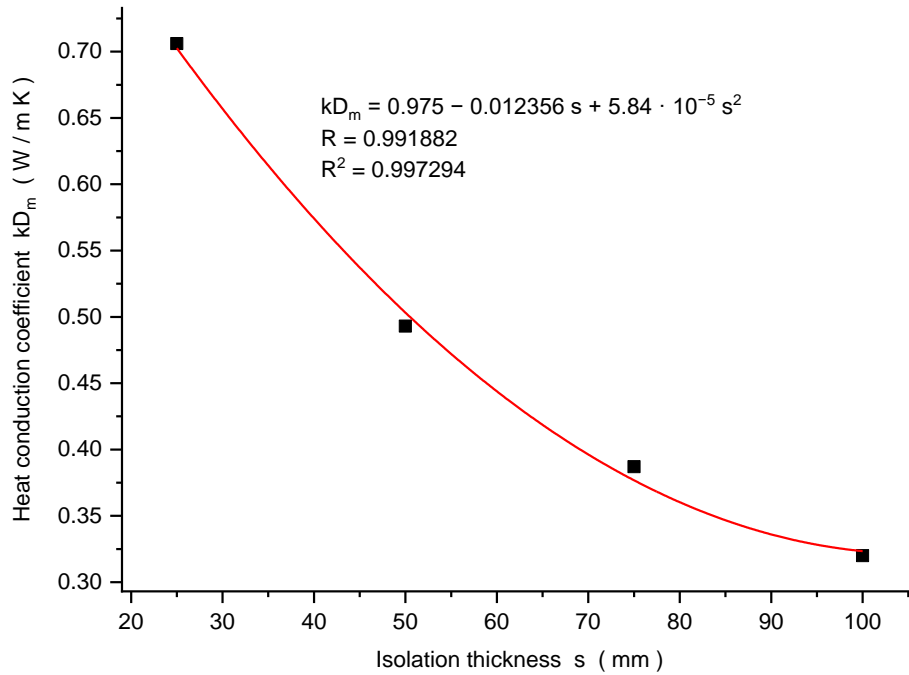


**Fig. 2.** Dependence of heat transfer coefficient ( $k$ ) and isolation thickness ( $s$ )

Based on the statistical regression analysis of the given data, the following empirical formula was obtained:

$$\begin{aligned} k &= 2.2195 - 0.030264 s + 1.408 \cdot 10^{-4} s^2 \\ R &= 0.990692 \\ R^2 &= 0.996897 \end{aligned} \quad (4)$$

The dependence of the heat conduction coefficient ( $kD_m$ ) and the isolation thickness ( $s$ ) is shown in Fig. 3. When there is a heat exchange between two fluids that are separated by a wall, this type of heat exchange is called heat transfer. The heat transfer coefficient depends on several influential parameters such as: pipeline diameter, pipeline wall thickness, isolation thickness, convective characteristic, etc. [1].



**Fig. 3.** Dependence of heat conduction coefficient ( $kD_m$ ) and isolation thickness ( $s$ )

Based on the statistical regression analysis of the given data, the following empirical formula was obtained:

$$\begin{aligned}
 kD_m &= 0.975 - 0.012356 s + 5.84 \cdot 10^{-5} s^2 \\
 R &= 0.991882 \\
 R^2 &= 0.997294
 \end{aligned}
 \tag{5}$$

The heat transfer coefficient through the pipeline has a dominant influence on the cooling rate of the oil in the pipeline. The thickness of the pipeline isolation has the greatest influence on the value of the heat transfer coefficient. Based on the research results, the values for the heat conduction coefficient ( $kD_m$ ) and the heat transfer coefficient ( $k$ ) were obtained, for the isolation thickness of the oil pipeline 25 – 100 mm.

For pipeline isolation thickness  $s = 100$  mm, the heat transfer coefficient is  $k = 0,591$  W/m<sup>2</sup>K, and the heat conduction coefficient is  $kD_m = 0,320$  W/mK, [10].

In the case of non-isolated pipeline, ie.  $s = 0$  mm, the heat transfer coefficient is  $k = 2,2195$  W/m<sup>2</sup>K, equation (4), and the heat conduction coefficient is  $kD_m = 0,975$  W/mK, equation (5), [10].

The results of experimental research of the heat transfer coefficient through the main oil pipeline, in the case of non-isothermal flow of crude oil, are in accordance with [3], [8].

According to the literature [3], [8], the heat transfer coefficient of an isolated oil pipeline is in the range  $k = 0,58 - 1,38$  W/m<sup>2</sup>K. For non-isolated pipeline protected by anti-corrosion insulating tape, the heat transfer coefficient is  $k = 1,75 - 2,5$  W/m<sup>2</sup>K.

According to the literature [4], [9], the heat conduction coefficient of an isolated oil pipeline with a diameter of 400 mm is  $kD_m = 0,520 - 0,650$  W/mK.

By reducing the isolation thickness, the heat transfer coefficient, the heat conduction coefficient, as well as heat losses increase.

## CONCLUSION

The heat transfer coefficient through the main oil pipeline is  $k = 0,60$  W/m<sup>2</sup>K, with isolation thickness  $s = 100$  mm. If the pipeline were non-isolated, the heat transfer coefficient would be  $k = 2,20$  W/m<sup>2</sup>K, [11].

The heat conduction coefficient through the main oil pipeline is  $kD_m = 0,320$  W/mK, with isolation thickness  $s = 100$  mm. If the pipeline were non-isolated, the heat conduction coefficient would be  $kD_m = 0,975$  W/mK.

It can be concluded that all influential parameters that depend on the construction of the pipeline are constants for the main oil pipeline, except for the coefficient of heat transfer from the pipeline to the environment, ie. the coefficient of losses for the buried oil pipeline in the ground ( $\alpha_a$ ), and the coefficient of heat transfer from the transported crude oil to the pipeline ( $\alpha_i$ ).

When starting the oil flow through an unheated pipeline, the oil cools faster than the case of stationary flow in a heated pipeline. The given results of experimental research refer to stationary hydraulic and thermal transport conditions. When starting the pump, ie. at the beginning of pumping, heat losses are significantly higher than losses under stationary transport conditions. The values of the heat transfer coefficient ( $k$ ), as well as the heat conduction coefficient ( $kD_m$ ) have a significant impact on the amount of heat losses through the pipeline.

## REFERENCES

- [1] Sasic, M.: Transport of fluids and solid materials by pipes, Science book, Belgrade, 1990.
  - [2] Tanaskovic, P.: Transport of crude oil and gas Part II, Faculty of Mining and Geology, Belgrade, 1998.
  - [3] Prstojevic, B.: Cevovodni transport nafte i gasa, Rudarsko-geološki fakultet, Beograd, 2012.
  - [4] Sasic, M.: Calculation of fluid and solid materials transport by pipes, Science book, Belgrade, 1976.
  - [5] Holman, J.P.: Thermodynamics, Mc-Graw-Hill Book Comp., New York, 1980.
  - [6] Holman, J.P.: Heat Transfer, Mc-Graw-Hill Book Comp., New York, 1981.
  - [7] Lambić, M.: Termotehnika sa energetikom, Tehnički fakultet "Mihajlo Pupin", Zrenjanin, 1998.
  - [8] Sun, J., Jing, J., Wu, C., Xiaoa, F., Luo, X.: Pipeline transport of heavy crudes as stable foamy oil, Journal of Industrial and Engineering Chemistry 44, pp.126–135, 2016.
  - [9] Sorin, N., Cornel, T., Albulescu, M., et. al.: Numerical model of crude oil non-isotherm transport through pipelines, Revista de Chimie, Vol. 58, Issue: 10, pp. 992-995 Published: Oct. 2007.
  - [10] Tolmac, J.: Optimization of thermal and hydraulic parameters of crude oil pipeline transport, Ph.D. Thesis, University of Novi Sad, Technical faculty "Mihajlo Pupin", Zrenjanin, 2020.
  - [11] Tolmac, J., Prvulovic, S., Nedic, M., Tolmac D.: Analysis of the main parameters of crude oil pipeline transport, Chemical Industry, Vol. 74, No. 2, pp. 79-90, 2020. ISSN 2217-7426.
-

## LABORATORY TESTING, EVALUATION AND ANALYSIS OF PORTLAND CEMENT IN OIL AND GAS WELLS

Milan Marković<sup>1</sup>, Saša Jovanović<sup>1</sup>, Jasna Tolmač<sup>1</sup>, Isidora Popov<sup>1</sup>

<sup>1</sup>University of Novi Sad, Technical Faculty "Mihajlo Pupin", Zrenjanin, Serbia

e-mail: [milanzmarkovic@gmail.com](mailto:milanzmarkovic@gmail.com)

**Abstract:** Cementing is an integral, necessary aspect of drilling oil and gas wells. Cement is used to secure casing strings and to isolate zones for production purposes as well as to solve various hole problems. A properly planned cement program is essential to a successfully drilled well. Laboratory testing of cements and cementing materials is an essential part of the entire cementing process. Testing begins at the manufacturing sites of the cement and additives to monitor product quality, and it continues through the slurry design stages at the pumping service company or operating company laboratories as a specific formulation is developed. The API Committee on Standardization of Well Cements (Committee 10) acts as a governing body regarding the development of standardized test procedures for the performance evaluation of well cement slurries. Consequently, most oil companies and service companies, and many instrument manufacturers, are engaged in research to improve existing techniques or to invent new procedures and equipment which simulate downhole conditions more accurately.

**Key words:** cementing, drilling, oil, gas, wells, cement, laboratory, testing, cementing materials, additives, API

### INTRODUCTION

Cementing is an integral, necessary aspect of drilling oil and gas wells. Cement is used to secure casing strings and to isolate zones for production purposes as well as to solve various hole problems. A properly planned cement program is essential to a successfully drilled well [1].

Cement planning consists of several features, including the following:

- assessment of hole conditions such as temperature, size, etc.
- evaluation of mud properties
- slurry design
- placement techniques
- equipment selection, such as centralizers, scratchers, and float equipment

Lack of attention to any of these items may cause problems with the cement job and necessitate other efforts.

### MATERIAL AND METHODS

Laboratory testing of cements and cementing materials is an essential part of the entire cementing process. Testing begins at the manufacturing sites of the cement and additives to monitor product quality, and it continues through the slurry design stages at the pumping service company or operating company laboratories as a specific formulation is developed. Evaluation is frequently conducted on samples obtained from the bulk plant as the blend is prepared, and on samples taken from storage silos as the material is placed on location. Field blend samples of both the dry-blended cements and the wet slurry can be obtained during mixing for subsequent evaluation, either in the laboratory or on location using portable laboratory equipment. Laboratory examination of samples obtained from the field can sometimes be used as an aid in post treatment investigations.

In general, there are two types of laboratory testing of cements and cementing materials: performance evaluation and chemical characterization. The typical oilfield laboratory is engaged primarily in the performance evaluation of cements, through physical measurement of specific slurry properties under simulated downhole conditions. This type of evaluation is used mainly in the slurry design stages of a cementing treatment, and in the execution stages to monitor the preparation of the blended material. Chemical characterization typically involves quantitative or qualitative analysis of the slurry components prior to mixing, to ensure their suitability for use. Analytical techniques are used for quality-control purposes at the point of manufacture, to determine that components of a dry-blended

cement system are present in the desired quantities, and are blended sufficiently at the bulk plant. Such techniques are also used to monitor the quality of the mix water on location. Correct application of a wide variety of laboratory testing methods is necessary to achieve a successful cementing treatment. This appendix presents a broad overview of laboratory testing procedures and equipment, and is not proposed as a manual for cement laboratory workers [2].

### Chemistry and Characterization of Portland Cement

Portland cement is by far the most important binding material in terms of quantity produced, indeed, it is possible that it may be the most ubiquitous manufactured material. Portland cement is used in nearly all well cementing operations. The conditions to which Portland cements are exposed in a well differ significantly from those encountered at ambient conditions during construction operations: as a result, special Portland cements are manufactured for use as well cements. Certain other cements, used to a far lesser extent for the solution of special well problems. Portland cement is the most common example of a hydraulic cement. Such cements set and develop compressive strength as a result of hydration, which involves chemical reactions between water and the compounds present in the cement, not upon a drying-out process. The setting and hardening occur not only if the cement/water mixture is left to stand in air, but also if it is placed in water. The development of strength is predictable, uniform and relatively rapid. The set cement also has low permeability, and is nearly insoluble in water, therefore, exposure to water does not destroy the hardened material. Such attributes are essential for a cement to achieve and maintain zonal isolation. [3]

The chemical formulas of many cement compounds can be expressed as a sum of oxides, for example, tricalcium silicate,  $Ca_3SiO_5$ , can be written as  $3CaO * SiO_2$ . Abbreviations are given for the oxides most frequently encountered, such as *C* for  $CaO$  and *S* for  $SiO_2$ . Thus  $Ca_3SiO_5$  becomes  $C_3S$ . A list of abbreviations is given below.

$C = CaO$	$A = Al_2O_3$	$S = SiO_2$	$F = Fe_2O_3$	$M = MgO$	$H = H_2O$
$N = Na_2O$	$K = K_2O$	$L = Li_2O$	$P = P_2O_5$	$f = F_2O$	$T = TiO_2$

### Cement Additives and Mechanisms of Action

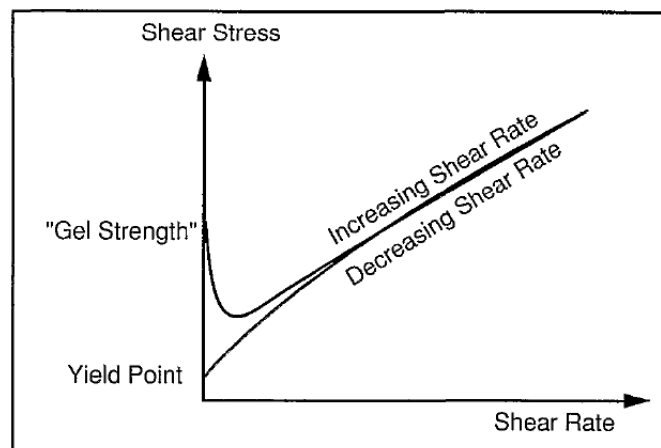
In well cementing, Portland cement systems are routinely designed for temperatures ranging from below freezing in permafrost zones to 700°F (350°C) in thermal recovery and geothermal wells. Well cements encounter the pressure range from near ambient in shallow wells to more than 30,000 psi (200 MPa) in deep wells. In addition to severe temperatures and pressures, well cements must often be designed to contend with weak or porous formations, corrosive fluids, and over pressured formation fluids. It has been possible to accommodate such a wide range of conditions only through the development of cement additives. Additives modify the behavior of the cement system, ideally allowing successful slurry placement between the casing and the formation, rapid compressive strength development, and adequate zonal isolation during the lifetime of the well. Today, over 100 additives for well cements are available, many of which can be supplied in solid or liquid forms. Eight categories of additives are generally recognized: [4]

1. *Accelerators*: chemicals which reduce the setting time of a cement system, and increase the rate of compressive strength development.
2. *Retarders*: chemicals which extend the setting time of a cement system.
3. *Extenders*: materials which lower the density of a cement system, and/or reduce the quantity of cement per unit volume of set product.
4. *Weighting Agents*: materials which increase the density of a cement system.
5. *Dispersants*: chemicals which reduce the viscosity of a cement slurry.
6. *Fluid-Loss Control Agents*: materials which control the loss of the aqueous phase of a cement system to the formation.
7. *Lost Circulation Control Agents*: materials which control the loss of cement slurry to weak or vugular formations.
8. *Specialty Additives*: miscellaneous additives, e.g., antifoam agents, fibers, etc.



## Thixotropic Cements

Thixotropy is a term used to describe the property exhibited by a system that is fluid under shear, but develops a gel structure and becomes self-supporting when at rest (Shaw, 1970). In practical terms, thixotropic cement slurries are thin and fluid during mixing and displacement, but rapidly form a rigid self-supporting gel structure when pumping ceases. Upon reagitiation, the gel structure breaks and the slurry returns to a fluid and pumpable. Then, upon cessation of shear, the gel structure reappears and the slurry returns to a self-supporting state. This type of rheological behavior is continuously reversible with truly thixotropic cements. Consequently, their behavior is defined by a yield value ( $\tau_y$ ) and a plastic viscosity ( $\mu_p$ ) (Clement, 1979). The  $\tau_y$  is a theoretical value concerning the behavior of a fluid under conditions of shear. With thixotropic slurries, the  $\tau_y$  would be the shear stress necessary to initiate movement, i.e., measured at zero shear rate. For a nonthixotropic fluid, the yield value remains the same whether the shear rate is increasing or decreasing. There is no change in the physical structure of the fluid during the static period, and the pressure needed to put the fluid in movement does not change with time. In the case of a thixotropic fluid, the yield point is exhibited only upon the withdrawal of shear stress. If there is a lapse of time, a greater force than that indicated by the yield point will be required to put the fluid back into motion, as indicated in Figs. 1, 2, and 3. The difference between the “gel strength” and the yield point gives a measure of the “degree of thixotropy” of the fluid. Thixotropic cement systems have several important applications. They are often used in wells where excessive fallback of the cement column is a common occurrence (Wieland et al., 1969). Such wells have weak zones which fracture under low hydrostatic pressure. Self-supporting cements reduce the hydrostatic pressure to the formation as gel strength increases, and fallback is prevented [5].



**Fig. 1.** Generalized rheological behavior of thixotropic fluids [5]

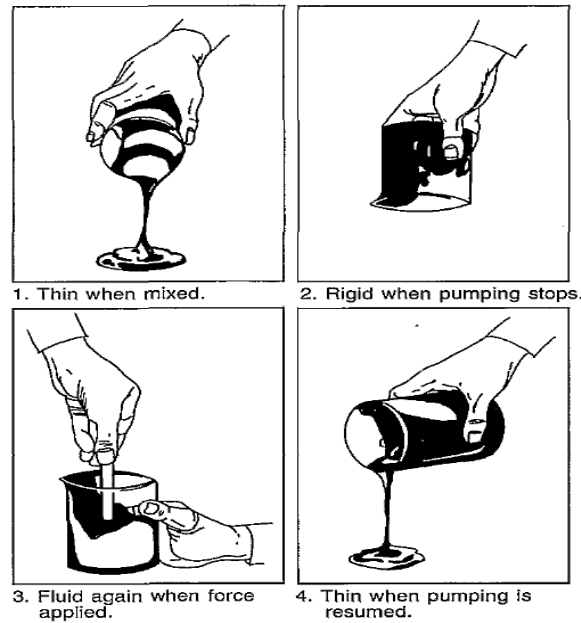


Fig. 2. Thixotropic behavior [5]

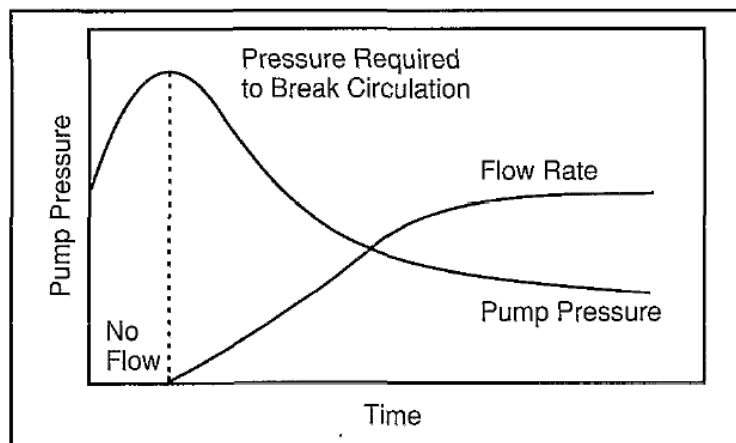


Fig. 3. Pump pressure and flow rate for a thixotropic fluid [5]

### High-Temperature Chemistry of Portland Cement

Portland cement is essentially a calcium silicate material, the most abundant components being tricalcium silicate ( $C_3S$ ) and dicalcium silicate ( $C_2S$ ). Upon addition of water, both hydrate to form a gelatinous calcium silicate hydrate called “C-S-H gel,” which is responsible for the strength and dimensional stability of the set cement at ordinary temperatures. In addition to C-S-H gel, a substantial amount of calcium hydroxide ( $CH$ ) is liberated. C-S-H gel is the early hydration product even at elevated temperature and pressure, and is an excellent binding material at well temperatures less than about 230°F (110°C). At higher temperatures, C-S-H gel is subject to increased shrinkage, which usually results in decreased compressive strength and increased permeability of the set cement. This phenomenon, known as “strength retrogression,” was first reported in the petroleum literature by Swayze (1954) as a result of the growing trend toward deep well completions. C-S-H gel often converts to a phase called “alpha dicalcium silicate hydrate ( $\alpha - C_2SH$ ).”  $\alpha - C_2SH$  is highly crystalline and much more dense than C-S-H gel. As a result, a shrinkage occurs which is deleterious to the integrity of the set cement. This effect is illustrated in Fig. 4,[6].

which depicts the compressive strength and water permeability behavior of conventional Portland cement systems cured at 446°F (230°C). Significant loss of compressive strength occurred within one month; however, the levels to which strength falls are sufficient to support casing in a well. The real problem lies in the severe permeability increases.

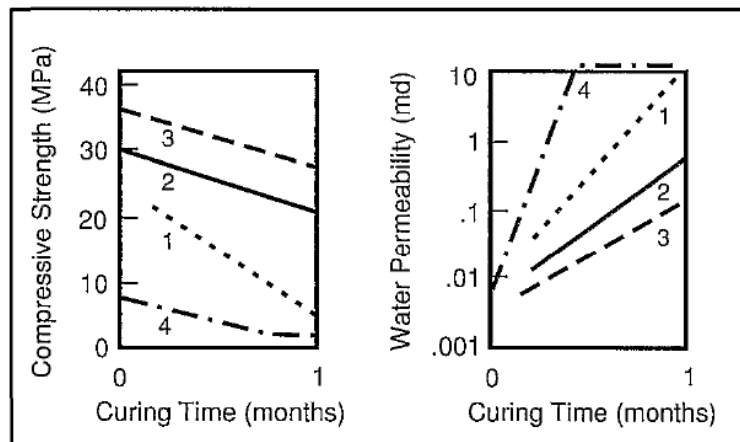


Fig. 4. Compressive strength and permeability behavior of neat Portland cement systems at 230°C (from Nelson and Eilers, 1985) [6]

### Deep Oil and Gas Wells

Wells with depths exceeding 15,000 ft (4,570 m), with bottomhole temperatures above 230°F (110°C), are common throughout the world. In recent years, several wells with depths exceeding 25,000 ft (7,600 m) have been completed. Such wells represent a large investment of time and money; therefore, obtaining a successful well completion is of paramount importance. The procedures for cementing deep wells are basically the same as those for shallower wells; however, such wells are generally considered critical, because of the more severe well conditions and higher complexity of the casing program. Higher temperatures, narrower annuli, overpressured zones, and corrosive fluids are commonly encountered. Consequently, the cement system design can be complex, involving an elaborate array of retarders, fluid-loss additives, dispersants, silica, and weighting materials. One must be certain that the cement system can be properly placed, and will maintain zonal isolation throughout the life of the well. Portland cement is used in virtually all deep oil and gas well completions [6].

### One – stage cementation

One – stage cementation – is the raising of the cement slurry to the planned height in the space between the protective pipes and the wall of the well in one operation, in the following order of procedures:[7]

- After installing the protective pipes in the well, the well channel is cleaned by rinsing, that is the clay lining (mud cake) is removed from the walls of the well with scrapers and centralizers, in order to achieve better contact between the cement and the well wall.
- On the cementation head, the first lower plug is released and a cement slurry is pressed which pushes that plug all the way to the impact plate where the plug stops. Then there is an increase in pressure that breaks through the membrane on the plug and the cement slurry passes through the plug, the impact plate, the heel of the column and enters the interspace.
- The second upper plug is released on the cementation head, which is pushed to the first plug with mud or water.
- The second plug cleans the inside of the protective pipes from the remaining cement slurry and when it lands on the first plug, it prevents further injection of mud inside the column. The increase in surface pressure means that the second plug has settled on the first, which also represents the end of one – stage cementation.

## RESULTS AND DISCUSSION

### Performance Evaluation of Conventional Cement Slurries

The API Committee on Standardization of Well Cements (Committee 10) acts as a governing body regarding the development of standardized test procedures for the performance evaluation of well cement slurries. The procedures are published by the American Petroleum Institute as API Spec 10. This publication contains specification tests for neat cement slurries, as well as operational testing procedures designed to encompass all conventional slurries. The procedures are designed to simulate downhole conditions for performance testing in a reasonably equipped field laboratory, and are based on a compromise between realistic wellbore conditions and the practical limitations of the laboratory environment.

### Fluid Loss

Fluid-loss tests are designed to measure the slurry dehydration during and immediately following the completion of the placement phase of a cementing treatment. Operational test procedures for the determination of the fluid-loss rate are contained in Appendix F of API Spec 10. After being subjected to simulated wellbore conditions in a consistometer, the test slurry is placed in a heated filter press cell, and the filtrate loss at either 100 psi or 1,000 psi differential pressure is measured across a standard filtration medium (325 mesh screen supported on a 60 mesh screen). The duration of the test is 30 minutes, and the filtrate volume ( $F_{30}$ ) is noted. If all of the filtrate passes through the screen in less than 30 minutes, the following equation is used to calculate a hypothetical  $F_{30}$ .

$$F_{30} = F_t * \frac{5.447}{\sqrt{t}} \quad (1) [2]$$

$F_t$  is equal to the volume of filtrate (ml) collected at time  $t$  (min). The prescribed test evaluates slurry fluid loss under static conditions (immediately following placement). No provision is made in this procedure for the measurement of fluid loss during placement, although results of fluid loss determinations under dynamic conditions have been reported.

### Free Water and Slurry Sedimentation

When a slurry is allowed to stand for a period of time prior to the set, water may separate from the slurry, migrate upward, and accumulate either in pockets or at the top of the column. This separation can result in incomplete zonal isolation, particularly in a highly deviated wellbore. The free-water test is designed to measure this separation tendency in the laboratory, using a 250 mL graduated cylinder as a simulated wellbore. The duration of the test is two hours. The operational procedure permits preparation of the slurry at elevated temperatures and pressures. As with other tests, no provision is made for fluid loss. As interest increases in cementing deviated wellbores, many operators are evaluating free-water development by orienting the graduated cylinder at the angle of deviation. Typically, an increase in free water is observed in these situations, however, there is no clear understanding regarding how free water depends upon column height. As with free-water development, when a slurry is allowed to stand for a period of time prior to development of a set, the suspended solids may tend to separate from the slurry and settle toward the bottom of the cement column. This separation is particularly evident in slurries containing weighting agents. Such "sedimentation" can produce a change in slurry density, leading to annular invasion and possible loss of well control. There is no published procedure specifically for the determination of the degree of settling in a cement slurry. Most field laboratories use the free-water tests, making a visual observation of any distinct settling which may be present. Settling can also be determined by sectioning a column of set cement, and comparing the density of the individual segments [2].

### Permeability

The permeability of the cement sheath is a vital parameter with regard to zonal isolation. An operational procedure for determining the water permeability of set cement is contained in API. The

---

apparatus and procedure were developed in the early 1950s. Water at a differential pressure of 20 to 200 psi (100 to 1,400 kPa) is forced through a sample of set cement. Water is flushed through the specimen for a maximum of 15 minutes, or until one milliliter has been accumulated in the measuring tube. Darcy's law (2) is used to calculate the permeability.

$$K = 14,700 * \frac{Q * \mu * L}{A * P} \quad (2) [2]$$

K – Permeability (mD)

Q – Flow rate  $\left(\frac{ml}{s}\right)$

$\mu$  – Water viscosity (cp)

L – Sample length (cm)

A – Sample cross-sectional area ( $cm^2$ ) and

P – Differential pressure (psi)

### Performance Evaluation of Spacers and Chemical Washes

To accomplish these objectives, the spacer and wash must impart some degree of cleaning effect in the wellbore, and must be compatible with the drilling fluid being displaced from the hole and with the cement slurry being placed in the hole. Laboratory testing of these materials must include procedures to evaluate the cleaning effect and the compatibility. The effects of a spacer or chemical wash upon the thickening time, compressive strength, fluid-loss control, and rheological characteristics of the cement system are investigated. The effects of the preflush upon the mud are also tested. Various volumetric ratios of mud, cement, and spacer are specified for the tests. No specific criteria are provided to aid in the interpretation of the test results. No such criteria appear to have been published, and the user must employ sound engineering judgment in evaluating and interpreting test results to determine fluid compatibility. Standard procedures to evaluate the mud removal capability of preflushes have not been published. A qualitative observation of the cleaning ability can be obtained by soaking a glazed tile in the drilling fluid, clamping the tile on the end of a rod, attaching the rod to a stirring motor, and rotating the tile in a container of the spacer/wash being evaluated for a period of time equal to the designed contact time of the spacer/wash across a specified section of the wellbore. Results of this observation may indicate a need to modify the spacer/wash formulation and/or the contact time [2].

### Cement Characterization and Analysis

Characterization of cement and cementing materials in the laboratory involves the application of appropriate analytical techniques to provide a chemical and/or physical description of the sample as a whole or of the chemical constituents of the sample. This physico-chemical identification may include a qualitative determination of the chemical species present, a quantitative measurement of the amount of one or more of these species present, and a determination of physical properties of one or more of these species or of the sample as a whole. Four types of samples typically are examined in an oilfield cementing laboratory: neat cement powder, dry-blended cement, set cement, and mix water. Occasionally, if a failure to obtain a set cement in the wellbore is suspected, a sample of fluid returned from the wellbore may be examined to determine the presence or absence of cementitious material. A wide variety of analytical techniques is available to characterize cement and cementing materials in the laboratory. Obtaining an accurate analysis of a sample may require the use of several of these techniques. An excellent review of techniques applicable to the chemical characterization of neat and dry-blended cements. Many techniques applicable to the physical characterization of these materials are contained in the ASTM Standards [2].

### Chemical Characterization of Portland Cement

Chemical analysis of Portland cement powder is typically performed to ascertain the relative amounts of the four principal phases present (tricalcium silicate, dicalcium silicate, tricalcium aluminate, and

tetracalcium aluminoferrite), gypsum, and certain minor oxides. X-ray diffraction (XRD) is commonly used in the laboratory to determine the phases qualitatively, although reliable quantitative analyses are possible only with careful attention to sample preparation and the use of consistent standards. A more accurate quantitative analysis of the principal cement phases is currently obtained by first performing a complete chemical analysis. Wet chemical methods, or atomic excitation spectroscopic methods such as atomic absorption (AA) or plasma emission (ICP/DCP), and X-ray fluorescence (XRF), are normally used. The oxide composition of the cement is calculated, and finally the “potential phase composition” is calculated using a system of equations developed by Bogue (1939). Bogue’s method is based upon various equilibrium relationships between the clinker phases. Taylor (1989) recently proposed a modification of the Bogue equations to more closely reflect current cement manufacturing practice. Selective chemical extraction and complexometric techniques have also been used for the separation and subsequent determination of individual phases. Some of these techniques can be applied specifically to determine the reactive phases (those located on the surface of the cement particle). Specific identification of surface phases can also be performed using scanning electron microscopy (SEM) and light microscopy. As with XRD, considerable operator skill is required for accurate quantitative analysis. In addition, it is difficult to assure that one is looking at a representative sample of the material. Thermal methods such as thermogravimetric analysis (TGA) and differential thermal analysis (DTA) can be used to determine gypsum, hemihydrate, and free lime in neat cement [2].

## **CONCLUSION**

The technology currently available for the testing of well cements is sophisticated, however, there is much room for improvement. Consequently, most oil companies and service companies, and many instrument manufacturers, are engaged in research to improve existing techniques or to invent new procedures and equipment which simulate downhole conditions more accurately. Many methods or devices exist as “in-house” technology, where use is often limited to the company where the invention was made. Some of these are gaining acceptance throughout the industry, and may eventually appear as standard API tests.

## **REFERENCES**

- [1] Neal, J. Adams, Charrier, T.: *Drilling Engineering - A Complete Well Planning Approach*, Penn Well Books, Penn Well Publishing Company, Tulsa, Oklahoma, pp.290-300, 1985.
- [2] Bell, D., Nelson, E.: *Laboratory Testing, Evaluation, and Analysis of Well Cements*, Schlumberger Dowell, Sugar Land, Texas, pp. 1–16, 1990.
- [3] Michaux, M., Nelson, E., Vidick, B.: *Chemistry and Characterization of Portland Cement*, Schlumberger Dowell, Sugar Land, Texas, pp.1–17, 1990.
- [4] Nelson, E., Baret, J-F., Michaux, M.: *Cement Additives and Mechanisms of Action*, Schlumberger Dowell, Sugar Land, Texas, pp. 1–37, 1990.
- [5] Nelson, E., Drecq, P.: *Special Cement Systems*, Schlumberger Dowell, Sugar Land, Texas, pp. 1–14, 1990.
- [6] Nelson, E.: *Thermal Cements*, Schlumberger Dowell, Sugar Land, Texas, pp. 1–19, 1990.
- [7] Bizjak, R.: *Tehnologija bušenja sa projektovanjem*, NIS-NAFTAGAS, Novi Sad, pp. 233–234, 2004.

Session 5:  
**Engineering Management**

## SELECTION OF CONSTRUCTION SITE MANAGER IN THE COMPANY "KRAFT PORT" DOO NOVI SAD: MULTICRITERIA APPROACH

**Branislav Kuzmanović<sup>1</sup>, Srdana Taboroši<sup>2</sup>, Jelena Rajković<sup>3</sup>,  
Siniša Mitić<sup>4</sup>, Milan Nikolić<sup>2</sup>**

<sup>1</sup>"KRAFT PORT" DOO Novi Sad, Novi Sad, Serbia

<sup>2</sup> University of Novi Sad, Technical Faculty "Mihajlo Pupin", Zrenjanin, Serbia

<sup>3</sup> University "Union Nikola Tesla", Faculty of Engineering management, Belgrade, Serbia

<sup>4</sup> University of Novi Sad, Faculty of Technical Science, Novi Sad, Serbia

e-mail: [kraftportbk@gmail.com](mailto:kraftportbk@gmail.com)

**Abstract:** The paper presents the procedure for selecting a construction site manager in the company "KRAFT PORT" DOO Novi Sad. This company is engaged in performing construction work for high-rise buildings. The selection of the construction site manager was made between seven available candidates (seven actions, ie seven managers), based on seven criteria. The method of multicriteria analysis was used: The method of Hierarchical additive weights. It has been shown that numerous problems in management and business decision - making can be successfully solved through appropriate methods of multicriteria analysis.

**Key words:** Managerial selection, Multicriteria analysis, Hierarchical additive weight method.

### INTRODUCTION

Assessment and selection of employees is a very important activity for companies (Afshari, Nikolić, Akbari, 2017). Accordingly, one of the most important areas within human resource management is the selection of employees (staff). The selection of employees determines the input quality of employees, as a result of which it plays a crucial role in human resource management. Practically, the quality of employees is closely related to the selection of employees (Afshari, Nikolić, Čočkaló, 2014; Chien, Chen, 2008). When candidates apply for specific jobs in an organization, the primary purpose of the employee selection process is to identify those employees who have the necessary knowledge, skills, and abilities to successfully perform defined jobs and meet job needs (Kaynak, 2002). Different jobs require different abilities, so the set of criteria that measure those abilities is different as well (Afshari, Nikolić, Akbari, 2017).

To address the problem of employee selection, appropriate, flexible methods are needed to assess the performance of each candidate, in accordance with the different requirements of different jobs, and in relation to each criterion. One of the well-known decision-making methods is Multi-Criteria Decision Making (MCDM), which can be used in the employee selection process. As with many other decision-making problems, the problem of employee selection is very complex in real life. Multi-criteria decision making (MCDM) is widely used to solve decision-making problems that include a number of ranking criteria and selection of alternatives. The literature suggests different decision-making methods regarding the choice of human resources (Afshari, Nikolić, Akbari, 2017). Most researchers and practitioners apply the following methods: method of analytical hierarchical processes (AHP), then analytical network process (ANP), ranking technique based on similarity with ideal solutions (TOPSIS), phase set theory, methods of expert systems (ES), as well as various versions and subvariants of these methods (Afshari, Nikolić, Čočkaló, 2014).

The selection of employees is especially important when it comes to the selection of people for management positions. It is of great importance for companies to have appropriate people - managers, both in the position of top managers and in all management positions. By placing the best candidates for managerial positions, better business results are certainly achieved and the organization has a better chance of achieving the desired strategic positions. In the process of choosing a manager, the evaluation of managers also plays a significant role.

When selecting managers for certain management positions, it is sometimes necessary to perform a comprehensive analysis of individual candidates. As previously stated, this analysis requires the use of



a number of criteria, which is actually the basis for the application of different models of multi-criteria analysis in solving these business decision-making problems.

In this paper, the problem of choosing a construction site manager in the company "KRAFT PORT" DOO for construction, trade and services Novi Sad is observed. This company is engaged in performing construction work on high-rise buildings in the Autonomous Province of Vojvodina, but also beyond. Legal entity "KRAFT PORT" DOO for construction, trade and services Novi Sad, was founded on 19.10.2009. The address of the company is Novi Sad, Jevrejska 26. The legal entity has three employees, while contractors are hired for construction work. The company has continuous business growth. Also, KRAFT PORT DOO received positive references from satisfied apartment buyers.

The selection of the construction site manager was made between seven available candidates (seven actions, ie seven managers), based on seven criteria. The method of multicriteria analysis was used: The method of Hierarchical additive weights.

## METHOD OF HIERARCHY ADDITIVE WEIGHTS

The method of simple additive weights and the method of hierarchical additive weights are among the methods of multicriteria analysis, which are most often used. Their simplicity, practicality, clarity and concreteness of the obtained solutions contribute to this (Nikolić, 2012). According to (Afshari, Nikolić, Akbari, 2017), simple additive weighting (SAW) procedures are based on a weighted sample, and successfully overcome the imprecision and bias of models involving pairwise comparison.

The method of simple additive weights and the method of hierarchical additive weights imply a procedure in which the decision maker first forms the initial decision matrix. Then the necessary attribute transformations are performed (qualitative attributes are transformed into quantitative ones). Then some of the attribute transformation methods are applied. In this part, in fact, there are differences between the two methods.

In the method of simple additive weights, vector normalization is applied. This means that each element of the vector - the column from the decision matrix (within one criteria) is divided with its norm. The normalized value  $n_{ij}$ , the normalized decision matrix  $N$ , is obtained according to the formula:

$$n_{ij} = \frac{x_{ij}}{\sqrt{\sum_{i=1}^m x_{ij}^2}},$$

wherein:

$i = 1, 2, \dots, m$  – number of actions,

$j = 1, 2, \dots, n$  – number of attributes.

The following expression is used to transform minimization  $A_j$  to maximization  $A_j$ :

$$n_{ij} = 1 - \frac{x_{ij}}{\sqrt{\sum_{i=1}^m x_{ij}^2}}.$$

In the method of hierarchical additive terms, the transformation of attributes here takes place according to the formula:

$$p_{ij} = \begin{cases} x_{ij} / \sum_{i=1}^m x_{ij}, & \text{za max } A_j \\ 1 - \left( x_{ij} / \sum_{i=1}^m x_{ij} \right), & \text{za min } A_j \end{cases}$$

Practically, the transformation of attributes is done by dividing each value of an action by the sum of all values of actions according to the observed attribute. If there is a requirement for a minimum, then the value obtained is subtracted from 1.

When normalization is performed according to the selected procedure, the further procedure is again the same for both methods. The sum of the products of the transformed attribute values and the weight coefficients of the corresponding attributes is calculated. This is done for each action separately. This, mathematically, can be represented by the formula:

$$a^* = \left\{ a_i \mid \max \sum_{j=1}^n w_j \cdot n_{ij} / \sum_{j=1}^n w_j \right\}$$

wherein:

$n_{ij}$  - transformed attribute values (vector normalization or some other procedure),  
 $w_j$  - the weight of the  $j$ -th attribute (criteria).

Finally, the action with the largest sum of products (the action with the highest average weight) is selected.

## MULTICRITERIA RANKING OF MANAGERS IN THE OBSERVED CASE

### Defining actions and criteria

In the observed case (selection of the site manager), the actions are the managers themselves, who are competing for the position of executor of the site manager. Thus, the choice was made between the following seven managers:  $a_1$  - Manager 1,  $a_2$  - Manager 2,  $a_3$  - Manager 3,  $a_4$  - Manager 4,  $a_5$  - Manager 5,  $a_6$  - Manager 6,  $a_7$  - Manager 7.

Also, the following seven criteria (attributes) are defined:

- C1 - Expertise in the field of construction,
- C2 - Organizational skills,
- C3 - Communication skills,
- C4 - Ability to work with people,
- C5 - Ability to work in stressful situations,
- C6 - Ability to creatively solve problems,
- C7 - Experience in similar jobs.

### Defining the initial decision matrix

All managers were evaluated according to each of the above criteria. The assessment was performed with qualitative assessments, classified into five levels: Very High, High, Average, Low and Very Low. All criteria have a maximization requirement. Managers were evaluated in the manner shown in Table 1 (initial decision matrix).

**Table 1.** Initial decision matrix (qualitative attributes)

Actions (menagers)	Criteria						
	C1	C2	C3	C4	C5	C6	C7
	Request for max / min criteria						
	max	max	max	max	max	max	max
$a_1$	Very high	High	High	High	Low	High	Very high
$a_2$	Very high	High	Average	Average	Average	Average	Very high
$a_3$	High	Very high	Average	Low	Average	High	Average
$a_4$	High	High	Very high	High	High	Low	Average
$a_5$	High	Average	High	High	High	Very high	Low
$a_6$	Average	Average	Average	Very high	Very high	High	High
$a_7$	Average	Low	High	Very high	High	High	Very high

Since in the initial decision-making matrix all actions are evaluated with qualitative evaluations, it is necessary to transform these evaluations into quantitative ones, due to the possibility of further calculation. Quantification is performed over the interval scale, which is shown in Table 2. Since there is no problem of translating the minimum to the maximum, the last type of Table 2 is not used. Quantified estimates of all actions according to each criterion are given in Table 3.

**Table 2.** Scale interval for transforming qualitative attributes into quantitative ones

Qualitative assessment	Very low	Low	Average	High	Very high	Type of criteria
Quantitative assessment	1	3	5	7	9	max
	9	7	5	3	1	min

**Table 3.** Initial decision matrix (quantitative attributes)

Actions (menagers)	Criteria						
	C1	C2	C3	C4	C5	C6	C7
	Request for max / min criteria						
	max	max	max	max	max	max	max
a1	9	7	7	7	3	7	9
a2	9	7	5	5	5	5	9
a3	7	9	5	3	5	7	5
a4	7	7	9	7	7	3	5
a5	7	5	7	7	7	9	3
a6	5	5	5	9	9	7	7
a7	5	3	7	9	7	7	9

### Defining the weights of the criteria in the model

The weights of the criteria in the observed model are given in Table 4.

**Table 4.** Weights of criteria in the model

Criteria	C1	C2	C3	C4	C5	C6	C7
$w_j$	0,2	0,2	0,15	0,15	0,1	0,1	0,1

### Multicriteria ranking by the method of Hierarchical additive weights

In the first step, it is necessary to perform the attribute transformation. Quantitative attributes from the initial decision matrix are transformed (Table 3). Examples of transformations performed:

$$p_{11} = \frac{x_{11}}{\sum_{i=1}^m x_{i1}} = \frac{9}{9+9+7+7+7+5+5} = \frac{9}{49} = 0,1837;$$

$$p_{71} = \frac{x_{71}}{\sum_{i=1}^m x_{i1}} = \frac{5}{9+9+7+7+7+5+5} = \frac{5}{49} = 0,1020.$$

A table can now be formed containing all the transformed attribute values, for all criteria. These values are given in Table 5.

**Table 5.** Transformed attribute values for all criteria

Actions (menagers)	Criteria						
	C1	C2	C3	C4	C5	C6	C7
	Request for max / min criteria						
	max	max	max	max	max	max	max
a1	0,1837	0,1628	0,1556	0,1489	0,0698	0,1556	0,1915
a2	0,1837	0,1628	0,1111	0,1064	0,1163	0,1111	0,1915
a3	0,1429	0,2093	0,1111	0,0638	0,1163	0,1556	0,1064
a4	0,1429	0,1628	0,2000	0,1489	0,1628	0,0667	0,1064
a5	0,1429	0,1163	0,1556	0,1489	0,1628	0,2000	0,0638
a6	0,1020	0,1163	0,1111	0,1915	0,2093	0,1556	0,1489
a7	0,1020	0,0698	0,1556	0,1915	0,1628	0,1556	0,1915
w <sub>j</sub>	0,2	0,2	0,15	0,15	0,1	0,1	0,1

Each column from Table 5 is multiplied by the corresponding weight of the criterion (the values from the column related to the observed criterion are multiplied by the weight of that criterion). This is how Table 6 was obtained.

**Table 6.** Transformed attribute values multiplied by the weight of the corresponding criterion

Actions (menagers)	Criteria						
	C1	C2	C3	C4	C5	C6	C7
	Request for max / min criteria						
	max	max	max	max	max	max	max
a1	0,03674	0,03256	0,02334	0,022335	0,00698	0,01556	0,01915
a2	0,03674	0,03256	0,01666	0,01596	0,01163	0,01111	0,01915
a3	0,02858	0,04186	0,01666	0,00957	0,01163	0,01556	0,01064
a4	0,02858	0,03256	0,03000	0,022335	0,01628	0,00667	0,01064
a5	0,02858	0,02326	0,02334	0,022335	0,01628	0,02000	0,00638
a6	0,0204	0,02326	0,01666	0,028725	0,02093	0,01556	0,01489
a7	0,0204	0,01396	0,02334	0,028725	0,01628	0,01556	0,01915
w <sub>j</sub>	0,2	0,2	0,15	0,15	0,1	0,1	0,1

In the next step, the values by types for each action are summed and the overall score of each action is obtained. Ranking is done based on the size of the final score for each action. This procedure and results are shown in Table 7. The next-to-last column of Table 7 shows the total ratings for each action, and in accordance with the size of these ratings, the ranks of actions are determined (the last column of Table 7).

**Table 7.** Final ranking of actions according to the method of Hierarchical additive weights

Actions	Values of actions	Ratings of actions
a1	0,1567	1
a2	0,1438	3
a3	0,1345	7
a4	0,1471	2
a5	0,1402	5
a6	0,1404	4
a7	0,1374	6

## CONCLUSION

In this paper, the problem of choosing a construction site manager is examined. In general, the issue of choosing a manager is very important and does not lose its relevance: in all areas of work and all circumstances and opportunities, it is very important and useful to have the right people in managerial positions. Undoubtedly, this greatly affects the final business results and success of individual business functions, as well as the organization as a whole.

In the observed case, the selection was made on the basis of a number of criteria, so a multicriteria analysis was used, that is, the method of Hierarchical additive weights. The results show that action a1 has the best result and it is certainly the most favorable option in the analyzed case. Therefore, for the position of manager on the construction site, action a1 - Manager 1 should be chosen.

The second place is taken by the action a4, and the third place is taken by the action a2. Practically, if Manager 1, for some reason, is unable to accept the job, then that task should be entrusted to Manager 4 or Manager 2. Other actions are significantly weaker compared to these three listed.

It has been shown once again that numerous problems in management and business decision - making can be successfully solved through appropriate methods of multicriteria analysis. The recommendation for company leaders and managers is to, to the maximum extent possible, whenever possible, use quantitative methods when planning and making decisions. This, above all, contributes to a better perception of the problem, but also to a more objective solution to that problem. At the same time, we should not forget that, after all, a person makes a decision, not a method. So, methods help in making decisions, but the responsibility is still on the person, who cannot justify his bad assessments and decisions through the method.

## REFERENCES

- [1] Afshari, A.R., Nikolić, M., Čočkaló, D., (2014). Applications of fuzzy decision making for personnel selection problem - a review. *Journal of Engineering Management and Competitiveness (JEMC)*, 4(2), 68-77.
- [2] Afshari, A.R., Nikolić, M., Akbari, Z., (2017). Personnel selection using group fuzzy AHP and SAW methods. *Journal of Engineering Management and Competitiveness (JEMC)*, 7(1), 3-10.
- [3] Chien, C.F., Chen, L.F. (2008). Data mining to improve personnel selection and enhance human capital: A case study in high-technology industry. *Expert Systems with Applications*, 34(1), 280-290.
- [4] Kaynak, T. (2002). *Human Resources Management*. Istanbul: Nobel Yayınevi.
- [5] Nikolić, M. (2012). *Decision methods 2nd edition*. Zrenjanin: Technical faculty "Mihajlo Pupin". (in Serbian)

## INTERNAL COMMUNICATION IN THE COMPANY "KRAFT PORT" DOO NOVI SAD

**Branislav Kuzmanović<sup>1</sup>, Jelena Rajković<sup>2</sup>, Srđana Taboroš<sup>3</sup>, Siniša Mitić<sup>4</sup>, Milan Nikolić<sup>3</sup>**

<sup>1</sup>"KRAFT PORT" DOO Novi Sad, Novi Sad, Serbia

<sup>2</sup>University "Union Nikola Tesla", Faculty of Engineering management, Belgrade, Serbia

<sup>3</sup>University of Novi Sad, Technical Faculty "Mihajlo Pupin", Zrenjanin, Serbia

<sup>4</sup>University of Novi Sad, Faculty of Technical Science, Novi Sad, Serbia

e-mail: [kraftportbk@gmail.com](mailto:kraftportbk@gmail.com), [j.rajkovic24@gmail.com](mailto:j.rajkovic24@gmail.com), [srdana.taborosi@gmail.com](mailto:srdana.taborosi@gmail.com),  
[smitic@uns.ac.rs](mailto:smitic@uns.ac.rs), [mikaczr@sbb.rs](mailto:mikaczr@sbb.rs)

**Abstract:** In this paper, the state of the internal communication item in the company for construction, trade and services "KRAFT PORT" DOO Novi Sad is examined. In addition, the condition of the observed items was examined depending on the age of the respondents and the level of education of the respondents in the company (high school or higher education). Respondents are employed in the observed company. The results show that the internal communication in the company "KRAFT PORT" DOO is very favorable and at a high level. Older employees, as well as employees with higher and higher education, more favorably assess the overall importance of communication in the company and the quality of information exchange in the company. Accordingly, the proposal is to strengthen vertical communication with younger employees and employees with high school.

**Keywords:** Manager selection, Multicriteria analysis, Hierarchical additive weight method.

### INTRODUCTION

Good internal communication in organizations is the basis of good relations in organizations. This further creates a positive atmosphere and energy in organizations, and then the enthusiasm, creativity, motivation and loyalty of employees (Nikolić, 2012). The employees themselves are the best representatives of their organizations in the external public, they transmit information and rumors from the organization to the external public by talking to their friends, family members and others. This is another reason for employees to be satisfied with the communication in their organization and to participate in creating a positive image of the organization in public (Nikolić, 2012).

Effective communication has a positive relationship with the degree of productivity and the degree of employee motivation (Robbins, Judge, 2009; Sprague, Del Brocco, 2002). Communication in organizations has an impact on strategic aspects of business (Anderson, 2001; Nelson, Coxhead, 1997; Nikolić, Terek, Vukonjanski, Ivin, 2012) and economic aspects of business (Andersen, Segars, 2001; Ehling, White, Grunig 1992; Yates, 2006). Also, effective organizational communication has a positive effect on organizational learning, proactivity, and innovation (Garcia-Morales, Matias-Reche, Verdu-Jover, 2011), as well as employee job satisfaction (Burke, Wilcox, 1969; Pincus, Knipp, Rayfield, 1990). . In general, the lack of effective and efficient communication is one of the biggest obstacles to achieving successful group performance (Robbins, Judge, 2009).

In this paper, the state of the internal communication item in the company "KRAFT PORT" DOO for construction, trade and services Novi Sad is examined. The activity of this legal entity is the construction of residential and non-residential buildings (activity code 4120). The company "KRAFT PORT" DOO for construction, trade and services Novi Sad, in its financial statements, has continuous business growth. Also, KRAFT PORT DOO received positive references from satisfied apartment buyers.

Also, the condition of the observed items was examined depending on the age of the respondents and the level of education of the respondents in the company (high school or higher education). The gender of the respondents is not considered in the research because men are the vast majority in this company, so valid data cannot be obtained according to this criterion. Based on that, possible directions of top management actions will be determined, in order to improve certain items of internal communication.

It is important to point out that internal communication is of great importance in companies engaged in construction, because work in construction requires a high degree of coordination of business and operational activities, fast, quality and timely exchange of information and feedback. From this follows the importance of studying the quality of internal communications in the observed company.

## **THEORY AND HYPOTHESIS**

Communication is the process of conveying messages between people. In this case, communication is realized only if the message reaches the recipient. Effective communication exists only if the recipient understood the message and made it known to the sender (Petković, Jovanović, 2002). Similarly, Ivancevich and Matteson (2002) define communication as the transition of information from one person or group to another, through the use of common (understandable) symbols, which can be verbal and nonverbal. In doing so, effective communication arises as a result of mutual understanding between the sender and recipient of the message (Ivancevich, Matteson, 2002).

Communication must exist in each group, that is, in each group there must be a transfer of meaning among the members of the group. In this way, ideas and information are transmitted from one person to another. In addition, the comprehensibility of the messages is important. Thus, communication implies both transmission and understanding of meaning. For example, no matter how good an idea is, it will have no meaning or benefit if it is not passed on to others and until other people understand it (Robbins, Judge, 2009).

In order for organizations to successfully perform their activities, it is necessary for employees to establish internal relations among themselves (Đorđević, Bešić, 2005). Communication in organizations is an exchange of information and ideas within organizations, and this is necessary for the successful implementation of all business activities (Nikolic, 2012). Communication with employees ensures the involvement of employees in all walks of life and functioning of the organization, which creates conditions for the emergence of a positive climate in the company and achieving better business results (Djordjevic, Besic, 2005). It is extremely difficult to find any aspect of managerial work that does not involve communication. Practically, every manager is a communicator (Ivancevich, Matteson, 2002).

Within groups and organizations, communication has four basic functions (roles): controlling, motivating, emotionally expressing, and informing (Robbins, Judge, 2009). These roles (functions) of communication are equally important. Each communication can simultaneously perform several of these roles in organizations. The importance of communication within the organization is growing on a global level, so organizations around the world are paying more and more attention to internal communication (Nikolić, 2012). Internal communication must be systematically planned and implemented, which reduces the level of errors in communication within the organization (Đorđević, Bešić, 2005).

The basic hypothesis in this paper is:

H0: Items of internal communication have high (favorable) values, in the company "KRAFT PORT" DOO for construction, trade and services Novi Sad.

In addition, the research has the following special hypotheses:

H1: Older employees perceive internal communication items as more favorable than younger employees, in the observed company.

H2: Employees with higher and higher education perceive internal communication items as more favorable than employees with high school, in the observed company.

### 3. METHOD

*Survey instruments (measures).* Internal communication was measured through The Communication Satisfaction Questionnaire (CSQ). This questionnaire was originally developed in the paper (Downs, Hazen, 1977). The questionnaire consists of 36 questions (items), which are classified into 7 dimensions. In this study, respondents rated each item with one of the scores from the interval 1-7, which means that a seven-point Likert scale was used..

*Participants and data collection.* The research was conducted by filling out a questionnaire by the respondents. Respondents are employed in the company "KRAFT PORT" DOO for construction, trade and services Novi Sad. The answers of 40 respondents from the observed company were collected. There are 15 respondents in the sample who are 40 or younger (younger respondents) and 25 respondents who are 41 or older (older respondents). The sample includes 22 respondents who have completed high school and 18 respondents who have higher or tertiary education.

### RESULTS

At the beginning, it is necessary to define the items of internal communication, which are examined in this paper. These are the items (questions) from the questionnaire, which is a research instrument - The Communication Satisfaction Questionnaire (CSQ) (Downs, Hazen, 1977). The questions are as follows:

- P1. Employee reward information is public.
- P2. There is information that is only available to selected members of the company.
- P3. Communication with other employees in my department is precise and free.
- P4. Information regarding the requirements of my job is accurate and complete (work assignments are clearly presented).
- P5. Written instructions and reports are clear and concise.
- P6. The director is ready to listen to me if I have any objections.
- P7. The director is ready to offer a solution to the problems in my business.
- P8. In case of urgency, the necessary information is transmitted quickly.
- P9. The information needed for my job arrives on time.
- P10. Communication between departments is active (necessary information is exchanged).
- P11. Information regarding the goals and policies of the company is complete and timely.
- P12. Attitudes regarding communication in the company are basically correct (great importance is attached to the exchange of information).
- P13. Information regarding the policy and goals of the department is comprehensive.
- P14. Meetings are well organized, with a clear goal and short.
- P15. Information regarding the financial operations of the company is complete.
- P16. Personal news is communicated to colleagues (this maintains a "family atmosphere" among employees).
- P17. Rumors (gossip, gossip) are not present in the company.
- P18. Company publications are useful and interesting.
- P19. The amount of information in the company is appropriate.
- P20. Employees in my company have a sense of communication (good exchange of information).
- P21. Information on the successes and failures of the company is available to employees.
- P22. Conflicts between employees are resolved through the exchange of opinions.
- P23. Communication in the company helps me feel like an important part of it.
- P24. The information regarding the progress in my business is complete and timely.
- P25. Information regarding changes in the company is complete and timely.
- P26. Communication in the company has a motivating effect on achieving the company's goals.
- P27. The director is familiar with the problems that employees face and is ready to help solve them.
- P28. My engagement in the business has been noticed.
- P29. Information on the assessment of my work achievements is complete and timely.
- P30. The instructions I receive for solving possible problems in my work are useful and timely.
- P31. The information on the measures taken by the top management, which are reflected in the work of the company, is complete and timely.



- P32. Information on how my job is valued in relation to other employees is available to me.  
 P33. The director trusts me.  
 P34. The director supports me.  
 P35. My working group (team, shift) is well formed and the relations in it are good.  
 P36. The director is ready to accept new ideas.

The results of descriptive statistics (mean values) for the observed questions, for the whole sample, then according to the age of the respondents (younger / older) and the education of the respondents (medium / higher and higher) are given in Table 1.

**Table 1.** Mean values of questions for the whole sample, according to the age and education of the respondents

Questions (items)	Whole sample	Age of respondents		Education of respondents	
		Younger respondents (N <sub>ML</sub> = 15)	Older respondents (N <sub>ST</sub> = 25)	Medium school (N <sub>SS</sub> = 22)	Higher or higher education (N <sub>VO</sub> = 18)
P1	2,45	2,80	2,24	2,50	2,39
P2	5,27	5,53	5,12	5,23	5,33
P3	5,85	6,00	5,76	5,82	5,89
P4	6,15	5,87	6,32	5,95	6,39
P5	6,20	6,27	6,16	6,23	6,17
P6	5,38	5,47	5,32	5,27	5,50
P7	5,73	5,47	5,88	5,68	5,78
P8	5,98	5,80	6,08	5,86	6,11
P9	5,45	5,40	5,48	5,18	5,78
P10	5,88	5,80	5,92	5,82	5,94
P11	5,35	5,13	5,48	4,91	5,89
P12	5,75	5,40	5,96	5,55	6,00
P13	5,58	5,33	5,72	5,36	5,83
P14	5,23	4,73	5,52	4,95	5,56
P15	4,50	4,07	4,76	4,23	4,83
P16	5,23	5,27	5,20	5,05	5,44
P17	4,73	4,40	4,92	4,50	5,00
P18	4,68	4,60	4,72	4,45	4,94
P19	4,75	4,53	4,88	4,55	5,00
P20	5,23	5,07	5,32	4,95	5,56
P21	3,10	2,20	3,64	2,50	3,83
P22	5,20	5,07	5,28	5,05	5,39
P23	4,93	4,80	5,00	4,50	5,44
P24	4,85	4,53	5,04	4,73	5,00
P25	4,82	4,67	4,92	4,59	5,11
P26	5,47	5,33	5,56	5,27	5,72
P27	4,97	5,00	4,96	4,86	5,11
P28	5,10	4,93	5,20	4,86	5,39
P29	4,82	4,73	4,88	4,64	5,06
P30	5,35	4,87	5,64	5,18	5,56
P31	5,23	5,13	5,28	5,14	5,33
P32	5,12	5,07	5,16	4,95	5,33
P33	5,02	4,87	5,12	4,68	5,44
P34	4,92	4,73	5,04	4,68	5,22
P35	5,65	5,60	5,68	5,55	5,78
P36	4,90	4,80	4,96	4,64	5,22

## **DISCUSSION OF RESEARCH RESULTS**

### **The whole sample**

Internal communication items have relatively high (favorable) values in the observed company. The vast majority of mean values are above average (4 for a scale of 1 to 7). In this way, it can be stated that the basic hypothesis (H0) has been confirmed in this paper.

The items with the job description, instructions and information transfer in case of emergency are rated the best. This is quite understandable when it comes to the construction industry, where everything must be clearly and precisely explained. At the same time, this is very useful for the observed company because the height of these parameters indicates effective and efficient work.

The items related to transparency in remuneration and transparency in the general business of the company were rated the lowest. It is very likely that the top management of the company believes that employees should not have access to this information.

### **Younger and older respondents**

Older employees perceive the items of internal communication as more favorable than younger employees, in the observed company. In the vast majority of items, the mean values are higher for older employees. In this way, it can be stated that the first special hypothesis (H1) in this paper has been confirmed.

Information on company success, financial performance and advancement is more accessible to older employees than to younger employees. Also, older employees to a greater extent believe that the meetings are well organized, and the job instructions are useful and timely. Overall, older employees think that communication and information exchange in the company is of great importance, while younger employees recognize it to a lesser extent. Lack of information is probably the reason why younger employees are more concerned with rumors (gossip, gossip) than older employees.

On the other hand, younger employees to a greater extent believe that information on remuneration, but also some other information is available only to some members of the company. This is in line with the previous discussion where it was shown that older employees get more information. In addition, horizontal communication (among colleagues) seems to be somewhat better among younger employees. This may be because young people socialize more, talk to each other more, but also because in this way they compensate for the possible lack of information vertically.

### **Respondents with secondary and respondents with higher and higher education**

Employees with higher and higher education perceive the items of internal communication as more favorable than employees with high school, in the observed company. In the vast majority of items, the mean values are higher for employees with higher and higher education. In this way, it can be stated that the second special hypothesis (H2) in this paper has been confirmed.

Similar to older employees, employees with higher and higher education have more information about the success of the company, the goals and business policy of the company, as well as the financial operations of the company. Employees with higher and higher education are more likely to believe that job information is timely and that meetings are well organized. As a result, employees with higher and higher education estimate that communication contributes to feeling like a significant part of the company, as well as that the exchange of information is good.

In only two items (Q1. Employee reward information is public and Q5. Written instructions and reports are clear and concise), mean values are higher for high school employees. However, these differences are very small and can be ignored.

## **CONCLUSION**

Internal communication items have relatively high (favorable) values in the observed company. The highest average scores have items related to the accuracy and clarity of job descriptions and communication in case of emergencies. This is certainly very desirable for companies in the construction industry. In general, it can be concluded that the internal communication in the company

"KRAFT PORT" DOO for construction, trade and services in Novi Sad, is very favorable and at a high level. The research confirmed the basic and two special hypotheses, which were set in the paper.

Older employees, as well as employees with higher and higher education, more favorably assess the overall importance of communication in the company and the quality of information exchange in the company and are better informed than younger employees and employees with high school. In addition, older employees, as well as employees with higher and higher education, find that meetings are well organized and efficient, that job information is timely, and that job instructions are useful and timely.

Regardless of the fact that the internal communication in the observed company is at a high level, there is still some room for improvement. This mainly refers to a greater degree of information of employees about the remuneration and business of the company. This is especially true in the case of younger employees and employees with high school, according to whom it would be useful to strengthen vertical communication. The top management of the company should consider these suggestions for improvement, and implement them to the extent that it deems it justified and useful.

## REFERENCES

- [1] Andersen, T.J. (2001). Information technology, strategic decision making approaches and organizational performance in different industrial settings. *The Journal of Strategic Information Systems*, 10(2), 101-119.
- [2] Andersen, T.J., Segars, A.H. (2001). The impact of IT on decision structure and firm performance: evidence from the textile and apparel industry. *Information & Management*, 39(2), 85-100.
- [3] Burke, R.J., Wilcox, D.S. (1969). Effects of different patterns and degrees of openness in superior-subordinate communication on subordinate job satisfaction. *Academy of Management Journal*, 12(3), 319-326.
- [4] Downs, C.W., Hazen, M.D. (1977). A factor analytic study of communication satisfaction. *The Journal of Business Communication*, 14(3), 63-73.
- [5] Đorđević, D., Bešić, C. (2005). Odnosi s javnošću. Zrenjanin: Tehnički fakultet "Mihajlo Pupin".
- [6] Ehling, W. P., White, J., Grunig, J.E. (1992). Public relations and marketing practices. In J.E. Grunig (Ed.), *Excellence in public relations and communication management* (pp. 357-394), Hillsdale, NJ: Lawrence Erlbaum Associates.
- [7] García-Morales, V.J., Matías-Reche, F., Verdú-Jover, A.J. (2011). Influence of Internal Communication on Technological Proactivity, Organizational Learning, and Organizational Innovation in the Pharmaceutical Sector. *Journal of Communication*, 61, 150-177.
- [8] Ivancevich, J.M., Matteson, M.T. (2002). *Organizational Behavior and Management*, 6th Edition, New York: McGraw-Hill.
- [9] Nelson, T., Coxhead, H. (1997). Increasing the Probability of Re-Engineering / Culture Change Success Through Effective Internal Communication. *Strategic Change*, 6(1), 29-48.
- [10] Nikolić, M. (2012). Odnosi s javnošću. Zrenjanin: Tehnički fakultet "Mihajlo Pupin".
- [11] Nikolić, M., Terek, E., Vukonjanski, J., Ivin, D. (2012). The impact internal communication on strategic and economic effects in Serbian companies, *Public Relations Review*, 38(2), 288-293.
- [12] Petković, M., Jovanović, M. (2002). *Organizaciono ponašanje - novi koncept vođenja preduzeća*. Beograd: Megatrend univerzitet primenjenih nauka.
- [13] Pincus, J.D., Knipp, J.E., Rayfield, R.E. (1990). Internal communication and job satisfaction revisited: The impact of organizational trust and influence on commercial bank supervisors. *Public Relations Research Annual (PRRA)*, 2, 173-192.
- [14] Robbins, S.P., Judge, T.A. (2009). *Organizaciono ponašanje*, 12th Edition, Zagreb: Mate d.o.o.
- [15] Sprague, R.W., Del Brocco, S.F. (2002). Calculating the ROI on internal communications. *Employment Relations Today*, 29(1), 33-44.
- [16] Yates, K. (2006). Internal communication effectiveness enhances bottom-line results. *Journal of Organizational Excellence*, 25(3), 71-79.

## THE SOCIO-ECONOMIC ASPECTS OF THE CIRCULAR ECONOMY MODEL

Dejan Đorđević<sup>1</sup>, Dragan Čočkalović<sup>1</sup>, Mihalj Bakator<sup>1</sup>, Ljiljana Đorđević<sup>2</sup>, Srđan Bogetić<sup>3</sup>

<sup>1</sup> University of Novi Sad, Technical Faculty "Mihajlo Pupin", Zrenjanin, Serbia

<sup>2</sup> Ministry of Environmental Protection, Environmental Protection Agency

<sup>3</sup> Belgrade Business and Arts Academy of Applied Studies, Belgrade, Republic of Serbia  
e-mail: [mihalj.bakator@uns.ac.rs](mailto:mihalj.bakator@uns.ac.rs)

**Abstract:** The CE model is based on the reuse and recycling of waste with the goal to reduce the overexploitation of natural resources. The current linear model, which is widely used across industries, refers to the use of products and resources and after their exploitation period, they are stored in landfills with no further purpose. In this paper, the CE model is analysed and reviewed in the context of its impact on socio-economic dimensions. The goal is to discuss and propose actions, strategies, guidelines and possible solutions for improving national competitiveness, economic prosperity, standard of living etc. through the CE model. The paper aims to provide a starting point for future research in the domain of CE in the context of socio-economic dimensions.

### INTRODUCTION

According to some understandings [1], circular economy implies the circulation of material and its reuse, which simultaneously uses drastically less energy and water, in some cases over 90%. European Commission [2, p. 1], defines a circular economy as an economy in which "the value of products, materials and resources is retained in the economy as long as possible, and waste is generated to a minimum". Because of these activities, the European Union can establish a sustainable and competitive economy with low carbon dioxide emissions and resource efficiency. Some authors [3, p. 1], view the circular economy as a new paradigm of sustainability. The orientation of the national economy towards the circular economy model enables, on the one hand, to keep the value of products, materials and resources in the economy as long as possible, while on the other hand, waste generation is kept at a minimum. As a result, the development of a sustainable and competitive economy is enabled, in which all resources are used efficiently. Since 2015, the European Union (EU) has adopted a strategic document in the field of sustainable development "Circular Economy Action Plan" and thus began to more actively promote this business model. As a result of the Circular Economy Action Plan, legislative documents have been created that define this area, including the European Stakeholder Platform for the Circular Economy and the Urban Agenda for the EU Partnership on the Circular Economy. In order to adapt to the new business model as efficiently as possible, the European Commission is rapidly working on creating an action plan for the circular economy, which will be a program in which key actors are: businesses, consumers, citizens and NGO representatives, which aims to create a clean and competitive EU economy. The importance of circular economy from socio-economic aspect includes increased standard of living, new opportunities for entrepreneurs, positively affects economic growth and reduces unsustainable resource consumption [4]. Therefore, the CE model can be viewed as important part of sustainable development and as a driver of economic growth on a national level. In addition, the CE model has the potential to increase the number of jobs in the green-tech sector.

In this current paper, the socio-economic aspects of the CE model is analysed. The paper includes an overview on the CE model and its impact on economic and social aspects. Further, suggestions and guidelines for improving socio-economic indicators through the CE model and CE-focused local and national strategies are discussed. The paper includes two main sections (excluding the Introduction and Conclusion sections). The first main section describes and addresses the CE model and its impact and role in the economy. The second main section includes suggestions and guidelines regarding the CE model and improving national competitiveness and socio-economic indicators.

## CIRCULAR ECONOMY AND SOCIO-ECONOMIC DIMENSIONS

Mining has fuelled prosperous growth since the Industrial Revolution. In fact, over the last five decades, global ore use has more than tripled - increasing by a factor of 3.5, from 26.7 billion tons in 1970 to 92.0 billion tons in 2017. The International Resource Panel (IRP) predicts that by 2050, the use of materials will amount to between 170 and 184 billion tons. Part of these billions of tons of extracted ingredients are inherently uncirculated and non-regenerative materials - petroleum products such as gasoline, which are burned in internal combustion engines [5, p. 13]. These and the previously noted issues of the linear consumption model put a tremendous toll on the natural environment as pollution increases along with the number of landfills. Therefore, the CE model is an important step forward when it comes to sustainable development on a national and international level.

According to the Ellen MacArthur Foundation, the principles of circular economy are [6, p. 19]: designing waste management and pollution, keeping products and materials in use, and regenerating natural systems. The transition to a circular economy requires a radical change in the way resources are exploited. Consumers should use and dispose of products efficiently in such a way that they can be reused or, if it is technically or economically unfeasible, recycle them into secondary materials that can enter a new cycle of production and consumption [7, p. 4]. Products should be designed to be reusable, disassembled and recycled. In addition, in the production process, it is necessary to use as much energy from renewable sources as possible. The advantages of the circular economy concepts are significant as it includes the protection of natural resources and the environment, energy saving, increasing employment, as well as improving innovation and competitiveness of the economy. According to some understandings [8], the strategy of waste treatment is marked as "Program 3R": Waste reduction - minimization, reuse of potential waste - Reuse and Recycling - processing of raw materials from waste. The 3R program assumes legal, organizational and educational frameworks, as well as specific mechanisms and instruments for waste management. The application of various waste material recycling procedures reduces the consumption of natural resources by restoring useful substances and achieves energy savings. Recycling has a double effect on society:

- effectively solves part of the environmental problems, caused by environmental pollution with waste materials and
- conditions are created for the realization of production at lower costs, while reducing the volume of use of primary raw materials.

In order to achieve the maximum effects of the recycling process in relation to the mentioned aspects (environmental and economic), it is necessary to be institutionally defined, which implies a precise program orientation and legal regulations, as well as a modern approach to waste management.

Furthermore, an initial group of countries engaged in a circular program, starting from individual nation-states in Europe, to the giant Chinese economy. However, in recent years, a steady stream of new players adopting circular economy policies and roadmaps is witnessed. For example, in 2019, Colombia launched its National Circular Economy Strategy, the first of its kind in Latin America [5, p. 6-10].

When it comes to the domestic economy, the long-term application of the linear concept has brought environmental issues as there is a large number of illegal landfills, and the recycling rate is not adequate. According to the data of the Republic Bureau of Statistics [9], in 2017, 107,949 thousand tons of resources were extracted. The largest amount of extracted resources was fossil fuels - 40,730 thousand tons, followed by biomass - 29,245 thousand tons. Total costs for environmental protection in 2017 amounted to 34,400 million dinars, which is 2.7% less than in 2016 [10]. The share of investments in the structure of environmental protection costs was 19.2%, while current expenditures amounted to 80.8% of the amount spent. The largest share in the structure of investments for environmental protection in 2017 referred to the waste management sector and amounted to 37.5% of the total amount of investments. The largest share in the structure of current expenditures for the environment was related to waste management and amounted to 63.9%.

The CE model addresses the noted issues as it integrates economic aspects, techno-economic aspects, and social aspects of sustainable development [11]. In the same research it was noted that economic

dimensions and technological advancement has a direct impact on social dimensions including the standard of living, salaries, and employment rates.

Furthermore, the CE model promotes and requires new business models and strategies with alternative flow models for supply chains and value chains [12]. The CE model is not only a sustainability model, but rather it integrates a wide array of dimensions from which the socio-economic ones the most dominant, and it promotes solutions for energy-related issues, issues of overexploitation, nature protection and preservation, and improving not only the natural environment, but also rural and urban areas where people live and prosper [12].

It was noted that higher goals and focus on sustainability that is present within the CE model is associated with new job creations, higher technological advancement, higher productivity, and higher rates of creating value on a national level [11]. From a clear social aspect, the CE model can positively affect the four main social areas [12]:

1. Labour practices and decent jobs (employment; quality of life; well-being; fair distribution of income)
2. Human rights (non-discrimination; forced, compulsory, and child labour; security practices; mechanisms that enforce human rights)
3. Society (social networks and cohesion; compliance to public policies; cultural traditions; tourism and recreation; local communities and the sense of belonging)
4. Product responsibility (customer health and safety; private and sensitive data security; customer relationship management)

Overall, it is evident that the CE model affects not only the sustainability from the aspect of product use, reuse and recycling, but it has a broader and large impact on society and economy. In a CE jobs are created, redefined, or substituted. Green jobs rise, while polluting industries can take a hit from the aspect of higher number of job closures. This is why the CE model should be addressed systematically and strategically. Organic, sustainable improvements in all areas that the CE model affects is important.

## **SUGGESTIONS AND GUIDELINES**

In the conditions of intensive application of technologies in modern business, enterprises must harmonize their application, which are increasingly integrated into the modern life of citizens. End users and society must be protected from the negative impact of new technologies.

Governments are now actively working with stakeholders across the entire agricultural supply chain to promote and invest in innovations related to inland agriculture, precision agriculture, food safety and conservation, waste reduction and alternative proteins. Consumer associations have a great influence on the improvement of the supply chain by informing enterprises about their habits and thus contribute to the creation of innovations in the supply chain. As a result of these activities, we have a healthier community and planet. One of the consequences of the COVID 19 pandemic is that it has shown an inadequate attitude of the enterprise towards nature, which has resulted in the fragility of the existing approach to the health care system. People today have turned to nature and a healthy lifestyle for the purpose of their health and mental protection. Also, enterprises and people need to increasingly understand and respect nature and its benefits.

There are also standards covering the field of circular economy and sustainable development such as: the British Standard for Circular Economy (BS8001) and the European Ecodesign Directive, which establish design and communication standards for energy-related products and thus allow energy efficiency. This standard (BS8001) aims to assist organizations and individuals in the process of applying circular and sustainable practices in their business, by improving work processes, providing more circular products and services, or redesigning the entire business model and value proposition. The BS8001 standard is divided into two areas: 1) What is the circular economy and why move to a more circular and sustainable way of working? How to apply the principles of circular economy in an organizational context? [13, p. 1]

Shot and Kanger believe that the CE model can be used as a transformation process to move away from the status quo, in order to create a socio-economic system that is sustainable. Bag et al [14, p. 14-15] believe that innovative solutions can help in the sustainability of CE. According to Khab et al. CE

is a great strategy for achieving corporate sustainability. The analysis of the attitudes of top managers of corporations [15] operating in the global market, among other things, indicates the need for the following guidelines:

1. understand how we work and what we value,
2. understanding of technology,
3. creating a local sustainability system,
4. improving our relationship with nature,
5. shortening the innovation cycle,
6. fight against misinformation,
7. business leaders should be more interested in science,
8. better support for innovation and creativity.

Business practice has shown that in this time characterized by the expansion of information, it is quite easy to spread misinformation that can negatively affect the motivation of employees and end users.

Enterprises are increasingly applying new technologies in their business, and are moving towards the process of digitalization [16]. However, the precondition for the application of new technologies and digitalization is that the enterprise, as well as the national economies themselves, are oriented towards the development of innovation and creativity. As a result of these activities, we have the stimulation of innovators, entrepreneurs and start-ups that bring diversity and creativity to technological innovation.

In the time ahead, national economies should be focused on economic growth along with sustainable social development, taking into account the protection and improvement of the environment and the needs of individuals [17, p. 123]. The noted activities have the potential to increase overall business performance and that is crucial due to the challenges of globalized markets and the new business paradigm [18].

## **CONCLUSION**

The recycling sector is precisely the one that is of key importance for the application of the concept of circular economy. For the development of recycling as an important waste management strategy that determines the circular economy, it is necessary to act in the areas of: education, communication, institutional action, cooperation with partners from abroad, infrastructure construction and more efficient application of knowledge. From the socio-economic standpoint, the CE model includes a large number of indicators and dimensions, as the mechanisms of CE integrates and requires an efficient network between industries. The social impact of CE is inevitable, and the impact is more likely to be positive if organic sustainable development is the goal. In this paper some of the core concepts of the CE model and its influence of socio-economic dimensions were addressed.

The main limitation of the paper is the lack of empirical research. However, taken into consideration that the goal was to review and discuss the CE model in a socio-economic context, this limitation is not severe. In the contrary, this current paper provides a solid starting point for future research. It is recommended to obtain empirical data through survey or other research method, and to expand the impact of the CE model across industries in more detail.

## **REFERENCES**

- [1] OEBS, Cirkularna ekonomija kao šansa za razvoj Srbije, OEBS Misija u Srbiji, Beograd, 2021.
- [2] Euvropska komisija (EK), Komunikacija komisije europskom parlamentu, vijeću, europskom gospodarskom i socijalnom odboru i odboru regija: Zatvaranje kruga — akcijski plan EU-a za kružno gospodarstvo, Europska komisija (EK), COM (2015), p. 614, Bruxelles, 2015.
- [3] Maldonado-Guzmán, G., Garza-Reyes, J.A., Pinzón-Castro, Y., Eco-innovation and the circular economy in the automotive industry, Benchmarking: An International Journal, Vol. ahead-of-print No. ahead-of-print, 2020.
- [4] Laurenti, R., Singh, J., Frostell, B., Sinha, R., Binder, C. R., The Socio-Economic Embeddedness of the Circular Economy: An Integrative Framework, Sustainability, Vol. 10, No. 7, p. 2129, 2018.

- [5] The circularity Gap report, The Platform for Accelerating the Circular Economy (PACE), Amsterdam, 2020.
- [6] Ellen Macarthur foundation, Completing the picture: how the circular economy tackles climate change, 2018. Available at: [www.ellenmacarthurfoundation.org/publications](http://www.ellenmacarthurfoundation.org/publications)
- [7] European Commission Directorate-General for Research and Innovation, Accelerating the transition to the circular economy – Improving access to finance for circular economy projects, Luxembourg: Publications Office of the European Union, 2019.
- [8] Đorđević, Lj., Bijelović, S., Unapređenje procesa reciklaže u domaćoj privredi, Međunarodna konferencija o upravljanju zaštitom životne sredine u elektroprivredi "ELECTRA V", EPS, EPCG i EPRS i Forum za kvalitet Beograd, Divčibare, 2008.
- [9] Indeksi materijalnih tokova u 2017., Beograd, 2018.
- [10] RSZ, Troškovi za zaštitu životne sredine u 2017, RZS, Beograd.
- [11] Tomić, T., Schneider, D. R., Circular economy in waste management – Socio-economic effect of changes in waste management system structure, Journal of Environmental Management, Vol. 267, p. 110564, 2020.
- [12] Padilla-Rivera, A., Russo-Garrido, S., Merveille, N., Addressing the Social Aspects of a Circular Economy: A Systematic Literature Review, Sustainability, Vol. 12, No. 19, p. 7912, 2020.
- [13] BS 8001:2017 - Framework for implementing the principles of the circular economy in organizations – Guide, BSI Standards Institution, 2017.
- [14] Bag, S., Pretorius, J.H.C., "Relationships between industry 4.0, sustainable manufacturing and circular economy: proposal of a research framework", International Journal of Organizational Analysis, Vol. ahead-of-print No. ahead-of-print, 2021.
- [15] Parker, C., 20 views on how to rebuild better after the pandemic, World Economic Forum, 2020. Available at: <https://www.weforum.org/agenda/2020/11/whats-the-biggest-opportunity-for-change-after-the-pandemic/>
- [16] Bakator, M., Đorđević, Lj., Đorđević, D., Circular economy and the domestic economy – challenges and limitations, IX International conference Industrial engineering and environmental protection 2019 (IZZS 2019), Zrenjanin, Serbia, TF Mihajlo Pupin Zrenjanin, pp. 527-532, 2019.
- [17] Bakator, M., Đorđević, D., Čočkalo, D., Developing a model for improving business and competitiveness of domestic enterprises, Journal of Engineering Management and Competitiveness (JEMC), Vol. 9, No. 2, pp. 87-96, 2019.



## IMPROVING COMPETITIVENESS THROUGH TECHNOLOGICAL AND INDUSTRIAL INNOVATION

**Dragan Čočkalović<sup>1</sup>, Mihalj Bakator<sup>1</sup>, Dejan Đorđević<sup>1</sup>, Sanja Stanisavljević<sup>1</sup>,  
Miloš Vorkapić<sup>2</sup>**

<sup>1</sup>University of Novi Sad, Technical Faculty “Mihajlo Pupin”, Zrenjanin, Serbia

<sup>2</sup>University of Belgrade, Institute of Chemistry, Technology and Metallurgy (ICTM) - Center  
of Microelectronic Technologies (CMT), Belgrade, Serbia

e-mail: [mihalj.bakator@uns.ac.rs](mailto:mihalj.bakator@uns.ac.rs)

**Abstract:** The globalization of markets affects how enterprises conduct business. In addition to the challenges of the globalized market, enterprises have to adapt to changes that the coronavirus pandemic has brought to the global business environment. In order for domestic enterprises to achieve competitiveness in such market conditions, technological and industrial innovations are an imperative. In this paper the application of Industry 4.0 technologies is discussed and the potential of such technologies for improving competitiveness of domestic enterprises is addressed. The paper provides a solid basis for future research in this domain.

**Key words:** competitiveness, technology, innovation, enterprises

### INTRODUCTION

The rapid development of information-communication technologies (ICT) has intensified the globalization of markets. Hence, the modern market is characterized by constant and simultaneous fragmentation and segmentation as well by the intensification of competitive relations [1]. In such conditions, markets are “levelled”, meaning that small and medium-sized enterprises (SMEs) are competitors to global corporations, and vice-versa. As noted earlier, this indicates intensified competitive relations, which further indicates that achieving and maintaining a competitive position on the market is a challenge for the vast majority of enterprises. Further, if a transitional business and economic environment is added to the “equation”, the challenges and barriers are even more pronounced. Domestic enterprises in the Republic of Serbia, besides the continuous pressure from globalized markets, also face other issues, which hinder their competitive ability on the international market [2]. Some of these main issues which negatively affect competitive ability include low productivity, low product and service quality, old and obsolete manufacturing equipment, low levels of innovation, and lack of application of modern management tools and techniques [3]. In addition to the challenges, domestic enterprises, but also enterprises overall have to adapt and evolve into the modern business environment which is not only affected by globalization, but by the fourth industrial revolution - Industry 4.0, as well. Namely, in order to effectively conduct business within the frameworks of Industry 4.0, enterprise have to implement some form of modern ICTs. Now, the modern ICTs, which characterize Industry 4.0, include big data analytics, wireless sensors, cloud-based technologies and solutions, advanced cybersecurity, RFID (Radio Frequency Identification etc.) [4]. These technologies have the potential to improve business processes and activities including quality, productivity, innovation capacity and overall business performance. This further indicates that such technologies have the potential to improve competitive ability of domestic enterprise on the international market. However, it is important to note that implementing any of these modern ICTs doesn't necessarily guarantee improved business performance and competitiveness. Due to the complex and dynamic changes on the market and depending on the size and industry of the enterprise, the positive effects of modern ICT application vary.

In this paper the competitiveness of domestic enterprises and the national competitiveness of the Republic of Serbia is addressed along with the potential of Industry 4.0 technologies for improving competitiveness as well as business performance of domestic enterprises. The analysis of the noted potential is viewed through the potential improvement in innovation, quality, productivity and overall business performance and competitive ability of the enterprise. The paper includes four main sections (excluding the Introduction and Conclusion sections). The first section analyzes the competitiveness of domestic enterprises in more detail. Additionally, national competitiveness is addressed. In the second

section the framework of Industry 4.0 is discussed. Afterwards, the application and potential of Industry 4.0 technologies for improving innovation and overall competitiveness is investigated. Finally, based on the findings of the conceptual study, suggestions and guidelines for improving business performance and competitiveness of domestic enterprises are proposed.

Overall, the paper aims at simultaneously providing a concise and thorough overview on the potential of advanced ICTs in transitional economies. The paper contributes to existing body of literature in this domain, as there is lack of studies, which address the noted constructs in developing countries.

## COMPETITIVENESS OF DOMESTIC ENTERPRISES AND NATIONAL COMPETITIVENESS

As noted in the Introduction section the competitiveness of domestic enterprises is inadequate, which further results in insufficient national competitiveness compared to EU countries. Now, the lack of high quality products and services which satisfy customers; the lack of productivity which further increases operational costs and annuls the possibility for a competitive pricing strategy on the international market; the lack of modern manufacturing tools and equipment which reduces productivity and quality; and inadequate application of management tools and techniques which negatively affect employee satisfaction, productivity and overall organizational performance; are the main pillars of low competitive ability of domestic enterprises and the competitiveness of the whole domestic economy [3]. Additionally, in the Republic of Serbia investments into research and development was 0.78% of total GDP in 2014 (latest data), while the EU average was 2.1% [5]. If the amount of GDP is also taken into consideration, then these percentages are even more inadequate when it comes to investments into R&D in Serbia. A section of the Strategy and Policy for the Development of Industry of the Republic of Serbia for the period 2011-2020, estimated that 25% of GDP will be invested in changes in export technological structure of the domestic manufacturing industry. However, the average investments for the period was 18.8%, and this is lower from neighboring countries such as Albania (27.9%), Croatia (25.5%), Bosnia and Herzegovina (22.7%), Hungary (23.6%), while the global average was 23.6%. In addition to these grim results of the domestic economy, when it comes to investments, the inflow of foreign direct investments are 4.9% of GDP, an average well below from the projected percentages [6]. Further, in order to concisely present the position of Serbia regarding national competitiveness, competitiveness ranks from the Competitiveness Report (by the World Economic Forum) [7], are given in Table 1.

**Table 1.** Competitiveness ranks of countries

Country	Competitiveness rank (out of 141 countries)
Serbia	72
Croatia	63
Slovenia	35
North Macedonia	82
Bosnia and Hercegovina	92
Montenegro	73
Romania	51
Hungary	47
Austria	21
Albania	81
Germany	7

According to the data presented in Table 1, it is evident that Serbia lags behind its neighboring countries as well as countries - member states of the EU, when it comes to overall competitiveness ranks. The main issues which affect competitive ability of the domestic economy include customer sophistication; professional management reliability; naval docking service efficiency; tax distortion effects on competitors; overall attitudes towards entrepreneurship; employee and employer

cooperation; levels of private property security, effectiveness of law regulation; cluster development levels; and employee training intensity [7]. Additionally, it was noted that sustainable economic growth, industrial export growth, and innovative entrepreneurship growth are crucial development factors for improving the competitiveness of the Serbian economy [8].

Based on the mentioned issues of domestic enterprises and the domestic economy overall, it can be argued that there is a need for systematic, structured and dynamic changes when it comes to quality, productivity, manufacturing technology, innovation and management concepts. Now, besides the globalization of markets, another major factor affects the process of conducting business not only for domestic enterprises, but enterprises overall. This factor is Industry 4.0. Brought upon the modern business environment by the rapid development of ICTs, Industry 4.0 creates new types of barriers when it comes to achieving and maintaining a competitive position on the international market. Namely, enterprises have to innovate from the aspect of implementing and applying modern ICTs, more precisely technologies which outline the framework of Industry 4.0.

## **THE FRAMEWORK OF INDUSTRY 4.0 AND MODERN ICTS**

Industry 4.0, in a simple manner, can be viewed as the digitalization of manufacturing. The main framework of Industry 4.0 includes the involvement, redesign and redefining of core functions on which smart processes are based, and which result in smart products and services. The core functions are product development, marketing, manufacturing, logistics, distribution, sales and post-purchase services [9]. In the same study it was noted that the main framework of Industry 4.0 includes supporting technologies such as RFID (Radio Frequency Identification), sensors and wireless sensors, actuators, virtualization technologies (cloud-based solutions), and mobile technologies. Further, according to another study, Industry 4.0 technologies, which are the pillars of the framework, can be categorized into two main groups. The first group includes front-end technologies such as smart supply chains, smart working, smart manufacturing, and smart products. The second group are base technologies including Internet of Things - IoT, Cloud computing, Big Data and Analytics [10].

It is also important to note that implementing and applying some of the noted technologies, and to conduct business within the framework of Industry 4.0, enterprises have to restructure their business models as Industry 4.0 based business models are heavily linked to open innovation, mass customization, crowdsourcing, product service systems and Internet of Things [11]. These technologies and concepts are described as fundamental technical enablers. The necessity for such technologies and concepts comes from the intensification of global competition [11]. Therefore, it can be argued that domestic enterprises have to evaluate their business models and business processes in order to effectively implement and apply one or more modern ICTs. These modern ICTs, as the pillars of Industry 4.0 can pose a challenge for enterprises as they often require financial and human resources.

Additionally, the application of a Digital twin technology concept may be proven to be effective as it integrates a physical system and a digital version of the system which can act as a controlling element of the physical system [12]. Overall, conducting business within the framework of Industry 4.0 and applying modern ICTs involves autonomous production lines, business process integration through the Internet, horizontal integration for increased and more effective collaboration among enterprises,, vertical integration of various subsystems with the goal to improve flexibility of production lines, and end-to-end integration which involves supporting product and service customization as any point in the supply chain [13].

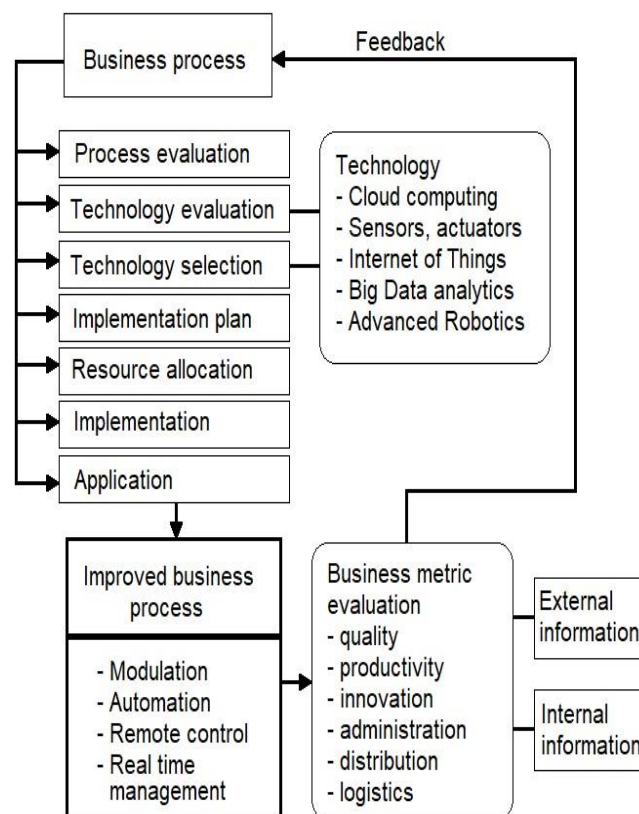
Now, can enterprises, more precisely, domestic enterprises apply some or all of the previously noted modern ICTs? Short answer: Yes. However, the process of digitalization and improving overall business performance and competitiveness is not simple, and certainly, there are financial barriers, as well as necessity for skilled employees who can manage a new ICT solution in the enterprise. Even though there are risks when it comes to restructuring business models in accordance with modern ICTs, enterprises have to be aware that the competition on the international market is fierce, thus modern ICT implementation and application is practically not an option, but rather an imperative (if the goal is to improve competitive ability). This doesn't indicate that enterprises should implement any ICT solution into their business processes, but to effectively and thoroughly evaluate their business

model and to adapt to the changes and requirements of the modern globalized market, through the implementation of technologies which characterize the fourth industrial revolution.

Further, in the next section the application of modern ICTs in domestic enterprises is addressed. Here, a theoretical model is presented with the goal to concisely present the process of implementing an ICT solution into an existing enterprise. In addition, the potential of ICT application on innovation development is analyzed, as well as the overall influence of Industry 4.0 technology application on business performance and competitiveness of domestic enterprises is discussed. From here, suggestions for improving competitiveness are discussed.

### APPLICATION, INNOVATION, AND IMPROVING COMPETITIVENESS

The effectiveness of implementing and applying an Industry 4.0 technology depends on the organizational structure, the effectiveness of the technology itself, and the enterprise's readiness for change, which the technology brings [14]. Further, Industry 4.0 technologies can be implemented and applied in various business processes including supply chain innovation [15], automation and modular manufacturing solutions [16], cyber-physical system synergy with value stream mapping [17], innovative solutions in logistics [18], lean manufacturing [19], and overall sustainability of business performance [20]. The wide application of Industry 4.0 technologies is evident. An important factor of improvement with these technologies is innovation and its effect on competitiveness. It can be safely argued that improved innovative capability can lead to products and services, which can increase customer satisfaction by fulfilling customers' needs and wishes, which further positively mirrors on the enterprise's competitive ability. On Figure 1, a concise theoretical model for implementing and applying modern ICTs is presented.



**Fig. 1.** Model for Industry 4.0 technology implementation and application

The theoretical model presented on Figure 1, includes several main elements. The implementation and application process starts with the business process. The noted process is evaluated as in drawbacks, bottlenecks, quality and productivity issues, as well as market performance issues are identified and clearly defined. Based on the output (report) of the process evaluation, technology evaluation is

conducted. This includes the identification of the most appropriate technological solution or solutions for specific business activities. In addition, cost-to-benefit ratios have to be calculated as well adequate risk management has to be put in place.

After technology evaluation, technology selection takes place. Here, providers are contacted and the adequate type of a specific technological solution is selected. Based on the selected technology an implementation plan is created. Afterwards, resource allocation (financial and human) is necessary, in order to effectively implement the technology or technologies. From here, the selected technology is implemented in accordance with the created implementation plan.

Next, the implemented technological solution is applied. This further results in an improved business process. The improvement may be in the form of automation, modulation, remote control and real-time management. Based on the conducted improvements, business performance metrics are evaluated along with other external and internal metrics. This feedback information is sent to the beginning of the process where another cycle is initiated where evaluation, optimization, modification or even another technology implementation may occur.

Now, the model presented on Figure 1. is generic in approach. This way a more concise overview of the potential process of Industry 4.0 implementation and application can be obtained. The main areas on which domestic enterprises should focus are quality, productivity and innovation. Improving these crucial business metrics can dramatically improve the competitive ability of the enterprise. Certainly, innovation is a key element which brought by implementing a modern ICT which characterize the fourth industrial revolution. In the next section, suggestions and guidelines for improving the competitiveness of domestic enterprises are discussed.

## **SUGGESTIONS FOR IMPROVING COMPETITIVENESS**

Europe In accordance with the analyzed literature in the domain of Industry 4.0 technologies and based on the presented theoretical model, the following suggestions and guidelines for improving competitiveness of domestic enterprises are proposed:

- The possibilities of Industry 4.0 technologies should be introduced systematically on all levels of conducting business. Including micro, small, medium-sized and big enterprises.
- Enterprises should consider implementing a modern ICT with the goal to improve certain if not all areas of conducting business.
- Quality, productivity and innovation should be the three main focus points when considering new ICT implementation. Innovation should be the core through, which the other two metrics would be improved.
- Innovation should be evaluated pre and post implementation of a new technology. This way additional optimizations and corrections can be introduced in order to increase innovation capacities.
- Innovation should not be focused only on products and services, but also on business processes and overall on the business model. Innovation should be looked for in the external and internal business environment as well. Employees should be encouraged to share their ideas and propose suggestions when it comes to improving, innovating or optimizing a specific business process.
- When considering the implementation of an Industry 4.0 technology, enterprises have to clearly define their operational goals as well as their long-term strategic goals. Projecting and predicting future trends and needs of the enterprise can save resources later on, as upgrades would be rather a minor change rather than an expensive overhaul of a previously implemented ICT.
- Employee skill and knowledge development is an imperative for implementing and applying a modern ICT solution. Employees should be involved in the implementation process as this would reduce resistance to the new technology.
- Along with a modern ICT implementation and application, managers have to practice modern management tools and techniques as well. Without an adequate management approach changes occurring within the enterprise (new ICT implementation, application etc.) can bring more risk to table, potentially increasing costs, reducing the positive effects,

and even complete failure of functional implementation and application of the new ICT solution.

Overall, domestic enterprises can benefit from implementing and applying a modern ICT, which is in accordance with the Industry 4.0 framework. Now, the type of technological solution depends on the size, industry, needs and available resources of the enterprise. Fortunately, there are many various modern ICT solutions, which can improve a certain business process in one way or another. For example, simple cloud-based solutions are far less expensive compared to automation and robotics in manufacturing. This is important, especially for micro, small and even some medium-sized enterprises, as these organizations often can't invest into complex and expensive infrastructures and technological solutions. Modern ICTs can certainly be expensive, however there are relatively affordable solutions, too.

Furthermore, it is not enough to implement a new technology. Domestic enterprises, and enterprises overall have to aim and focus on specific goals and targets of improvement, which may include innovation intensity, product and service quality, or productivity. Without a defined goal, the post-implementation phase can "fall flat", leading to inadequate application of the newly introduced ICT. In addition, the concept of sustainability is crucial, as any implemented and applied solution has to be sustainable in the long-term, and its potential negative effects on the environment should be minimal or non-existent if possible.

## **CONCLUSION**

Achieving competitiveness on the international market presents a challenge for the majority of enterprises. When it comes to domestic enterprises, the barriers and challenges for achieving and maintaining a competitive position on the international market are even more pronounced. As noted earlier in the paper, the main reason behind such inadequate competitive ability are the lack quality, productivity, innovation, modern manufacturing equipment and the lack of modern management concept practices.

Based on the analyzed literature it can be concluded that the complexity of the international market can't be "conquered" in a simple manner. Due to technological advances in various industries, the competition is intensified. Modern ICTs, which characterize the fourth industrial revolution, clearly have the potential to improve business performance and competitiveness. In this paper, a theoretical model for implementing and applying modern ICTs with the goal to improve specific business processes is presented. The model is generic in nature, and it aims to provide a basis for future research. ICTs have the ability to adapt to various business models, thus innovation, which derives from such technologies is organic in nature. This further indicates, that mass adoption of ICTs in enterprises won't create saturation from a technological aspect, but it would rather improve specific attributes of various products and services.

Now, the main limitation of this paper is the lack of empirical analysis of data collected from various enterprises. However, the paper contributes to the existing body of literature through a concise, and yet a thorough overview on the dynamics, which are at play when the implementation and application of ICTs in domestic enterprises are analyzed. Overall, the paper provides a solid cornerstone for developing new studies in this domain.

## **ACKNOWLEDGEMENT**

This work is a result of the project financed by the Ministry of Education, Science and Technological Development of the Republic of Serbia, Grant TR 35017.

## **REFERENCES**

- [1] Bakator, M., Đorđević, D., Čočkalović, D., Developing a model for improving business and competitiveness of domestic enterprises, *Journal of Engineering Management and Competitiveness (JEMC)*, Vol. 9, No. 2, pp. 87-96, 2019.

- [2] Bakator, M., Đorđević, D., Čočkalović, D., Modelling the Influence of Product Development on Business Performance and Competitiveness in Manufacturing Enterprises, *Technical Gazette - Tehnički Vjesnik*, Vol. 26, No. 6, pp. 1628-1634, 2019.
- [3] Xu, L. D., Xu, E. L., Li, L., Industry 4.0: state of the art and future trends, *International Journal of Production Research*, Vol. 56, no. 8, pp. 2941-2962, 2018.
- [4] World Bank, Research and development expenditure (% of GDP) - Serbia, 2020. Available at: <https://data.worldbank.org/indicator/GB.XPD.RSDV.GD.ZS?locations=RS-EU>
- [5] Čorović, E., Gligorijević, Ž., Manasijević, A., Revealed comparative advantages and competitiveness of the manufacturing Industry of the Republic of Serbia, *Economic Themes*, Vol. 57, No. 3, pp. 307-327, 2019.
- [6] The Global Competitiveness Report 2019, World Economic Forum, 2019. Available at: [www.weforum.org](http://www.weforum.org)
- [7] Aničić, J., Aničić, D., Kvrđić, G., Sustainable growth and regional competitiveness of Serbian economy, *Ekonomika*, Vol. 65, No. 2, pp. 65-74, 2019.
- [8] Salkin, C., Oner, M., Ustundag, A., Cevikcan, E., A Conceptual Framework for Industry 4.0, *Industry 4.0: Managing The Digital Transformation*, pp. 3–23, 2017.
- [9] Frank, A. G., Dalenogare, L. S., Ayala, N. F., Industry 4.0 technologies: implementation patterns in manufacturing companies, *International Journal of Production Economics*, 2019.
- [10] Weking, J., Stöcker, M., Kowalkiewicz, M., Böhm, M., Krcmar, H., Leveraging industry 4.0 – A business model pattern framework, *International Journal of Production Economics*, p. 107588, 2019.
- [11] Raza, M., Kumar, P. M., Hung, D. V., Davis, W., Nguyen, H., Trestian, R., A Digital Twin Framework for Industry 4.0 Enabling Next-Gen Manufacturing, 2020 9th International Conference on Industrial Technology and Management (ICITM), 2020.
- [12] Dalmarco, G., Ramalho, F. R., Barros, A. C., Soares, A. L., Providing industry 4.0 technologies: The case of a production technology cluster, *The Journal of High Technology Management Research*, p. 100355, 2019.
- [13] Cimini, C., Boffelli, A., Lagorio, A., Kalchschmidt, M., Pinto, R., How do industry 4.0 technologies influence organisational change? An empirical analysis of Italian SMEs, *Journal of Manufacturing Technology Management*, ahead-of-print(ahead-of-print), 2020.
- [14] Hahn, G. J., Industry 4.0: a supply chain innovation perspective, *International Journal of Production Research*, pp. 1–17, 2019.
- [15] Marcon, P., Zezulka, F., Vesely, I., Szabo, Z., Roubal, Z., Sajdl, O., ... Dohnal, P., Communication technology for Industry 4.0. 2017 Progress In Electromagnetics Research Symposium - Spring (PIERS), 2017.
- [16] Pagliosa, M., Tortorella, G., Ferreira, J.C.E., Industry 4.0 and Lean Manufacturing: A systematic literature review and future research directions, *Journal of Manufacturing Technology Management*, Vol. 32 No. 3, pp. 543-569, 2019.
- [17] Witkowski, K., Internet of Things, Big Data, Industry 4.0 – Innovative Solutions in Logistics and Supply Chains Management, *Procedia Engineering*, Vol. 182, pp. 763–769, 2017.
- [18] Wagner, T., Herrmann, C., Thiede, S., Industry 4.0 Impacts on Lean Production Systems, *Procedia CIRP*, Vol. 63, pp. 125–131, 2017.
- [19] Haseeb, M., Hussain, H.I., Ślusarczyk, B., Jermsittiparsert, K., Industry 4.0: A Solution towards Technology Challenges of Sustainable Business Performance, *Social Sciences*, Vol. 8, No. 5, p. 1, 2019.

## ACHIEVING SUSTAINABLE DEVELOPMENT THROUGH THE CONCEPT OF SOCIETY 5.0

Mihalj Bakator<sup>1</sup>, Dejan Đorđević<sup>1</sup>, Dragan Čočkalović<sup>1</sup>, Cariša Bešić<sup>2</sup>,  
Dragana Milosavljević<sup>1</sup>

<sup>1</sup>University of Novi Sad, Technical Faculty "Mihajlo Pupin", Zrenjanin, Serbia

<sup>2</sup>University of Kragujevac, Faculty of technical science in Čačak, Svetog Save 65,  
Čačak 32000, Republic of Serbia

e-mail: [mihalj.bakator@uns.ac.rs](mailto:mihalj.bakator@uns.ac.rs)

**Abstract:** Sustainable development in the context of Sustainable Development Goals (SDGs) includes a wide array of socio-economic and political factors. In this paper, the sustainability of domestic enterprises and the sustainable development of the domestic economy is addressed. More precisely, achieving and intensifying the potential of sustainable development through the concept of Society 5.0 is analyzed and discussed. The main goal of the paper is to review and analyze the concept of Society 5.0 and its narratives in order to propose potential strategies and actions for improving socio-economic sustainability on a national level, and improved sustainability of domestic enterprises and how they conduct business in the modern business environment. The paper provides valuable insight into the dynamics behind the concept of Society 5.0. It certainly can shift business perspectives, which can have a significant impact on sustainable development across multiple SDGs. Additionally, the paper provides a solid basis for future research in the domain of sustainable development and the concept of Society 5.0.

**Key words:** sustainable development, enterprises, Society 5.0, Serbia, competitiveness

### INTRODUCTION

In the coming decades, sustainability will have a main and crucial role in economic development and economic growth. The current, predominant means of production are not sustainable as it involves overexploitation and the depletion of natural resources with an increased and unsustainable rate [1]. The concept of sustainability as an important challenge for enterprises and national economies is presented through the Sustainable Development Goals (SDGs). Enterprises have to integrate the SDGs into their strategy, mission, and vision. This further indicates that the concept of sustainability has to be present within supply chains, value chains, and to be supported by the manager and stakeholders, in order to conduct business in a long-term sustainable way [2]. Sustainable business processes are an imperative when it comes to achieving and maintaining a competitive position on the market. Domestic enterprises face big challenges when it comes to conducting business on the international market that is affected by the globalization of markets, the rapid development of information-communication technologies (ICTs), and the post-pandemic business paradigm [3]. The challenge and the road towards implementing mechanisms that support sustainable business process requires systematic changes of how conducting business is perceived. Further, the vision of the Society 5.0 concept (Japan's nation-wide effort and strategy) includes the focus on social and ecological aspects of conducting business. More precisely, it doesn't abandon the profit motives, but rather, it propagates technological development and innovations to be the cornerstones of societal needs [4]. The aspect of sustainability of Society 5.0 can be noted as more broad and society-focused application of modern ICTs compared to the framework of the fourth industrial revolution - Industry 4.0 [5].

In this paper, the process and possibilities of achieving sustainable development in domestic enterprises through the concept of Society 5.0 is analyzed. The paper includes three main sections (excluding the Introduction and Conclusion sections). After the Introduction, the first section presents the domestic economy, its challenges, weaknesses and future trends. The second section addresses the concept of Society 5.0 and its narratives and potential when it comes to sustainable enterprises and sustainable economy. The third section proposes suggestions and guidelines for achieving sustainable development in the context of domestic enterprises and the domestic economy. The main goal of this paper is to review and discuss the concept of Society 5.0 and its potential in a transitional economy.



## DOMESTIC ECONOMY AND CHALLENGES OF SUSTAINABILITY

Domestic enterprises face big challenges when it comes to achieving and maintaining a competitive position on the international market. This further reflects the domestic economy, which is hit by the global pandemic of coronavirus, and the overall national competitiveness is inadequate compared to developed countries. The main reason behind the lack of competitiveness is low productivity, low quality, inadequate application of modern management methods and techniques, and inadequate application of modern ICTs [6]. Furthermore, when it comes to the domestic economy and sustainable development from the aspect of SDGs [7]:

- Development of society is one of the lowest ranked in Europe;
- GDP per capita is one of the lowest in Europe;
- A big issue are high unemployment rates and high overall unemployment rates;
- In order to increase the decency of employment an increase of new jobs of almost 75% is required;
- Agriculture is based on traditional technologies with lack of smart agriculture concepts;
- Knowledge and technology are not adequately applied across industries;
- Education is adequate and in line with the European Union education system;
- Every fourth person is under the relative poverty line;
- Single mothers, minorities, people with disabilities and other vulnerable groups face higher levels of inequality compared to others;
- There is a trend of population decline, and it is expected to decline by 8% by 2030;
- The agricultural sector is the "bread winner" of GDP;
- Small and medium-sized enterprises are key actors in the export of technologically enhanced goods and technological services.

Additionally, the newest report on sustainable development from the aspects of SDGs in Serbia has noted [8]:

- There is an increase in poverty rates, and the number of people who are malnourished;
- There is a positive index regarding healthcare services;
- There is a trend that not everyone has the same chances and opportunities for quality higher education;
- Gender equality has improved, and overall women have more rights;
- There is a severe lack of adequate water management and exploitation, as the current model is not sustainable and harms the environment;
- There is a an increase of population percentage who have access to electric power;
- Economic growth is small, but not dismissible;
- Strategies to increase the number of decent jobs are implemented;
- There is a decrease of youth unemployment, however, a large number of young people leave the country to work in Western Europe;
- There is still an inadequate percentage of how manufacturing resources are used, but there is a slight improvement when it comes to productive resource use in manufacturing industries;
- There is a small improvement when it comes to sustainable industrialization and the increase of investments in technological research and development;
- Fiscal policies are improved as well as social security and equality among citizens;
- There is a decrease and still inadequate percentage of recycling and reuse of waste in manufacturing and other industries;
- Productiveness of resources is inadequate and trend show a decrease;
- A moderate increase is noted when it comes to securing the preservation of forest, mountains and swamps;
- There is a improvement in the domain of partnerships with other countries when it comes to technological research and innovation development.

It is evident that depending on which aspect of sustainable development is observed the status of the domestic economy and national outlook regarding sustainability is not sufficient in the long-term. This further indicates that in order to increase sustainable development on a national level, systematic changes are an imperative. Society 5.0 as a concept and initiative had the potential to drive sustainable development in the context of SDGs. However, Society 5.0 is not a quick solution for sustainability issues, but rather it presents an initiative that includes advanced ICTs as means of integration of socio-economic factors with the goal to improve the well-being of society without overexploiting the environment. It is centered around societal dimensions, market dynamics and sustainable practices.

### **THE FRAMEWORK OF SOCIETY 5.0**

The concept of Society 5.0 can be viewed as an initiative, which was proposed by the Japanese government in 2016 [9]. The focus of the Society 5.0 initiative is on the wellbeing of people, increased human security, environmental protection and preservation and collaboration between social, economic, and political ecosystems through cyber-physical systems [9].

Before this approach towards building sustainable societies and achieving SDGs, society as whole, was viewed as a group of people that lived harmoniously with its environment and conducted hunting as means of survival (Society 1.0). Next, Society 2.0 was viewed as groups of people who gathered to conduct agricultural cultivation. nation building. Compared to Society 1.0, Society 2.0 had increased levels of organization. Society 3.0 focuses on industrialization and mass production, while Society 4.0, as an information society, aims at adding value through ICTs. More precisely, Society 4.0 adds economic value by connecting intangible assets [10].

As noted earlier, Society 5.0 is based on huge amounts of data that is accumulated through a cyberspace. This data is retrieved, analyzed and stored in various systems [10]. These systems include data centers, cloud computing technologies, service solutions, business application, key value storages regarding social society-focused industries [9]. Society 5.0 aims at increasing the standard of living through financial and technological advancement. It closely takes into consideration SDGs, and even though originates in Japan, it is meant for the general public in other countries, too [10]. The main platforms and concepts that define and provide a framework for Society 5.0 in the context of creating a Super Smart Society are [9]:

- Energy value chains with the goal to reduce waste in energy consumption;
- New manufacturing systems, which are agile and increase productivity;
- Regional inclusive care systems;
- Infrastructure maintenance systems and update platform;
- Resilience of society against natural disasters and harsh living conditions;
- New business models and service models for increased value for consumers;
- Hospitality systems and platforms;
- Global environment information network with management and distribution platforms;
- Integrated material development systems and necessary supporting infrastructures;
- Smart manufacturing systems;
- Smart food-chain systems for reducing waste;
- Intelligent transportation systems with advanced logistics and efficient distribution;
- Advanced social security implementation;
- Utilization of data for human resource development;
- Regulatory reforms on national and international levels for new services;
- Developing information communication platforms;
- Standardization of interfaces and data formats for increased application;

It is evident that the adoption of ICTs in multiple dimensions of society is intensified. The concept of Society 5.0 in the context of sustainable development can be viewed as the relation between societal dimensions with the technology, science, industry, and economy itself with the goal to create sustainable mechanisms of conducting business and market dynamics [10]. This further indicates that Society 5.0 can be demonstrated as a driving force for several SDGs - mainly the socio-economic goals. Additionally, when analyzing the concept of Society 5.0, a positive outlook is observed

regarding the rapid and dynamic advancement of ICTs within Industry 4.0. Namely, Society 5.0 goes beyond the industrial application of advanced ICTs (cloud computing, Big Data Analytics, Internet of Things, cyber-physical systems etc.), and includes the societal aspects as well [12]. Industry 4.0 and Society 5.0 are based on similar technologies, however the core principles are different, as Industry 4.0 itself is not necessarily sustainable, especially when the creation and trade of value is taken into consideration. Society 5.0 includes all the SDGs (some directly, others indirectly) [13, 14]. Society 5.0 for achieving SDGs includes remote sensing and oceanographic data for water management; meteorological and other observation data for resolving climate change issues; smart city development with economic efficiency; development of global innovation ecosystems; building resilient infrastructures; increasing food production with smart agriculture; developing early warning systems for preventing the spread of diseases; developing e-learning systems with advanced ICTs; empowerment of women through various learning platforms; effectively managing electric power through smart grid systems [11]. Overall, it is evident that the Society 5.0 initiative integrates important sustainable development issues and ways to solve them. In the next section, the potential of Society 5.0 in the context of domestic enterprises and the domestic economy is discussed.

## **SUGGESTIONS AND GUIDELINES**

Based on the analyzed literature and reports, domestic enterprises and domestic economy could implement some of the narratives of the Society 5.0 initiative with the goal to improve sustainability in various socio-economic indicators. Taking into consideration how Japan is rolling out strategies and frameworks for the Society 5.0 initiative and the reality of the domestic economy and domestic enterprises, the following suggestions and guidelines for improving sustainable development are noted:

- Enterprises should evaluate their supply chains and consider strategies, which are optimized and sustainable in the long-term;
- Enterprises have to address their impact on the environment and on people's lives;
- The impact of conducting business has to be analyzed and negative effects have to be limited to sustainable levels;
- National strategies have to be considered regarding education and support for individuals and groups who are in disadvantageous position (minorities, people with disabilities, single mothers, etc.);
- Water management with focus on spring water preservation and reducing overexploitation should be prioritized as this is a key indicator of society's wellbeing;
- The healthcare systems have to go through a reform and bring the quality of public healthcare with the care provided in private hospitals;
- Enterprises should focus on effectively using resources;
- Campaigns on sustainability regarding various consumer products should be initiated with the goal to create gap in competitiveness that could drive sustainability across industries;
- SMEs should focus on creating value to the customer and society overall;
- National strategies and campaigns should be conducted in the domain of social security;
- Enterprises should implement advanced ICTs in order to bring their business closer to sustainable levels.

The noted suggestions take into consideration the integral parts that define Society 5.0 and the capabilities of the domestic economy and domestic enterprises. Are these suggestions sufficient? That is to be seen in the forthcoming period. The literature and data suggest that the mechanisms that define Society 5.0 could be implemented in some capacity within developing countries and enterprises from developing countries - in this case Serbia, and Serbian enterprises.

## **CONCLUSION**

In the modern business environment sustainable developing is becoming an imperative as natural resources are overexploited and freshwater sources are contaminated. Conducting business in the context of SDGs requires a wide array of changes on how business is perceived. Domestic enterprises

face serious challenges from globalization to Industry 4.0 technologies that increase the threshold for achieving competitive ability on the international market. Additionally, advanced ICTs that are the cornerstone of Industry 4.0 bring new issues regarding employment and decent job markets. This further shifts the societal dimensions as the number of jobs across declines due to advanced ICTs. Now, the concept of Society 5.0 takes this into consideration and navigates economic development and encourages business strategies to focus on the societal dimensions. More precisely, conducting business should be in-sync with the prosperity of society and should be in accordance with the SDGs. In this paper the situation of the domestic economy and domestic enterprises is discussed within the context of sustainable development. Society 5.0 as an initiative originating from Japan, has been analyzed with the goal to propose potential actions and strategies that could improve sustainable development. The main limitation of paper is the lack of empirical data. However, the paper provides a solid starting point for future research in this domain and highlights the possibilities of the Society 5.0 concept in a transitional environment.

## REFERENCES

- [1] Đorđević, D., Bakator, M., Čočkalović, D., Đorđević, Lj., Bogetić, S., Improving competitiveness through the circular economy model, Proceedings of the XI International Symposium Engineering Management and Competitiveness (EMC 2021), pp. 16-21, Zrenjanin, SRB: Technical faculty "Mihajlo Pupin" in Zrenjanin, 2021.
- [2] Rendtorff, J. D., Sustainable development goals and progressive business models for economic transformation, Local Economy: The Journal of the Local Economy Policy Unit, Vol. 34, No. 6, pp. 510–524, 2019.
- [3] Bakator, M., Đorđević, D., Čočkalović, D., Developing a model for improving business and competitiveness of domestic enterprises, Journal of Engineering Management and Competitiveness (JEMC), Vol. 9, No. 2, pp. 87-96, 2019.
- [4] Holroyd, C., Technological innovation and building a "super smart" society: Japan's vision of society 5.0. Journal of Asian Public Policy, pp. 1–14, 2020.
- [5] Potočan, V., Mulej, M., Nedelko, Z., Society 5.0: balancing of Industry 4.0, economic advancement and social problems, Kybernetes, Vol. 50, No. 3, pp. 794-811, 2021.
- [6] Popović, M., Rajović, B., Impact of the Industry 4.0 on smart city development. Journal of Engineering Management and Competitiveness (JEMC), Vol. 11, No. 1, pp. 64-76, 2021.
- [7] Ceves, Održivi razvoj Srbije, 2018. Available at: [https://ceves.org.rs/wp-content/uploads/2018/08/Bro%C5%A1ura\\_Odr%C5%BEivi-razvoj-Srbije\\_Kako-stojimo.pdf](https://ceves.org.rs/wp-content/uploads/2018/08/Bro%C5%A1ura_Odr%C5%BEivi-razvoj-Srbije_Kako-stojimo.pdf)
- [8] RZS, Izveštaj o napretku u ostvarivanju ciljeva održivog razvoja do 2030. godine u Republici Srbiji. Available at: [https://www.stat.gov.rs/media/5682/izvestaj-o-napretku-u-ostvarivanju-ciljeva-odrzivog-razvoja-do-2030-godine-u-srbiji\\_web.pdf](https://www.stat.gov.rs/media/5682/izvestaj-o-napretku-u-ostvarivanju-ciljeva-odrzivog-razvoja-do-2030-godine-u-srbiji_web.pdf)
- [9] Shiroishi, Y., Uchiyama, K., Suzuki, N., Society 5.0: For Human Security and Well-Being. Computer, Vol. 51, No. 7, pp. 91–95, 2018.
- [10] Onda, O. Japan's society 5.0: Going beyond Industry 4.0, Business and Economics Journal, Vol. 10, No. 2, pp. 1-6, 2019.
- [11] Serpa, S., Ferreira, C. M., Society 5.0 and sustainability digital innovations: A social process, Journal of Organizational Culture, Communications and Conflict, Vol. 23, No. 2, pp. 1-14, 2018.
- [12] Zengin Y, Naktiyok S, Kaygın E, Kavak O, Topçuoğlu E. An Investigation upon Industry 4.0 and Society 5.0 within the Context of Sustainable Development Goals. Sustainability, Vol.13, No. 5, p. 2682, 2021.
- [13] Pereira, A. G., Lima, T. M., Charrua-Santos, F., (2020). Industry 4.0 and Society 5.0: opportunities and threats. International Journal of Recent Technology and Engineering, 8(5), 3305-3308. DOI:10.35940/ijrte.D8764.018520
- [14] Roblek, V., Meško, M., Bach, M., P., Thorpe, O., Šprajc P., The Interaction between Internet, Sustainable Development, and Emergence of Society 5.0. Data, Vol. 5, No. 3, p. 80, 2020.

## ECOLOGICAL IMPACT OF TELEWORK

Srdana Taboroši<sup>1</sup>, Biljana Maljugin<sup>1</sup>, Aleksandra Kovačević<sup>1</sup>

<sup>1</sup>Students at University of Novi Sad, Technical Faculty “Mihajlo Pupin”, Zrenjanin, Serbia  
e-mail: [srdana.taborosi@gmail.com](mailto:srdana.taborosi@gmail.com)

**Abstract:** Teleworking as a new method of work emerged with the development of information technologies, and it significantly popularized by the development of the internet. In addition to the socio-economic benefits of this method of work, due to the COVID-19 pandemic and the large number of companies that were forced to apply telework, the positive effects of this form of work on the environment have been noticed. By reducing commuting, lower consumption of work materials and electricity, teleworking can become more sustainable compared to conventional working methods if it is carried out in a planned and systematic manner.

**Key words:** teleworking, ecology, environment, sustainability.

### INTRODUCTION

The increasingly rapid advancement of technology and incorporation into human society has led to the transformation of the living and working environment. High-speed internet and portable devices have led to major changes in the performance of work and to the development of work at home. This form of work relies on intellectual work, unlike conventional methods, which are more often associated with physical work. People who work remotely are often referred to as “knowledge workers” [1], [2] and they do not need access to special tools or materials, but a large amount of information to do their job. Of course, this form of work also enables the performance of work at any location that provides satisfactory conditions.

This method of work has become increasingly popular in the last few decades and its benefits have been the subject of many researchers. The benefits of teleworking are various, from reducing utilities costs [3], greater organizational commitment [4], through better life-work balance [5], to better inclusion of people with disabilities [6].

More attention is paid to business results and the social aspect, and less to the environmental impact of teleworking. Some research confirms that teleworking reduces air pollution, reduces noise pollution and traffic congestion in and around urban settlements [7], but only with the advent of the COVID-19 virus and the global pandemic has the importance of the impact of teleworking on the environment developed.

### IMPACT OF TELEWORK ON THE ENVIRONMENT

The impact of employees on the environment can be observed through two aspects: impacts related to commuting and travel and the impact related to resource consumption (electricity, water, paper, equipment, etc.) [8]. Commuting to work results in the emission of harmful gases into the atmosphere, the consumption of non-renewable fossil fuels, pollution, noise, stress and traffic accidents. In many urban areas, car travel is the most common form of transport, and it is natural that these are the most harmful pollutants. As remote employees do not have to commute, it is logical that they are smaller consumers of fossil fuels and that they cause less pollution by emitting harmful gases, but this is true only if remote employees work from home or in the space where they live. Certain remote employees often use the co-working spaces where they stay while working, whether it is required by the company they work for, which does not have offices in that area, or they choose so because they do not want or do not have the conditions to work from home. In this case, remote employees still use some kind of transportation and commute to these coworking spaces. According to the authors [9], on average, fuel consumption is 17% lower on those days when employees are allowed to work remotely, as well as that remote employees choose on average 30% of their activities, such as shopping or leisure, to do closer to home and on thus reducing mileage.

When it comes to resource consumption, in many developed countries the workplace is one of the largest consumers of energy and resources [8]. This can be a problem at the national level for countries

seeking to reduce greenhouse gas emissions that are signatories to the Paris Agreement. In this case, it is natural to conclude that remote employees are responsible for lower energy consumption compared to corporate offices.

It is unrealistic to expect teleworking to completely replace the conventional method of work, nor to consider that the motivation of environmental protection can be crucial to teleworkers. It is much more pragmatic and sustainable to look at the benefits that telecommuting brings primarily to the organization and the individual, such as better work-life balance, greater job satisfaction and increased productivity [10]. Companies that hire employees remotely have the opportunity to outsource their employees, and this allows them to hire people they have not been able to do so and thus include people with disabilities, single parents or people abroad. In this way, the company becomes more competitive.

## **ECOLOGICAL EFFECTS OF TELEWORK DURING COVID-19**

During the COVID-19 pandemic, many companies were forced to use the method of teleworking to protect their employees and to some extent to continue their business. Until then, teleworking developed slowly and gradually, but in late 2019. and early 2020., most companies were practically forced to let their employees work from home, whether they had previously considered teleworking as a way to work for their company or not.

It is generally accepted that well-organized teleworking has some potential to reduce energy consumption and emissions [11]. Many authors deal with the effects of teleworking and its impact on business, the environment, but also on the growth and success of companies [12] find that, in addition to the importance of determining the effects of teleworking, it is important that employees understand these effects and their potential, because that is the reason why it is difficult to successfully introduce this method of work.

The social benefits of teleworking are most commonly known, such as a better work-life relationship, greater job satisfaction, and organizational commitment [13],[4]. On the other hand, a lack of understanding of this method of work can also lead to business problems, such as social isolation [14] which can lead to reduced productivity and depression in employees. If the health aspect of teleworking is observed, employees may experience certain negative consequences such as cardiovascular problems or discomfort due to long sitting and reduced movement [15]. Not all employees are destined to understand, use and enjoy the benefits of teleworking due to differences in individual characteristics, not all employees have the same level of self-discipline, self-motivation and physical and technical conditions to complete the entrusted job, such as their own computer and quiet space for working. This implies that a large number of people, especially the lower socio-economic classes, perceive telework as very uncomfortable [16].

Environmental sustainability has been a very important topic in business in recent decades, because the global state of the environment has progressively deteriorated with the industrial revolution, especially in the middle of the 20th and the beginning of the 21st century. With the development of information technologies and the emergence of teleworking, research has emerged that examines the sustainability of this method of work in relation to the environment. Remote working really enables the reduction of traffic jams, reduces the emission of harmful gases by using passenger cars as the primary mode of transport [17], and with the adoption of laws that stimulate citizens to use bicycles and public transport, a positive impact on the environment can be expected [18].

An increasing number of studies show the positive impact of teleworking on the environment, especially on problems such as pollution [19], climate change [20] and energy consumption [9], and they show just how important it is to properly develop programs that would enable as many companies as possible to introduce this method of work into their business. In early 2020, when the World Health Organization categorized COVID-19 as a pandemic and advised the introduction of lockdowns, a large number of companies found themselves completely unprepared with an underdeveloped strategy and insufficiently trained management to move to teleworking as the primary method of pandemic work [21]. Such sudden changes in business have led to major problems in the implementation of the new method of work, and consequently in business as a whole. After several months of gradual adjustment of employees, as well as management, and after the abolition of restrictive measures in most

developed countries, a significant number of employees have refused to return to the in-office method of work and want to remain remote. There have been cases of employees resigning in order to find remote jobs, if current employers do not want to allow them to continue working from home after the abolition of lockdowns [22]. Thanks to the pandemic, many companies quickly had the opportunity to see all the advantages, but also the difficulties of this method of work, and the world's population was able to follow the effects of teleworking on the living environment.

Teleworking is environmentally friendly, although it cannot completely solve all the problems brought by commuting, significantly mitigates the consequences such as emissions, improves traffic safety because it reduces the amount of unnecessary traffic and reduces the need for transport, and directly insurance costs. As teleworking is directly responsible for reducing office space costs, it also reduces electricity consumption and office supplies. Very often this method of work is recommended in order to significantly reduce the socio-economic and environmental impacts of mobility in urban metropolises.

In order for teleworking to really contribute to the environment, it is necessary to put emphasis on the energy efficiency of the space from which employees perform their work. Guerin [23] makes two recommendations on how teleworking can be systematized and thus really make it more environmentally efficient compared to in office work:

1. reduce office space by reducing in-office desks for teleworkers and creating a “hot desk” situation, and
2. teleworkers must ensure that their work space at home is as energy efficient as possible, which companies should support and compensate for the costs incurred on this occasion during the adjustment of the workplace.

In this way, employees are confident that they will spend less necessary resources such as work materials and electricity, which significantly contributes to reducing the environmental footprint of the individual and the company.

## **CONCLUSION**

With the emergence of the COVID-19 pandemic, teleworking has become widely accepted, but organizations still need to make some effort to adapt to make their method of work a truly viable option as opposed to current practice. Working conditions in some countries have been very extreme due to the introduction of movement bans, but Loia and Adinolfi [16] find that people's awareness of the environment and human negative impact on it has increased significantly when significant changes have been seen due to lack of free movement. This is perhaps most important in the process of introducing a new method of work, so that employees really understand the full impact of teleworking, that management empowers its employees to successfully overcome difficulties, to develop efficient ways of communication and thus reduce the negative impact on the environment. In this process, the Department of Human Resources has the most important role to communicate in an understandable way all benefits, including environmental, to employees at all organizational levels [24], [25].

## **REFERENCES**

- [1] Kling, R., Scacchi, W.: The web of computing: Computer Technology as Social Organization. *Advances in Computers*, 21, pp.1-90, 1982.
- [2] Drucker, P. F.: Implementing the effective management of knowledge knowledge worker productivity: The Biggest Challenge, In J. W. Cortada& J. A. Woods (Eds.), *The Knowledge Management Yearbook 2000-2001*, pp. 267-283, Woburn: Butterworth-Heinemann, 2000.
- [3] Egan, B.: Feasibility and cost benefit analysis. Paper presented at the International Telework Association Annual International Conference, Crystal City, VA, 1997.
- [4] Taboroši, S., Strukan, E., Poštin, J., Konjikušić, M., Nikolić, M.: Organizational commitment and trust at work by remote employees, *Journal of Engineering Management and Competitiveness*, 10(1), pp. 48-60., 2020.
- [5] Hilbrecht, M., Shaw, S. M., Johnson, L. C., Andrey, J.: ‘I’m Home for the Kids’: Contradictory Implications for Work–Life Balance of Teleworking Mothers. *Gender, Work & Organization*, 15(5), pp.454-476, 2008.

- [6] Kenyon, S., Lyons, G., Rafferty, J.: Transport and social exclusion: investigating the possibility of promoting inclusion through virtual mobility, *Journal of Transport Geography*, 10(3), pp.207-219, 2002.
- [7] Dwelly, T., Lake, A.: Can homeworking save the planet? How homes can become workspaces in a low carbon economy, London: The Smith Institute, 2008. Available at: <http://www.flexibility.co.uk/downloads/Canhomeworkingsavetheplanet.pdf>
- [8] Hopkinson, P., James, P., Selwyn, J.: The environmental impact of teleworking, *Proceedings of Telework 99 Conference*, Aarhus, Denmark, pp. 187-95, 22-24 September, 1999.
- [9] Zaharia, A., Diaconeasa, M.C., Brad, L., Lădaru, G.-R., Ioanăs, C.: Factors influencing energy consumption in the context of sustainable development. *Sustainability*, 11, pp.4147, 2019.
- [10] Pyöriä, P.: Managing telework: risks, fears and rules, *Management Research Review*, 34(4), pp.386–399, 2011.
- [11] Oltra, V., Jean, M.S.: Sectoral systems of environmental innovation: An application to the French automotive industry, *Technological Forecasting and Social Change*, 76, pp.567–583, 2009.
- [12] Sandberg, J., Targama, A.: Shared understanding: The basis for collective competences and its development, In *Managing Understanding in Organizations*, SAGE: London, UK, pp. 89–108, 2007.
- [13] Dima, A.M., Tuclea, C.E., Vrânceanu, D.M., Tigu, G.: Sustainable social and individual implications of telework: A New Insight into the Romanian Labor Market, *Sustainability*, 11, pp.3506, 2019.
- [14] Toscano, F., Zappalà, S.: Social isolation and stress as predictors of productivity perception and remote work satisfaction during the COVID-19 pandemic: The Role of Concern about the Virus in a Moderated Double Mediation, *Sustainability*, 12, pp.9804, 2020.
- [15] Golden, T.D.: Avoiding depletion in virtual work: Telework and the intervening impact of work exhaustion on commitment and turnover intentions, *Journal of Vocational Behavior*, 69, pp.176–187, 2006.
- [16] Loia, F., Adinolfi, P.: Teleworking as an eco-innovation for sustainable development: Assessing Collective Perceptions during COVID-19, *Sustainability*, 13, pp.4823, 2021.
- [17] Baruch, Y.: The status of research on teleworking and an agenda for future research. *International Journal of Management Review*, 3, pp.113–129, 2001.
- [18] Harpaz, I.: Advantages and disadvantages of telecommuting for the individual, *Organization and society. Work. Study*, 51, pp.74–80, 2002.
- [19] Mekonnen, M.M., Pahlow, M., Aldaya, M.M., Zarate, E., Hoekstra, A.Y.: Sustainability, efficiency and equitability of water consumption and pollution in latin america and the caribbean, *Sustainability*, 7, pp.2086–2112, 2015.
- [20] Lundgren, K., Kjellstrom, T.: Sustainability challenges from climate change and air conditioning use in urban areas, *Sustainability*, 5, pp.3116–3128, 2013.
- [21] WHO (World Health Organization), WHO Director-General’s Opening Remarks at the Media Briefing on COVID-19, 11 March 2020, WHO: Geneva, Switzerland, 2020.
- [22] Melin, A., Egkolfopoulou, M.: Employees are quitting instead of giving up working from home, 2021. Available at: <https://www.bloomberg.com/news/articles/2021-06-01/return-to-office-employees-are-quitting-instead-of-giving-up-work-from-home>
- [23] Guerin, T. F.: Policies to minimise environmental and rebound effects from telework: A study for Australia, *Environmental Innovation and Societal Transitions*, 39, pp.18–33, 2021.
- [24] Reina, R., Scarozza, D.: Human resource management in the public administration. In *Organizational Development in Public Administration*, Decastri, M., Battini, S., Buonocore, F., Gagliarducci, F., Eds.; Palgrave Macmillan: London, UK, pp. 61–101, 2021.
- [25] Torre, T., Sarti, D.: Into smart work practices: Which challenges for the HR department? In *Working in Digital and Smart Organizations*, Ales, E., Curzi, Y., Fabbri, T., Rymkevich, O., Senatori, I., Solinas, G., Eds.; Palgrave Macmillan: London, UK, pp. 249–275, 2018.



## ANALYSIS OF OPPORTUNITIES FOR PRODUCTIVITY IMPROVEMENT OF DOMESTIC ENTERPRISES

Biljana Maljugić<sup>1</sup>, Srdana Taboroši<sup>1</sup>

<sup>1</sup>Students at University of Novi Sad, Technical Faculty "Mihajlo Pupin", Zrenjanin, Serbia  
e-mail: [biljanamaljugic28@gmail.com](mailto:biljanamaljugic28@gmail.com)

**Abstract:** Modern business and Industry 4.0, confirm the need for innovative action and the acquisition of new knowledge in order to improve productivity and competitiveness. In order to improve the placement of the domestic economy in the global environment, due to hyper-competition, domestic companies must primarily adapt the ways of managing modern techniques and methods modeled on the best examples from business practice. Knowledge management, quality management and marketing management are not sufficiently present in the business of domestic companies. Low level of productivity and technological equipment confirms the lack of knowledge and inadequate management, which results in unsatisfactory competitiveness.

**Key words:** global market, competitiveness, industry 4.0, knowledge, productivity.

### INTRODUCTION

In the conditions of modern global business and Industry 4.0, business productivity is based on knowledge productivity. The technological integration and digital connectivity of the global market requires efficient availability and exchange of information. The importance of new information is recognized in the timely needs and requirements of the market as well as in the exchange of information within the business organization. Increasing business productivity, which improves the competitiveness of business organizations, is achieved through the application of new technologies. The production capacity of the company is increased by the implementation of new technological solutions. At the same time, the use of human labor is decreasing and in the long run, according to Đorđević et al. [1, p.64] operating costs per unit of product are reduced. Observing domestic companies in the Republic of Serbia, one notices the necessity of new knowledge in the application of modern management methods and techniques, above all, but also in educational and training investments in human resources as well as investing in new technologies and the need for new staffing solutions. Owners of domestic capital, in order to succeed and survive in a turbulent market due to rapid technological and economic changes - the crisis and increasing competition, must direct their potential in the direction of change, knowledge acquisition and implementation of new technological solutions.

In the era of Industry 4.0. the speed with which countries accept new ideas enables prestige in the market, which in turn gains in importance for improving competitiveness. In innovation, Germany is known as the first country in the world. Then comes the USA, and in third place Switzerland. Innovation also means the speed of technology development. Rapid development and prestige are conditioned by the factors that determine the country's ability to innovate, which start from the quality of education and today the necessary application of information and communication technologies (IKT) [1, p.64]. The quality of business processes, ie the productivity of companies in modern business is based on the productivity of knowledge, which is the starting point for meeting the requirements of the business aspect. According to Đorđević, Čoćkalo [2, p.21], the business aspect of quality implies increasing efficiency, reducing costs, increasing productivity, increasing profits and long-term survival of the company.

### COMPETITIVENESS IN THE GLOBAL ENVIRONMENT

Newly industrialized countries are increasingly participating in the global economy. The success of the BRICS countries has confirmed that by investing in new technological solutions and innovative actions, it is possible to create and achieve competitiveness in the world's first and leading economies, such as the USA, Japan and Germany. Hyper-competition according to Kotler [3, p.30] describes the

current state of the global economy. The basic competitiveness requirements of the Global Competitiveness Index 4.0 are the following groups of indicators [4, p.61]: **1. Environment** - analysis of indicators: institutions, infrastructure, ICT acceptability and macroeconomic stability; **2. Human capital** with indicators: health, skills; **3. The market** includes the following indicators: product market, labor market, financial system and market size; **4. Innovation and ecosystem** with indicators: business dynamics, innovation capacity. The most significant areas of change in global transformation in relation to Industry 4.0, according to the recommendations of experts are [4, p.62]: 1. Agile management, 2. Innovation and productivity, 3. Merging technologies, 4. Needs for business leaps, 5. Needs for jumps in relation to existing jobs and skills, 6. Improving ethical action and identity. According to the World Economic Forum, ten things that the state administration should pay attention to are: that competition is not a luxury, investing in people is good for social and economic development, openness remains a fundamental factor in developing competitiveness, an open economy must deal with social protection, creation and innovation of ecosystems goes beyond research and development, technology creates development and prosperity in combination with other factors, institutions are still important, infrastructure and financial system are also important, in times of constant change it is necessary to be constantly agile and achieve unity sustainability and development of the country is possible only with proactive action [4, p.62]. The pillars of the evaluation of the Global Competitiveness Index have been improved in proportion to Industry 4.0 in relation to the previous methodology. IGK v4.0 is structured through 12 major drivers of productivity or as experts call them “pillars” where their impact on economic growth will increase as the effects of the fourth industrial revolution spread. The idea links the new methodology to the growing impact of ICT on economic development and that the transfer of knowledge and technology can reduce the time it takes for underdeveloped economies to reduce the level of lagging behind developed economies. According to experts and based on data for 2019, it is concluded that for more serious applications of ICT, but also to encourage the use of innovative technologies, it is necessary to provide a combination of different factors that are not mutually substitutive such as efficient administration, physical infrastructure, positive attitude towards entrepreneurial behavior, human capital, incentive institutions. It is concluded that only a small number of countries have managed to provide appropriate conditions for faster development and application of innovative technologies [5]. The paper discusses the results of the Global Competitiveness Report World Economic Forum (WEF) for 2019. Due to the new economic crisis caused by the COVID-19 pandemic, the WEF survey on global competitiveness was not realized for 2020. WEF data for 2019 show that Serbia ranked **72nd** on the ranking list, which includes 141 country with an IGK value of **60.9**. The realized value of IGK in 2019 is unchanged compared to the previous one, but due to the progress made by certain economies: South Africa, Croatia, Vietnam, Azerbaijan, Armenia, Brazil and Jordan, the relative position of Serbia on the ranking list has worsened. The value of IGK was calculated in accordance with the new methodology of IGK 4.0, which was applied for the first time last year with a new interval, the value of the index now ranges from 0 to 100. The SEF report covers 141 economies, which is an increase for one country compared to previous year. Barbados, Gabon and Madagascar are included again, while Liberia and Sierra Leone are left out of this year's report [5].

**Table 1.** Ranking of the top 10 countries in the world according to competitiveness in 2018 and 2019.

<b>Country</b>	<b>Place in 2018.</b>	<b>Place in 2019.</b>	<b>The change according to 2018.</b>
USA	1	2	-1
<b>Singapore</b>	2	<b>1</b>	+1
Germany	3	7	-4
Switzerland	4	5	-1
Japan	5	6	-1
Netherlands	6	4	+2
Hong-Kong	7	3	+4
United Kingdom	8	9	-1

Sweden	9	8	+1
Denmark	10	10	-

Source: The Global Competitiveness Report 2018 and 2019 World Economic Forum, 1. The Report in 2018 covers 140 countries [4, p.61], 2. The Report in 2019 covers the 141st country [6].

According to the data of the World Economic Forum of the WEF [6] the achieved value of IGK of 84.8 points is the best position on the ranking list in 2019, which was occupied by Singapore, the USA is in second place with the value of IGK of 83.7 points. The biggest progress [5] from the economies at the top of the list was achieved by Hong Kong, which improved its ranking by four places and was on the third position, while the Netherlands and Switzerland are on the fourth and fifth place. The biggest positive change in rankings compared to the previous year was achieved by Azerbaijan with an improvement of 11 places, followed by Vietnam with a jump of 10 places on the list and Kuwait and Rwanda, which improved the ranking by 10 positions. The biggest deterioration in rank was achieved by Iran and India, which recorded a drop of 10 places compared to last year, while Georgia and Lebanon fell by eight places compared to last year's rank. China ranked 28th on the WEF list for 2019 (same as 2018), Russia 43rd (same as 2018), India 68th (-10), Brazil 71st (+1), South Africa 60th with +7 compared to 2018 [6].

### **COMPETITIVENESS OF THE ECONOMY OF THE REPUBLIC OF SERBIA**

The achieved results for the past period, ie the values of the pillars of Serbia's competitiveness in 2019, are noticeable in the increase of eight, and decrease, ie. the result is worse for the three pillars of the global competitiveness index, while for only one it is unchanged. The positive contribution of IGC values compared to last year was contributed by the pillars: Institutions, Infrastructure, Skills, Labor Market, Financial System, Market Size, Business Dynamics and Ability to Innovate, while the negative result was achieved by: ICT Adoption, Health and Goods Market. Without going into a more detailed analysis, the overall ranking is contributed by the rating of each pillar, which means that we need to work on improving and advancing all variables [5].

**Table 2.** Ranking of the countries of the Western Balkans according to competitiveness in 2019.

<b>Country</b>	<b>Place in 2018.</b>	<b>Place in 2019.</b>	<b>The change according to 2018.</b>
Bosnia and Herzegovina	91	92	-1
Montenegro	71	73	-2
Croatia	68	63	+5
North Macedonia	84	82	+2
Slovenia	35	35	-
Serbia	65	72	-7

Source: The Global Competitiveness Report 2018 and 2019 World Economic Forum, 1. The Report in 2018 covers 140 countries [4, p.61], 2. The Report in 2019 covers the 141st country [6]

The results in Table 2 show that Slovenia is still ranked 35th on the WEF rankings, Croatia improved by 5 and Northern Macedonia by 2 on the rankings, while Serbia -7, Montenegro -2 and Bosnia and Herzegovina -1 dropped significantly to lower positions in the competitiveness ranking list for 2019 compared to 2018.

### **KNOWLEDGE MANAGEMENT AND PRODUCTIVITY**

Authors in their paper Mašić, Dželetović and Nikolić [7, p.32], define Knowledge management - KM, quoting foreign authors, according to **Wiig** knowledge management means "*understand, manage and focus on building, updating and applying systematic, explicit and thoughtful knowledge, that is, to manage the processes of effective knowledge*", according to **Davenport**, it is "*the process of*

*acquiring, distributing and effectively using knowledge*". Knowledge management according to Mašić and Đorđević-Boljanović [7, p.32] implies the adoption of collective knowledge in order to achieve business goals of the company with the role of **Macintosh** "to ensure that people have the knowledge they need, where they need it and when they need it necessary", ie "the right knowledge, in the right place and at the right time". Observing business in modern conditions, the authors [8, p.122] in their paper find inspiration in the experience of Bill Gates and define that knowledge management is based on information technologies. These are the views expressed by Bill Gates back in 1999. that "knowledge management is nothing but management during information, obtaining the right information to those who need it so that they can react to it quickly." From the same source [8, p.122] „Gates points out that knowledge management is not really related to technology:„ *knowledge management begins with business goals and processes, as well as knowledge of the need to share information ... knowledge management is a mean to achieve the goal, which is to increase the intelligence of the institution, ie the IQ of the company, which includes the sharing of both previous and current knowledge ...* "".

Knowledge Management in a business organization, company, primarily implies the application of modern management methods and techniques. Marketing Management must be in the focus of management because the market becomes inclusive, ie social media reduces barriers in communication between companies and consumers. Horizontal consumer orientation is evident. Advice and recommendations are conveyed and exchanged by both businesses and consumers. The marketing environment in today's business is characterized by hyper-connectivity, where consumers move from awareness (*I know about the product*), to action (*I buy the product*) to representation (*I recommend the product*) [4, p.61]. The Quality Management System (QMS) and the application of the International Organization for Standardization (ISO) have the role of improving the quality of business organization management, product or service quality, in creating business excellence and world class products, business performance and competitive capabilities of the company in the international market. Accordingly, the ISO 9001:2015 the standard has brought improvements in the direction of risk management. Creating competitiveness and improving company productivity is achieved through adequate change management in the organization, quality management, innovative thinking and action, and standardized products of the highest quality. The ISO 56002:2019 innovation standard has found application in various business innovation activities. The ISO 31000:2018 [9] risk standard provides guidelines for risk management in any organization. It is considered necessary for implementation especially in the conditions of the new economic COVID-19 crisis as well as in the post-pandemic period.

## **EXPORT OF DOMESTIC PRODUCTS**

In the research conducted in Central Banat [10] in the period from December 2019. to August 2020., based on a sample of 80 surveys and the views of managers of domestic companies, it was found out how domestic companies achieve labor productivity. The research covers public and private companies, various industries specific to this region of Serbia. One of the research questions was: How do you increase productivity in your company, with the possibility for respondents to circle more than one answer, so that there are a total of 96 of the following answers [10]: 1) applying new knowledge **15** (16%); 2) application of information technologies **15** (16%); 3) introduction of new technologies **12** (12%); 4) research and development of new products or services **11** (11%); 5) improving the quality of existing products or services **40** (42%); 6) something else **3** (3%). According to managers, it is noticed that increasing productivity in domestic companies is mostly achieved by improving the quality of existing products or services (42%), then applying new knowledge (16%) and applying information technology (16%), introducing new technologies (12%), research and development of new products or services (11%). Basically, it is necessary to first acquire new knowledge. Today, ICT technologies are necessary for more efficient business: to monitor the work of competitors, market conditions, obtaining the necessary information, a new marketing concept. Industry 4.0 brings digitalized businesses that require the expertise and new skills of employees. After that, it can be discussed about improving the quality of existing products or services. Then an increase in productivity is achieved, with a smaller volume of labor, technologies that reduce waste and product

errors, and all together it leads to a reduction in costs. Better productivity and lower costs affect the creation of prices and sales of standard quality products at lower prices than the competition, which implies an increase in market competitiveness. The obtained results suggest that the productivity of knowledge is very little represented and that companies must work in that direction. It has been noticed that domestic companies do not sufficiently apply modern management methods and techniques, so for these reasons they cannot achieve an appropriate level of improving the productivity of knowledge, which directly affects the poor productivity of business. Furthermore, according to the results of the same research [10], the export of domestic products from Central Banat on the foreign market is performed in several countries. Regions and countries where domestic products are exported are presented in a table.

**Table 3.** Overview of countries where domestic products are exported from Central Banat

<b>Exporting countries</b>	<b>Answers</b>	<b>Percentage</b>
Hungary	5	5.62 %
Romania	8	8.99 %
Bulgaria	2	2.25 %
Albania	1	1.12 %
North Macedonia	8	8.99 %
Montenegro	6	6.74 %
Bosnia and Herzegovina	12	13.48 %
Croatia	5	5.62 %
Slovenia	5	5.62 %
Austria	3	3.37 %
Germany	7	7.87 %
France	4	4.49 %
Czechia	4	4.49 %
Slovakia	1	1.12 %
Sweden	1	1.12 %
Netherlands	3	3.37 %
Israel	2	2.25 %
Rusia	1	1.12 %
Bangladesh	1	1.12 %
Egypt	3	3.37 %
South Africa	1	1.12 %
Countries in the region	1	1.12 %
Neighboring countries	1	1.12 %
EU	3	3.37 %
Middle East	1	1.12 %

Source:[10]

Based on the tabular presentation of respondents' answers, it can be noticed that most domestic products are exported to the countries of the region, Bosnia and Herzegovina (13.48%), Macedonia (8.99%), then to neighboring countries, Romania (8.99%), Hungary (5.62%) and European Union countries, Germany (7.87%), France (4.49%) and the Czechia (4.49%).

According to the data of the Republic Statistical Office of the Republic of Serbia [11] Industrial production in the Republic of Serbia in June 2021. increased by 4.4% compared to the same month in 2020. Looking at the sectors, in June 2021, compared to the same month in 2020, the following trends were recorded: in the sector of Manufacturing - growth of 6.3%, in the sector of Electricity, gas, steam and air conditioning - recorded is a decline of 3.2%, and in the Mining sector - a decline of 2.6%. "Data on industrial production - by purpose groups, in June 2021, compared to June of the previous year, show that there was an increase in production: capital products, by 21.7%, intermediate products, except energy, by 6, 7%, non-durable consumer goods, by 2.4%, and while the decline was recorded in the production of durable consumer goods, by 2.7% energy, by 1.4% " [11, p.39]. Observing the

available data [12], the coverage of imports by exports is 78.1%, which is higher compared to the coverage in the same period last year because it was 72.0%. According to the regional coverage, the largest share in the export of Serbia had the Region of Vojvodina in the amount of 36.2%, followed by the Belgrade region 23.6%, the Region of Šumadija and Western Serbia 22.0%, the Region of Southern and Eastern Serbia 18.0%, and about 0, 1% of exports are unclassified by territories. The main foreign trade partners in exports were: Germany, Italy, Bosnia and Herzegovina, Romania and Hungary. Imports of goods took place from Germany, China, Italy, Turkey and Hungary.

With the countries with which it has a Central European Free Trade Agreement (CEFTA) on trade, a free trade region, Serbia has achieved a surplus of about one billion euros from the export of the following products: oil and oil products, cereals and cereal products, electrical machinery and appliances, iron and steel and road vehicles [13].

## IMPROVEMENT GUIDELINES

Necessary factors for the development of domestic companies as well as the domestic economy are technological equipment and commitment to advanced technology. Domestic companies must primarily opt for business directed towards technological progress and technological unification, because these are the requirements of Industry 4.0. The priority is to work on the formulation of products with a higher level of technological content directed towards exports. The application of modern information and communication technologies is implied in today's business environment, but according to the same authors, "*the base of business activity of domestic companies should be industry and products based on the processing industry.*" In support of this is the example of the path of development of all newly industrialized countries in the world. The imperative for all domestic companies is to improve the technical and technological basis. The fact is that the improvement of the IT basis of business affects the improvement of labor productivity and business [4, p.64].

Regardless of all the problems from the past, the transition and the economic crisis, the current results and the ranking of the domestic economy in the world, first of all companies should behave and direct their business in the direction of global dimensions and acceptance of changes. According to domestic experts [4, p.64], domestic companies should be adaptable and focus on innovation. To be successful, companies must work simultaneously to improve, expand and innovate. This means that it is necessary to constantly adopt new knowledge and work on the productivity of knowledge in the function of improving business productivity, the development of competitiveness. The process of innovation in the organization must include the entire business. In addition to product or service innovation, as well as given that innovation processes are organizational in nature, management systems and organizational structures need to be innovated. According to Čeha [14, p. 306] economic progress and development of the Republic of Serbia "*requires the need to develop a competitive economy based on knowledge, new technologies and innovation.*"

Social and community interests should be given priority. It all starts with management and management functions. Entrepreneurial behavior and entrepreneurial management need to be implemented. Some domestic leaders need to change their way of thinking, reduce the level of vanity and increase the level of knowledge. This specifically means applying modern techniques and business and management models modeled on other countries that have revitalized their economies. Entrepreneurial behavior is also recommended in the management of public companies. According to Drucker, the establishment of an entrepreneurial concept in public service institutions, as well as for success in the function of organization development, requires the following [15, pp.155-156]: "the role and mission of the organization must be precisely defined; the institution must have a realistic overview and reports on objectives; failure to achieve goals should be viewed as an indication that a particular goal was wrong, misplaced, or wrongly chosen; public service institutions should incorporate constant research into innovative opportunities into their business policies and practices." In order for institutions to be productive, innovative action is very important and necessary for the establishment of the entrepreneurial concept in public services [15, pp.155-156].

Modern organizations must be well designed in terms of organizational structure, so the reorganization of business functions and the proper systematization of jobs must be done. In addition to high unemployment, it is necessary to employ adequate staff for the positions needed in both public and

private companies. Reduce labor turnover in the private sector. Respect and motivate employees to work even better, keep them in the organization, thus creating an atmosphere for the development of new knowledge and experiences that increases the level of productivity, quality, competitiveness and reputation of the organization.

Small and medium enterprises are part of the economy with significant development potential [15, pp.161]. Due to their size and structure, they are more flexible to changes and adapt faster to changes. In addition to all incentive measures of the state, it is necessary to simultaneously work and invest in technological development, research and development, scientific research in all branches of the economy. Increase the level of innovation in state-owned enterprises and innovation in the private sector. Small and medium enterprises with a recommendation to join and associate in the foreign market. Increase the quality of products and services, work on quality and product differentiation and apply integrated management systems.

The author Bešić, in his paper [16, pp.183-184], states that the domestic economy is a leader in the region when it comes to the number of certified organizations in relation to ISO management standards. He finds logic in the size of the domestic economy in relation to other countries in the Western Balkans, but he notices insufficient representation of standards in relation to the total number of active companies in Serbia, as well as in relation to other countries in Southeast Europe: Greece, Romania, Bulgaria, Hungary and others. According to the same author, quality management, one of the key factors in the competitiveness of a modern organization, has been adopted by domestic executives especially those companies that are internationally oriented.

## CONCLUSION

Knowledge today directly affects productivity, business quality, product or service quality, marketing concepts in business practice, market placement and competitiveness. The level of knowledge of employees, especially managers, must be constantly improved. It is necessary for everyone in the organization, in addition to effectiveness, to accept responsibility for their activities. Contributing to the improvement of the work, organization and functioning of production processes creates development opportunities in the global environment. Investments in new technological solutions and professional training of employees in the direction of new technologies as well as knowledge management must be in the strategy of domestic companies. New knowledge is needed, but knowledge as a resource must be shared and stored within the organization, constantly improved. Knowledge is the strength of a company. The intellectual capital of the organization is invaluable for creating and realizing new ideas, innovation, innovative management in difficult times where it is necessary to overcome any crisis and adapt to change. Information about new market needs points to Marketing Management and subtle business. In addition, without knowledge there are no new innovations, no differentiated or better products, no productivity. Quality Management System - QMS and standardization of business, as well as products of standardized quality, are mandatory factors in doing business in the global market, which is of particular importance for increasing exports of domestic products.

## REFERENCES

- [1] Đorđević, D., Čočkalović, D., Bogetić, S., Bešić, C., Analiza konkurentnosti domaće privrede u globalnom tržišnom okruženju, XVII Međunarodna konvencija o kvalitetu - JUSK ICQ, pp.63-70, 2021.
- [2] Đorđević, D., Čočkalović, D., Upravljanje kvalitetom, Tehnički Fakultet „Mihajlo Pupin“, Zrenjanin, 2007.
- [3] Kotler, P., Caslione, J., Kaotika, Mate, Zagreb, 2009.
- [4] Đorđević, D., Čočkalović, D., Bogetić, S., Bešić, C., Analiza aspekta konkurentnosti domaće privrede u uslovima globalnih tržišnih promena, International Convention on Quality 2019 – ICQ 2019 – Proceedings, Beograd, pp. 60-64, 2019.
- [5] Tanasković, S., Ristić, B., Konkurentna pozicija Srbija u 2019. godini prema Izveštaju Svetskog ekonomskog foruma, Ekonomski fakultet Univerziteta u Beogradu i FREN, Fondacija

- za razvoj ekonomske nauke, Dostupno na: [www.fren.org.rs](http://www.fren.org.rs), Datum posete: 18.11.2019. u 20:30h
- [6] World Economic Forum, The Global Competitiveness Report 2019, [www3.weforum.org/docs/WEF\\_TheGlobalCompetitivenessReport2019pdf](http://www3.weforum.org/docs/WEF_TheGlobalCompetitivenessReport2019pdf), poslednji put pregledano: 05.08.2020. u 23:54h
- [7] Mašić, B., Dželetović, M., Nikolić, D., Menadžment znanja i konkurentna prednost: Kuda ide savremena teorija i praksa, Zbornik radova Ekonomskog fakulteta Brčko, Časopis Ekonomskog fakulteta Brčko, Volumen 12, Sveska 1, 2018.
- [8] Dželetović, M., Mašić, B., Nikolić, D., Nešić, S., Menadžment znanja i konkurentnost organizacije, UDK: 005.94, Pregledni rad, Poslovna Ekonomija, Business Economics, Godina X, Broj II, Str. 118. - 139., doi:10.5937/poseko12-12266
- [9] [ISO - ISO 31000:2018 - Risk management - Guidelines](https://www.iso.org/standard/65694.html), 2018., Dostupno na: <https://www.iso.org/standard/65694.html>, Datum posete: 21.06.2021.
- [10] Maljugić, B., Analiza aspekata kvaliteta poslovanja domaćih preduzeća u cilju unapređenja konkurentnosti, Master rad, Tehnički Fakultet „Mihajlo Pupin“ Zrenjanin, 2020.
- [11] Republika Srbija Republički zavod za statistiku, Mesečni statistički bilten, jun 2021., 10.09.2021., Dostupno na: <https://publikacije.stat.gov.rs/G2021/Pdf/G20213009.pdf>, Poslednji put pregledano: 16.09.2021.
- [12] Uvoz/izvoz 2021: Ovo su rezultati za prvih 5 meseci!, [1. jula 2021.](https://plutonlogistics.com/spedicija/uvoz-izvoz-2021-ovo-su-rezultati-za-prvih-5-meseci/), <https://plutonlogistics.com/spedicija/uvoz-izvoz-2021-ovo-su-rezultati-za-prvih-5-meseci/>, poslednji put posećeno: 16.09.2021.
- [13] Beta, Spoljnotrgovinska razmena Srbije u prvom polugodištu veća 24,1 odsto , 30.07.2021. 13:34, dostupno na: <https://www.danas.rs/ekonomija/spoljnotrgovinska-razmena-srbije-u-prvom-polugodistu-veca-241-odsto/>, poslednji put posećeno: 16.09.2021.
- [14] Čeha M., Uloga procesa unapređenja znanja u funkciji postizanja konkurentnosti domaćih preduzeća, Contemporary business and management Synthesis, 2015.
- [15] Sajfert Z., Đorđević D., Bešić C., Menadžment trendovi, Univerzitet u Novom Sadu, Tehnički fakultet „Mihajlo Pupin“ Zrenjanin, 2006.
- [16] Bešić, S., Razvoj modela za primenu atributa marketinga u cilju obezbeđenja konkurentnosti preduzeća, Doktorska disertacija, Tehnički Fakultet „Mihajlo Pupin“, Zrenjanin, 2019.



## ANALYSIS OF THE APPLICATION OF INTERNATIONAL STANDARDS IN BUSINESS PRACTICE

Biljana Maljugić<sup>1</sup>, Marija Matotek Andelić<sup>2</sup>

<sup>1</sup>Student at University of Novi Sad, Technical Faculty "Mihajlo Pupin", Zrenjanin, Serbia

<sup>2</sup>Technical College of Applied Sciences in Zrenjanin, Zrenjanin, Serbia

e-mail: [biljanamaljugic28@gmail.com](mailto:biljanamaljugic28@gmail.com)

**Abstract:** The application of international standards is an imperative for doing business in global environment. The importance of standardization is recognized in a better and wider market performance and in achieving the competitiveness of the company. Standardization in the Republic of Serbia in 2020 increased compared to the previous year, but the number of implemented standards is still insufficient to improve the competitiveness of domestic companies. Inadequate knowledge and insufficient application of international standards are present in the research conducted in domestic companies in Central Banat. Achieving business excellence requires quality management. By integrating international standards, the long-term development of the company can be discussed and planned.

**Key words:** standardization, quality management, quality aspects, ISO 9001

### INTRODUCTION

"Standardization means defining and prescribing constant requirements to be met by a product, service, process, management system in a certain period of time" [1, p.70]. Standardization creates catches for creating better price offers of equable products that enable the development of competitiveness in the global market. It is important to point out that standardization provides protection of health and safety of the population, material goods, protection of consumer interests, international exchange of information and goods [2, p.15]. The International Organization for Standardization (ISO) has set out the basic principles of international standards [3, p.14]: equality, voluntariness, market orientation, consensus and international character. The application of international standards ISO 9000 is a milestone in the study of quality phenomena. The standards have brought a different approach to the problem from reactive thinking in order to eliminate already made mistakes, to proactive thinking, i.e. preventing mistakes in future business. "The application of standards enables the perception and identification of potential causes of problems and the prevention of their occurrence in the future" [3, p.14].

### QUALITY AND COMPANY MANAGEMENT

Quality is defined as "a set of characteristics that are relevant for assessing the use value of a product / service or an activity" [4, p.238]. Modern business is characterized by quality as a category that encompasses and is observed from several approaches, i.e. aspects: technical, market and management [3, p.18]. Increasing competition in the international market, as well as doing business in a global environment, implies that the management of a business organization must take place through the implementation of the concept of Quality Management System (QMS).

Due to standardized documents, procedures and processes, the level of business quality is improved in performing business activities, which achieves competitiveness in the market. Business quality implies a management approach, it is imperative in performing all business functions. Based on that, we discuss the quality of business, which includes three dimensions: market, business and social. Market aspect of quality includes - customer satisfaction, usability, market position, competitive advantage. The business aspect of quality means increasing efficiency, reducing costs, increasing productivity, increasing profits, long- term survival. The social aspect includes protection of human health, protection of the environment, saving natural resources and protection of consumers. An excellent company must meet all the above aspects of business quality [3, p.21]. In order to achieve the goals of excellence, it is necessary, according to Heleta, for the company to ensure the simultaneous achievement of all three aspects of quality, namely: "Marketing aspect of quality, which includes a

technical aspect related to product performance; Business aspect, which includes organizational aspect of quality and Social aspect, which includes moral and ethical aspect of quality" [3, p. 20].

### **ISO 9001: 2015 AND STANDARDIZED MANAGEMENT SYSTEMS**

ISO 9001: 2015 standards are embedded in the concepts of QMS quality management systems, in the Japanese Total Quality Management - TQM model of Business Excellence, which was crowned with the Deming Award, in the American Malcolm Baldrige Quality Award and the European Business Excellence Model European Foundation for Quality Management - EFQM.

An important role in the quality management system belongs to the PDCA methodology, one of the methodologies of continuous quality improvement. In the general case, the TQM, Six Sigma, ISO 9001 methodologies serve to solve problems during quality improvement, focusing on reducing the production costs and maintaining optimal production flow [2, pp.137-138]. The methodology of continuous improvement of business quality Plan-Do-Check-Act is a model of continuous improvement of organization management. PDCA is a cyclic process which means: Planning, i.e. determining the nature of the problem, the possibility of change, improvement; Execution, implementation of these changes; Verification, assessment of the impact of changes; Acting as necessary modifications before the new process. The PDCA cycle is built into the basis of the model of international standards ISO 9000: 2000 and supports the basic management model: planning, organizing and control with feedback, which means that the information from the control phase is the entrance to the next planning cycle [2, pp.137-138].

ISO 9001: 2015 enables a higher level of communication between the existing management standards, especially the ISO 9000, ISO 14000, ISO 18000 series [1, pp.72-73]. The new version of the 2015 standard still insists on a process approach to managing the organization. The content of the ISO 9001: 2015 standard has the following elements [5]: 1. scope and subject, 2. normative references, terms and definitions, organization context, leadership, planning, support, operations, performance evaluation, improvement. The standard model defined this way strives to be harmonized with the concept of TQM, it contains similar elements as the European EFQM. The basic goals of the new version of the standard in 2015 are the following [6, p.67]: To ensure the stability of the basic requirements of the standard in the next 10 years; Focus on process and result management; Improving the compatibility of ISO 9001 standards with other management standards; Achieving effective application of standards and conformity assessment.

IMS integrated management systems [4, p.51] integrate international standards for quality management (QMS), environmental management (EMS), employee safety management (OHSAS) and other standards, based on the application of the requirements of these standards. The quality management system is a basic starting point for upgrading other standards for managing business segments and is recommended in order to achieve business excellence. Partial management systems are represented by individual companies to achieve certain satisfaction according to the requirements of stakeholders, such as meeting customer requirements for certain product quality, then the society's in environmental issues, food safety in the supply chain, satisfaction of the employees in the protection, safety and security at work section, social responsibilities, information security and other satisfaction of requirements. According to the revision of the ISO 9001: 2015 standard, the following table presents only some of the standardized management systems according to the requirements of stakeholders [2, pp.188-189].

**Table 1.** Standardized Management Systems valid edition

<b>Number</b>	<b>Name</b>	<b>Standard designation: Valid edition</b>	<b>Interested party</b>
1.	<b>QMS</b> ( <i>Quality Management System</i> )	ISO 9001:2015	User
2.	<b>OH&amp;SMS</b> ( <i>Occupational Health and Safety Management System</i> )	OHSAS 18001:2007	Employees
3.	<b>SAMS</b> ( <i>Social Accountability Management System</i> )	SA 8000:2014	Employees

4.	<b>EMS</b> ( <i>Environmental Management System</i> )	ISO 14001:2015	Community
5.	<b>SR</b> ( <i>Guidance on Social Responsibility</i> )	ISO 26000:2010	Community
6.	<b>ISMS</b> ( <i>Information Security Management Systems</i> )	ISO 27001:2014	Management
7.	<b>SMS</b> ( <i>Security Management Systems for the supply chain</i> )	ISO 28000:2007	Partners

Source: [2, pp.188-189]

The **ISO 56002: 2019** standard is the standard for Innovation Management. It is a document that provides guidelines at a general level and can be applied in all types of organizations and all forms of innovation (products, services, models and methods and other). The document enables the establishment of ISO 56002: 2019, implementation, maintenance and continuous improvement of the innovation management system [7].

The **ISO 31000: 2018** standard is a standard for Risk Management. It provides guidelines and instructions for managing the risks that organizations face. The guidelines can be applied and adapted to any organization and its context. The ISO 31000: 2018 standard does not specify industries or sectors but is intended for and provides a common approach to the management of any type of risk. It can be applied in all business activities and decision making at all levels [8]. Business organizations that have implemented ISO 31000: 2018 in their business have better adapted to the situation of the sudden economic crisis due to the COVID-19 pandemic.

### **REPRESENTATION OF ISO STANDARDS IN THE REGION**

Increasing the number of certified companies, according to the experience of developed countries, affects the development of company competitiveness. The integration of standards will be faster and more efficient as it is enabled by the new version of ISO 9001. Given that, managers have the key role in decision making it is advisable to promote the concept of integrated management systems and achieving business excellence. The success of certification and its further application depends on the managers of domestic companies. In addition, according to Djordjevic et al. [9, p.69] the new structure of ISO 9001 "explicitly requires an active role and commitment of the company's management to the implementation of ISO standards". According to the research of ISO [10], Table 2 shows the number of implemented ISO 9001: 2015 standards in Serbia and the surrounding countries for 2020 and 2019.

**Table 2.** Implemented ISO 9001: 2015 standards in neighboring countries for 2020 and 2019

<b>Country</b>	<b>2020</b>	<b>2019</b>
Serbia	3092	2707
Croatia	2531	2715
Slovenia	1817	1761
Bosnia and Herzegovina	1145	935
Macedonia	629	502
Montenegro	220	163

Source: [11], [12]

According to the comparison of values in 2019, compared to 2020, the number of certificates in Serbia has increased. Observing regionally, Serbia has the greatest number of certificates compared to the former republics of SFRY. The following Table 3 presents the selected implemented standards according to the specification and purpose, as well as the values related to the number of standards in Serbia and the surrounding countries.

**Table 3.** Quantitative presentation of implemented certificates in Serbia and neighboring countries for 2020

<b>Country</b>	<b>9001:2015</b>	<b>14001:2015</b>	<b>22000:2018</b>	<b>27001:2013</b>
Bosnia and Herzegovina	1145	272	25	51

Croatia	2531	1138	54	302
Hungary	7030	2797	104	560
Macedonia	629	381	110	52
Montenegro	220	209	7	9
Romania	9935	5221	581	729
Serbia	3092	1629	187	351
Slovenia	1817	494	16	131

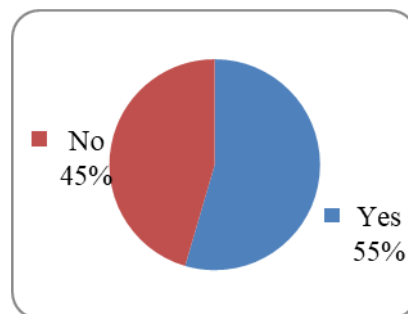
Source: [11]

Explanation: 1. **ISO 22000:2018** Food safety management systems -- Requirements for any organization in the food chain, 2. **ISO/IEC 27001:2013** Information technology -- Security techniques -- Information security management systems -- Requirements

**Table 3** shows that Serbia has the most individual certificates compared to the former republics of SFRY. The number of certificates in Serbia, as noted, is still insufficient compared to a larger number, compared to Romania and Hungary, or other European Union countries that conduct their business in the direction of business excellence.

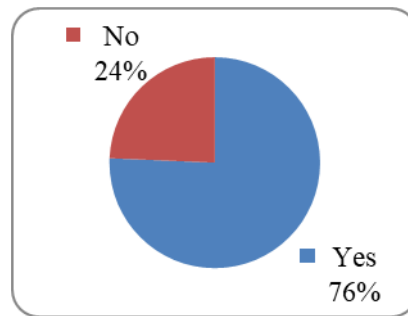
### ASPECTS OF BUSINESS QUALITY AND APPLICATION OF ISO STANDARDS IN CENTRAL BANAT

The research on the application of aspects of business quality in domestic companies in Central Banat was conducted from December 2019 to August 2020 [13]. On that occasion, 80 managers in private and state-owned companies were interviewed. The results of answers to certain questions related to aspects of quality and standardization are discussed in this paper. Attitudes of respondents to **RQ 1**. Can you conceptually define the phenomenon of business quality observed from three aspects of quality? are as follows: Three out of a total of 80 respondents, did not answer this question, 77 answered, of which 42 (55%) were affirmative answers, while 35 (45%) were negative.



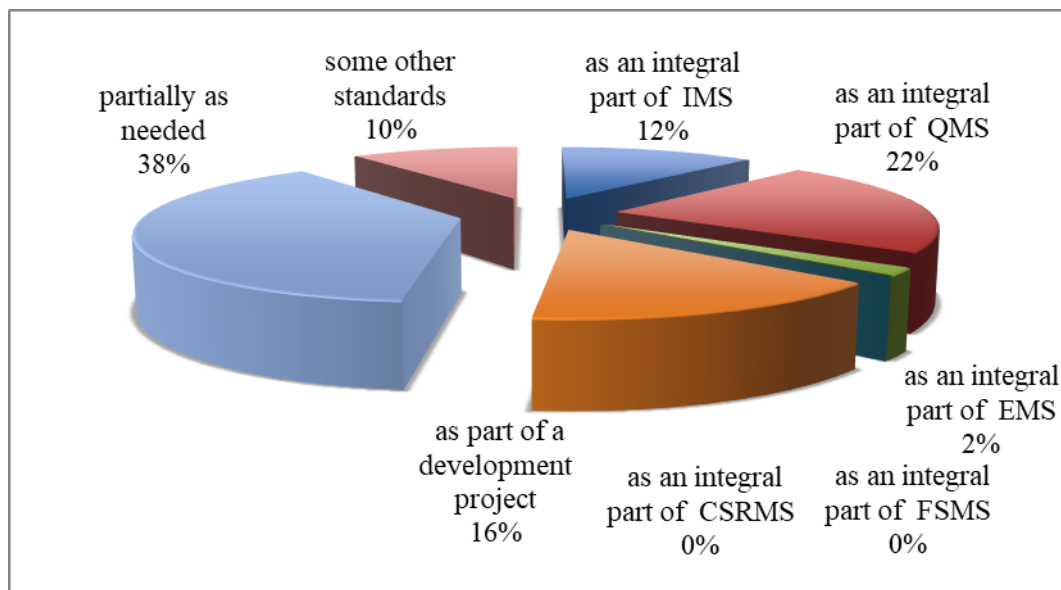
**Fig. 1.** Attitudes of respondents to the knowledge of the conceptual definition of the phenomenon of business quality observed from three aspects of quality

The next question was **RQ 2**. If the answer is yes, can you briefly define what in your opinion are the aspects of quality? 39 respondents answered. The exact definition of the phenomenon of business quality, with three aspects of quality: business, marketing and social, was confirmed by six respondents. Product quality in nine respondents is in the first place, with respect to standards in five answers, six respondents answered that consumer/customer satisfaction is in the first place, as well as employee satisfaction in two answers, followed by labor productivity, product price, financial success, profitability, efficiency and effectiveness of business, safety of employees and protection of consumers and the environment, compliance with agreed deadlines and speed and accuracy of delivery, are some of the aspects of business quality that respondents mentioned in their answers. To set **RQ 3**. Are aspects of business quality applied in your organization? Of the 80 respondents, 6 did not answer, 74 answered this question, of which 56 (76%) answered in the affirmative and 18 (24%) in the negative.



**Fig. 2.** Respondents' attitudes about the application of quality aspects in the organization in which they are employed

**RQ 4.** If the answer is yes, explain how: This question was answered by 58 respondents, and the answers on how to apply aspects of business quality according to the views of surveyed managers are as follows: as an integral part of IMS 7 (12%), as an integral part of QMS 13 (22%), as an integral part of EMS 1 (2%), as an integral part of FSMS 0 (0%), as an integral part of CSRMS 0 (0%), as a part of development projects 9 (16%), partially, as needed 22 (38%), the rest, i.e. some other standards, six respondents (10%) listed the standards used in their organization, and the standards are: Part of GPP (DAP), ISO standards, HACCAP, GMP +, HAAL, Accreditation standard, as well as answers: the application of accepted company work procedures, there is an internal system of products, services and processes control, internal and external evaluation for the purposes of accreditation of the institution.

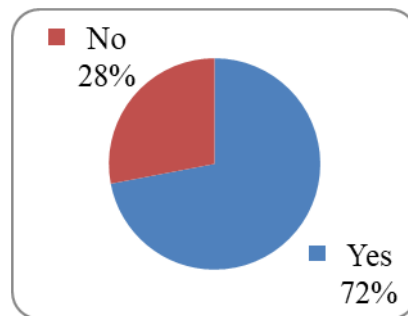


**Fig. 3.** Percentage presentation of respondents' attitudes on the manner of application of quality aspects in the organization in which they are employed

Based on the conducted research, it was found that a little more than half of the surveyed respondents, more precisely 55%, can conceptually determine the phenomenon of business quality observed from three aspects of quality. Confirmation of the application of quality aspects in domestic companies according to the answers of managers is 76%. It is noticed that most respondents apply quality partially, 38% as needed, which is wrong in the concept of Quality Management. Then as an integral part of QMS 22%, as a part of development projects 16%, as an integral part of IMS 12%, as an integral part of EMS 2%, which are essentially correct attitudes, i.e. orientations in accordance with international theory and practice. Other, i.e. other standards 10%, several managers listed the standards used in their organization, and the standards are: part of GPP (DAP), ISO standards, HACCAP, GMP +, HAAL, Accreditation standard, as well as answers: application of accepted work procedures of the company, there is an internal system of products, services and processes control, internal and external

evaluation for the needs of accreditation of the institution. It can be added that some respondents do not recognize the standards FSMS 0% and CSRMS 0%, which refer to management systems in food protection and corporate social responsibility. When we look at the total sum of correct answers QMS and IMS, which is 34%, it is obvious that it is almost equal to the incorrect ones. This can be interpreted so that half of the answers indicate lack of knowledge of the essence of the theory and practice of quality.

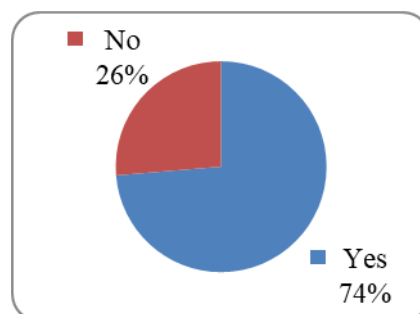
**RQ 5.** In your opinion, is there a significant link between the aspects of business quality and improving competitiveness? Out of 80 respondents, 75 answered this question by saying that there is a significant connection 54 (72%), and the opposite view was 21 (28%).



**Fig. 4.** Attitudes of managers about the existence of a significant relationship between aspects of business quality and improving competitiveness

**RQ 6.** If the answer is yes, can you state why 34 respondents answered this question. Most of the answers, i.e. in most of the answers, the managers have the same attitude that by increasing the quality of business, competitiveness also increases. Then, some agreed in their answers that the quality of business increases the efficiency of work, achieves product quality and creates prices in relation to the competition. There is a significant correlation, according to the respondents, between the aspects of business quality and improving competitiveness, 72%. In most of the answers, managers have the same attitude that increasing the quality of business increases competitiveness. Then, some agreed in their answers that the quality of business increases the efficiency of work, achieves product quality and creates prices in relation to the competition. While 28% of respondents did not agree with this statement, which is not recommended in modern business, when competitiveness is very difficult to achieve.

**RQ 7.** In your opinion, does the application of modern management methods and techniques affect the improvement of business efficiency? Out of 80 respondents, 76 answered this question, of which 56 (74%) said they do, and 20 (26%) said they do not..



**Fig. 5.** Attitudes of managers on the impact of the application of modern management methods and techniques on improving business efficiency

**RQ 8.** If the answer is yes, can you state why 31 respondents answered this question. In most of the answers, the respondents have the same attitude that the application of modern management methods and techniques affects the efficiency of business. Then, to achieve better productivity through application. Product quality and reduction of production errors are achieved. Business efficiency in the conditions of rapid technological changes and changes in the market requires the application of

modern management methods and techniques. The application of modern management methods and techniques affects the improvement of business efficiency in 74% of cases, and in 26% it is not the case. In most of the answers, the respondents have the same opinion that the application of modern management methods and techniques affects the efficiency of business. By applying the new management techniques, better productivity, product quality and the reduction of production errors are achieved. Several managers agreed that the application of modern methods reduces business costs, better manages the organization and business processes, and achieves better results. Such thinking is encouraging because it leads to the progress and development of the economy of this region.

**RQ 9.** In your opinion, what is the most important for achieving aspects of business quality (circle up to three answers): The possibility to give more answers resulted in 238 answers of the respondents, which are shown in the following Table 4.

**Table 4.** The most important elements for achieving aspects of business quality according to the views of managers of domestic companies

Number	Achieving aspects of business quality	Number of answers	Structure (%)
1.	product and / or service quality	67	28 (%)
2.	improving business productivity	33	14 (%)
3.	environmental protection	10	4 (%)
4.	speed of distribution	13	6 (%)
5.	security management in the organization	8	3 (%)
6.	good value for money	42	18 (%)
7.	improving customer satisfaction	42	18 (%)
8.	cooperation with the supplier	7	3 (%)
9.	cost reduction	13	5 (%)
10.	constant cost reduction	3	1 (%)
11.	something else	0	0 (%)
	<b>TOTAL</b>	<b>238</b>	<b>100 (%)</b>

Source: [13]

As the most important for achieving aspects of business quality respondents mentioned the quality of products and / or services (28%), then the good price- quality ratio of products (18%), as well as improving customer satisfaction (18%), followed by improving business productivity (14%), speed of distribution (6%), cost reduction (5%), environmental protection (4%), safety management in the organization (3%), cooperation with the supplier (3%), constant cost reduction (1%). In achieving competitiveness, domestic companies should focus on improving customer satisfaction, which is achieved through the productivity of knowledge, and results in the quality of products / services, good pricing and constant cost reduction.

## CONCLUSION

Managing a modern organization implies the implementation of the concept of quality for achieving a stable market position in participation in the global market. In order to achieve the goals of business excellence, it is necessary for a company to combine the simultaneous achievement of all three aspects of quality: marketing aspect - holistic approach, information management; business aspect for long - term survival, with emphasis on knowledge productivity and on implementation of international standards and social aspect - socially responsible business. Combined aspects of business are the concept of quality that contains all the necessary elements to create and maintain competitiveness, achieve business excellence and achieve world - class products, starting from meeting customer requirements, achieving customer satisfaction and improving the quality of the entire business [13]. In the domestic companies of Central Banat, based on the results of the research, it can be concluded that there is inadequate knowledge and insufficient representation of international standards in the field of quality management.

Modern management methods and techniques, i.e., Quality Management and IMS are phenomena that in the long run contribute to the development [14].

## REFERENCES

- [1] Bešić, C., Đorđević, D., Savremeni menadžment trendovi, Univerzitet u Kragujevacu, Fakultet tehničkih nauka u Čačku, Čačak, 2017.
- [2] Čočkalović, D., Đorđević, D., Upravljanje kvalitetom, Univerzitet u Novom Sadu, Tehnički fakultet „Mihajlo Pupin“ Zrenjanin, 2018.
- [3] Đorđević, D., Čočkalović, D., Upravljanje kvalitetom, Univerzitet u Novom Sadu, Tehnički fakultet „Mihajlo Pupin“ Zrenjanin, 2007.
- [4] Sajfert, Z., Đorđević, D., Bešić, C., Menadžment trendovi, Univerzitet u Novom Sadu, Tehnički fakultet „Mihajlo Pupin“ Zrenjanin, 2006.
- [5] ISO CD 9001 Requirements with guide for use, ISO, 2012.
- [6] Bešić, C., Đorđević, D., Korporativna društvena odgovornost, FTN, Čačak, 2015.
- [7] [ISO - ISO 56002:2019 - Innovation management - Innovation management system - Guidance](https://www.iso.org/standard/68221.html), 2019., Dostupno na: <https://www.iso.org/standard/68221.html>, poslednji put posećeno:19.09.2021.
- [8] [ISO - ISO 31000:2018 - Risk management - Guidelines](https://www.iso.org/standard/65694.html), 2018., Dostupno na: <https://www.iso.org/standard/65694.html>, poslednji put posećeno:19.09.2021.
- [9] Đorđević, D., Čočkalović, D., Bogetić, S., Bešić, C., Analiza konkurentnosti domaće privrede u globalnom tržišnom okruženju, XVII Međunarodna konvencija o kvalitetu - JUSK ICQ, pp.63-70, 2021.
- [10] [ISO - The ISO Survey](https://www.iso.org/the-iso-survey.html), <https://www.iso.org/the-iso-survey.html>, poslednji put posećeno 19.09.2021.
- [11] ISO, [1. ISO Survey 2020 results Number of certificates and sites per country and the number of sector overall.xlsx \(live.com\)](https://www.iso.org/standard/68221.html), poslednji put posećeno 19.09.2021.
- [12] ISO, [1. ISO Survey 2019 results Number of certificates and sites per country and the number of sector overall.xlsx \(live.com\)](https://www.iso.org/standard/65694.html), poslednji put posećeno 19.09.2021.
- [13] Maljugin, B., Analiza aspekata kvaliteta poslovanja domaćih preduzeća u cilju unapređenja konkurentnosti, Master rad, Tehnički Fakultet „Mihajlo Pupin“ Zrenjanin, 2020.
- [14] Maljugin, B., Radosav, D., Ljubojević, N., Taborosi, S., Business Quality of Domestic Companies in the City of Zrenjanin, X International Symposium Engineering Management and Competitiveness 2020 (EMC 2020) June 19-20, Zrenjanin, Serbia, pp. 82-88, 2020.



## PRODUCTION FLOW DIAGRAM OF PLEATED BLINDS

Dijana Tadić<sup>1</sup>, Maja Knežević<sup>1</sup>

<sup>1</sup>University of Novi Sad, Technical Faculty “Mihajlo Pupin”, Zrenjanin, Serbia  
e-mail: [dijana.tadic@tfzr.rs](mailto:dijana.tadic@tfzr.rs)

**Abstract:** The authors of the paper deal with the analysis of production efficiency, on the example of pleated blinds. The research lasted for three months in 2021, in the form of observing the production flow and recording the results of the performance of employees on a daily basis. Based on the collected, a diagram of the production flow was created, with the help of which the following are presented and connected: employees, their activities at work and infrastructure. The analysis of the achieved results provides insight into the efficiency of the organization, and creates the possibility of comparing the achieved results and the way of working with other companies, which are engaged in the same or similar activities.

**Key words:** analysis, efficiency, production, production flow diagram

### INTRODUCTION

During all seasons, people need to protect themselves from the sun's rays, but also from unwanted views of their home. Therefore, they carefully choose curtains, blinds or shutters. On the market today, pleated blinds are very attractive, and blinds made of pleated fabric, which, thanks to their simple but interesting decorative form, provide an elegant look to any interior.

The specificity of pleated blinds is reflected in the various possibilities of transmitting daylight and temperature. They can be made in non-standard shapes, such as triangles, trapezoids and fans. At the same time, they are distinguished by different ways of management: from top to bottom, from bottom to top, or in both directions. By combining these characteristics, very likable aesthetic products are created, the demand for which is constantly growing.

The research of the efficiency of the production of pleated blinds was performed in one company, whose headquarters are in the Central Banat District. According to the number of employees, gross income and value of funds, it is a medium-sized company. In the period of 3 months in 2021, production was monitored and the achieved results were recorded every day. The flow diagram presents the concept of production, which, together with the analysis of work performance, leads to the evaluation of efficiency.

### LITERATURE REVIEW

The production flow diagram, with its ability to show the activities, paths and order of execution, was suitable for the presentation and analysis of the organization of the production of pleated blinds. The main feature of this diagram is that it graphically, with the help of certain symbols, illustrates a process. Therefore, it is reflected in universality, which enables understanding to everyone.

The flow diagram is based on the decomposition of processes, which is one of the main features of the Lean Six Sigma methodology, and thanks to the peculiarity of visualizing processes, it is easy to determine the distribution of resources and its losses [5]. Therefore, the flow diagram is very often used due to its practical application [6]. And because of their flexibility and simplicity of production, many authors opt for this technique.

In the work of the author Hirsch [3], it can be seen how, with the help of production flow diagrams, the production of aluminum and aluminum products is presented. Jozić [4], on the other hand, based on the mentioned tool, presented the most important points of the plant for the production of construction sheet metal.

The author Stankov [7] also used the production flow diagram, thanks to which he presented a simplified version of mineral wool production. Tomašević [8] also used this schematic to emphasize the importance of food safety management, on the example of cooked sausages. The author Veličković [9] dealt with integrated management in the bakery industry, and in his work he gave an illustration of the flow diagram of frozen dough production. The author Živalj [10], worked on the development

of the HCCP system in cheese production, and with the help of this diagram, presented all the important steps in the process of its production.

## **METHODOLOGY**

This paper is divided into two parts. The first part includes a description of the production process, on the basis of which a flow diagram was obtained. Description of coverage, the most important characteristics of each factor in production. During the research, the course of the process was observed, which employee is engaged in which activity, how work tasks are performed, and which tool employees use. Based on the observed, the flow diagram represents, in summary, the complete production flow.

The second part consists of the results that the employees achieved every day. On a weekly basis, each operator takes a paper, with their name and surname. On paper, there is a table, of five rows, for each working day. Operators enter their work performance, is the number of units performed, depending on the activity they performed. If they changed jobs during the day, the operator should note this in the field provided for comments.

At the end of the working day, the production manager records the performance of each operator. This data is stored and compared from month to month.

By connecting the production flow diagram, with the results that employees achieve, an insight into the efficiency of the organization is created. By following the diagrams, further research can be focused on detecting waste in production, in terms of waste of time, excessive stocks and the like, the elimination of which would contribute to better efficiency.

## **DESCRIPTION OF THE PRODUCTION PROCESS**

The condition to start the production of pleated blinds is to create a work order. In addition to the desired dimension, the customer has the ability to choose the color, method of management and fixing. By entering this information into the system, an order is formed. Each entered information directly affects a number of parameters. Thanks to that, the order contains all the data that the operators need to make the desired product.

Dimensions affect the number and length of ropes; the color of the profile is directly related to the color of all accompanying components; the model depends on the way of management, and according to the desired way of fixing the blind, it is determined what will be packed with it.

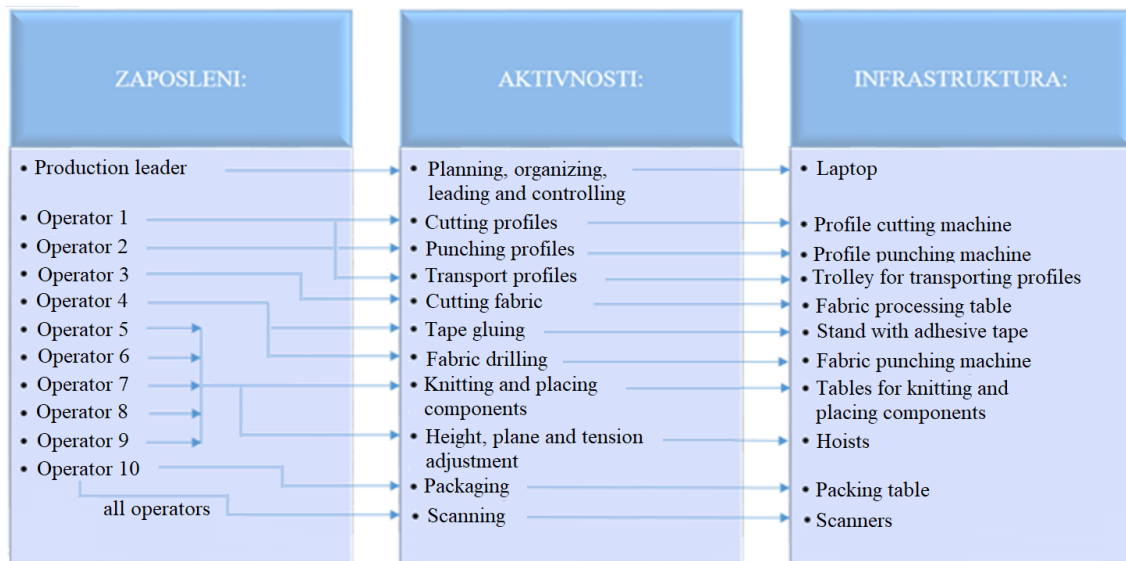
Before starting production, the production manager checks that all the necessary components are in stock. If the answer is negative, procurement is performed. If it is positive, it starts working.

### **Activities**

One part of the work order is taken over by the operator on the profile cutting, and the other on the fabric cutting. These operations are performed in parallel and represent the basis for the production of blinds. After cutting the profile, they are drilled. After these activities, but also every next one, the operators are obliged to scan the barcodes, provided for their position. The prepared profiles are placed in special carts, with the help of which, after filling, they are transported to the hall where they are paired with the fabric. Cut fabric, put on the shelf. After pairing with the profiles, the tape is glued along the edges, and then the fabric is drilled. Then, the fabric is connected to the profiles, and the accompanying components are placed. The next activity is performed by 5 operators (each for himself). This means that the operators pull the ropes through the holes and install the accompanying equipment. Then, a special device (hoist) is attached to the blind, which enables the blind to be stretched in accordance with the desired dimension. Final adjustments are made on this device. This includes the height of the blind, leveling and steering load. After that, the is placed on the shelf, as if ready for packaging. The last activity, before sending the product to the customer, is putting it in the box and attaching the fixing components. One of the listed positions employs one operator (except for the host). In case an operator is prevented from coming to work, the production manager assigns employees to other positions (at their expense) or directs two operators to perform some activity, so that they can return to theirs as soon as possible.

## Infrastructure

Figure 1 shows the employees engaged in the production of pleated blinds, their daily activities and the necessary infrastructure.



**Fig. 1.** Employees in production, activities and infrastructure

Every employee has their basic responsibility, but the company's policy promotes that all employees in production be trained for all positions. This enables the rotation of employees, the creation of insight into which employee is more competent for which position, and on the other hand, which operator is more responsible for which job.

The jobs that are performed in the company are directly related to the machines on which they are performed. All operators are required to undergo management training on them. In addition, employees borrow small tools, which are used in performing their work tasks.

## Models

Operators working on knitting and assembly of accompanying equipment are trained to produce 50 different models of pleated blinds. The basic division is: wall and roof. In addition to this division, blinds differ in the way they are governed.

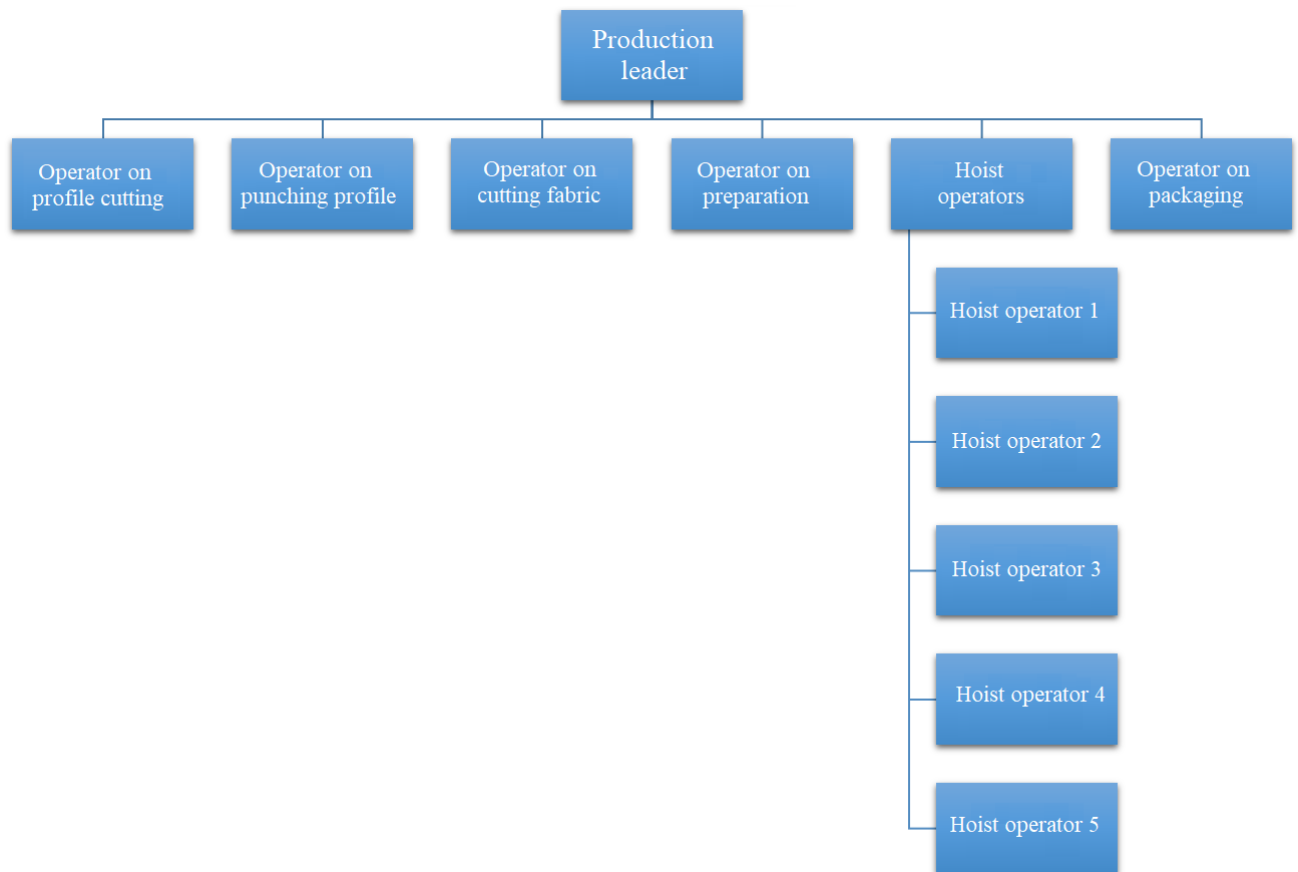
## Materials

The basic division of the fabric is into plush and double. Pleated materials have been used for centuries [2], and are considered the most profitable in terms of material processing.

Pleated fabrics have a wide application in the manufacturing industry, and mostly in the textile [1]. Accordingly, customers have at their disposal a wide range of colors and designs, which they combine with their choice, with the color of the profile.

## People

The organizational structure is designed so that with a small number of employees, it gets the optimal number of produced units. It is shown in Figure 3. On pleated blinds, 10 employees are engaged, led by the production manager.



**Fig. 2.** Organizational structure

### **Production flow diagram**

Based on the described, a flow diagram is given, which represents the concept of the entire production of pleated blinds, Figure 3.

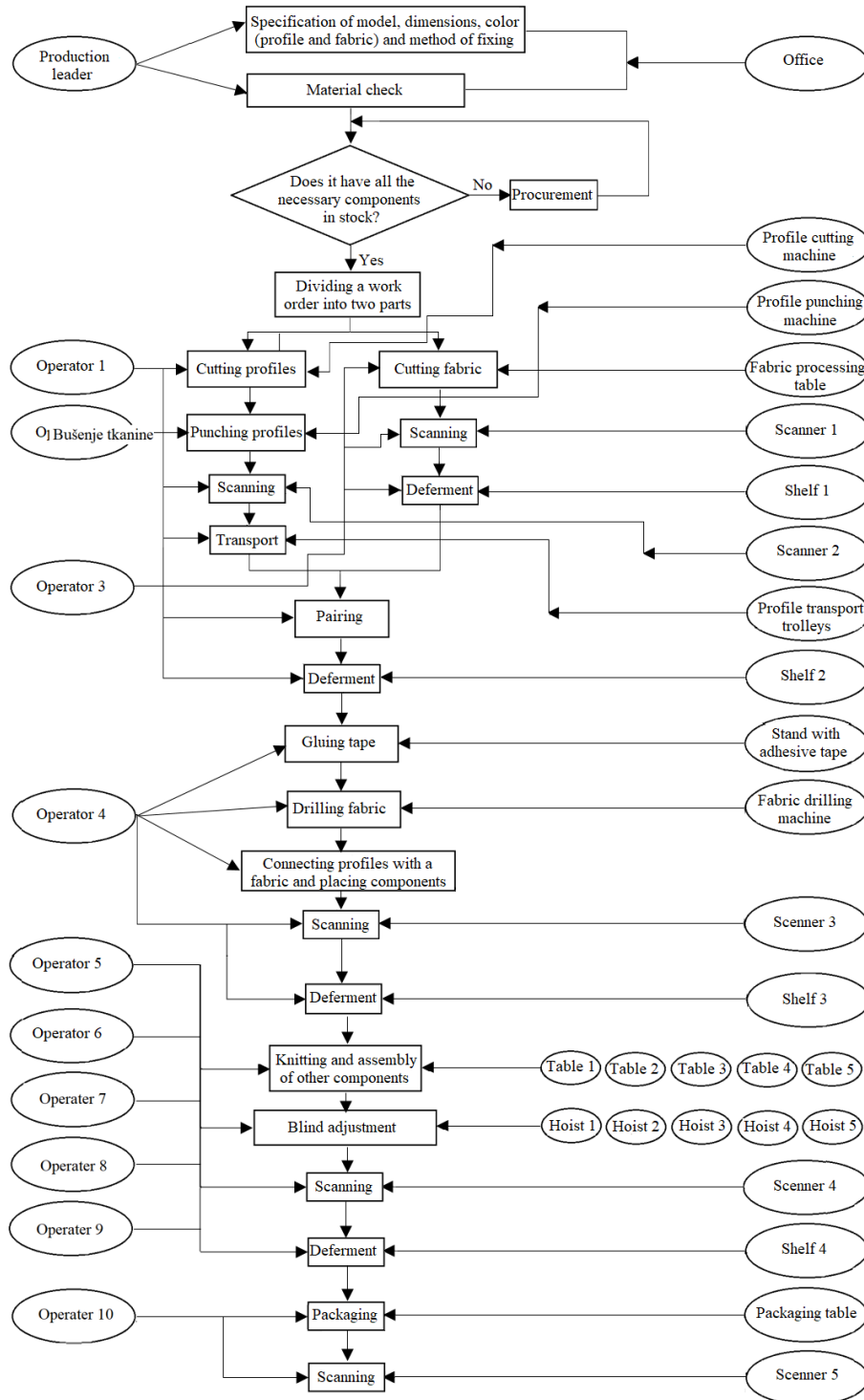


Fig. 3. Production flow diagram

## RESEARCH RESULTS

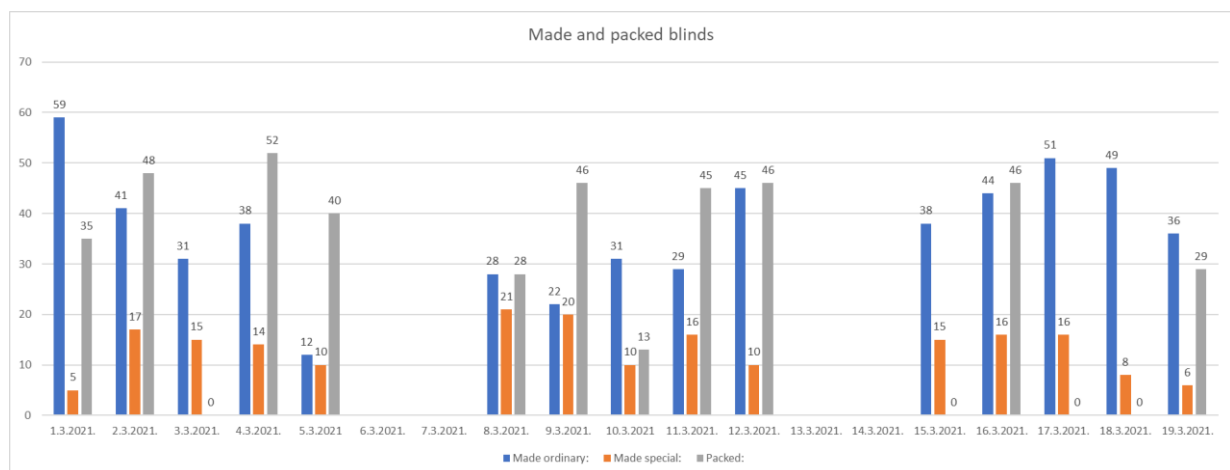
Production monitoring was performed for 3 months, in 2021. One part of the results is shown in a table, while the other is intentionally omitted, due to great similarity and repetition. There was no work on Saturdays and Sundays, so those fields were shaded, for easier records. The table shows the date, how many profiles were cut and drilled that day, how many fabrics were cut and prepared, how many blinds were assembled and packed, and the number of operators present. It was also recorded which employee was engaged in which position (which is not shown). The data in the form of a

summary indicate that two operators worked on the same activity (at the expense of another, temporarily suspended activity). The pace and organization of work are dictated by the operators who are working on the finishing of the blind - on the hoist. Since the models are very diverse, there are many variations in the way of assembly, as well as in the time spent. The complexity of blinds is measured according to the group to which they belong. There are ordinary and special models, which are shown in the table. If the operators work heavier models on the hoist for one or more days, the prepared material becomes saturated. Also, if a series of lighter models is encountered, the positions in preparation require reinforcement, and the operator is often withdrawn from the package or from the hoist, in order to establish balance. Also, if there is an accumulation of material, the operator switches to where there is a need to double the workforce. This means that if the working performance of the operator is in a position below the average, it is because the operator performed more jobs that day, and if the result is added up, the operator did not work alone.

**Table 1.** Part of the results achieved in production during 2021

Date:	Cut profiles:	Punched profiles:	Cut fabric:	Drilled fabric / ansemling:	Made ordinary:	Made specialy:	Total made blinds:	Number of operators on a hoist:	Packed	Σ operators:
1.3.2021.	80	76	62 + 22	70	59	5	64	5	35	10
2.3.2021.	82 + 12	63	60	66	41	17	58	5	48	10
3.3.2021.	60	50	57	56	31	15	46	5	45 + 24	10
4.3.2021.	48	40	50 + 30	50	38	14	52	5	52	10
5.3.2021.	45	20	47	52	12	10	53	6	40	10
6.3.2021.										
7.3.2021.										
8.3.2021.	38	27	50	38	28	21	49	5	28	8
9.3.2021.	68	35 + 38	35	68	22	20	42	5	46	10
10.3.2021.	52	20 + 22	56	45	31	10	41	6	13	10
11.3.2021.	74	64	50	55	29	16	45	5	45	10
12.3.2021.	78	37	35	40	45	10	55	6	46	10
13.3.2021.										
14.3.2021.										
15.3.2021.	54	26	51	57	38	15	53	5	36 + 44	10
16.3.2021.	29 + 35	31 + 18	69	65	44	16	60	5	46	10
17.3.2021.	68	28 + 36	72	63	51	16	67	6	27 + 30	10
18.3.2021.	57	42 + 33	27 + 32	57	49	8	57	6	0	9
19.3.2021.	37	19	42 + 22	51	36	6	42	6	29	10
Arithmetic middle	61	48	58	56	34	13	48	5	42	10
Σ	917	725	869	833	514	199	713	/	634	/

Observing the results achieved in three weeks, which are visible in the table, a diagram was made showing the number of blinds made each day, Figure 4.



**Fig. 4.** Blinds made and packaged in the observed period

According to the achieved performance and the number of operators working on the hoist, it can be concluded that each operator makes an average of 10 blinds. The results show that 2.5 times more ordinary blinds are made compared to special ones, and that 20% less is packed than is done. If it were

packed more efficiently, and equated with the made blinds, the delivery would be bigger and faster. Given that customers require the shortest possible delivery time, this could be the first step in improving efficiency. The diagram in Figure 6, shows the parallel cutting and drilling of the profile. Given that 22% more profiles were cut, it can be concluded that this activity takes place faster. It is necessary to improve the efficiency of profile drilling, ie to establish how this activity can be improved, and thus accelerated.

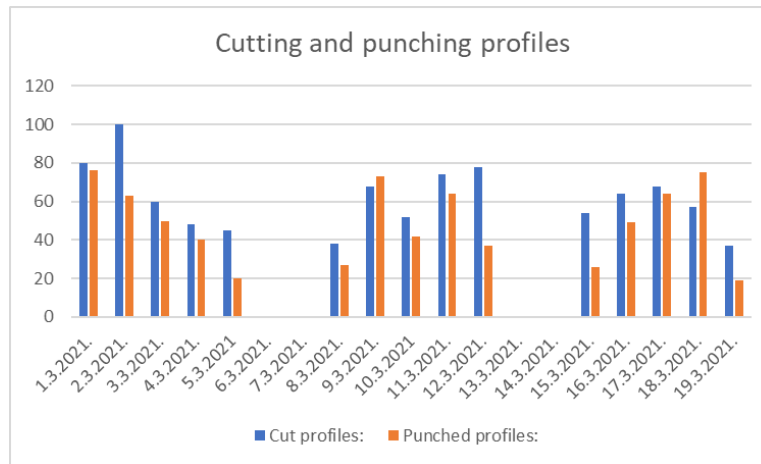


Fig. 5. Cutting and punching profiles

## DISCUSSION

The result of this research is reflected in several further guidelines, which can help other authors and production leaders:

1. The described production flow and the achieved results can be compared with other companies, in order to determine the efficiency. Based on that, some processes can be corrected and supplemented, with the aim of speeding up production. Also, one can compare the number of employed people with their results, and accordingly, determine where and why some of the losses are created.
2. With the growth of production, it is necessary to determine how many more people can be employed, and to be optimally distributed, because they are limited with business space. In some positions, several operators can work, independently of each other, while in some for now, only one can work. Such circumstances should be assessed and a “bottleneck” determined. Based on this information, a schedule or organization should be made.
3. The production manager makes the distribution, based on the knowledge of the qualifications / skills of employees and the complexity of individual activities - this is based on experience, decisions are made empirically. Mathematical modeling of the distribution of employees to positions would enable a kind of automation of the distribution and its independence from the presence / absence of the production manager - this is a possible extension of the research.
4. Production flow diagram, enables verification on the basis of prepared documentation, thanks to which deficiencies and omissions can be identified. This tool provides the ability to decompose the process, with an indication to more easily predict manufacturing errors, material waste, etc., but also opportunities to improve and enhance a process. Also, changes can be identified after a certain period, and progress can be established.
5. Based on the results of the research, it is possible to identify many shortcomings, the elimination of which would lead to improved efficiency.

## CONCLUSION

In recent years, highly sought after window decorations have been pleated blinds. Observing their production in one company, and recording the results achieved on a daily basis, lasted for three months, during 2021. A relatively small number of employees specialize in this type of production, but their results indicate good training and tact in their work. This merit can be attributed to the production leader, who faces challenges in an exceptional way and enables the smooth flow of production with his organization.

Based on the observed and recorded, a diagram of the production flow was made and the results achieved in the observed period were summarized. The results indicate an imbalance between activities such as cutting / drilling profiles and making blinds / packaging. In order to improve production efficiency, it is necessary to regulate this imbalance, ie to improve less advanced activities. The purpose of this paper is reflected in the analysis of efficiency and pointing out the shortcomings, which need to be eliminated in order to achieve even better results.

## REFERENCES

- [1] Florencia, A. (2021). Penerapan Teknik Pleated Pada Busana Pesta Evening Gown. *TEKNOBUGA: Jurnal Teknologi Busanadan Boga*, 9(1), 211-224.
- [2] Grömer, K., & Rast-Eicher, A. (2019). To pleat or not to pleat—an early history of creating three-dimensional linear textile structures. *Annalen des Naturhistorischen Museums in Wien. Serie A für Mineralogie und Petrographie, Geologie und Paläontologie, Anthropologie und Prähistorie*, 121, 83-112.
- [3] Hirš, A. M. (2017). *Alternativna način proizvodnje aluminija* (Doctoral dissertation, University of Zagreb. Faculty of Metallurgy).
- [4] Jozić, R. (2016). *Pogon proizvodnje jugođevinske limarije* (Doctoral dissertation, Josip Juraj Strossmayer University of Osijek. Faculty of Electrical Engineering, Computer Science and Information Technology Osijek. Department of Electromechanical Engineering. Chair of Electric Machines and Power Electronics).
- [5] Pavičić, M. (2021). *Poboljšanje procesa upravljanja podacima u proizvodnji* (Doctoral dissertation, University of Zagreb. Faculty of Mechanical Engineering and Naval Architecture).
- [6] Rukavina, M. (2018). *Alatiza upravljanje kvalitete* (Doctoral dissertation, Polytechnic Nikola Tesla in Gospić. Business department).
- [7] Stankov, S. P. (2013). Savremen način upravljanja procesom proizvodnje mineralne vune. *Chemical Industry/Hemijaska Industrija*, 67(2).
- [8] Tomašević, M. I. (2010). Upravljanje bezbednošću u proizvodnji hrane. *Poljoprivredni fakultet, Beograd*.
- [9] Veličković, J., Arsić, J., & Staletović, M. (2020). Integracija sistema menadžmenta u pekarskoj industriji Leskovac. *Trendovi u poslovanju*, 1(15), 44-54.
- [10] Živalj, M. (2019). *Razvijanje HACCP sustava u proizvodnji sira* (Doctoral dissertation, University of Split. Faculty of Chemistry and Technology. Division of Engineering and Chemistry).



## THE COMPARATIVE ANALYSIS REGARDING THE URBAN TRANSPORT TIMISOARA – LISBON THROUGH THE FASHION OF LINEAR

Patrick Stefanescu<sup>1</sup>, Luisa Izabel Dungan<sup>1</sup>

<sup>1</sup>University Politehnica Timisoara, Faculty of Mechanical Engineering, Timisoara, Romania  
e-mail: [stefanescupatrick@yahoo.com](mailto:stefanescupatrick@yahoo.com)

**Abstract:** The activity of exploitation of urban passenger transport means, must be organized and planned so as to lead to the efficiency of transport. Possible objective, if a well-defined system of indicators and analysis criteria is envisaged. The indicators and criteria used in the analysis of the activity of passenger transport units are of a qualitative and quantitative (operational) nature. Quality has been and is an important concern in passenger transport. Therefore, the way the activity of transporting people is qualitatively assessed depends on a series of indicators, namely: the average commercial speed, rhythmicity, punctuality, the loading degree of vehicles, the security of the movement, environmental protection. The quantitative assessment of the passenger transport activity takes into account the following indicators, namely: the route, the average daily course, the coefficient of use of the vehicle fleet, the performance, production, yield. The comparative analysis regarding the urban passenger transport took into account the most significant qualitative and quantitative indicators, an analysis that resulted in a statistical study over the duration of three years between the urban passenger transport activity in Portugal, the city of Lisbon, the Carris transport unit and the urban passenger transport activity in Timisoara, the transport company RAT Timisoara. The statistical analysis took into account the application of the Matlab Software Regression Method, and as methods of verification of the statistic hypotheses the statistical test  $t_n$ .

**Key words:** qualitative indicators, quantitative indicators, regression method, statistical test  $t_n$

### INTRODUCTION

Urban transport, and especially its main component of public passenger transport, is one of the most important functions of the locality, which ensures the unity and coherence of all its activities and can be considered the "barometer" of the level of development of the city, being an intrigue part of civilization, of the modern man.

Public passenger transport is in a continuous development [4] in support of this idea we can mention special platforms and programs, the travel validation system (ticketing), the fleet monitoring system (AVL)[3], the system of prioritisation of public transport.

The activity of exploitation of urban passenger transport means, must be organized and planned so as to lead to the efficiency of transport. Possible objective, if a well-defined system of indicators and analysis criteria is envisaged.

The indicators and criteria used in the analysis of the activity of passenger transport units are of a qualitative and quantitative (operational) nature.

Quality has been and is an important concern in passenger transport. Therefore, the way the activity of transporting people is qualitatively assessed depends on a series of indicators, namely: the average commercial speed, rhythmicity, punctuality, the loading degree of vehicles, the security of the movement, environmental protection.

The quantitative assessment of the passenger transport activity takes into account the following indicators, namely: the route, the average daily course, the coefficient of use of the vehicle fleet, the performance, production, yield.

The comparative analysis regarding the urban passenger transport took into account the most significant qualitative and quantitative indicators, an analysis that resulted in a statistical study over the duration of three years between the urban passenger transport activity in the city of Lisbon, the "Carris" transport unit and the urban passenger transport activity in the city of Timisoara, the transport company RAT Timisoara.

The statistical analysis took into account the application of the Matlab Software Regression Method, and as methods of verification of the statistic hypotheses the statistical test  $t_n$  [1].

## METHODS

The correlation method is that method of describing and analyzing statistical links between two variables, in the case of "simple correlation", or several variables, in the case of "multiple correlation".

The correlation method deals with the measure of the intensity of the statistical links between quantitative variables, associating correlation coefficients, determination coefficients, correlation reports and estimation errors.

The regression method provides relationship research pathways that link to a variable Y, called a dependent variable (endogenous variable) and one or more variables  $X_1, X_2, \dots, X_n$ , called independent variables (exogenous variables)

The regression equation or the exact relationship between the variable Y and the variables  $X_1, X_2, \dots, X_n$  in the form of an f function, that is:

$$Y = f(X_1, X_2, \dots, X_n) \quad (1.1)$$

defines a curve (in the case of linear a line) or a regression surface (in the linear case a plane or hyperplane) which gives an estimate of Y by means of the variables  $X_1, X_2, \dots, X_n$ .

The sought-after relationship is not, in general, accurate, but more appropriate is to consider a model of stochastic dependence, in which the random element appears in the form of additive errors, the regression equation becoming:

$$Y = f(X_1, X_2, \dots, X_n) + \varepsilon \quad (1.2)$$

where  $\varepsilon$  is a random error [1].

Regression curves are intended to "summarize" the information given by the "statistical cloud" associated with the double input (correlation) table of the two-dimensional distribution  $(x_i, y_j, n_{ij})$  through the scattering diagram containing next to each point  $(x_i, y_j)$  of the XOY plan and the partial frequency  $n_{ij}$  (or, respectively, the dispersion through segments of the distribution that replaces the  $n_{ij}$  with a segment of length proportional to the frequency, placed perpendicular to the XOY in  $(x_i, y_j)$ ) [1].

Modeling by simple linear regression consists in determining the adjusted regression ratios (with parameters estimated by the method of the smallest squares), i.e. those values that minimize the sum of the squares of the deviations of the observed values are taken as values of the parameters (coefficients of the regression lines)  $y_j$  in relation to the values  $\hat{y}_j$  corresponding to the points of the regression path sought (sum of the squares of the parallel differences at OY and OX respectively, of the statistical cloud point:

$$(x_i, y_j) \quad \begin{matrix} i=1, m \\ j=1, n \end{matrix}$$

to the corresponding points  $(x_i, \hat{y}_j)$ , respectively  $(\hat{x}_i, y_j)$  on the associated regression rights (D) and (D') respectively.

In the case of the linear regression model, the parameters of the model can be determined using *the method of the smallest squares*.

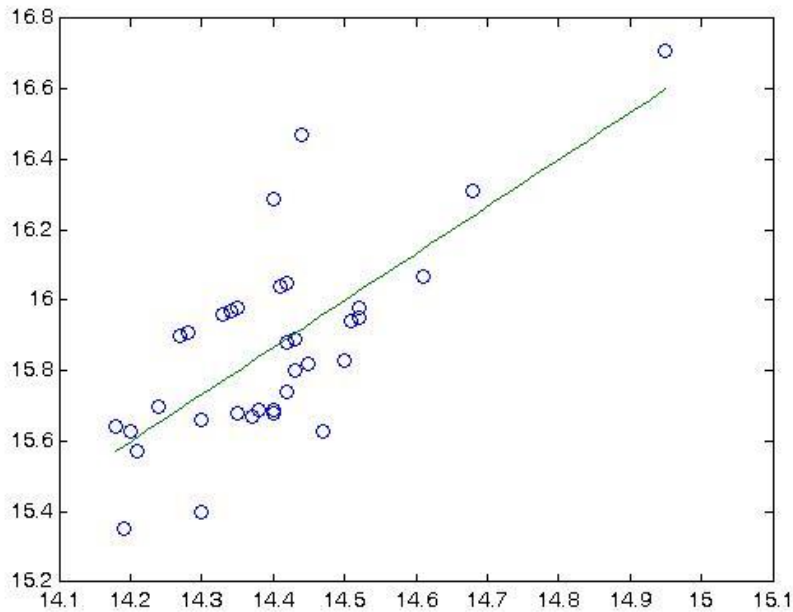
In the case of applying the multiple regression method one problem, which occurs after the estimation of the parameters is if, the common effect of all independent variables is statistically significant on the dependend variable. For this, methods or rules are used to verify statistical assumptions by applying statistical tests. One such significant test is the test  $t_n$ .

In the statistical analysis, qualitative and quantitative indicators with the following notation were used:

- Y represents the data from RAT Timisoara and X the data from Carris Lisbon:
- $X_1$  and  $Y_1$ - average commercial speed;
- $X_2$  and  $Y_2$ - number of the person transported;
- $X_3$  and  $Y_3$ - rhythmicity;
- $X_4$  and  $Y_4$ - the average daily course;
- $X_5$  and  $Y_5$ - production achieved;

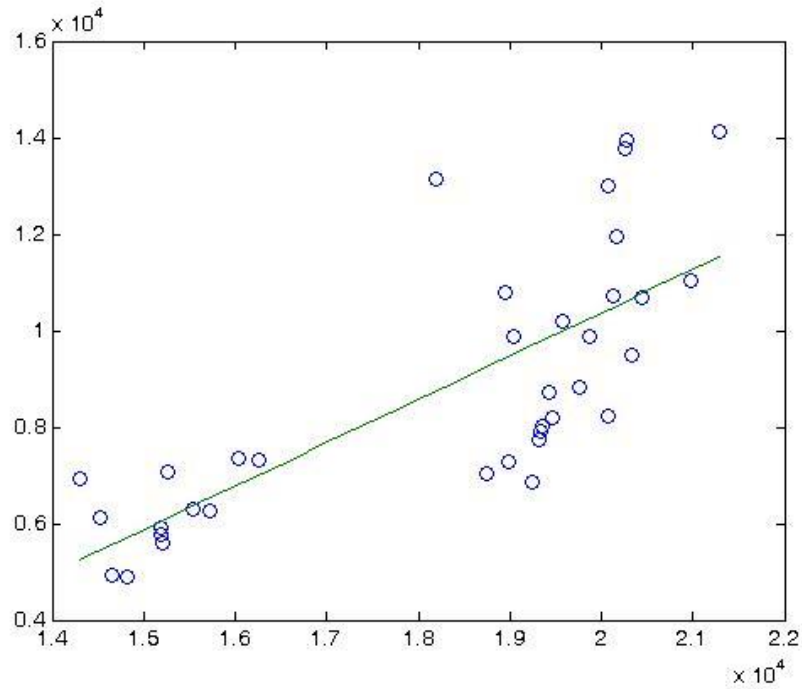
- $X_6$  and  $Y_6$ - the coefficient of use of the park;
- $X_7$  and  $Y_7$ - the performance performed;
- $X_8$  and  $Y_8$ - the degree of load;
- $X_9$  and  $Y_9$ -yield.

By applying the Regression Method and the mathematical operator Matlab, we obtained the following results plotted:



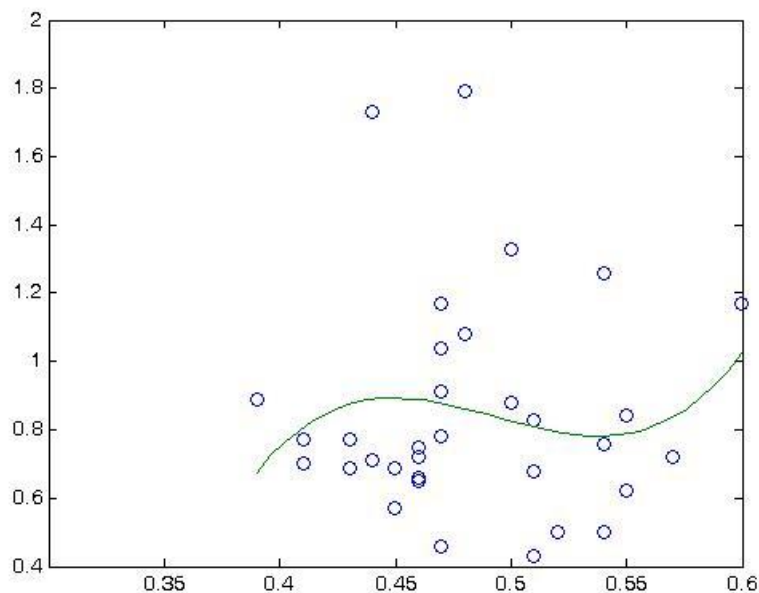
**Fig. 1.** The regression right of the average commercial speed indicator [2].

It is found in the graphic representation in Fig. 1 that the average commercial speed indicator for both Carris ( $X_1$ ) and RATT ( $Y_1$ ) is a straight line, with a level of confidence of 84% and which presents an upward trend, a beneficial element in improving passenger transport [2].



**Fig. 2.** The right regression of the indicator the number of people transported [2].

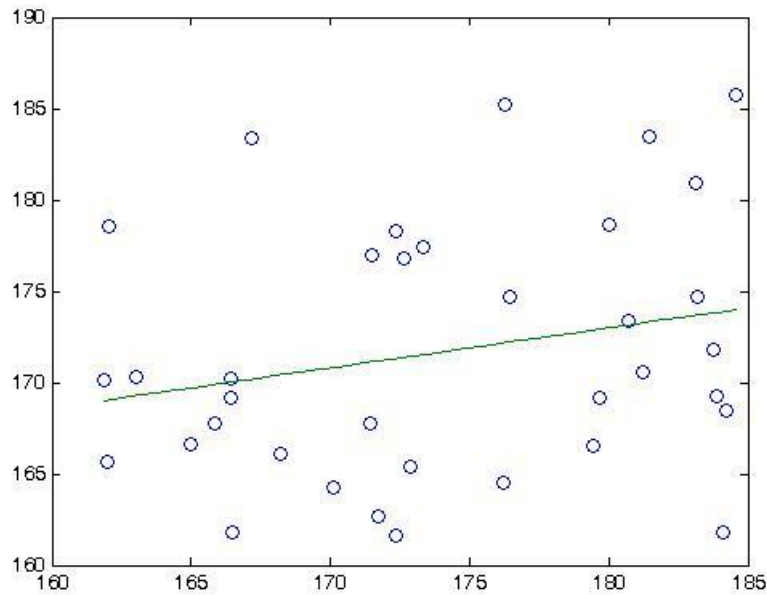
In the graphical representation in Fig. 2, there is an upward linear variation in the number of persons transported for both Carris(X2) and RATT (Y2), which contributes to the increase of the operating indicators (production, performance) with implications for the increase in the incomes achieved and which have a confidence level of 84% [2].



**Fig. 3.** The polynomial regression curve of the third degree of the rhythmicity indicator [2].

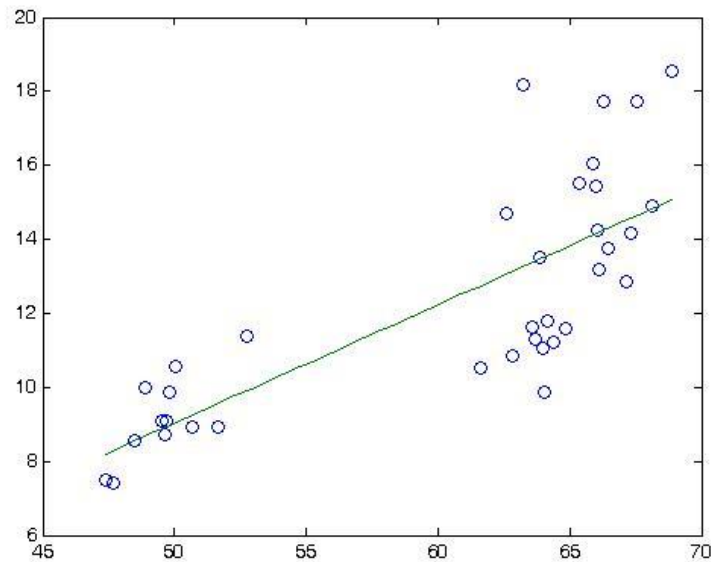
In the graphic representation in Fig. 3, it is noticed that the variation of the rhythmicity indicator cannot be assimilated with a line, the degree of confidence being decreased by 59%, which led to the adoption of a polynomial variation of the THIRD degree (quadratic) with an acceptable degree of confidence of 71%.

It is established that the rhythmicity presents sensitive variations with an upward trend in the final period of the analysis, beneficial for the improvement of the quality of the services provided.



**Fig. 4.** The right regression of the PMZ indicator [2].

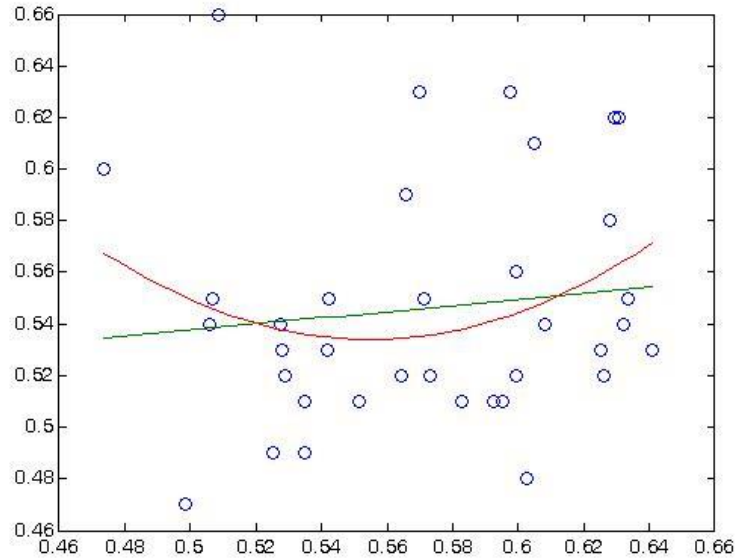
Regarding the graph in Fig. 4, it is found that the change in the indicator of the average daily PMZ course for both Carris (X4) and RATT (Y4) is a line with an upward trend, a beneficial element in improving the use of the circulating park with economic implications. The indicator variation shows a confidence level of 84%.



**Fig. 5.** The right regression of the output indicator achieved [2].

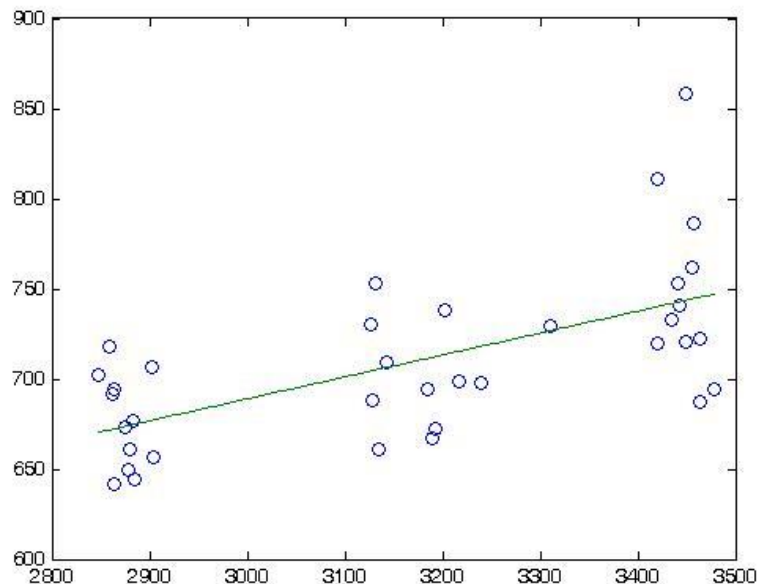
It is found that the variation of the achieved production indicator (Fig. 5) is a line with a degree of confidence that reaches the value of 86%. It is noticed that the production made in both analyzed situations is on an upward trend with an added value in the case of Carris (X5) and which contributes to the improvement of the economic activity.

In the graphic representation in figure 6, it is found that the variation of the indicator, the coefficient of use of the CUP park cannot be assimilated to a line, since the degree of confidence is less than 51%, which led to the need to adopt a polynomial variation of the parabolic type with an accepted trust level of 78%. The increase of the CUP indicator in the final period of the analysis is a beneficial element with influences in the improvement of the exploitation indicators (performance, yield, PMZ).



**Fig. 6.** Linear and parabolic regression curve of cup indicator [2].

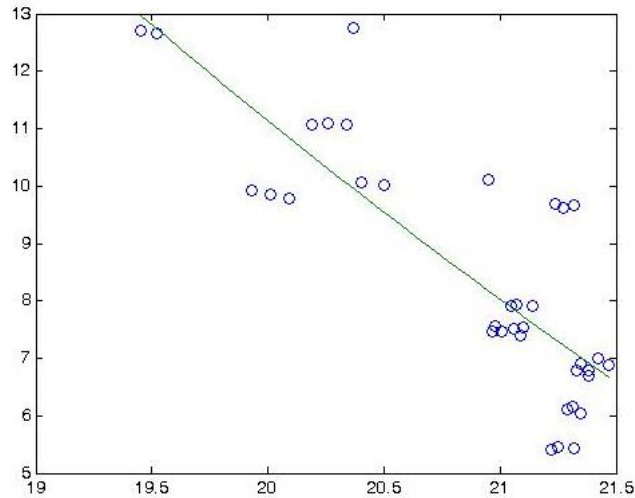
Regarding the performance indicator achieved (Fig. 7), it is found for both Carris (X7) and RATT (Y7) that the indicator presents an increasing linear variation with a level of confidence of 96%, which has a positive influence in improving the transport activity.



**Fig. 7.** The right regression of the indicator of performance achieved [2].

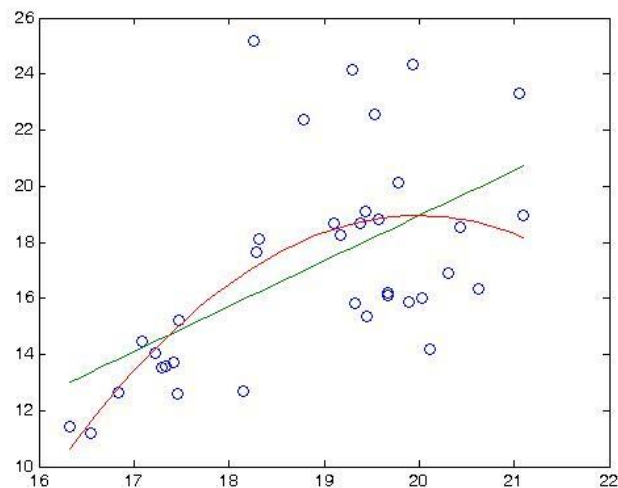
In the graphic presentation in Fig. 8, it is found that the variation of the indicator degree of loading of the means of transport cannot be assimilated with a line nor with a polynomial (quadratic)

variation, since the degree of confidence is very small 43% and 55% respectively to be accepted, which is why the variation of this indicator was assimilated with a hyperbolic variation of the opposite direction (decreasing), the degree of trust being 88%, which has a negative influence on the activity of both passenger transport companies and implicitly imposes the need to urgently take measures to improve this situation.



**Fig. 8.** Hyperbolic regression curve of the degree of load [2].

As for the graphic construction in Fig. 9 of the efficiency indicator, it can be assimilated to a parabolic variation because the confidence level is much higher than 96% with a beneficial effect on the quantitative exploitation indicators (production, performance, PMZ, CUP).



**Fig. 9.** The linear and parabolic regression curve of the yield indicator [2].

The statistical analysis of the qualitative and quantitative exploitation indicators revealed that the values of the indicators are subject to linear, quadratic and hyperbolic statistical models and which are confirmed by the verification tests in the case of the regression method, namely the  $test t_n$ .

The values of the qualitative indicators of rat Timisoara are inferior to those of Carris, if in terms of the average commercial speed these values are comparative, in terms of rhythmicity it is unacceptable in the case of RATT, the values being well above the value of  $R = 0.5$ , considered as a norm, and good in the case of Carris, the values being below this norm value.

The values of the quantitative exploitation indicators of the RATT administration are also inferior to those of Carris, if we consider the production, the performance and the transport efficiency, and in terms of the coefficient of use of the park, this is unacceptable in the case of RATT, the values being well below the CUP value = 0.85, considered a minimum accepted value, while at Carris the value of the coefficient is between the acceptable and good rating.

## CONCLUSION

Following the comparative analyses regarding the urban passenger transport directed by RAT Timișoara versus Carris Lisbon [7], the following conclusions can be highlighted:

- studies performed indicates that between Carris Lisbon and RAT Timisoara, there is a possibility that in the autonomous transport administration Timisoara we can apply the regression model;
- to analyze the statistical analysis made over the three-year period, using the regression method, established the methods of evolution of the nine indicators of the RAT Timisoara administration compared to the nine indicators from the Carris Lisbon company;
- the values of the analyzed indicators, by using the regression method, are subject to linear, quadratic, respectively hyperbolic statistical models;
- The statistical odes of the evolution of the analyzed indicators were confirmed by the verification tests specific to the regression method, namely the test  $t_n$ ;
- models are statistically supported with a confidence level of about 97%, they allow the prediction of the values of the indicators for RAT Timisoara based on the indicators of the company Carris Lisbon;
- this information can be used, in the future, to trigger the appropriate and appropriate actions, if the values of the indicators from RAT Timisoara, would depart from the wave or times given by the statistical model.

In conclusion RATT must focus on:

- increasing the quality of the services provided to the travelling public by improving the qualitative indicators of rhythmicity and punctuality;
- increasing the average commercial speed of public transport means by improving superstructure, infrastructure and prioritising public transport [5];
- ensuring at European Community level the safety and safety of passenger movements as well as the protection of the environment by upgrading the vehicle inventory fleet;
- increasing the number of passengers by improving comfort in public transport by renewing the vehicle fleet;
- improving the operating indicators, in particular, the average daily journey and the coefficient of use of the park by purchasing state-of-the-art passenger transport means [6].

## REFERENCES

- [1] Negrea, R.: Mathematics and management, Politehnica Publishing, Timisoara, 2013;.
- [2] Stefanescu, P.: Contributions to the efficiency of the public transport of people in the urban and peri-urban environment, afferent to the municipality of Timisoara, PhD Thesis, Politehnica Publishing House, Timisoara, 2014.
- [3] Ștefănescu, P., Mocan, M., Ștefănescu, W.: Inside the Ticketing System and the benefits brought by it, IEEE International Conference on System Science and Engineering Proceedings, Budapest, pp. 341-344, 2013.
- [4] Ștefănescu, P., Mocan, M., Ștefănescu, W.: Short review of factors that efficiencies the door to door public transportation system, Proceedings of the Annual Session of Scientific Papers IMT Oradea, pp. 403-406, 2013.
- [5] Ștefănescu, P., Mocan, M.: New trends in public transportation development case study Timișoara city, The International Conference on Innovation and Collaboration in Engineering Research Second Edition, București, pp. 77-80, 2013.
- [6] Ștefănescu, P.: SWOT and STEEP analysis and RATT Timișoara, Management, Knowledge and Learning international conference 2011 Celje-Slovenia, 2011
- [7] [www.carris.pt](http://www.carris.pt)



## CONSTRUCTION CLAIM MANAGEMENT

Ali Reza Afshari<sup>1</sup>, Edit Terek Stojanović<sup>2</sup>, Ali Shieh Ali<sup>3</sup>

<sup>1</sup>Department of Industrial Engineering, Shirvan Branch, Islamic Azad University, Shirvan, Iran. E-mail: [afshari@mshdiau.ac.ir](mailto:afshari@mshdiau.ac.ir)

<sup>2</sup>University of Novi Sad, Technical Faculty "Mihajlo Pupin", Zrenjanin, Serbia

<sup>3</sup>Department of Law, Shirvan Branch, Islamic Azad University, Shirvan, Iran.

**Abstract:** The significantly increasing number of construction claims indicates the need for the implementation of an effective construction claim management. This paper will look into claim problems in construction projects. The problems observed from this research could be used to solve or improve the construction claim system. The results in this study also can be used to assist contractors in adjusting to a business environment that demands measuring business processes to form a basis for continuous improvement.

**Key words:** Construction Industry, Claim Management, Construction Claim Management, Construction Management.

### INTRODUCTION

The construction sector is one of the main economic engine sectors supporting economy. The expansion of this sector has led to the revival of the construction profession, and the promotion and encouragement of new investments. The sector has played a crucial role in extending job opportunities for labor force. Its expansion has generated many jobs for skilled, semiskilled and unskilled workers. It is central as being the catalyst for development and a major indicator and determinant of domestic performance in the economy. Construction claims are considered by many project participants to be one of the most troublesome and unpleasant events of a project [1]. The high competition coupled with the sluggish global economy has forced contractors to bid projects with minimum profits to stay in business. In addition to their multiparty nature, projects are becoming more complex and risky. This has placed an added burden on contractors to construct increasingly sophisticated and risky projects with less resources and profits. Under these circumstances, it is not surprising that the number of claims within the construction industry continues to increase [2].

Construction claims appear because of problems in aspects of organization, planning, and contracts. A claim can be described as an administrative tool to correct failures that occur in the construction process. The application of good claim management will be able to avoid dispute that will have an impact on cost overrun and time overrun [3]. In the success of a project, cooperation between interested parties is needed in the course of the project; these parties are the owner, consultant, and contractor, even the supplier. However, these parties have different interests and goals so that conflicts often occur due to disagreements during project planning and development. The disagreements that occur can potentially lead to claims. The number of construction claims, and disputes is increasing and is a burden in the construction industry. Therefore, it is necessary to apply a Claim Management that is the process of coordinating resources for progress of claims from identification and analysis through identification, notification, examination, presentation, documentation, negotiation and claim settlement [4]. Sensitivity to the fundamental factors in the claim identification process plays an important role in addition to skills needed in the management of said project. Since claims cannot be properly predicted, its prevention and detection efforts require a strong claim management. Changes in terms of project documentation setting from unregulated to a regular system will have a significant impact on these prevention and control efforts. Most commonly arising construction claims are regarding time and costs as job impact changes; it is also the most difficult problems because changes do not only occur in one job, but also in the work that follows. Therefore, an effective claim management system is essential [5]. Without a system to resolve claims, a simple conflict can develop into a serious dispute affecting other aspects in other projects [6]. Claim management is a process of coordination among stakeholders for the purpose of assessing claims and resolving problems [7]. Claim management describes the processes required to eliminate or prevent more construction claims and to respond quickly when a claim occurs. Claim management process consists of identifying and analyzing sub process claim management systems through claim notification, claim recognition, claim

testing, claim documentation, claim examination, claim presentation, claim planning, claim negotiation, and claim execution [8].

## MATERIAL AND METHODS

### The Reasons for Construction Claims from contractors' point of view

The number of claims in construction projects is increasing and claims have become almost routine activities in projects. Claims can be caused by several factors and these factors can be used in the first stage of identification and prevention. According to contractors, the number one main reason for claims is Changes in owner's requirements. The second most cited reason is design changes from owner during the post-tender award stages while the third is due to project being implemented in short period with inadequate site investigation, design works, tender and contract documents and inadequate definition and specification of the precise scope of contract works. The suggestions are that owners should ensure that the project is well planned from the beginning to minimize the need for change orders or change directives because changes in the contract work can increase the risk of construction claims and decrease work productivity [3]. This section aims to identify the factors that cause the occurrence of claims during the construction work and identify the problems in each claim management process. The stages are claim identification, claim notification, claim examination, claim documentation, claim presentation and claim negotiation:

1. **Identification:** According to contractors, the main problem in identification of claim is Lack of awareness of site staff to notice a claim; insufficient contract knowledge by site staff; and insufficient skilled personnel for detecting a claim. All three problems relate to staff's skills and awareness. Staff are expected to understand contract provisions and obliged to read and assess them before the start the project.
2. **Notification:** In claim notification, the main problems arising are Inaccessibility of supporting documents needed for notice; Poor communication to proceed with submitting the notice; and Insufficient time to thoroughly prepare the notice due to high workload. The notification process must be supported by relevant documents and submitted in writing as detailed as possible. Therefore, a good documentation system and accurate site records are very important prerequisites in notice preparation procedures. In addition, site staff must have good communication skills with all stakeholders.
3. **Examination:** The next process is the examination of claims. the main problems in examination are Poor communication to gather the required information to analyze a claim and Ambiguous procedures for claim examination; Unavailability of records needed to analyze and estimate the potential recovery; and Lack of contract to establish the base on which the claim stands. Respondents indicated that communication and procedure is clearly very important to analyze claims. Contractors have to check the required files to estimate the cost by presenting documents to owners. Legal aspect/contracts can be strong reasons for the claim to stand in the examination process.
4. **Documentation:** Some information not kept in writing; Inaccurate recorded information; and Ineffective record-keeping system. This part highlights contractors' contribution to the problems in claim documentation. Project documentation must be prepared with the intention to build cases and written evidence to support arguments. If owners do not make written instructions, contractors should take the initiative to get proper written instructions from owner [3].
5. **Presentation:** Concerning presentation, the survey shows that Poor communication in presenting a claim; insufficient time to prepare claims due to high workload; and Ambiguous procedures in the preparation of claim presentation are the major problems in claim presentation. In this process, completed documents will be presented to owners and it requires good communication between participants to prepare clear. They must be aware of the claim process and know how to present the claim and defend it well. If the contractors are having difficulties in identifying and hiring experienced staff, the presentation process will be adversely affected and possibly cause the owners to reject the claim.

6. **Negotiation:** Negotiation is the main method to achieve resolution as an agreement through discussions and compromises can resolve problems before they become a dispute. Resolutions by negotiations in claim management process need a justification stage. This survey indicated that Disagreements arising during negotiation; unsatisfactory evidence to convince other parties; and Poor negotiation skills are the problems during negotiation process. Successful negotiation of claim is an important element in controlling project cost and can reduce the potential for litigation.

### Construction Projects Claim

Construction projects can be described as temporary multi-organizations, made up of a large number of different people from different backgrounds, based on different geographical locations making their contributions at a different time. These people are interdependent but unfortunately, because of their conflicting interests, are often highly insensitive to the needs of others around them. Moreover, construction is not a single, vertically or horizontally organized industry dominated by a small number of national or multinational corporations. It is a large, fragmented, decentralized industry characterized by thousands of small and medium sized companies and material suppliers. In addition to that, thousands of architects, engineers, bankers, insurance brokers, lawyers, accountants, public administrators, government inspectors, and contracting personnel play a key role [9].

Construction activity is a complex process involving many disciplines with differing skills. Therefore, problems are bound to arise in undertaking complex projects, such as a construction project, due to the widely differing values and goals among the project participants [10]. Some of these problems have the potential to escalate to become significant disputes. In addition, construction, like many other industries in a free-enterprise system, has sizeable risk built into its profit structure [11]. Although all the parties in a construction contract start with the best of intentions to get the work both complete satisfactorily in the agreed time and at the least expense to owner, whilst ensuring that the general contractor and all other specialist contractors and suppliers make a reasonable profit. Somewhere between the beginning and the end, disagreement, disputes, disruption and delay arise which can destroy the best of intentions. Therefore, the construction industry has a poor reputation for coping with risks, failing to meet deadlines and cost targets. Hence, the clients, the contractors, the public and others have suffered as a result. Construction claims have such high impact on construction project's cost and time that an effective claim management system in any construction organization deserves serious attention [5].

A claim as a right given to the party who deserves a request for compensation for damages incurred by the other party. Claim is a request by a construction contractor for compensation over and above the agreed-upon contract amount for additional work or damages supposedly resulting from events that were not included in the initial contract [12]. In any construction project, significant additional costs can be experienced by the contractor, the owner, or both, due to the actions of the other party or parties involved. Disputes over the right to a compensation as well as over the amount of time or money to be given often necessitate a resort to litigation, arbitration, or other forms of dispute resolution methods for settlement [13].

A construction claim arises when a party to a construction contract believes that in some way, by act or omission, the other party has not fulfilled its part of the bargain [11]. To put it in other words, a claim arises when one party to the contract has suffered a detriment for which that party should be compensated by the other party. Therefore, a construction claim is an assertion of and a demand for compensation by way of evidence produced and arguments advanced by a party in support of its case [7]. Many public agencies have the perception that "claims" are attempts by contractors to pursue exaggerated demands for payments, compelling the government agency to defend itself accordingly [14]. To most contractors, the term "claim" evokes a negative reaction because it signifies the necessity to participate in a frustrating process in order to gain the relief to which one is contractually and equitably entitled usually after suffering an economic loss [15]. Although public and private entities arrive at their negative view of claims from entirely different perspectives, those perceptions are intensified by an ever-increasing resentment of the consistency of the process of dispute resolution that is customarily utilized in public contract claim resolution [12].

## RESULTS AND DISCUSSION

Construction claims management is the process of employing and coordinating resources to progress a claim from identification and analysis through preparation, and presentation, before it proceeds to negotiation and settlement [7]. The key objective of the claim management process is to resolve certain problems in an effective and efficient manner. Avoiding litigation and arbitration in claim settlement is one good practice that successful contractors must keep in mind [16].

Generally, there are six stages in a claim process. It starts with identification and followed by notification, examination, documentation, presentation and negotiation of claims [2]. Construction claim identification involves timely and accurate recognition of a change. It is the first and critically important step, and it will be followed by a notification to the other party of a potential problem. Evidently, time limit requirements are also very crucial and critical. In general, the contract specifies such duties to both parties. Establishing legal and factual ground on which the claim is to be based is done during examination stage. The fourth stage is the documentation. It plays a very important role in the settlement of claims. All the supporting documents needed including drawings, specification, written instruction, cost breakdown, measurement records and many more should be compiled together. However, in reality, the importance of record management is not realized as much as it should be [17]. The entire completed document will then be submitted and presented to client for assessment. Upon receiving the official claim, client will assess and decide on the outcome. They should act fast and avoid procrastination. The final stage is negotiation. This stage concerns the process of negotiation claim to the owner, and mutual resolution of such claim [18]. If an agreement cannot be reached and both parties believe that they are in the right position, they should propose an alternative dispute resolution method. If this fails, the remaining choice is to take the matter to court.

Objectives of this research are to identify the problems associated with claim process and the areas related to claim process that can be effectively improved.

The findings highlighted the need for project staff to have more knowledge and skills in handling claims, good communication between stakeholders in project implementation, and most importantly document completion and record keeping to provide evidence when submitting the claim. Other reasons for claims are change design by owners, and projects being implemented in short time with inadequate site investigation, design works, tender and contract documents; therefore, contract strategies are essential to manage claims. From the study, it was found that the most common cause that lead to claim is a change requested by the owner, especially in the design aspect that lead to the overall project costs changes and lead to claims.

1. **Construction Project Claim Identification:** It is best to avoid construction claims from the beginning of a project and resolve claims quickly and efficiently once, they arise. Identification of any changes needs to be carried out early and distribution of the information to all stakeholders is a necessity. This will help any decision-making process by all parties. Early identification of potential claims is necessary to prevail on claim disputes arising during construction, particularly those involving additional work and compensation. Proper claim management begins with identification of a claim.

The contractor must be able to recognized and identify a claim situation goes together with notification. Most public and private contracts contain clauses requiring notification of differing site condition, changes and delay within a stated period before equitable adjustment can be pursued. It is very important to identify the source of claim. Typical sources of disputes and claims are worth noting.

A successful claim process needs people with “claims consciousness,” familiarity and awareness of potential claim situations. Although the identification of claim is automatic with the direction of change orders from the client, the contractor must be able to recognize and identify a claim situation when it first develops, not after it has become a controversy. Prompt identification and notification are very important to fulfil the contractual requirements. The contractor cannot wait too long to take actions. All rights of the contractors to claim can be lost. It may also be practical to look for assistance from expert consultants at an early stage of the claims process.

A project manager must take a proactive role in the early identification of potential claims and disputes. He is the best person to evaluate the progress of the work and identify any

developing problems on the project. Besides that, management personnel need to have a basic understanding of the terms and conditions of the contract documents. The failure to identify a claim until the end of the project may expose the contractor to contractual defenses. Therefore, project managers must be vigilant in identifying potential claims during construction.

The project staff also must have a good working knowledge of the contract documents. Familiarity with relevant technical and general terms is essential for project personnel to recognize their contract rights and duties. Communication ideas and problems is essential for efficient and effective claim management. The project staff must be knowledgeable and aware of actual conditions that differ from those expected such as soil types, interference of structures, other contractors, traffic, weather and labor are likely to be sources of changed condition. Project staffs also need to have a working familiarity with the legal concepts and right that will affect the outcome of potential claim situation.

2. **Construction Project Claim Notification:** Identification of claim must be followed by notification. It is frequent for construction contracts to require a party to give timely notice of claims to the other. Most standard form contracts provide some mechanism and contain clauses explaining the process of giving such notices and the likely consequences that will arise if notices are not given as specific in the contract. The obvious purpose of notification clauses in a contract is to ensure that both parties have on record the dates and facts that initiate a claims situation, and to protect their respective rights. Notice clauses are useful because they allow the owner of the construction project more time to react to claim problems. The procedures and reporting systems adopted by any contractors to notify claims need to be systematic. The system should ensure that all claims are notified to owner as soon as possible after the project manager become aware of any complaint or dispute, written or oral, alleging or suggesting any deficiency in the provision of the services.

On the other hand, the owner need to make it clear what the contractor has to do if it hits problems such as delay and needs to extend the completion date or claim additional money. Most of the construction contracts require written notice for changes, differing site condition, extra work or other events that may affect the contractor's time and cost performance. A notice clause should be precise, unambiguous about what is necessary, and the contractors should fulfil the conditions of the notice clause.

Prompt notification is very important to avoid the possibility of breaching contract policy conditions by late notification. Late notification is always arising from misconceived view that problem will eventually resolve itself, embarrassment of the individual or the contractor concerned, concern for the personal consequences of the individual involved and fear that the facts will be made public with the attendant risk to the contractor's reputation.

3. **Construction Project Claim Examination:** Record availability is very important in analyzing and estimating the expenses of claims. In this process, the contractors need to be aware of the need to check the required files and to estimate their claim cost by presenting accurate documents to the owner. Therefore, it is advisable for the contractors to examine claims recovery and support it by providing precise related documents. Poor communication still contributes to the problems in this stage and proper action is needed in order for it to improve. Lack of contract to establish strong reasons on which the claim stands also add to the problems in claim examination process. Knowledge and awareness in law and contract amongst the contractors need to be highlighted.

4. **Construction Project Claim Documentation:** A complete and strong claim document is important in presenting a claim, and resolve any disputes. Contractors must comply with the contract requirements such as the notice and deadlines for submitting any documentation supporting the claim. To have the strongest documentation, the information should be contemporaneously, documenting and closing out the work as it is performed. Information should be consistent and understood.

The process of preparing and presenting the claim document is very important because it requires the contractor to refine and produce the claim from beginning to end. The claim must be supported with all the required documents to explain the dispute in a simple, complete and comprehensive approach. This documentation should include the method and date of correction, with approval by the involved parties. The writing style should be clear, precise

and easy to be understood. Detail pricing the claim and supporting the damage calculations is very important. Charts, graphs, drawings, and photographs are very helpful and should be included into the claim document. Systematic photos or video of completed work, testing conducted or other quality control activities provide unquestionable visual evidence of the actual conditions.

Documents also should include specifications, special condition, specific instruction as well as the contractor's calculation and bid preparation documents are generally acceptable evidence as to what was intended by a construction contract. Make sure a project diary is kept along with diaries for key personnel and should record the weather, manpower, visitors and contractors on site, key deliveries and any notable event such as problematic or hidden site conditions or events that may cause delay or affect productivity. Well maintain an as planned schedule and regularly update it with an as-built schedule are vital. Record all key events, especially ones that may lead to a claim, and specifically record when the event occurred, what it was, who noticed it, the projected impact it may have on cost and time, whether notice was given and to whom and response to notice. Contractor should ensure that a fully signed written agreement is in place before commencing work on a project. While oral agreements are generally enforceable, written ones are easier to prove.

The contractor should regularly update the record set with the goal of capturing all changes as they are approved and with sufficient detail so that there is less remembering necessary when the final record set is compiled. Even before a claim is identified, it is important that the contractor keep good records of its activities on the project. Most documentation problems stem from, three basic conditions: Getting the proper amount and type of information, getting this information to the appropriate individual, and delivering it while it is timely.

When these considerations are addressed properly, those responsible for problem resolution will be able to respond more effectively as project challenges arise. Beyond maintaining good records of daily activities and of the project in general, the contractor must be both proactive and reactive in developing claim documentation. With respect to proactive documentation, the contractor should take immediate steps to create a record of potential claims as they arise. It is essential that the contractor respond promptly in writing to any communication concerning alleged facts or positions that may affect the viability of its claim. Where the owner, general contractor, construction manager or other relevant project participant disputes the claim or indicates that the problem has been addressed, the contractor must respond in a timely manner.

5. **Construction Project Claim Presentation:** In this process, the completed claim documents will be submitted and presented to client for assessment. If the documentation stage is not properly managed, it will affect this process and as a result, cause a failure in claim process. Presenting a claim requires a knowledgeable, skilled and experienced person to organize the full detailed claim submission. They must be aware of the claim process and know how to present the claim and defend it well. However, it is very difficult for the contractors to identify and hire experienced staff in the preparation of a claim submission. This issue affects the claim presentation process, possibly causing the client to reject the claim. Due to heavy workload, they have insufficient time to concentrate on the preparation of claim presentation. It is also very important to note the need to recruit a specialist in claim management to deal effectively with the relevant issues.
6. **Construction Project Claim Negotiation:** The purpose of negotiation is to achieve an agreement through discussion and compromise. It is very difficult to reach a satisfactory resolution of claim between project participants. Negotiation is the main approach to resolve such conflicts before they finally become disputes. In reality, negotiations go on throughout the whole claims management process from the justification stage to the settlement of a claim. Strong evidence is very much needed during this stage in order to hold up the claim and to persuade the owner. In many situations, the contractors lose their claim because of insufficient amount of documentation evidence and as a result, affecting the contractor's position during claim negotiation. In some cases, the negotiation process could jeopardize the relationship between the contractor and the owner that results from unsatisfactory claims preparation and negotiation.

The problems related with not having good negotiation skills with experienced construction workers are predictable. Many contractors do not have a committed unit or individual with the responsibility of managing the claims. Normally, the duty to manage the claim process is assigned to the project manager or site engineer, who may not possess good negotiation skills. Successful negotiation of claims is an important element for controlling project costs and reducing the potential for litigation resulting from outstanding claims.

## CONCLUSION

It was found that by having a proper claim management system; contractors can utilize it to improve their claim management process. This is to guarantee that they will have proper management setup to justify, quantify, and present claims for events under the control of the owner or his agents then chances of prolonged disputes are reduced. The results in this study also can be used to assist contractors in adjusting to a business environment that demands measuring business processes to form a basis for continuous improvement. A need for an overall systematic procedure for claims analysis and administration is very crucial for achieving proper resolutions and for preventing claims from developing into disputes.

## REFERENCES

- [1] Winch, G.M.: Managing construction projects. John Wiley & Sons, 2009.
- [2] Zaneldin, E.K.: Construction claims in United Arab Emirates: Types, causes, and frequency," International journal of project management, vol. 24, no. 5, pp. 453-459, 2006.
- [3] Hayati, K., Latief, Y., Rarasati, A.D.: Causes and problem identification in construction claim management, IOP Conference Series: Materials Science and Engineering, vol. 469, no. 1, p. 012082: IOP Publishing, 2019.
- [4] Abdul-Malak, M.A.U., El-Saadi, M.M., Abou-Zeid, M.G.: Process model for administrating construction claims, Journal of Management in Engineering, vol. 18, no. 2, pp. 84-94, 2002.
- [5] Chovichien, V., Tochaiwat, K.: Information system for managing employer's construction claims, Technology and Innovation for Sustainable Development Conference (TISD2006), 2006.
- [6] Mohamed, H.H., Ibrahim, A.H., Soliman, A.A.: Reducing construction disputes through effective claims management, American Journal of Civil Engineering Architecture, vol. 2, no. 6, pp. 186-196, 2014.
- [7] Kululanga, G., Kuotcha, W., McCaffer, R., Edum-Fotwe, F.: Construction contractors' claim process framework, Journal of Construction Engineering Management, vol. 127, no. 4, pp. 309-314, 2001.
- [8] Bakhary, N.A., Ibrahim, A., Ismail, N.A.A.: Critical review on improving the claim management process in Malaysia, Journal of Education Vocational Research, vol. 4, no. 7, pp. 214-218, 2013.
- [9] Bakhary, N.A., Adnan, H., Ibrahim, A.: Improving construction claim management in Malaysian construction industry, MATEC Web of Conferences, vol. 138, p. 05003: EDP Sciences, 2017.
- [10] Thomas-Mobley, L., Oberle, R., Kangari, R.: Design and Construction Challenges of a Federal Laboratory Building: A Case Study, Journal of architectural engineering, vol. 13, no. 4, pp. 224-229, 2007.
- [11] Tadayon, M., Jaafar, M., Nasri, E.: An assessment of risk identification in large construction projects in Iran, Journal of Construction in Developing Countries, vol. 17, 2012.
- [12] Assaf, S.A., Al-Hejji, S.: Causes of delay in large construction projects, International journal of project management, vol. 24, no. 4, pp. 349-357, 2006.
- [13] Abdul-Malak, M.A.U., El-Saadi, M.M., Abou-Zeid, M., Process model for administrating construction claims, Journal of Management in Engineering, vol. 18, no. 2, pp. 84-94, 2002.
- [14] Danuri, M.S.M.: A revisit on the current practice of dispute resolution and ADR in the Malaysian construction industry, Journal of Design Built Environment, vol. 10, no. 1, 2012.

- [15] Mohamad, M.I., Madon, Z.: Understanding contract documentation, Proceedings of the 6th Asia-Pacific Structural Engineering and Construction Conference, Asia-Pacific, 2006.
- [16] Bakhary, N. A., Adnan, H., Ibrahim, A.: A study of construction claim management problems in Malaysia, Procedia economics finance, vol. 23, pp. 63-70, 2015.
- [17] Ho, S. P., Liu, L.Y.: Analytical model for analyzing construction claims and opportunistic bidding, Journal of construction engineering management, vol. 130, no. 1, pp. 94-104, 2004.
- [18] Ren, Z., Anumba, C., Ugwu, O.: Multiagent system for construction claims negotiation, Journal of Computing in Civil Engineering, vol. 17, no. 3, pp. 180-188, 2003.



## SOCIAL RESPONSIBILITY AND SUSTAINABLE DEVELOPMENT

Radmila Čokorilo<sup>1</sup>, Cariša Bešić<sup>2</sup>, Snežana Bešić<sup>3</sup>

<sup>1</sup>Independent University of Banja Luka, Faculty of Political Science, Banja Luka 78000, BiH  
e-mail: [vrbasvrbas@gmail.com](mailto:vrbasvrbas@gmail.com)

<sup>2</sup>University of Kragujevac, Faculty of Technical Science in Čačak,  
Svetog Save 65, Čačak 32000, Republic of Serbia  
e-mail: [carisa.besic@sbb.rs](mailto:carisa.besic@sbb.rs)

<sup>3</sup>Academy of Technical and Art Applied Studies Belgrade, Departments School of Railroad  
Transport, Zdravka Čelara 14, Beograd 11000, Republic of Serbia  
e-mail: [snezana.besic63@gmail.com](mailto:snezana.besic63@gmail.com)

**Abstract:** Global market and the conditions of modern business require companies to make changes in their business philosophy, as well as ways to implement their business practices. Modern business philosophy implies that organizations must be responsible for their actions and acts towards all actors in the environment. In order to achieve the goals of business excellence, an organization must actively implement the principles of social responsibility. Social responsibility is one of the most significant management principles in modern business, which is oriented towards the future and the development of a sustainable economy.

**Key words:** social responsibility, quality, competitiveness, sustainable development.

### INTRODUCTION

Changes in the modern world, the technological development in particular, indicate the need to reassess the way of thinking about business. Competitiveness in the global market is getting stronger every day, and competitive relations have changed. Technology will be the most dynamic factor of economic development in the future as well, whereas turbulences will be more frequent and stronger.

Accumulated problems in the social environment, arising as the consequence of industrial society, have created the need for more discussions about corporate responsibility both at national and global level. Ecological rationality has become an integral part of economic practice of the most developed countries in the world. Conservation of natural resources, especially the rational use of all resources and their potentials became of strategic importance, from the aspect of development priorities. The information revolution is our reality, however, the global economy is still taking shape. Sustainability has become a global development imperative.

The global market results in global competition, which is becoming more intense and offensive. Companies compete at the level of technical and organizational innovations, not only within one industry, but between industries as well. Global competition is shifting from price and technical innovations levels to the area of knowledge management and innovations in the field of management and marketing. At the global level, guidelines of sustainable development are defined, which should create the balance between the goals of economic development on the one hand, and social development on the other, complying with the need to improve and protect the environment.

All of this influences business entities to better dedicate themselves to meeting the goals of a larger number of interest groups in their environment.

According to the World Economic Forum [7, pg. ix], it has become clear that the issues of environment and social and economic development must be considered together, in terms of forming a single agenda for action. Technological achievements materialized in Industry 4.0, create exceptional opportunities and challenges. The results of the 4th industrial revolution are already visible, and business organizations and countries have started to apply new technological advances in order to achieve competitiveness on the global market.

Nowadays business organizations have become aware of the fact that they influence society as well. This cognition has far-reaching consequences. The implementation of corporate ethics principles has the global character, too. Public interest is an organization's primary interest, which has to be incorporated in the business policy of an organization, and the business policy of an organization must be fully implemented in business.

According to Kotler and oth. [3, pg. 633], sustainability, which implies the ability to meet the needs of humanity, without harming future generations, is nowadays the priority of many companies. Raising the level of social responsibility in business requires acting in three directions which imply legal, ethical and socially responsible behavior.

In modern society knowledge becomes a strategic source of power and wealth, with the users of knowledge being the basic social group, namely, these are the persons who are able to put knowledge in the function of conducting business activities. Education and knowledge are new factors of competitiveness. This means that every employee in an organization should take responsibility for the given achievements of the organization and for its contribution and behavior. All members of an organization must fully recognize and consider their own achievements and contributions.

## **1. CORPORATE SOCIAL RESPONSIBILITY**

Modern business philosophy implies that a company must be responsible for its actions and acts towards all actors in the environment – both in macro environment and in the company itself. In this respect, a company is obliged to meet all requirements of consumers, society, partners, workers and shareholders. From this point of view, the entire system lies on the individual, who must become “a responsible individual“ whose work and actions contribute to increasing productivity, and thus to general well-being. It is considered that modern perception of responsibility implies corporate responsibility in economic, environmental and social domains [5, pg. 28].

Previously it used to be enough for a company to meet its basic economic goals – profit, being the basis for achieving goals of growth and development. Since the 1970s, improving the environment and meeting consumer demands have become increasingly important business goals. The nineties brought with them the necessity of satisfying general social interests.

The emergence of the term Corporate Social Responsibility (CSR) dates back to the 1970s, and from then until today various forms have appeared. We should also not ignore the fact that the forms of corporate social responsibility have been influenced by technological and social changes in the world, which have contributed to a change in awareness of what this concept represents. Initially, companies' focus was on philanthropic activities, and in the following period it was on work practice and ethical business. Current trends in the field of implementation of a good business practice refer to the issues related to: human rights, environmental protection, consumer protection, fight against corruption, support to social problems etc. [1. pg. 14].

Strengthening of the Japan's economic influence also resulted in greater interest in the Japanese management, especially during the 1980s. This model, designated by Western experts as the Total Quality Management (TQM) has in a very short time become the predominant model of improving the quality of business on an international scale. This model incorporated requirements for social responsibility. According to this management model, business organizations must be responsible for environmental protection, consumer protection, protection of employees' interests, for improving the productivity and knowledge of all employees.

Achieving business excellence goals of an organization pre-supposes a structured corporate social responsibility. It represents a commitment to improving the well-being of the community through discretionary business practices and contributions at the expense of company resources. [4, pg. 3]. The key word of this definition is discretionary. It means a voluntary orientation of an organization and its decision to select and apply contributing business practices. Some of the reasons for implementation and development of corporate social responsibility are as follows: increase in market share, strengthening the brand position, strengthening the corporate image, improving the ability to attract and motivate the employees, reducing business costs, increasing the attractiveness for investors. According to some viewpoints, we can currently distinguish six social initiatives that operate in the domain of corporate social responsibility: promoting social goals, marketing related to social goals, corporate social marketing, corporate philanthropy, volunteer work for the community, socially responsible business practice.

Nowadays the concept of corporate social responsibility has been standardized and represents the component of integrated management systems. Instead of a long lasting creation of the TQM concept, the business excellence goals can be achieved in a shorter time period, by applying one by one module of integrated management systems, based on meeting the conditions of international standards ISO

9001, ISO 14001, ISO 18001 and ISO 26000. The International Standardization Organization published ISO 26000 by providing the guidelines for social responsibility (SR). The ISO 26000 standard is directed to all types of enterprises, in public and in private sector, in developed countries and in developing countries. ISO 26000 represents the added value to the existing initiative for social responsibility, by providing harmonization, appropriate global guidelines based on the international consensus of the main representatives of the stakeholder expert groups and thereby encouraging implementation of the best social responsibility practice all over the world.

The quality management concept incorporates the need for environmental protection. And not only for the environmental protection, but for improving the health of people as employees and as consumers. The final goal of implementation of the TQM concept is to achieve the Total Quality of Life (TQL). These goals are directly based on the concept of sustainable development. On the other hand, the integration of management standards creates the preconditions for achieving the goals of business excellence and sustainable development.

Some of the reasons for implementation and development of corporate social responsibility are as follows: Some of the reasons for implementation and development of corporate social responsibility are as follows: increase in market share, strengthening the brand position, strengthening the corporate image, improving the ability to attract and motivate the employees, reducing business costs, increasing the attractiveness for investors.

Kotler and oth. [3, pg. 22] believe that, since the effects of marketing are felt outside the company, beyond consumers, and reflected on the society as a whole, marketing experts must consider the ethical, legal and social context, as well as the context in relation to the environmental, their roles and actions.

## **2. CORPORATE SOCIAL RESPONSIBILITY IMPLEMENTATION IN TRANSITION COUNTRIES**

The implementation of the concept of social responsibility is of special significance for the enterprises originating from transition countries, due to the fact that in this way their competitive position on the market is improved. Namely, the socially responsible business practice requires combination of various management methods and techniques, such as integrated management systems, relationship marketing, benchmarking etc., which ultimately means that, by applying modern methods and techniques of management, a company improves its business practice, and thus improves its competitiveness.

Critical thinking and business problems solving, creativity and adequate human resource management are certainly essential elements of management which will be significant in the future as well [2]. The analysis of viewpoints of top corporate managers [6] operating in the global market, indicates, among other, the need for the following guidelines:

- *understanding how we operate and what we value,*
- *understanding the technology,*
- *creating the local sustainability system,*
- *improving our relation with the nature,*
- *shortening the innovation cycle,*
- *fight against misinformation,*
- *business leaders should be more interested in science,*
- *better support to innovations and creativity.*

For most companies in transition countries it is characteristic that they have the opposite performance than those expected for a successful corporation in the future – they are not flexible, there is no critical and creative thinking, there is no leadership behavior, there is no good human resource management. This condition must be changed, because the global market knows no boundaries – global competitors from all over the world come to national and regional markets and compete with domestic companies. For this reason domestic companies must work on improving the quality of business, as the most important precondition for strengthening competitiveness, but they also have to work on establishing local sustainability.

Institutions are one of the most important factors that indicate the condition and opportunities for

---

establishing sustainability at the level of the national economy. The report of the World Economic Forum on global competitiveness, being the first pillar of competitiveness, analyses institutions. There are several sub-criteria within this pillar, whereas the criterion of government orientation towards the future directly refers to the issue of condition and possibilities of improving the environment.

Within this criterion, being the integral part of the competitiveness pillar of *institutions*, the following significant determining factors can be identified: long-term vision, legislation related to energy efficiency, legislation related to renewable energy sources and legislation that addresses the issues of environmental hazards.

**Table 1:** Comparative presentation of institutional influences and possible environmental hazards in 2019, the Western Balkans region, [7]

Country	Position as regards global competitiveness	Long-term vision	Environmental hazards
Bosnia and Herzegovina	<b>92</b>	<b>138</b>	<b>132</b>
Montenegro	<b>73</b>	<b>79</b>	<b>79</b>
Croatia	<b>63</b>	<b>137</b>	<b>17</b>
North Macedonia	<b>82</b>	<b>119</b>	<b>126</b>
Slovenia	<b>35</b>	<b>97</b>	<b>11</b>
Serbia	<b>72</b>	<b>80</b>	<b>79</b>

Source: The Global Competitiveness Report 2019, World Economic Forum, October 2019, pages 102, 174, 398, 434, 498, 514. [www.weforum.org](http://www.weforum.org)

As shown in the table, all the above indicated countries are ranked worse when it comes to the existence of an exact long-term vision by the state administration, compared with the aggregate index of global competitiveness. Long-term vision, defined by the state and its institutions, is essential for achieving the issue of sustainability of a national economy.

### 3. CONCLUSION

Corporate social responsibility is one of the pillars of business excellence of an organization. Companies from countries in transition are already required to apply the principles of environmental protection, consumer protection, protection of employees' rights etc. In the future it will be necessary to achieve sustainable productive economic growth which is the key to improving the lives of individuals. Governments of national economies should create such conditions for the workforce to engage in the process of improving business productivity by using the effects of the fourth technological revolution and Industry 4.0. Application of the corporate social responsibility concept in domestic companies should provide formation of conditions for a more successful market presence. This also means application of integrated management systems, which directly influence the improvement of business productivity of a modern organization. Knowledge, and especially the application of modern management methods and techniques, must be the basic initiator of these activities.

### REFERENCES

- [1] Bogetić, S., Đorđević, D., Čočkalović, D., Vorkapić, M.: Corporate social responsibility as a factor of global competitiveness, Journal of Engineering Management and Competitiveness (JEMC), TF Mihajlo Pupin, Zrenjanin, Vol 8, No 1, pp. 11-19, 2018.
- [2] Futures of Jobs Report 2020, World Economic Forum, 20 October 2020, [www.wef.org](http://www.wef.org)
- [3] Kotler P., Keller K.L., Martinović M.: Marketing management (In Croatian: Upravljanje marketingom), Mate, Zagreb, 2014,
- [4] Kotler F., Li N.: Corporate social responsibility (In Serbian: Korporativna društvena odgovornost), Čigoja, Belgrade, 2007,

- [5] Bartol, L.: The age of responsibility (In Croatian: **Doba odgovornosti**), Mate, Zagreb, 2010,
- [6] Parker G.: 20 views on the biggest opportunity for change after pandemic, World Economic Forum, 13 November 2020.
- [7] The Global Competitiveness Report 2019, World Economic Forum, [www.weforum.org](http://www.weforum.org).

## CONSTRUCTION SAFETY MANAGEMENT

Ali Reza Afshari<sup>1</sup>, Dragica Radosav<sup>2</sup>, Elaheh Tavakolian<sup>3</sup>

<sup>1</sup>Department of Industrial Engineering, Shirvan Branch, Islamic Azad University, Shirvan, Iran. E-mail: [afshari@mshdiau.ac.ir](mailto:afshari@mshdiau.ac.ir)

<sup>2</sup>University of Novi Sad, Technical Faculty "Mihajlo Pupin", Zrenjanin, Serbia

<sup>3</sup>Department of Construction Management, Shirvan Branch, Islamic Azad University, Shirvan, Iran.

**Abstract:** Construction industry is considered as the most hazardous industry due to its unique nature. Safety management is essential to control hazards and improve success in project implementation. A large number of construction safety studies with the variety of topics make it difficult for stakeholders to have an overview of this field. The purpose of this study is to examine safety management in the construction industry. This paper focuses on evaluating the crucial factors influencing safety management in construction projects. Finally, this review identified and discussed research gaps and corresponding agenda that can serve as guidance for future construction safety research.

**Key words:** Construction Industry, Safety Management, Construction Safety Management, Construction Management.

### INTRODUCTION

The significance of the construction industry to the economic and social life of the country is noteworthy. The industry needs much investment and involves various types of stakeholders and participants. From the point of view of safety the conditions normally encountered in the construction industry does not lend themselves to the degree of control, Possible in other industries where more stable conditions are generally obtained. The construction industry is usually very large, complex, and different from other industries. Hence, it is prone to numerous health hazards. Construction projects have recorded several work related accidents and injuries. Construction industry is considered as the most hazardous industry due to its unique nature. Globally, construction employees have three times more chances of dying and two times of being injured than any worker of other economic activity [1]. The majority of construction injury cases are simply related to poor decision making, which can be prevented through adequate safety culture. Construction accidents may occur on a project site due to collapse of construction parts or elements, unsafe working areas, human behavior and misuse of machineries [2]. The adoption of health and safety culture is without doubt an essential element required in the construction process to influence project environment to realize its profitability or stipulated outcomes [3].

Safety management involves the use of appropriate procedures towards the eliminating or reducing of accident occurrences, injuries, and damage to plants, equipment and adjoining properties. For many years safety professional have been aware that the majority of workplace accidents are triggered by unsafe behaviors, and that their control is one of the keys to successful accident prevention. However, many organizations, even those companies with low accident rate have been frustrated by their inability to control unsafe acts. The construction industry has traditionally been considered as a hazardous occupation due to the high incidence of occupational injuries and fatal accidents. The number of fatal occupational accidents in construction all users the world is not easy to quantify, as information on this issue is not available for most countries. The construction industry has some special features that have a direct bearing on the accident potential. In this trade, the pattern of work is ever changing. The operations and physical circumstances change constantly unlike in the factories where the process, the method and the operations are generally respective. Timings and schedules vary considerably from place to place. The most important changing factor the change of men themselves. The inherent nature of construction jobs combined with the above factors make this industry as one with accident risks [4].

Many articles with a variety of topics on construction safety have been published. These research results can serve as the foundation of progressing construction safety management. For example, Laukkanen [5] conducted a review of occupational health and safety training in the construction

sector. Pinto et al. [6] was concerned with traditional management methods related with occupational health and safety areas, and pointed out the major limitations of these methods to deal with construction safety issues. Another literature review was conducted by Zhou [7] to explore relationships between construction safety and digital design practices with the purpose of fostering and directing further study. Swuste et al. [8] implemented a critical review focusing on the question of whether or not it is possible to influence safety in the building sector. Zhou et al. [9] reviewed previous studies in the area of innovative technology applications for construction safety management. This study is especially vital to new researchers in aiding them to obtain a wider perspective of construction safety management. It can also support in-depth investigation and offer potential chances for researchers and practitioners to fill the gaps between research and practice in the field of construction safety.

## **MATERIAL AND METHODS**

### **The Nature of Construction**

The primary barrier to successful management system implementation seems to be the nature of the construction process itself. A common response to the cause of the decrease of safety in construction is the 'nature' of the work environment. The 'nature' of construction is a cooperative effort of several participants, each with their own perspectives and interests at hand, brought together to complete a project plan that typically changes several times while being constructed, while trying to minimize the effects of weather, environment, occupation hazards, schedule delays, and building defects. The overall construction process, in itself, can potentially lead to errors or inefficiencies. The construction industry has traditionally consisted of three primary participants: the owner or customer, the designer or engineer, and the contractor. The basic construction process occurs like this: the owner hires an architect or engineering firm to design the project and places the project out for bid to contractors, and the contractors perform the actual construction work. Even though a common project goal is shared, participants retain their own interests or what they hope to gain from the construction process. The typical owner would probably agree that they would like to spend as little as possible to get their desired project completed. Designers are in business to provide a service to the owners; however, their relationship with the contractors is often unclear. The contractors attempt to provide the product as drawn by the designer as efficiently as possible in order to maximize their profit. These somewhat conflicting and sometimes competing interests are just one element of the nature of construction, and can lead to many of the issues discussed below [10].

The contractor group can range from general contractor (construction management) to subcontractor. Moreover, is sometimes characterized by industry such as industrial, residential, highway, service and maintenance. Material and equipment companies most often referred to as suppliers also fall under this group, although their role may only be delivery to a project site. Contractors vary greatly in size. A construction firm can also be distinguished by whether it has a union, non-union, or mixed workforce. The typical construction bidding process starts with the release of a project description for public review by contractors. The details of the project can vary, but typically specify enough detail so that experienced contractors can create an accurate bid for the job. Some contract bidding is open only to general contractors, who are required to do the hiring of subcontractors after they are awarded the contract. There is concern among contractors and researchers alike, over competitive bidding for construction projects. For example, a contractor may try to reduce allotted resources towards safety or quality management in order to maintain a healthy profit margin for the job. They may also experience schedule delays for many reasons: weather, labor shortage, late delivery of equipment or materials, and other events beyond the control of the contractor [10].

In summary, the nature of the construction clearly presents a barrier for successful safety efforts. It begins with how well the designers solicit the expectations of the owners and integrate those needs into the project design. Designers also have the opportunity to minimize the creation of worksite hazards through safety planning [11]. The competitive bidding process provides an opportunity for contractors to cut safety budget items in order to win the job. The contract itself is a symbol of accountability, as it designates who is at most risk during the construction phase. The hiring of subcontractors and suppliers can also be tricky, if the general contractor had no prior work relationship

with them. Finally, unpredictable elements such as weather or hidden ground or constructed problems can hinder a time schedule and increase construction costs. It would appear that a great deal of coordination, knowledge, and pre-planning is needed in order to complete a construction project on schedule and within the allotted budget. This is why the authors believe a safety management system could be an innovative way to improve the safety performance in construction work.

### **Construction Safety Research**

Early concepts of safety management were developed by Heinrich [12] in the 1930s, and espoused in his book 'Industrial Accident Prevention'. Heinrich realized that industrial accidents were more likely to be caused by unsafe acts by people than caused by physical hazards. This concept ushered in an innovative management system approach, which addressed both physical hazards and the behavior of workers. Petersen [13] elaborated on Heinrich's work, and published a text of safety management concepts that address the human element of occupational safety. Research has shown a strong correlation between successful safety programs and management commitment in the safety program; more humanistic approach in dealing with employees; better employee selection procedures; more frequent use of lead workers performing training; greater degree of housekeeping; better plant environmental qualities; and a stable workforce. Goh and Chua [14] (2013) used neural network to study relationship between safety management elements and accident severity. In addition, there was an increasing focus on proactive management of accidents, for example safety plan, safety training, safety monitoring, near miss management, and safety knowledge.

### **Safety planning**

Saurin et al. [15, 16] (2004, 2005) integrated safety planning and control (SPC) into the construction planning and control process at three hierarchical levels of short, medium and long term. Yi and Langford [17] (2006) proposed a theory of safety planning method which could estimate the risk distribution of a project and help managers evaluate situations of safety risk. Goh and Chua [18, 19] (2009, 2010) proposed a case-based reasoning approach to construction safety risk assessment, aiming to utilize past risk assessment and incident cases to improve the efficiency and quality of new hazard identification. Geographic information system (GIS) was applied in construction safety planning by Bansal [20] (2011) in a real project in India.

### **Innovative technologies**

Diverse innovative technologies were adopted to improve safety training in construction. One application was the computer-based safety training (CBT) of Hispanic construction workers by Evia [21] (2011). Virtual reality technology was used to develop a game technology based safety-training platform to promote the safety of construction plant operations by Guo et al. [22] (2012). Teizer et al. [23] (2013) proposed a novel approach towards integrating real-time location tracing and 3D immersive data visualization technologies to improve ironworkers' education and training in safety and productivity.

Another area of research was the use of technologies to facilitate collection and monitoring of real-time safety information. These technologies include differential global positioning system (DGPS) [24] (Oloufa et al., 2003), sparse point cloud [25] (Kim et al., 2005), sensor [26] (Lee et al., 2009), remote sensing [27] (Teizer et al., 2010) and radio frequency identification (RFID) [28] (Yang et al., 2012).

### **Safety knowledge management**

Effective knowledge management has been indicated by the academia to significantly further organizational performance and improve long-term competitiveness [29-31] (Alavi and Leidner, 2001; Ruikar et al., 2007; Hallowell, 2012). Safety knowledge management was also identified as an important area of construction safety. For instance, Hadikusumo and Rowlinson [32] (2004) conducted a study on a design-for-safety-process tool to capture construction safety hazards and the safety



measures required from safety engineers. To investigate how safety knowledge management strategies, were employed in the construction industry, Hallowell [31] (2012) conducted 11 case studies on a geographically dispersed sample of general contractors in the United States. Ding et al. [33] (2012) developed a knowledge base using construction drawings, to facilitate risk identification in subway projects.

## **RESULTS AND DISCUSSION**

Overall, the studies reviewed support the basic characteristics of successful safety management programs. Management commitment and communication were the most frequently studied safety program characteristics and tended to be related to successful construction safety programs. The use of audits and observations, measures of safety culture or climate, and employee involvement were also frequently studied and found to contribute to improved construction safety performance. With regard to safety culture and climate, when the workforce perceived safety as important and felt empowered or committed to the project, they kept the site clean and orderly [34]. Worksite accident investigation was found to improve safety, but it was disguised as drug testing after an accident [35]. The most commonly used measure for safety performance was the subjective responses collected during surveys and interviews. However, some studies confirmed that the use of survey responses from management and workers are representative of reported incidence rates or other rates associated with injuries or accidents. This provides support for the notion that workforce safety perception seems to influence safety behavior. Several studies alluded to quality management either as a means to address safety or as an outcome measure. Glazner et al. [36] found that contractors who reported lower no lost work time injury rates also tended to complete their contract on budget rather than over-budget. The quality management characteristic of continuous improvement was found to improve safety performance through increased communication and feedback from management to workers, resulting in a higher level of safety commitment by both parties [35, 37, 38]. Interestingly, Ketola et al. [37] reported that construction companies that used previous process improvement or quality management initiatives had a much easier time evaluating and improving their safety program. There is a wide acceptance that a clear, comprehensive, and practicable safety plan should be formulated to ensure safety performance [15, 39].

### **Research findings**

Despite the diversification of research topics in the field of construction safety, they are mainly derived from two research perspectives: management-driven and technology-driven. As to the first perspective, corresponding researchers deem that enhancing management performance can effectively guarantee construction safety and avoid fatalities or injuries on construction sites. The studies from the perspective of management usually involve safety climate, safety culture, worker's competency or behavior, hazard management, and so on. The other perspective focuses on how to use different types of technologies to ensure construction site safety. Because to err is human and an ideal safety management system without any human errors cannot be provided, various innovative technologies can serve as the last barrier to timely identify human errors and deal with them, and finally prevent construction accidents. Technology-driven safety can assist management-driven safety, rather than replace. Both of them are mutually dependent and cooperative.

Construction safety research are varying with the times. At the beginning, the academia was mainly concentrated on construction accident data, inclusive of conducting accident statistics, analyzing causing factors, calculating accident cost and so on. Given that site workers are the direct stakeholders' involvement in construction fatalities/injuries, researchers turned the focus to individual characteristics of site workers, e.g. behavior, perception, attitude, competency and psychology. Comparing with individual characteristics of site workers, group/organizational characteristics are more fundamental and they can have heavy impact on individual characteristics of workers. The academia subsequently tried to explore the impact of group/organizational characteristics on construction safety, in a range from the relationship among workers to organizational safety climate or culture. The trend of construction safety research is much more diversified at present.

Construction projects are often built in an unstructured and changing environment due to their inherent complexities and difficulties. Therefore, safety hazards or risks in construction sites cannot be completely excluded. Innovative technology application can be an intermediate solution to prevent workers from injuring in an environment with safety risks.

The way of safety management in the construction industry has varied from reactive to proactive. Safety information flow plays a key role in this variation. Proactive safety management requires safety information flow to be more smooth and efficient. Construction safety management is a process of safety information flow involving information collection, transmission, storage, analysis, estimation, visualization and response. Various innovative technologies can be adopted to assist in managing safety information flow. Radio frequency identification (RFID), laser scanning, sensor, and global positioning system (GPS) were used to collect safety related information, such as identity information, location information, and environment information. Wireless network and ultra wideband were used to transmit safety information to the right places and persons. Analytical technologies and visualization technologies were combined to analyze safety information and visualize the results of safety assessment, in order to guide construction practice to the avoidance of fatalities or injuries.

### **Recommendations for Future Research**

Numerous studies have examined the construction industry's performance and most concluded that its fragmented nature, lack of coordination and communication between parties, adversarial contractual relationships, and lack of customer focus inhibit the industry's performance. Based on the availability of research pertaining to safety management in manufacturing, construction has been given very little attention by the academic community. The next step for academic researchers is to take a more holistic approach to studies in the construction industry. Involving owners, designers, general contractors, suppliers, and subcontractors in data collection would enrich the data and provide more insight to analysis. One common error noted in available studies is that most performance indicators are latent representations, or lagging indicators, of safety. Finally, as noted by the response rates of the studies cited as well as our own personal experience, the 'nature' of construction also makes it difficult to perform research [40]. Perhaps, through continued support by trade unions, professional construction organizations, and entities, the academic community can continue to make progress to assist the construction industry in its quest to improve safety performance.

The academia has already done a significant number of studies related to construction safety, and these studies have demonstrated many benefits for the construction industry. The diversification of construction safety topics shows that researchers and practitioners are exploring a variety of paths to advance construction safety management level. Nevertheless, this review still identified six research gaps that will be discussed below. Corresponding research agenda are also proposed: Lack of unsafe behavior monitoring, Lack in applying safety climate to accident prediction, Ignorance of quantitative relationship identification between, Lacks of construction safety research at the task level, Excessive concentration on building project and construction phase, Lack of innovative technology applications in construction safety practice.

### **CONCLUSION**

The nature of construction is a very real barrier to safety management success. However, as several researchers indicated, the construction industry is too different and complex simply to take a successful management system from manufacturing and transplant it into construction. It may take an effort by academia to educate the construction industry to realize that a policy-level change is needed before construction safety can improve. The work environments in construction activities are generally more hazardous, than other industries due to the use of heavy equipment, dangerous tools, and hazardous materials, all of which increase the potential for serious accidents and injuries. Therefore, it is evident that a focused dedication inwards safety is needed from construction at all levels. It can be inferred from the survey data that safety managers have the opportunity to influence and enhance the sense of safety and the quality of the work environment. Owners of large projects can more actively participate in construction safety management in each stage of project execution.

## REFERENCES

- [1] S. Sousa and J. Teixeira, "Prevention measures to reduce risk of falling from heights," in *IX National Symposium of ISMAI*, 2004, vol. 14, p. 15.
- [2] T. S. Abdelhamid and J. G. Everett, "Identifying root causes of construction accidents," *Journal of construction engineering management*, vol. 126, no. 1, pp. 52-60, 2000.
- [3] H. N. Husin, H. Adnan, and K. Jusoff, "Management of safety for quality construction," *Journal of Sustainable Development*, vol. 1, no. 3, pp. 41-47, 2008.
- [4] T. Subramani and R. Lordsonmillar, "Safety management analysis in construction industry," *International Journal of Engineering Research Applications*, vol. 4, no. 6, pp. 117-120, 2014.
- [5] T. Laukkanen, "Construction work and education: occupational health and safety reviewed," *Construction Management Economics*, vol. 17, no. 1, pp. 53-62, 1999.
- [6] A. Pinto, I. L. Nunes, and R. A. Ribeiro, "Occupational risk assessment in construction industry – Overview and reflection," *Safety Science*, vol. 49, no. 5, pp. 616-624, 2011/06/01/ 2011.
- [7] W. Zhou, J. Whyte, and R. Sacks, "Construction safety and digital design: A review," *Automation in Construction*, vol. 22, pp. 102-111, 2012/03/01/ 2012.
- [8] P. Swuste, A. Frijters, and F. Guldenmund, "Is it possible to influence safety in the building sector?: A literature review extending from 1980 until the present," *Safety Science*, vol. 50, no. 5, pp. 1333-1343, 2012/06/01/ 2012.
- [9] Z. Zhou, J. Irizarry, and Q. Li, "Applying advanced technology to improve safety management in the construction industry: a literature review," *Construction Management and Economics*, vol. 31, no. 6, pp. 606-622, 2013/06/01 2013.
- [10] T. W. Loushine, P. L. Hoonakker, P. Carayon, M. J. J. T. Q. M. Smith, and B. Excellence, "Quality and safety management in construction," *Total Quality Management Business Excellence*, vol. 17, no. 9, pp. 1171-1212, 2006.
- [11] S. Hecker and J. A. Gambatese, "Safety in design: a proactive approach to construction worker safety and health," *Applied Occupational Environmental Hygiene*, vol. 18, no. 5, pp. 339-342, 2003.
- [12] H. W. J. I. A. P. A. S. A. Heinrich, "Industrial Accident Prevention. A Scientific Approach," no. Second Edition, 1941.
- [13] D. Petersen, *Safety Management: A Human Approach*. Aloray. Inc., New York, 1988.
- [14] Y. M. Goh and D. Chua, "Neural network analysis of construction safety management systems: a case study in Singapore," *Construction Management and Economics*, vol. 31, no. 5, pp. 460-470, 2013/05/01 2013.
- [15] T. A. Saurin, C. T. Formoso, F. B. J. E. Cambraia, Construction, and A. Management, "Analysis of a safety planning and control model from the human error perspective," 2005.
- [16] T. A. Saurin, C. T. Formoso, L. B. J. C. M. Guimarães, and Economics, "Safety and production: an integrated planning and control model," vol. 22, no. 2, pp. 159-169, 2004.
- [17] K.-J. Yi, D. J. J. o. c. e. Langford, and management, "Scheduling-based risk estimation and safety planning for construction projects," vol. 132, no. 6, pp. 626-635, 2006.
- [18] Y. M. Goh, D. J. J. o. C. E. Chua, and Management, "Case-based reasoning for construction hazard identification: Case representation and retrieval," vol. 135, no. 11, pp. 1181-1189, 2009.
- [19] Y. M. Goh, D. J. J. o. C. E. Chua, and Management, "Case-based reasoning approach to construction safety hazard identification: Adaptation and utilization," vol. 136, no. 2, pp. 170-178, 2010.
- [20] V. K. Bansal, "Application of geographic information systems in construction safety planning," *International Journal of Project Management*, vol. 29, no. 1, pp. 66-77, 2011/01/01/ 2011.
- [21] C. Evia, "Localizing and designing computer-based safety training solutions for Hispanic construction workers," *Journal of Construction Engineering Management*, vol. 137, no. 6, pp. 452-459, 2011.

- [22]H. Guo, H. Li, G. Chan, and M. Skitmore, "Using game technologies to improve the safety of construction plant operations," *Accident Analysis & Prevention*, vol. 48, pp. 204-213, 2012/09/01/ 2012.
- [23]J. Teizer, T. Cheng, and Y. Fang, "Location tracking and data visualization technology to advance construction ironworkers' education and training in safety and productivity," *Automation in Construction*, vol. 35, pp. 53-68, 2013/11/01/ 2013.
- [24]A. A. Oloufa, M. Ikeda, and H. Oda, "Situational awareness of construction equipment using GPS, wireless and web technologies," *Automation in Construction*, vol. 12, no. 6, pp. 737-748, 2003/11/01/ 2003.
- [25]C. Kim, C. T. Haas, and K. A. Liapi, "Rapid, on-site spatial information acquisition and its use for infrastructure operation and maintenance," *Automation in Construction*, vol. 14, no. 5, pp. 666-684, 2005/10/01/ 2005.
- [26]U.-K. Lee, J.-H. Kim, H. Cho, and K.-I. Kang, "Development of a mobile safety monitoring system for construction sites," *Automation in Construction*, vol. 18, no. 3, pp. 258-264, 2009/05/01/ 2009.
- [27]J. Teizer, B. S. Allread, C. E. Fullerton, and J. Hinze, "Autonomous pro-active real-time construction worker and equipment operator proximity safety alert system," *Automation in Construction*, vol. 19, no. 5, pp. 630-640, 2010/08/01/ 2010.
- [28]H. Yang, D. A. S. Chew, W. Wu, Z. Zhou, and Q. Li, "Design and implementation of an identification system in construction site safety for proactive accident prevention," *Accident Analysis & Prevention*, vol. 48, pp. 193-203, 2012/09/01/ 2012.
- [29]M. Alavi and D. E. Leidner, "Review: Knowledge Management and Knowledge Management Systems: Conceptual Foundations and Research Issues," *MIS Quarterly*, vol. 25, no. 1, pp. 107-136, 2001.
- [30]K. Ruikar, C. J. Anumba, and C. Egbu, "Integrated use of technologies and techniques for construction knowledge management," *Knowledge Management Research Practice*, vol. 5, no. 4, pp. 297-311, 2007.
- [31]M. R. Hallowell, "Safety-knowledge management in American construction organizations," *Journal of Management in Engineering*, vol. 28, no. 2, pp. 203-211, 2012.
- [32]B. Hadikusumo and S. Rowlinson, "Capturing safety knowledge using design-for-safety-process tool," *Journal of construction engineering management*, vol. 130, no. 2, pp. 281-289, 2004.
- [33]L. Y. Ding, H. L. Yu, H. Li, C. Zhou, X. G. Wu, and M. H. Yu, "Safety risk identification system for metro construction on the basis of construction drawings," *Automation in Construction*, vol. 27, pp. 120-137, 2012/11/01/ 2012.
- [34]D. P. Gilkey, J. E. Hautaluoma, T. P. Ahmed, T. J. Keefe, R. E. Herron, and P. L. Bigelow, "Construction work practices and conditions improved after 2-years' participation in the HomeSafe pilot program," *AIHA Journal*, vol. 64, no. 3, pp. 346-351, 2003.
- [35]J. Hinze and G. Wilson, "Moving toward a zero injury objective," *Journal of Construction Engineering Management*, vol. 126, no. 5, pp. 399-403, 2000.
- [36]J. E. Glazner, J. Borgerding, J. Bondy, J. T. Lowery, D. C. Lezotte, and K. Kreiss, "Contractor safety practices and injury rates in construction of the Denver International Airport," *American journal of industrial medicine*, vol. 35, no. 2, pp. 175-185, 1999.
- [37]J. M. Ketola, M. Liuhamo, and M. Mattila, "Application of performance-excellence criteria to improvement of occupational safety and health performance," *Human Factors Ergonomics in Manufacturing Service Industries*, vol. 12, no. 4, pp. 407-426, 2002.
- [38]J. M. Wilson and E. Koehn, "Safety management: problems encountered and recommended solutions," *Journal of construction engineering management*, vol. 126, no. 1, pp. 77-79, 2000.
- [39]V. K. J. I. J. o. P. M. Bansal, "Application of geographic information systems in construction safety planning," vol. 29, no. 1, pp. 66-77, 2011.
- [40]T. W. Loushine, P. Hoonakker, P. Carayon, and M. J. Smith, "The relationship between safety and quality management in construction," in *Proceedings of the Human Factors and Ergonomics Society Annual Meeting*, 2004, vol. 48, no. 16, pp. 2060-2064: SAGE Publications Sage CA: Los Angeles, CA.



**XI International Conference Industrial  
Engineering and Environmental  
Protection 2021 (IIZS 2021)  
October 07-08, 2021, Zrenjanin, Serbia**

---

# **II - Environmental Engineering**

Session 6:

**Health and Environmental  
Engineering**

## TECHNOLOGICAL PROCESSES OF COMPOSTING IN A PUBLIC UTILITY COMPANY (PUC) CITY GREENERY ČAČAK

<sup>1</sup>Dragan Nikolić, Prof. dr Srećko Ćurčić<sup>2</sup>, Mirjana Đoković<sup>3</sup>

<sup>1</sup>Public utility company City greenery Čačak, Serbia

e-mail: [nikolicdrgant@yahoo.com](mailto:nikolicdrgant@yahoo.com)

<sup>2</sup>University of Kragujevac, Faculty technical science in Čačak, Svetog Save 65, Serbia,

e-mail: [srecko.curcic@ftn.kg.ac.rs](mailto:srecko.curcic@ftn.kg.ac.rs)

<sup>3</sup>City administration Čačak, e-mail: [mirjana.djoovic@cacak.org.rs](mailto:mirjana.djoovic@cacak.org.rs)

**Abstract:** Composting of organic waste is an exotiable process in which the organic substrate is subject to anaerobic and aerobic biodegradations under the natural community of microorganisms, as well as specialized microorganisms - technology in conditions of increased temperature and humidity. The last achievements in composting organic waste are based on the application of efficient microorganisms (EM) technology that accelerates the composting process, preventing unpleasant fragrances, suppressing pathogenic bacteria and at the same time increase the quality of the obtained compost. The work of composting in the public utility company City greenery Čačak were given to this paper.

**Keywords:** composting, specialized microorganisms, environmental protection

### INTRODUCTION

The compost is produced from waste raw materials in controlled extensive aerobic conditions. The most active organisms in the composting process are: bacteria, mushrooms and other microorganisms. These microorganisms are present in: food waste, land, leaves, grass. The large amount of biodegradable waste is collected in maintaining green areas in cities. The waste is collected in public urban and suburban areas in Čačak. These jobs work employees in the city of Public Utility Companies (PUC) greenery from Čačak. The collection of leaves and grass is performed with a vacuum cleaner of 10 m<sup>3</sup> [1]. The type of biodegradable material varies throughout the year, such as leaves, peeled grass, weeds, circumcised leaves and sawdust. The choice and separation of biodegradable waste is performed by field workers in the sources of raw material production. After manual selections, the raw materials are delivered at the composting location, where raw materials are measured. The selected crude material can be used for heating or composting. The composting process is about 7 months. If there are fewer wood material, the process is completed in 4 months.

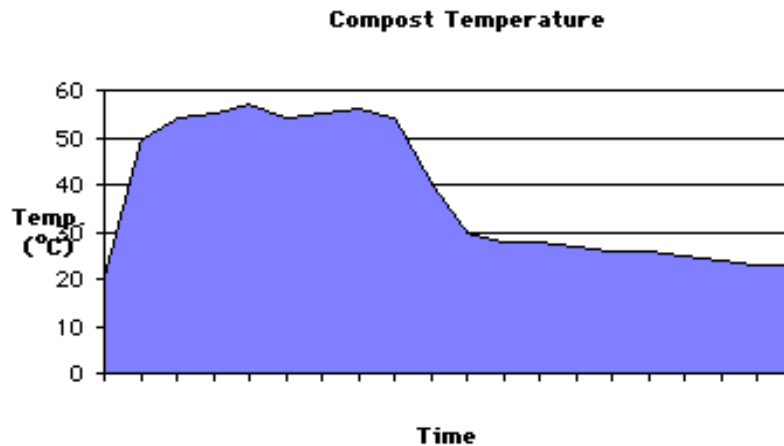
The composting process is [1]:

- Collection of green waste
- forming a pile of compost
- Adding microorganisms and moisture (moisture should reach about 30% to 40%)
- Temperature control and air presence
- Control pH
- Chemical analysis of compost
- Packaging and delivery.

### MATERIAL AND METHODS

#### Composting phases

Fermentation of organic green waste with the application of effective microorganisms takes place in several phases, which characterize appropriate biochemical processes (Figure 1): I - Anaerobic, II - aerobic, thermophilic, III - cooling, IV - maturation. Stadiums from I to III last for several weeks and days and IV stadium - a few months.



**Fig. 1.** Composting phases [2]

In composting processes, anaerobic conditions should be provided and the presence of air should be provided. In the presence of larger air, more intensive oxidative processes are created higher temperature (over 45<sup>0</sup> C) [3] and create conditions for the production of acetic acid. In conditions of such increased temperature, unwanted processes are more intense. In green waste with insufficient amount of lactic acid, conditions are created for the development of some bacteria that are unwanted. Such composted materials can be almost unusable.

#### **Composting in a Public Utility Company (PUC) City greenery Čačak**

In the process of maintaining green areas, a large amount of biodegradable waste is collected in the city (in the amount of about 1000 m<sup>3</sup> [4] a year in Čačak, which can be composted). Waste is collected in public urban and suburban areas in Čačak, and these tasks work PUC City Greeri Čačak. The collection of leaves is performed with 10 cubic meters of vacuum cleaners. The raw materials are collected during the year and are: leaf, grass, weed, shrubs - made of branches and sawdust. After collecting and appropriate transport, the raw material is delivered in composting the fields in which it is recorded and executed. In composting processes, it is necessary to include mixing machines and piles of watering. This composting process is 4-6 months. If smaller wooden materials and external temperatures are higher, the composting process ends about 4 months.

When launching a pile of composting, the material should be added in layers to ensure proper mixing. Organic waste such as leaves, grass and parts of plants are first placed on the bottom in a layer of 20 to 25 cm. This layer should be moistened with water. Materials that contain any type of pesticides should not be used. When laying layers reach the top (about 1.0 m), the crowd should cover the earth or mature compost with a layer. Remember to be added to microorganisms EM. If there is insufficient nitrogen for quick decomposition in composting processes, a fertilizer that has high nitrogen (up to 30%) should be added that accelerates composting. About 1/2 cup (100 g) in nitrogen fertilizers should be added to every 10 kilogram of leaves that are shrinking manually. C / N ratio determines how long the decomposition process will last. For quick composting, initial ratio C / N is about 20 or 30: 1. If the initial ratio is above 50, the process is considered slow.

Maintaining a composted mixture should be moist, because it is one of the preconditions for faster deterioration. Unpleasant odors are created due to adding larger quantities of wet material or due to excessive wetting. If the compost material is properly mixed and properly worn with a composting agent, a bunch of compost will not create unpleasant odors. Using microorganisms, EM (Naturalnie Aktywne) will eliminate unpleasant odors. In the middle of the compost field, temperature must not be greater than 70<sup>0</sup> C. If the crowd is not heated enough, it means that there is not enough nitrogen or oxygen, or is too wet, or too wet or too dry. Converting the crowd, it exposes a higher inflow of air, and in addition, the recognizable part of the material is moved to the central part where the process is heated. The composting process is considered to be completed when the overturning no longer creates heat in the crowd. When spilled in the crowd, adding fresh composting material is recommended.





**Fig. 2.** First batch in forming compost [4]



**Fig. 3.** The temperature of the compost crowd at the end of the fermentation [4]

To speed up the phase of anaerobic composting, a bunch of compost is compacted (using skipping, image 4) and due to air extrusion in a better anaerobic fermentation. The monitoring of the composting process included try time intervals. The final layer of the first compost of the first crowd was established using a biodegradable waste since 2018 in a layer of 100 cm thick. For a smooth flow of anaerobic composting phase, a bunch of compost is covered with thermal insulation foil. The first bunch of compost was completed on 27/06/2019. The amount of organic biodegradable waste collected from public areas in 2019 depended on agroecological conditions during the year (amount of precipitation). After seven days, the first pile of composts at a depth of 35 cm was measured with temperatures of 50<sup>0</sup> C, and in the next fifteen days the compost temperature was 42<sup>0</sup> C and was held by the end of August. In anaerobic phase of composting, there was a gradual reduction in the amount of compost crowds, etc. There was a reduction in the height of the compost with 1.00 m at 0.90 m. A bunch of compost was discovered 09/09/2019. Mixing in a pile of compost was performed using the mechanization. In addition, the compost was refined with water 16/09/2019, after that. In the aerobic phase, the composted mixture was dark brown, which was shown in Figure 5. At this phase of composting, the average sample of raw compost was taken for basic chemical analyzes. Based on the results of the chemical analysis of crude compost, it can be concluded that its pH is poorly alkaline, this medium carbonate, with a very high content of humus and total nitrogen. Easily accessible phosphorus and easily accessible potassium is extremely high and amounts to about 1.50%. The beginning of the formation of another bunch of compost was created at the end of June 2019.

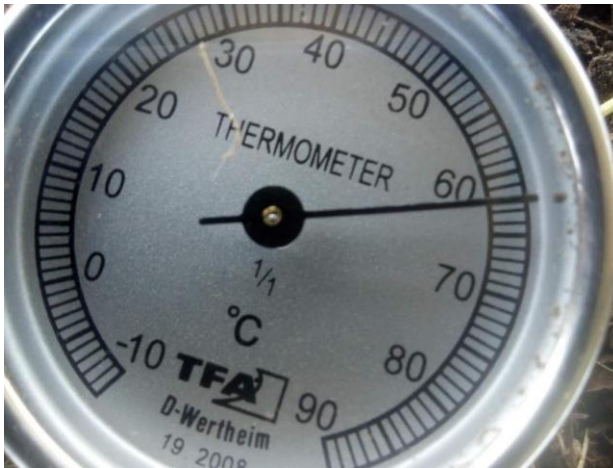


**Fig. 4.** Aeration of compost crowds [4]



**Fig. 5.** Fermented composted mass per first Aeration [4]

In the second compost crowd, the organic biodegradable green biomass was used by green biomass and organic waste since 2018. The procedure for the formation of a composted EM natural active was identical to the first composted crowd. The second bunch of compost was completed on 23/07/2019.



**Fig. 6.** Temperature of another batch in phase of anaerobic fermentation [4]



**Fig. 7.** Batch of compost 1-2 -3 (right to on the Left side) [4]

The heat isolation was removed on 4/06/19 and a crowd compost is composed. The beginning of the formation of the third composting was done in mid-July 2019, the composition of organic biodegradable waste consists of weeds, part of the dry grass and mild organic waste since 2018, all composting activities were identical to previous composting. The formation of the third composted crowd was ended on 12/08/2019. [4] The following temperatures measured in the anaerobic phase are: 29/07/2019-60 °C, 30/07/2019-60 °C, 31/07/2019-58 °C, 01/08/2019-55 °C, 02/08/2019-55 °C, 05/08/2019-55 °C, 06/08/2019-50 °C, 12/08/2019-45 °C, 26/08/2019-40 °C. Foil detection with additional irrigation and mechanized treads was performed on 29/08/2019.

### Ecological aspects

The compost can be used for:

#### 1. Prevention to contaminated

The new composting technology, known and as a bioremediation compost, is now used to restore contaminated country.

#### 2. Control of plant and animal diseases

Composting is used to increase yields in organic production. Research has shown that compost is used to stop the expansion of pests. The compost can help farmers save money, reduce the use of pesticides, protect natural resources ...

#### 3. Control erosion

The compost is used to improve plant growth. The compost enriches the earth and reducing the erosion and outflow of nutrients from the country, provides support against diseases and pests that endanger plants.

#### 4. Renewal of marshes and revitalization of forest habitats

The compost can be used for afforestation, renovation of the wetlands and revitalization of habitats.

## RESULTS AND DISCUSSION

The results of the analysis of the produced compost are given in Table 1.

The values of the laboratory analysis of the compost sample are: pH is 7.28 poorly alkaline, CaCO<sub>3</sub> in (%) is 4.22 - which is a medium carbonate, the Humus content in (%) is 26.52 - high, Nitrogen in (%) is 1.33 - very high, P<sub>2</sub>O<sub>5</sub>/mg/100 g is 13,36, and K<sub>2</sub>O /mg/100 g 22,6.

In addition to basic agrochemical indicators, it is necessary to control the level of heavy metals in compost. The compost in which heavy metals exceed the norm intended for fertilizers, can be used in parks, forests and plots next to roads.

**Table 1.** Results of agrochemical analysis of the compost obtained [4]

FRUIT RESEARCH INSTITUTE Čačak		Archived _____				
		Sample compost				
		City greenery Čačak				
ČAČAK _____						
No: _____						
<b>LABORATORY REPORT ON CHEMICAL ANALYSIS OF LAND</b>						
Identification number: _____						
Simple Owner: _____						
Date of analysis: _____						
Land properties	pH	CaCO <sub>3</sub>	Humus content	N	P <sub>2</sub> O <sub>5</sub>	K <sub>2</sub> O
Sample	in KCl <4,5 Very sour 4.6-5.5 Sour 5.6-6,5 Poorly sour 6.6-7.2 Neutral 7.2-8.0 Poorly alkaline	(%) 0% no carbonate 0.1-2% poor carbonate 2-5% medium carbonate 5-10% carbonate > 10% high carbonate	(%) <2% low 2-5% medium 5-8% high > 8% very high	(%) <0.3% low 0.1-0.2% medium 0.2-0.4 high > 0.4% very high	(mg/100 gr) <0.5 very low 5-10 Low 10-15 Middle 15-25 good 25-40 tall 45-50 very tall > 50 Harmful	(mg/100 gr) <5mg-very low 5-10 Low 10-15 Medium low 15-25 Good security 25-40 tall 40-50 Ceima tall > 50 Harmful
Compost	7.28	4,22	26,52	1,33	133,46	226
Responsible person: Dr Mira Milinkvić				Director: Dr Milan Lukić		

Application of effective microorganisms in composting organic waste meets sanitary hygiene, environmental protection and an integrated plant protection system. The application of compost is an effective measure in rehabilitation and improvement of devastated land and their return to a situation for agricultural use.

The compost can be entered into the country as organic fertility every 3 - 4 years, in quantities of 5-10 t / ha.

The obtained compost of organic green waste is brown in black (figure 8). The existing organic green waste in the composting process loses unpleasant odors, gradually deodorizes and at the end of this process, the compost received the fragrance of the country.



Fig. 8. Composition results in PUC City Greeri Cacak

## CONCLUSION

Based on realized activities (1/5/2019- 30/09/2019), the following is respected in composting biodegradable organic waste in PUC Čačak city greenery:

- Collected biomass waste collected by PUC Čačak city greenery, is selected and prepared for composting with appropriate mixing,
- In a pile of composting, efficient microorganisms (EM) that enable proper composting of prepared mass,
- The compost mass was regularly stirred and temperature measurement was made in it,
- The amount and quality of compost obtained from biodegradable waste depends on the intake of raw materials for composting.

Composting procedures are divided into two phases - in a covered area (anaerobic fermentation) 2 to 4 months depending on the fraction and the quality of the organic mass used for composting. After the first phase, the second phase (aerobic) performed in a covert space for composting space, 2 to 3 months.

Based on chemical analyzes of the compost in accordance with the appropriate processes and the phase of maturation from: the first, second and third compost, it is stated that it can be made quality biodegradable organic waste in PUC city greenery Čačak.

**Acknowledgment:** This paper is supported by the Ministry of Education, Science and Technological Development of the Republic of Serbia, and these results are part of the Grant No. 451-03-68/2020-14/200132 with University of Kragujevac-Faculty of Technical Sciences Čačak.

## REFERENCES

- [1] Data - Publicly communal undertaking city greenery Čačak, (2017, 2018, 2019.)
- [2] Ivana Ilic-Krstic, Jasmina Radosavljevic, Amelija Đorđević: Composting as a form of biodegradable waste treatment, Conference: XVII Scientific conference man and work environment - "Management of communal systems and environmental protection, December 2017.
- [3] Boldrin, A., JK. Andersen, J. Moller, T.H. Christensen I E. Favoino. Composting and compost utilization: accounting of greenhouse gases and global warming contributions. Waste Management I Research. 27:800-812, 2009.
- [4] Srećko Ćurčić: Study for the project: "Rational sustainable use of waste biomass in the PUC city greenery Čačak", Faculty of Technical Sciences in Čačak, December, 2019.

## DETERMINATION OF ADR TRANSPORT CONDITIONS APPLICABLE TO METHYL TERT-BUTYL ETHER AS A LIQUID FLAMMABLE PETROCHEMICAL

Matilda Lazić<sup>1</sup>, Miodrag Kovačević<sup>1</sup>

<sup>1</sup>Technical College of Applied Sciences in Zrenjanin, Zrenjanin, Serbia

e-mail: [matildalazic@outlook.com](mailto:matildalazic@outlook.com), [miodrag.kovacevic.zr@gmail.com](mailto:miodrag.kovacevic.zr@gmail.com)

**Abstract:** In this work, the Agreement concerning the International Carriage of Dangerous Goods by Road (ADR) transport conditions applicable to Methyl tert-butyl ether (MTBE), as a significant liquid flammable petrochemical, were determined. It is assumed that MTBE manufactured by "HIP Petrohemija" from Pančevo represents dangerous goods in road transport because it belongs to Class 3 - Flammable liquids. It is also assumed that the safety data sheet of the MTBE (selected manufacturer) contains basic information on the conditions of ADR transport. The data from the MTBE safety data sheet are not sufficient for a comprehensive and detailed determination of the permitted transport conditions of MTBE, but they are valid guidelines. It is necessary for the manufacturer to take into account all the provisions prescribed in Table A: Dangerous goods List, to perform safe or only permitted transport of MTBE by road. Determining and applying the permitted ADR transport conditions of MTBE also contributes to reducing the risk of chemical accidents, as side effects with potentially catastrophic consequences for human life and health, work, and the environment.

**Key words:** ADR, flammable liquids, MTBE, safety data sheet, dangerous goods

### INTRODUCTION

Methyl tert-butyl ether (MTBE) is an additive for unleaded gasoline and also an indispensable addition to the so-called, reformulated motor gasoline [1-4]. The addition of MTBE increases the octane number of gasoline and improves engine performance. MTBE by function is an additive oxygenate, which gives conventional motor gasoline an increased oxygen content, i.e. allows better fuel combustion and provides an anti-knock effect [1-4]. MTBE is produced in "HIP Petrohemija" from Pančevo, by the reaction of isobutene and methanol [2]. MTBE is also used as a raw material for numerous syntheses in the secondary petrochemical industry, as a solvent in the chemical industry, etc. However, MTBE, both in the form of the final product and in the form of raw material for further synthesis, is a dangerous and harmful substance [1,3,5-7]. Therefore, MTBE becomes a dangerous good and the provisions of the Agreement concerning the International Carriage of Dangerous Goods by Road (ADR) must be applied for its safe transport by road [8].

In this work, the ADR transport conditions applicable to MTBE, as a significant liquid flammable petrochemical, were determined. It is assumed that MTBE manufactured by "HIP Petrohemija" from Pančevo, represents dangerous goods because it belongs to Class 3 of dangerous goods - Flammable liquids. It is also assumed that the safety data sheet of the MTBE (selected manufacturer) contains only basic information on the conditions of ADR transport. For the comprehensive determination of permitted MTBE transport conditions, all the provisions prescribed in Table A: Dangerous goods list [8] must be applied.

### DANGEROUS GOODS LIST

The basic instructions for the use of ADR are Table A: Dangerous goods list in numerical order of UN numbers (Table A) from Chapter 3.2. - Dangerous goods list [8]. Table A lists dangerous goods in numerical order according to UN numbers. In addition to the provisions referred to or given in Table A, the general requirements of each Part, Chapter, and/or Section of ADR are to be observed. These general requirements are not given in the tables. When a general requirement is contradictory to a special provision, the special provision prevails [8].

## Explanations of Table A

As a rule, each row of Table A [8] deals with the substance(s) or article(s) covered by a specific UN number. However, when substances or articles belonging to the same UN number have different chemical properties, physical properties, and/or carriage conditions, several consecutive rows may be used for that UN number. Each column of Table A is dedicated to a specific subject. The intersection of columns and rows (cell) contains information concerning the subject treated in that column, for the substance(s) or article(s) of that row [8,9]:

- The first four cells identify the substance(s) or article(s) belonging to that row (additional information in that respect may be given by the special provisions referred to in Column (6).
- The following cells give the applicable special provisions, either in the form of complete information or in coded form. The codes cross-refer to detailed information that is to be found in the Part, Chapter, Section, and/or Subsection indicated in the explanatory notes below. An empty cell means either that there is no special provision and that only the general requirements apply, or that the carriage restriction indicated in the explanatory notes is in force.

The applicable general requirements are not referred to the corresponding cells. The explanatory notes below indicate for every column the Part(s), Chapter(s), Section(s), and/or Sub-section(s) where these are to be found [8]. Explanatory notes for each column of Table A [8] are given in Chapter 3.2. [8] and have been applied in this work.

## DETERMINATION OF ADR TRANSPORT CONDITIONS OF MTBE BASED ON DATA FROM SAFETY DATA SHEET

For the general determination of permitted transport conditions of MTBE manufactured by “HIP Petrohemija” from Pančevo, the safety data sheet was used [7]. The analysis of the data from Chapter 14: Transport data [7] showed that the manufacturer recommends the conditions of ADR transport. The UN number MTBE 2398 is stated. Based on it, the general transport conditions are determined. The Class of dangerous goods (Transport hazard class): Class 3 - Flammable liquids [10]. Label model number 3 – Specimen label for the MTBE is shown in Figure 1. [7].



**Fig. 1.** The specimen label for MTBE

The packing group is II. The MTBE in transport does not pose a danger to the environment. In the MTBE safety data sheet [7] the manufacturer stated special precautions for the users in case of ADR transport:

- subject to transport rules,
- classification code: F1,
- limited quantities: 1 l,
- hazard identification number: 33,
- the appearance of an orange-colored plate,
- transport in bulk: not applicable.

The recommended transport conditions from the MTBE safety data sheet [7] are by the valid regulations in road traffic, in all UN member states, which are signatories to the ADR (which is also the case for the Republic of Serbia). However, the safety data sheet does not provide more detailed explanations of the emphasized transport conditions, which indicates that the provisions of Table A [8] (for MTBE UN number) must be included.

## DETERMINATION OF ADR TRANSPORT CONDITIONS OF MTBE BASED ON REQUIREMENTS FROM TABLE A

This Chapter will interpret the provisions listed in the columns of Table A [8] for UN number 2398, which is assigned to a dangerous substance called Methyl tert-Butyl ether (MTBE).

Column 1: UN number (Chapter 1 [8]) and Column 2: Name and description (Section 3.1.2. [8]). UN number 3298 covers only one dangerous substance, whose name and description is: Methyl tert-Butyl ether (MTBE).


Column 3a: Class (Subchapter 2.2 [8]). An MTBE with UN 2398 belongs to Class 3 - Flammable liquids. An MTBE is a dangerous good in transport, a representative of flammable liquids (specifically, petrochemicals by origin), and causes danger in transport, following Class 3.

Column 3b: Classification code (Subchapter 2.2 [8]). For MTBE, classification code F1 is given, which means the division of substances within Class 3. According to classification code F1, MTBE belongs to flammable liquid substances with a flashpoint of not more than 60°C.

Column 4: Packing group (Subsection 2.1.1.3 [8]). For packing purposes, substances are assigned to packing groups, following the degree of danger they present. Packing group II: Substances presenting medium danger.

Column 5: Labels (Section 5.2.2 [8]). Label model number is 3 for the MTBE. A Specimen label for Class 3, to which MTBE belongs, is given in Table 1. [8].

**Table 1.** Class 3 – Flammable liquids

Label model number	Symbol and symbol color	Background	Figure in the bottom corner (and figure color)	Specimen labels
3	Flame – black or white	Red	3 (black or white)	

Column 6: Special provisions (Subchapter 3.3 [8]). A blank column 6 for MTBE means that no special provisions apply.

Column 7: Limited and excepted quantities.

Column 7a: Limited quantities (Subsection 3.4 [8]). The column states 1L. The quantity limit applicable to inner packing, established for MTBE, is 1 l.

Column 7b: Excepted quantities (Subsection 3.5.1.2 [8]). Dangerous goods, which may be carried as excepted following the provisions of this Subsection list using of an alphanumeric code as follows in Table 2. [8]. The alphanumeric code read for MTBE is E2.

**Table 2.** Excepted quantities

Code	Maximum net quantity per inner packaging (in ml for liquids)	Maximum net quantity per outer packaging (in ml for liquids)
E0	Not permitted as Excepted quantity	
E1	30	1000
E2	30	500
E3	30	300
E4	1	500
E5	1	300

Column 8: Packing instructions (Section 4.1.4 [8]).

P001 – Packing instruction (liquids) for MTBE. Single/Composite packing. Defines the type of inner and outer packaging, outer packaging following the packing group. Maximum quantities are given.

IBC02 - Instructions for IBC packaging. The following IBCs for MTBE can be used: metal, rigid plastic, composite.

Column 9a: Special packing provisions (Section 4.1.4 [8]). MTBE is not subject to special packing and packing provisions. All general provisions of Subchapter 4.1 (Use of packaging, IBC, and large packing [8]) must be applied.

Column 9b: Mixed packing provisions (Section 4.1.10 [8]). Special provisions for mixed packing apply to MTBE. When mixed packing is permitted following the provisions of Section 4.1.10 [8], different dangerous goods or dangerous goods and other goods may be packed together in combination packaging conforming to Subsection 6.1.4.2.1, provided that they do not react dangerously with one another and that all other relevant provisions of this Section are complied with. Provision M19 applies to MTBE. May - in quantities not exceeding 5 l per inner packaging - be packed together in a combination packaging conforming to Subsection 6.1.4.2.1 [8]:

- with goods of the same class covered by other classification codes or with goods of other classes, when mixed packing is also permitted for these,
- with goods that are not subject to the requirements of ADR, provided they do not react dangerously with one another.

Column 10: Portable tanks - Instructions (Subsection 4.2.5.2 and Section 7.3.2 [8]). For MTBE the instructions for determining the T7 portable tank apply. Based on T7, other permitted instructions for portable tanks have been defined. In addition to the T7, other portable tanks can be used, which have higher minimum test pressures, higher tank body wall thickness, and stricter requirements for bottom openings and pressure relief devices than those given in the basic instructions.

Column 11: Portable tanks - Special provisions (Subsection 4.2.5.3 [8]). For ADR transport MTBE, special provisions are defined for portable tanks, which must be applied in addition to the basic ones from the T7 Instruction. Special provisions for portable tanks are marked with alphanumeric codes beginning with the letters "TP". The provision TP1 applies to MTBE: The defined filling level must not be exceeded (calculation form is given in Subsection 4.2.5.3 [8]).

Column 12: ADR tank - Tank code (Subchapter 4.3 [8]). A rationalized approach for tank coding applied to MTBE is given in Table 3. [8].

**Table 3.** A rationalized approach for tank coding applied to MTBE

Tank code	Group of permitted substances		
	Class	Classification code	Packing group
LGBF	3	F1	II Vapor pressure at 50°C ≤ 1,1 bar

Column 13: ADR tank - Special provisions (Sections 4.3.5, 6.8.4 [8]). No special provisions for the MTBE are defined.

Column 14: Vehicle for tank carriage (Subsection 9.1.1.2 [8]). FL-type vehicles are required for MTBE transport. FL vehicle is a vehicle intended for the carriage of liquids having a flash-point of not more than 60°C fixed tanks or demountable tanks with a capacity exceeding 1 m<sup>3</sup> or in tank-containers or portable tanks with an individual capacity exceeding 3 m<sup>3</sup>.

Column 15: Transport category (Tunnel restriction code) (Subsections 1.3.6, 8.6 [8]). For vehicles carrying MTBE, the Tunnel restriction code of the whole load D/E applies, as shown in Table 4.

**Table 4.** MTBE Tunnel restriction code

Tunnel restriction code of the whole load	Restriction
D/E	Tank carriage: Passage forbidden through tunnels of category D and E; Other carriages: Passage forbidden through tunnels of category E.

Column 16: Special provisions for carriage – Packages (Section 7.2.4 [8]). No special provisions are prescribed for MTBE.

Column 17: Special provisions for carriage – Bulk (Section 7.3.3 [8]). No special provisions are prescribed for MTBE.



Column 18: Special provisions for carriage – Loading, unloading, and handling (Subsection 7.5.11 [8]). No special provisions are prescribed for MTBE.

Column 19: Special provisions for carriage – Operation (Subchapter 8.5 [8]). In addition to the requirements of Subchapters 8.1 to 8.4, when reference is made to them in Column (19), the following requirements shall apply to the carriage of the substances or articles concerned. In the event of a conflict with the requirements of Subchapters 8.1 to 8.4, the requirements of this Subchapter shall take precedence. An additional requirement S2 is prescribed for MTBE. S2 - Additional requirements concerning the carriage of flammable liquids or gases:

- Portable lighting apparatus: The load compartment of closed vehicles carrying liquids having a flash-point of not more than 60 °C or flammable substances or articles of Class 2, shall not be entered by persons carrying portable lighting apparatus other than those so designed and constructed that they cannot ignite any flammable vapors or gases which may have penetrated the interior of the vehicle.
- Operation of combustion heaters during loading or unloading: The operation of combustion heaters of vehicles of FL-type is forbidden during loading and unloading and at loading sites.
- Precautions against electrostatic charges: In the case of vehicles of FL-type, a good electrical connection from the vehicle chassis to earth shall be established before tanks are filled or emptied. In addition, the rate of filling shall be limited.

Column 20: Hazard identification number (Subsection 5.3.2.3 [8]). The Hazard identification number for the MTBE is 33. Identification number 33 has the following meaning: Highly flammable liquid (flash-point below 23 °C).

#### **COMPARATIVE ANALYSIS OF ADR TRANSPORT CONDITIONS OF MTBE FROM SAFETY DATA SHEET AND TABLE A**

The safety data sheet of the dangerous substance MTBE, manufactured by “HIP Petrohemija” from Pančevo [7], contains a set of basic provisions related to the conditions in road carriage. In addition to UN number 2398, the following conditions are specified, which determine the ADR transport of MTBE: name of goods in carriage, class, labels, packing group, classification code, limited quantities, hazard identification number, the appearance of an orange-colored board [7]. It can be considered that the data on the permitted transport conditions of MTBE [7] are in line with the requirements of the relevant national regulations but also with the requirements of ADR [8].

It must be emphasized that the MTBE may be transported exclusively, following the provisions set out in the safety data sheet. However, the provisions of ADR transport for MTBE, listed in the safety data sheet, are not explained in detail. The data from the safety data sheet [7] indicate a link with the relevant regulations, for a closer interpretation of the same. The classification of MTBE, which is stated in the safety data sheet, was performed according to the methodology for ADR classification of dangerous goods, i.e., following its physical, chemical properties (which further cause a corresponding hazard in the carriage).

For a comprehensive and precise determination of the permitted ADR transport conditions of MTBE, it is necessary to interpret the general and special provisions given in all 20 columns of Table A. In doing so, it is necessary to determine: when only the general provisions apply; when general and additional provisions apply; when special provisions are applied as valid advantages.

Based on the data from the safety data sheet and also from Table A, the MTBE is classified in Class 3 of dangerous goods - Flammable liquid substances. If observed in more detail, based on the Hazard identification number, the MTBE is a highly flammable liquid (flash-point below 23°C), which is following with the data from the specification sheet [6].

#### **CONCLUSION**

MTBE manufactured “HIP Petrohemija” from Pančevo represents flammable liquid, dangerous goods in ADR transport. According to the origin, MTBE is a petrochemical product (petrochemical), while according to the hazard identification code, i.e. according to physical and chemical properties, the

MTBE is a representative of flammable liquids. Hazards from the MTBE in transport are defined following the corresponding Class of dangerous goods. The Class of dangerous goods predetermines the severity of the general and/or special conditions of the MTBE transport by road.

The permitted ADR transport conditions applicable to MTBE are determined by interpreting and crossing all available data from Table A. The MTBE safety data sheet contains general conditions of transport, which are in line with the requirements of national regulations and ADR but can only represent guidelines, which the manufacturer provides to transport companies. To comprehensively consider the illegal conditions and restrictions, it is necessary to systematically consider the ADR provisions for the specific case of dangerous goods, as well as other transport conditions. Determination and strict application of permitted conditions of ADR transport contribute to increasing the safety of the chemical - MTBE (as a flammable liquid petrochemical) during its transport. Reducing the risk of adverse events during the transport of the chemical causes an increase in the safety of the vehicle and the vehicle crew.

Determining and applying the permitted ADR transport conditions of the MTBE also contributes to reducing the risk of chemical accidents, as side effects with potentially catastrophic consequences for human life and health, work, and the environment.

The Further workflow could include determining the RID transport conditions of MTBE and comparing them with ADR transport conditions; more detailed consideration of the provisions related to tanks and crews of vehicles for the transport of liquid flammable substances, etc.

## REFERENCES

- [1] Janović, Z., Petroleum and petrochemical processes, and products, Goma, Zagreb, Republic of Croatia, 2011
- [2] Petrochemical products, HIP Petrohemija, Pančevo. Available at <https://www.hip-petrohemija.com/prodaja/proizvodi/bazni-proizvodi.233.html>
- [3] MTBE oxygenate, and motor gasoline, Energy information Agency, March 2000. Available at <https://www.eia.gov/outlooks/steo/special/pdf/mtbe.pdf>
- [4] Methyl Tertiary Butyl Ether (MTBE), Overview, United States Environmental Agency (EPA), February 2016. Available at <https://archive.epa.gov/mtbe/web/html/>
- [5] Farid, E., A., Toxicology and human health effects following exposure to oxygenated or reformulated gasoline, Toxicology Letters, Vol.123, No.2–3, pp. 89-113, 2001.
- [6] MTBE specification sheet, HIP Petrohemija, Pančevo. Available at [https://www.hip-petrohemija.com/upload/documents/proizvodna\\_linija/etilen/MTBE\\_s.pdf](https://www.hip-petrohemija.com/upload/documents/proizvodna_linija/etilen/MTBE_s.pdf)
- [7] MTBE Safety Data Sheet, HIP Petrohemija, Pančevo. Available at [https://www.hippetrohemija.com/upload/documents/proizvodna\\_linija/bezb\\_list/SDS\\_MTBE\\_srp\\_06072018.pdf](https://www.hippetrohemija.com/upload/documents/proizvodna_linija/bezb_list/SDS_MTBE_srp_06072018.pdf)
- [8] ECE/TRANS/300: Agreement concerning the International Carriage of Dangerous Goods by Road (ADR), ADR version applicable as from 1 January 2021, Vol.1-2, UNITED NATIONS, New York and Geneva, 2020. Available at <https://unece.org/transportdangerous-goods/adr-2021-files>

## RID CARRIAGE CONDITIONS OF FLAMMABLE LIQUID, N.O.S.

Matilda Lazić<sup>1</sup>, Miodrag Kovačević<sup>1</sup>, James G. Speight<sup>2</sup>, Ljiljana Radovanović<sup>3</sup>

<sup>1</sup>Technical College of Applied Sciences in Zrenjanin, Zrenjanin, Serbia

<sup>2</sup>CD & W Inc., 2476 Overland Road, Laramie, WY 82070-4808, USA

<sup>3</sup>University of Novi Sad, Technical Faculty "Mihajlo Pupin", Zrenjanin, Serbia

e-mail: [matildalazic@outlook.com](mailto:matildalazic@outlook.com),

e-mail: [miodrag.kovacevic.zr@gmail.com](mailto:miodrag.kovacevic.zr@gmail.com)

**Abstract:** The paper identifies the RID transport conditions of the Flammable Liquid, N.O.S. It is assumed that the permitted RID transport conditions of the Flammable Liquid, N.O.S. can be determined based on the general transport conditions, for a particular class of dangerous good, and from the data given in Table A: Dangerous Goods List (if UN number is known). By crossing the data from Table A and taking into account the general conditions, the transport conditions of Flammable Liquid, N.O.S. are determined, and they represent the only permitted conditions under which this dangerous good can be transported by rail. The degree of danger, which is represented by the Flammable liquid, N.O.S. in the carriage, depends primarily on its physical and chemical properties, but also on the type and safety of railway cars (tanks) and the fulfillment of the prescribed carriage conditions. Transport of substance - Flammable liquid, N.O.S. in railway traffic according to the allowed RID conditions, contribute to the reduction of the risk of transport incidents and chemical accidents.

**Key words:** RID, Flammable Liquid, N.O.S, dangerous good, transport safety

### INTRODUCTION

Flammable liquids are widespread dangerous substances, primarily in the chemical and petrochemical industries. In industry, they can represent raw materials for a wide range of syntheses, process chemicals (e.g. solvents), intermediates, and end products. Examples of flammable liquids used in everyday life are motor fuels of petroleum origin (e.g. gasoline, diesel, etc.), liquid industrial fuels, certain chemicals for disinfection and household chemicals, etc. Flammable highly viscous liquids are components for coatings/paints/adhesives/polymers, etc.

Flammable liquids, like dangerous goods, are most often transported in international transport by road or rail [1-3] following the relevant international and national regulations.

The paper identifies the RID transport conditions of the Flammable Liquid, N.O.S. It is assumed that the permitted RID transport conditions of the Flammable Liquid, N.O.S. can be determined based on the general transport conditions, for a particular class of dangerous good, and from the data given in Table A: Dangerous Goods List in UN number order (hereinafter: Table A) [3]. It was also assumed that by interpreting the data from Table A and crossing them with the general conditions, a set of complete, permitted RID carriage conditions of the Flammable Liquid, N.O.S.

### FLAMMABLE LIQUIDS-BASIC TERMS, DEFINITION, AND DIVISION

The degree of danger posed by a flammable liquid depends primarily on the properties of the liquid as well as the conditions and manner of use. The properties of liquids that are important for determining the degree of danger in the carriage are the point of ignition and the point of self-ignition, the degree of volatility, the range of flammability (explosiveness). The National Standard (SRPS Z.CO.007) and the Regulation on technical and other requirements for materials and goods according to fire behavior [4] define flammable liquids, liquids, or mixtures of liquids without or with suspended or dissolved solids, which at a temperature of 50°C they have a vapor pressure lower than 3 bar (3kPa), and whose vapors ignite in a suitable relationship with the air in the presence of an ignition source (flame, spark). According to the ignition temperature and boiling temperature, flammable liquids are divided into highly flammable liquids and flammable liquids, which is following the CLP Directives [7]. Highly flammable liquids are those liquids that have an ignition temperature below 38 °C and whose vapor pressure does not exceed 3 bar.

Highly flammable liquids form group I of flammable liquids whose ignition temperature is below 38°C. They are divided into three subgroups [4-7]:

- IA- liquids whose ignition temperature is below 23°C and boiling point below 38°C,
- IB- liquids whose ignition temperature is below 23°C and a boiling point above 38°C,
- IR liquids with ignition temperature from 23°C to 38°C.

Flammable liquids are those liquids that have an ignition temperature of 38°C and above. Flammable liquids form groups II and III of flammable liquids, as stated [4-7]:

- Group II consists of liquids whose ignition temperature is from 38°C to 60°C,
- Group III consists of liquids whose ignition temperature is 60°C and higher. They are divided into two groups: IIIA-liquids whose ignition temperature is from 60°C to 93°C; IIIB - liquids whose ignition temperature is 93°C or higher.

### **DANGEROUS GOODS OF CLASS 3-FLAMMABLE LIQUIDS**

The heading of Class 3 covers substances and articles containing substances of this Class which:

- are liquids according to subparagraph (a) of the definition for "liquid" in 1.2.1 [3];
- have at 50°C a vapor pressure of not more than 300 kPa (3 bar) and are not completely gaseous at 20°C and at standard pressure of 101.3 kPa; and
- have a flash-point of not more than 60°C.

The heading of Class 3 also covers liquid substances and molten solid substances with a flash-point of more than 60°C and which are carried or handed over for carriage whilst heated at temperatures equal to or higher than their flash-point.

The substances and articles of Class 3 are subdivided as follows:

- F-Flammable liquids, without subsidiary hazard and articles containing such substances: F1-Flammable liquids having a flash-point of or below 60 °C; F2-Flammable liquids having a flash-point above 60°C which are carried or handed over for carriage at or above their flash-point (elevated temperature substances); F3-Articles containing flammable liquids.
- FT-Flammable liquids, toxic: FT1-Flammable liquids, toxic; FT2-Pesticides.
- FC-Flammable liquids, corrosive.
- FTC-Flammable liquids, toxic, corrosive.
- D-Liquid desensitized explosives.

### **RID TRANSPORT CONDITIONS OF DANGEROUS GOODS FOLLOWING GENERAL REQUIREMENTS AND TABLE A**

In addition to the provisions referred to or given in the tables of Part 3 - Dangerous goods lists, special provisions and exemptions related to limited and excepted quantities [3], the general requirements of each Part, Chapter, and/or Section are to be observed. These general requirements are not given in the tables. When a general requirement is contradictory to a special provision, the special provision prevails [3].

#### **Generic or “not otherwise specified” (N.O.S.) names**

Taking into account that the subject of this paper is a dangerous good the Flammable Liquid, which contains the name “not otherwise specified” (N.O.S.), the term will be specified.

Generic and “not otherwise specified” proper shipping names that are assigned to special provision 274 or 318 in Column (6) of Table A in Chapter 3.2 [3] shall be supplemented with the technical name of the goods unless a national law or international convention prohibits its disclosure if it is a controlled substance. The technical name shall be a recognized chemical name or biological name, or other names currently used in scientific and technical handbooks, journals, and texts. Trade names shall not be used for this purpose [3].

The name “not otherwise specified” (N.O.S.) appears in columns (1), (2) of Table A, which serves as a starting point for determining the RID carriage conditions of any dangerous goods, according to UN number. Column (1) - UN Number contains the UN number of the generic or N.O.S. entry to which the dangerous substances or articles not mentioned by name shall be assigned following the criteria ("decision trees") of Part 2 [3]. Column (2) - Name and description contain, in upper case characters,

the name of the substance or article, if the substance or article has been assigned its own specific UN number, or of the generic or N.O.S. entry to which it has been assigned following the criteria ("decision trees") of Part 2 [3]. This name shall be used as the proper shipping name or, when applicable, as part of the proper shipping name. A descriptive text in lower case characters is added after the proper shipping name to clarify the scope of the entry if the classification and/or carriage conditions of the substance or article may be different under certain conditions.

### **Explanations on Table A: List of dangerous goods in UN number order**

As a rule, each row of Table A of Chapter 3.2 [3] deals with the substance(s) or article(s) covered by a specific UN number. However, when substances or articles belonging to the same UN number have different chemical properties, physical properties, and/or carriage conditions, several consecutive rows may be used for that UN number.

Each column of Table A is dedicated to a specific subject as indicated in the explanatory notes below. The intersection of columns and rows (cell) contains information concerning the subject treated in that column, for the substance(s) or article(s) of that row [3]:

- The first four cells identify the substance(s) or article(s) belonging to that row (additional information in that respect may be given by the special provisions referred to in Column (6));
- The following cells give the applicable special provisions, either in the form of complete information or in coded form. The codes cross-refer to detailed information that is to be found in the Part, Chapter, Section, and/or Sub-section indicated in the explanatory notes below. An empty cell means either that there is no special provision and that only the general requirements apply, or that the carriage restriction indicated in the explanatory notes is in force.

Explanatory notes for each column of Table A, are given in Chapter 3.2 [3].

### **DETERMINATION OF RID TRANSPORT CONDITIONS OF FLAMMABLE LIQUID, N.O.S. FOLLOWING GENERAL REQUIREMENTS AND TABLE A**

This paper identifies the comprehensive and permitted RID transport conditions based on the interpretation of the general provisions and their intersection with the special provisions in Table A [3], which apply to the Flammable Liquid, N.O.S.

Column (1) "UN number"[3]. UN number 1993 recognizes dangerous good the Flammable Liquid, which contains the name "not otherwise specified" (N.O.S.). Shipping name is Flammable Liquid, N.O.S.

Column (2) "Name and description" [3]. This column contains the name of the substance FLAMMABLE LIQUID written in capital letters, i.e. the name N.O.S., in which the dangerous substance is classified following the criteria of Part 2 ("decision trees"). This name must be used as the official name for the transport (shipping name). There is no technical name next to the name, which would further specify the name/description.


Column (3a) "Class" [3]. This column contains the class number, the definition of which includes dangerous substances. This class number is assigned following the criteria of Chapter 2.2 [3]. The Flammable Liquid, N.O.S. belongs to Class 3 - Flammable liquids.

Column (3b) "Classification code" [3]. This column contains the classification code F1 (assigned following the criteria of Chapter 2.2 [3]). Classification code F1 includes flammable liquids having a flash-point of or below 60C.

Column (4) "Packing group" [3]. Contains the packing group number I assigned to the dangerous substance. For packing purposes, substances of Class 3 are assigned to packing groups following the degree of danger they present. Packing group I means substances presenting high danger (assigned following the criteria of Chapter 2.1.1.3 [3]).

Column (5) "Labels" [3]. Contains the model number of the labels (assigned following the criteria of 5.2.2.2 and 5.3.1.7 [3]) that have to be affixed to packages, portable tanks, tank-wagons, and wagons. The specimen labels of Class 3 to which the Flammable Liquid, N.O.S. are given in Table 1.

**Table 1.** The specimen labels of Class 3 to which the Flammable Liquid, N.O.S.

<b>Label model No.</b>	<b>Symbol and symbol color</b>	<b>Background</b>	<b>Figure in the bottom corner (and figure color)</b>	<b>Specimen labels</b>
3	Flame: black or white	Red	3 (black or white)	

Column (6) “Special Provisions” [3]. Contains the numeric codes of special provisions that have to be met. These provisions concern a wide array of subjects, mainly connected with the contents of Columns (1) to (5) (e.g. carriage prohibitions, exemptions from requirements, explanations concerning the classification of certain forms of the dangerous goods concerned, and additional labeling or marking provisions), and are listed in Chapter 3.3 in numerical order. The Flammable liquid, N.O.S. has a numeric code of special provisions 274. This numeric code refers to the name N.O.S. and the provisions of Chapter 3.1.2.8., need to be applied.

Column (7a) “Limited quantities” [3]. Provides the maximum quantity per inner packaging for carrying dangerous goods as limited quantities following Chapter 3.4. The Flammable Liquid, N.O.S., must not be carried in limited quantities.

Column (7b) “Excepted Quantities” [3]. Dangerous goods which may be carried as excepted quantities following the provisions of Chapter 3.5 are shown in column (7b) through an alphanumeric code. Alphanumeric codes starting with the letter "E" signify that the provisions of RID are not applicable if the conditions indicated in Chapter 3.5 are fulfilled. The alphanumeric code for the Flammable Liquid, N.O.S. is given in Table 2. (following Chapter 3.5.1.2 [3]).

**Table 2.** The alphanumeric code for the Flammable Liquid, N.O.S.

<b>Code</b>	<b>Maximum net quantity per inner packaging (in ml for liquids)</b>	<b>Maximum net quantity per outer packaging (in ml for liquids)</b>
E3	30	300

Column (8) “Packing instructions” [3]. Alphanumeric codes starting with the letter “P”, which refers to packing instructions for packagings and receptacles (except IBCs and large packagings), or "R", which refers to packing instructions for light-gauge metal packagings. These are listed in Chapter 4.1.4.1 in numerical order, and specify the packagings and receptacles that are authorized. They also indicate which of the general packing provisions of Chapters 4.1.1, 4.1.2, and 4.1.3, and which of the special packing provisions of Chapters 4.1.5, 4.1.6, 4.1.7, 4.1.8, and 4.1.9 have to be met. The packing instructions P001 apply to Flammable Liquid, N.O.S.

Column (9a) “Special packing provision” [3]. Special packing provisions, indicated in Column (9a), may change the packing instructions listed in Column (8). For the Flammable Liquid, N.O.S., Column (9a) does not contain codes of the applicable special packing provisions. Therefore, for the Flammable Liquid, N.O.S., none of the special packing provisions listed at the end of the relevant packing instruction apply.

Column (9b) “Mixed packing provisions” [3]. When mixed packing is permitted following the provisions of Chapter 4.1.10, different dangerous goods or dangerous goods and other goods may be packed together in combination packagings conforming to Chapter 6.1.4.2.1, provided that they do not react dangerously with one another and that all other relevant provisions of Chapter 4.1.10 are complied with. Column (9b) contains an alphanumeric code starting with the letters "MP" of the applicable mixed packing provisions. These are listed in Chapter 4.1.10 in numerical order. When indicated for a given entry in Column (9b) for the Flammable Liquid, N.O.S, the following special provisions shall apply to the mixed packing of the good assigned to that entry with other goods in the same package: MP7 and MP 17. An alphanumeric code MP7 means: May in quantities not exceeding 5 liters per inner packaging be packed together in a combination packaging conforming to Chapter 6.1.4.21:

- with goods of the same class covered by other classification codes when mixed packing is also permitted for these; or
- with goods that are not subject to the requirements of RID provided, they do not react dangerously with one another.

An alphanumeric code MP17 means May in quantities not exceeding 0.5 liters per inner packaging and 1 liter per package be packed together in a combination packaging conforming to Chapter 6.1.4.21:

- with goods of other classes, except Class 7, when mixed packing is also permitted for these; or
- with goods that are not subject to the requirements of RID provided, they do not react dangerously with one another.

Column (10) “Portable tank and bulk container instructions” [3]. Contains an alphanumeric code assigned to a portable tank instruction, following Chapters 4.2.5.2.1 to 4.2.5.2.4 and 4.2.5.2.6. This portable tank instruction corresponds to the least stringent provisions that are acceptable for the carriage of the substance in portable tanks. The codes identifying the other portable tank instructions that are also permitted for the carriage of the substance are to be found in Chapter 4.2.5.2.5. The general requirements for the design, construction, equipment, type approval, testing, and marking of portable tanks are to be found in Chapter 6.7. The general requirements for the use (e.g. filling) are to be found in Chapters 4.2.1 to 4.2.4. Special provisions, indicated in Column (11), may change the requirements which are listed in the previous columns. Portable tank special provisions are identified by an alphanumeric code beginning with the letters “TP” (tank provision) and are assigned to specific substances. The alphanumeric code T11 is applied to the Flammable Liquid, N.O.S. Portable tank special provisions T11 are “Reserved”.

Column (11) “Portable tank and bulk container special provisions” [3]. Contains the alphanumeric codes of the portable tank special provisions that have been added to be met. These codes, starting with the letters “TP” refer to special provisions for the construction or use of these portable tanks. They are to be found in Chapter 4.2.5.3. Portable tank instruction T1 applies to the Flammable Liquid, N.O.S. Portable tank instructions T1 to T22 specify the applicable minimum test pressure, the minimum shell thickness (in mm reference steel), and the pressure-relief and bottom-opening requirements.

Column (12) “Tank codes for RID tanks” [3]. Contains an alphanumeric code describing a tank type, following Chapter 4.3.4.1.1 (for substances of Classes 3). This tank type corresponds to the least stringent tank provisions that are acceptable for the carriage of the relevant substance in RID tanks. The codes describing the other permitted tank types are to be found in Chapter 4.3.4.1.2). The four parts of the codes (tank codes) given in Column (12) have the meanings following in Table 3.

**Table 3.** The four parts of the tank codes

<b>Part</b>	<b>Description</b>	<b>Tank code</b>
1	Types of tank	L = tank for substances in the liquid state S = tank for substances in the solid-state (powdery or granular)
2	Calculation pressure	G = minimum calculation pressure according to the general requirements of Chapter 6.8.2.1.14
3	Openings	A = tank with bottom-filling with 2 closures; B = tank with bottom-filling openings with 3 closures; C = tank with top-filling and discharge openings with only cleaning openings below the surface of the liquid; D = tank with top-filling and discharge openings with no openings below the surface of the liquid.
4	Safety valves/devices	V = tank with a breather device, but no device protecting against the propagation of a flame; or non-explosion pressure shock resistant tank; F = tank with a breather device, fitted with a device protecting against the propagation of a flame; or explosion pressure shock resistant tank; N = tank without a breather device and not hermetically closed; H = hermetically closed tank.

The rationalized approach for assignment of tank codes to groups of substances and hierarchy of tanks on the example of Flammable Liquid, N.O.S. is shown in Table 4.

**Table 4.** Rationalized approach for assignment of tank codes to groups of substances and hierarchy of tanks on the example of Flammable Liquid, N.O.S

Tank code	Group of permitted substances		
	Class	Classification code	Packing group
L4BN	3	F1	I

Column (13) “Special provisions for RID tanks” [3]. For the Flammable Liquid, N.O.S. this Column does not contain an alphanumeric code of the special provisions for RID tanks that have been added to be met.

Column (14) (Reserved).

Column (15) “Transport category” [3]. Contains a figure indicating the transport category to which the substance or article is assigned to exempt transport operations performed by undertakings in connection with their main business (Chapter 1.1.3.1 (c)).

Column (16) “Special provisions for carriage – Packages” [3]. Not applicable for the Flammable Liquid, N.O.S. (following Chapter 7.2.4).

Column (17) “Special provisions for carriage – Bulk” [3]. Not applicable for the Flammable Liquid, N.O.S. (following Chapters 7.1 and 7.3).

Column (18) “Special provisions for carriage – Loading, unloading and handling” [3]. Special provisions for carriage – Loading, unloading, and handling does not apply to the Flammable Liquid, N.O.S. (following Chapter 7.5.1.1). Only general provisions apply.

Column (19) “Colis express (express parcels)” [3]. Carriage of the Flammable Liquid, N.O.S. as express parcels, is not allowed (following Chapter 7.6).

Column (20) “Hazard identification number” [3]. Contains a two or three-figure number for substances of Class 3. The meaning of the hazard identification numbers is explained in Chapter 5.3.2.3. The hazard identification number 33 listed in Column (20) has the following meaning: Highly flammable liquid (flash-point below 23 °C).

## CONCLUSION

The flammable liquid, which is analyzed in this paper, is a dangerous commodity in RID transport, the name of which is “not otherwise specified”. The official name (shipping names) of the dangerous substance in RID carriage is Flammable Liquid, N.O.S. For the dangerous good of UN number 1993, the name of which is "not otherwise specified", RID defines the general transport conditions following the corresponding class of danger in the carriage.

By interpreting the data from Table A, the special RID carriage conditions of the Flammable Liquid, N.O.S. are determined, which are valid under the general conditions (if they are prescribed). By crossing the identified general and special conditions, in the end, the comprehensive RID carriage conditions are determined. The Flammable Liquid, N.O.S. is the only permitted condition under which the substance can be transported in railway traffic.

RID transport conditions of Flammable Liquid N.O.S., in the first 5 columns of Table A include data on the class of dangerous goods, on the classification code, on the group of packing, labels. These data are derived from the physical and chemical properties of this dangerous good. Columns (6), (7a), (7b) specify special provisions for limited and exempted quantities. Columns (8), (9a), (9b) define the packing provisions. Columns (12), (13) are very important because they define special provisions for RID tanks (type and codes). Columns (16), (17), (18) do not prescribe the special provisions for carriage (bulk, packages, loading, unloading, and handling). Column (20) shows data on the Hazard identification number. The Flammable Liquid, N.O.S. is a highly flammable liquid (flash-point below 23°C) and following Class 3 to which it belongs, it has a very high degree of danger in the carriage.

According to the obtained results it can be considered that the degree of danger, which is represented by the Flammable Liquid N.O.S. in RID carriage, depends primarily on its physical and chemical properties, and the fulfillment of carriage conditions in tanks and tank wagons.



If the rail carriage of the Flammable Liquid, N.O.S. is performed according to the permitted RID conditions, it can significantly reduce the risk of carriage incidents and chemical accidents. The further workflow could include linking the permitted RID carriage conditions of Flammable Liquid, N.O.S. with the ADR conditions of its ADR carriage, etc.

## REFERENCES

- [1] Law on Transport of Dangerous Goods, "Official Gazette of RS", No. 104/2016, 83/2018, 95/2018, 10/2019
- [2] ECE/TRANS/3300, Agreement Concerning the International Carriage of Dangerous Goods by Road (ADR), Economic Commission for Europe Inland Transport Committee, UN, 2020.
- [3] Convention Concerning International Carriage by Rail (COTIF), Appendix C – Regulations Concerning the International Carriage of Dangerous Goods by Rail (RID), Intergovernmental Organisation for International Carriage by Rail-OTIF and UNECE, 2020. Available at: <https://otif.org/en/>
- [4] Rulebook on technical and other requirements for materials and goods according to fire behavior, "Official Gazette of RS", No. 74/2009
- [5] Production and use of flammable liquids, Brochure, Center for Sustainable Development-CORE, Novi Sad, 2007.  
Available at: <https://www.core-ns.org/zastita-od-pozara-permanentna-edukacija.html>
- [6] Arandelović, I., Rajić, R., Savanović, M., Đinović, I.: Fire hazard classes of industrial facilities, Proceedings wrote for 32<sup>nd</sup> International Congress on Process Industry, pp. 333-337, Sava Centar, Belgrade, 2019.
- [7] Regulation (EC) No 1272/2008 of the European Parliament and of the Council of 16 December 2008 on Classification, Labelling, and Packaging of substances and mixtures. Available at: <https://echa.europa.eu/hr/regulations/clp/legislation>

## MICROPLASTICS AND IMPLICATION ON HEALTH BY USING FACE MASKS DURING THE COVID – 19 PANDEMIC

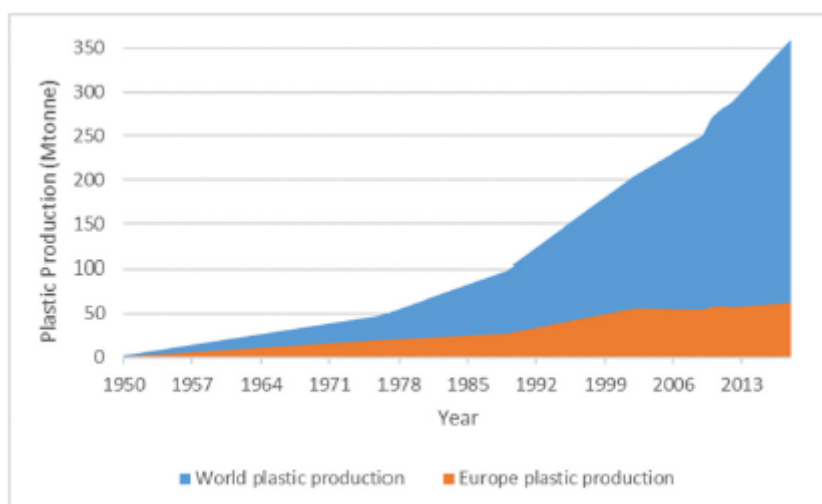
Snežana Filip, Bogdana Vujić, Una Marčeta, Eleonora Terečik  
University of Novi Sad, Technical Faculty “Mihajlo Pupin”, Zrenjanin, Serbia  
e-mail: [zana@tfzr.uns.ac.rs](mailto:zana@tfzr.uns.ac.rs)

**Abstract:** The paper represents a short review of microplastics production in the world, and the more and more presents of microplastics in the air. The distribution and behavior of microplastics suspended in the air is like those of other airborne pollutants. Particular emphasis is placed on the impact of microplastics from the face masks on human health, during COVID-19 pandemic.

**Key words:** microplastics, human health, face masks.

### INTRODUCTION

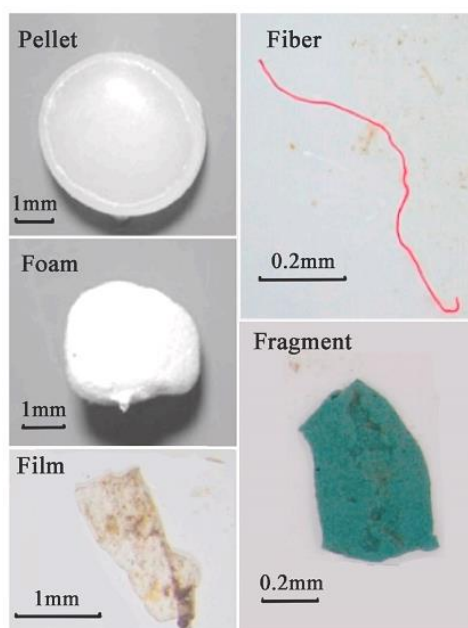
Global plastic production increased from 1.7 to 370 million tones annually within the last 70 years (Fig. 1) [1], where in Europe, plastic production reached almost 58 million tones annually (Plastics Europe, Association of Plastic Manufacturers) [2]. With an exponential increase in the production and consumption of this material ever since the 1950s, plastics have become an integral part of modern society. The global average use of plastics is 45 kg per person per year. Western Europe (Europe excluding central Europe and the Commonwealth of Independent States) uses three times as much — around 136 kg per person [3]. The three largest end-use plastic markets are: (a) packaging, (b) building and construction, and (c) the automotive industry, accounting for almost 70 % of all plastics used in Europe. Such a large production and consumption of plastic material generates a large amount of plastic waste. Plastics end up everywhere in the environment: in air, soil, freshwater, seas, and some components of our food. Plastics of various sizes are released into the environment, from large plastic articles such as plastic bags and bottles, to smaller particles found in textiles and cosmetics. Larger plastic items in the environment may fragment and degrade into micro-plastics.



**Fig. 1.** Plastic production's growing from 1950 to 2018 (data adapted from Plastics Europe, Association of Plastic Manufacturers: Brussels) [2].

The term “microplastic” was firstly coined in 2004 to describe small plastic particles (from millimetre to sub-millimetre sized particles), but the use of this term is from 2008 when The National Oceanic and Atmospheric Administration (NOAA) were defined it as plastic particles smaller than 5 mm. So, the plastics particles smaller than 5 mm are called micro-plastics (5 mm – 1 µm), and plastics smaller

than 1  $\mu\text{m}$  are called nano-plastics [1]. Microplastics can be classified using different approaches. Based on their sources, they can be divided into primary and secondary microplastics. Primary microplastics refer to the direct use of plastic microbeads in specific cosmetics and fiber fragments resulting from in-used wear or washing the textiles that have been directly released into the environment [4]. Secondary microplastics are plastic fragments formed by larger plastic waste by degradation processes that cause fragmentation and volume reduction. The secondary microplastics from plastic degradation, come from biodegradation, physical degradation, photo-degradation and chemical degradation [5]. The morphology of microplastics can be divided into plastic pellets, plastic granules, micro-fibers, foam plastics, films and other materials (Fig. 2). Another typical classification method for microplastics is based on its chemical components, such as polyethylene (PE), polypropylene (PP), polyvinyl chloride (PVC), polystyrene (PS), polyurethane (PUR) and polyethylene terephthalate (PET). Microplastics are globally spread throughout the environment, and their negative impact is enhanced by their ability to adsorb organic pollutants and heavy metals (Wang et al., 2021)



**Fig. 2.** Morphologies of different microplastics [6]

In the recent research microplastics are well suited to serve as vectors for many organic pollutants. Polychlorinated biphenyls (PCBs), polycyclic aromatic hydrocarbons (PAH), and polybrominated diphenyl ethers have been frequently observed in plastic waste gathered from seawater and shoreline sediments [7]. Moreover, because of long time degradation process, microplastics can disrupting the equilibrium of the ecosystem and adversely affecting human health, unfortunately enter in the food chain. The potential hazards of microplastics to organisms include the inflammation of the digestive system, reduced nutrient absorption, and influences on growth and reproduction [4].

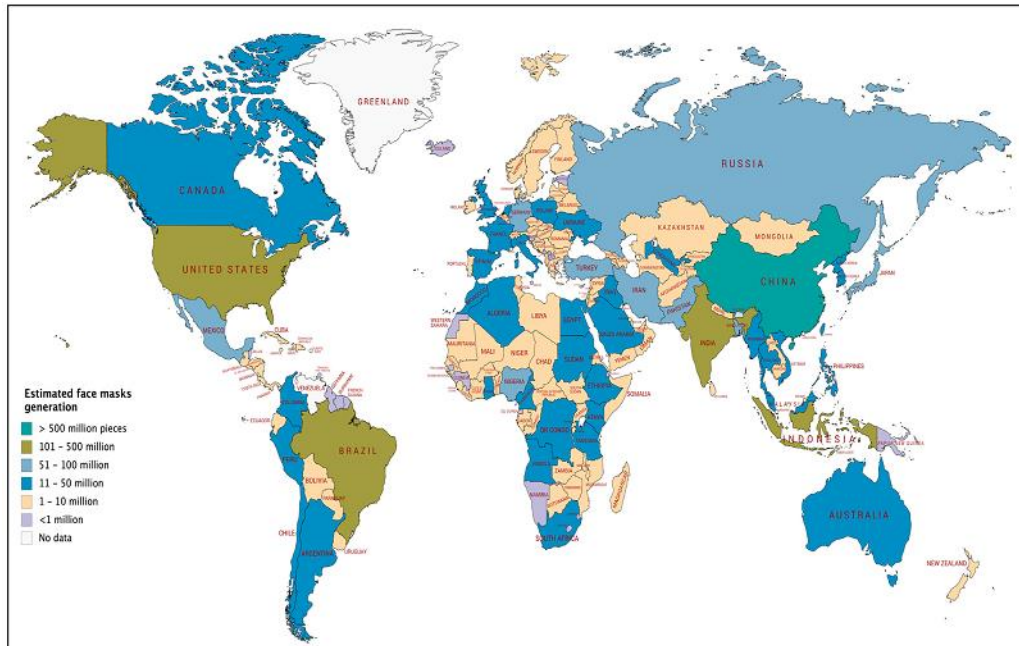
Microplastic pollutions in aquatic environments has attracted the scientific interest, with the majority of research on microplastic in surface waters, in soils and sediments. During the last decade, great attention has been paid to the presence of microplastics in the air. In the last two years, we have used a huge plastic products and face masks during the COVID-19 pandemic. Therefore, the risk due to inhalation of microplastic released by the face masks is discuss in this paper.

## DISCUSSION

The emergence of a new coronavirus (SARS-CoV-2) has led to a global political, economic, environmental, and sanitary crisis. From the, World Health Organisation (WHO), US Centers for Disease Control and Prevention, European Center for Disease Prevention and Control, governments of all states have recommended several measures: first of all using personal protection equipment's,

frequent hand washing, cancellation of mass gatherings, social distancing, travel restrictions, and the most rigorous measure lockdowns. Almost all countries have recommended and implemented the use of face masks to reduce the level of human-to-human transmission, and protect the most vulnerable populations. Therefore, in line with this recommendation, millions of face masks have been produced, used and discarded daily (Fig. 3) [8]. Considering that we have 7.8 billion inhabitants on the globe, use of masks worldwide leads to a monthly consumption of approximately 129 billion masks. Even though, data from June 2020 shown that China produced 200 million face masks a day, which is twenty times the amount they made at the start of February 2020 [9].

Different kinds of masks are being used: surgical, KN95, FFP2, FFP3, cotton, fashion, or activated carbon masks are some of the most popular. Yet, surgical masks are the most used. These masks should be worn for a few hours (e.g., 4 h) and adequately throw away.



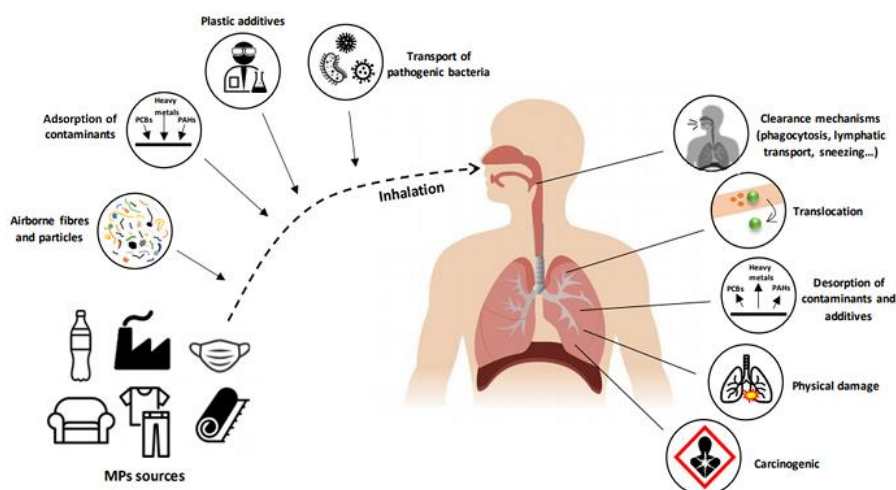
**Fig. 3.** Estimated global share of face masks discarded as COVID-waste [8]

From the paper of Fadare and Okoffo (2020) [10] about 10 million masks are being introduced in the environment monthly which is near to 30–40,000 kg of plastic. So, we can say that the COVID-19 pandemic has created more biomedical waste in the form of waste plastics. In China where the COVID-19 was first reported, the Emergency Management Office of the Ministry of Ecology and Environment documented a 23% increase in the amount of medical waste generated and treated [8]. In Serbia the medical waste in 2019 was 3,282 tones [11], so we can not compare with the generating medical waste in 2020, for which there is no data.

Such an enormous generation of face masks which are discarded into the environment, and are not managed properly, could be degraded into smaller sized particles- microplastics which exacerbate the problem of environmental pollution. From the previous discussion, it can be obvious the impact of face masks on the environment, but it would be interesting to evaluate their impact on human health.

From the WHO and Ministry of Health recommended N95 and KN95 and surgical masks, that are designed for maximum filtration of aerosols and infectious airborne particles, to protect the user from respiratory diseases including COVID-19. The problem for health is when it is repeatedly used. Wearing and inhalation risks of microplastics fibre increased with improper use of masks, although all masks reduce the inhalation risks of microplastics particles (except when using disinfection pre-treatments). Also, the using poor – quality masks may represent higher microplastics inhalation risk, compared with quality masks. Also, microplastics from face masks may be accumulated in the nasal cavity (Fig. 4). Research done by Li and others (2021) [12] tested a wide range of mask products and found that all types would increase the daily intake of microplastic fiber during wear, except for N95.

Activated carbon masks produced the most micro-fibers, followed by surgical, cotton, fashion and N95 masks. In this study, N95 mask is proved to the best in filtration of airborne particles. Recent study done by Fernandez-Arribas and colleagues (2021) [13] examined the organophosphate ester content in different types of face masks used for coronavirus prevention. Organophosphate esters are widely used as plasticizers and flame retardants. The highest levels of organophosphate esters were found in KN95 masks (mean value of 11.6  $\mu\text{g}/\text{mask}$ ), while the lowest values were those of surgical masks (mean value of 237  $\text{ng}/\text{mask}$ ). Analytical tests done at the Hamburg Environmental Institute on used surgical masks, shown traces of chemicals such as the known carcinogen aniline as well as formaldehyde and optical brighteners. From the testing by Modern Testing Services Augsburg, Germany was found elevated concentrations of hazardous fluorocarbons, formaldehyde and acetaldehyde.



**Fig. 4.** Implications of microplastics inhalation and possible consequences in human respiratory system [1]

The laboratory testing have also shown the presence of compounds such as 2-butanone oxime (carcinogenic) blocked diisocyanates used as crosslinkers for perfluorocarbons (PFCs) on face masks. These substances are used as oil and water repellents on fabrics, in textile industry. By-products of PFCs are known to be bio-persistent and their use is heavily restricted in Europe and the USA. Last year, a group of US scientists called for all per- and poly-fluorinated substances (PFAS) as one single class of chemistry and said they should be avoided for non-essential uses due to their hazardous toxicological and eco-toxicological profile [14]. PFCs have task to repel the virus in an aerosol droplet format – but PFC on face, nose, on the mucus membranes, or on the eyes is not good. From the above, we can conclude that face mask wear potentially hazardous chemicals and harmful microplastics which being inhaled deep into human lungs.

It can be noted that surgical masks have been designed to be worn for very specific purposes such as by clinicians or for a short period of time before being discarded. During one year of experience face masks are crumpled up in people's pockets where the friction and damp environment promotes both fiber abrasion and the appearance of bacteria over time. This abrasion can, cause the release of tiny microplastics as the polypropylene fibres break down from mechanical wear and tear, finding in tests that some masks shed microfibrils classed as hazardous "dust". Fibers of this type of geometry that meet this dust standard are also referred to as "WHO fibres".

## CONCLUSION

In the conclusion, we can say that microplastics are potential contaminants of emerging concern due to their widespread occurrences on Earth, from the soil to water and atmosphere. Face masks have become indispensable in society, so future research should investigate health risks related to short and long-term inhalation of microplastics. Wearing a face masks become a way of life during the coronavirus pandemic, but it can also cause us a health problems, by inhale harmful microplastic. The

exact health side effects caused by spherical- and fiber-like microplastic is unclear, so it would be interesting to make further research in this field for better understanding impact on human health. Mask wearers unwittingly run the risk of breathing in carcinogens, allergens and tiny synthetic microfibres by wearing both textile and nonwoven surgical masks for long periods of time. Leading scientists are now questioning whether the real risk of exposure to potentially hazardous chemicals from long-term mask wearing is actually higher than the risk of coming into contact with the Sars-CoV-2 virus – especially for children and young adults who are in the low-risk category when it comes to developing severe COVID-19 [14].

## REFERENCES

- [1] Torres-Agullo A., Karanasiou A., Moreno T., Lacorte S. Overview on the occurrence of microplastics in air and implications from the use of face masks during the COVID-19 pandemic. *Science of the Total Environment* 800, 149555, 2021.
- [2] Plastics Europe, 2020. *Plastics - The Facts 2020, an Analysis of European Latest Plastics Production, Demand and Waste Data*. <https://www.plasticseurope.org/en/resources/publications/4312-plastics-facts-2020>. accessed 30.08.2021
- [3] Plastics Insight, 2016, 'Global consumption of plastic materials by region (1980-2015)', Market statistics (<https://www.plasticsinsight.com/global-consumption-plastic-materials-region-1980-2015/>) accessed 30.08.2021
- [4] Yang S., Zhou M., Chen X., Hu L., Xu Y., Fu W., Li C. A comparative review of microplastics in lake systems from different countries and regions. *Chemosphere* 286, 131806, 2022.
- [5] Klein S., Dimzon I.K., Eubeler J., Knepper T.P. Analysis, Occurrence, and Degradation of Microplastics in the Aqueous Environment. *Freshwater MicroPlast* pp. 51–67, 2018.
- [6] Wu C., Zhang K., Xiong X. Microplastic Pollution in Inland Waters Focusing on Asia. *Freshwater Microplast.*, pp. 85–99, 2018.
- [7] Mai L., Bao L.-J., Shi L., Liu L.-Y., Zeng E.Y. Polycyclic aromatic hydrocarbons affiliated with microplastics in surface waters of Bohai and Huanghai Seas, China. *Environ. Pollut.* 241, 834–840, 2018
- [8] Benson N.U., Bassey D.E., Palanisami T. COVID pollution: impact of COVID-19 pandemic on global plastic waste footprint. *Heliyon* 7, e06343, 2021.
- [9] Aragaw T.A., Surgical face masks as a potential source for microplastic pollution in the COVID-19 scenario. *Mar. Pollut. Bull.* 159, 111517, 2020
- [10] Fadare O.O., Okoffo E.D. Covid-19 facemasks: a potential source of microplastic fibers in the environment. *Sci. Total Environ.* 737, 140279, 2020.
- [11] [www.sepa.gov.rs](http://www.sepa.gov.rs) (accessed 06.09.2021)
- [12] Li L., Zhao X., Li Z., Song K. COVID-19: Performance study of microplastic inhalation risk posed by wearing masks. *J.Hazard. Mater.* 411, 124955, 2021
- [13] Fernandez-Arribas J., Moreno T., Bartroli R., Eljarrat E. COVID-19 face masks: A new source of human and environmental exposure to organophosphate esters. *Environment International* 154, 106654, 2021.
- [14] [www.ecotextile.com](http://www.ecotextile.com) (accessed 06.09.2021)

## IDENTIFYING METHOD OF MANAGING MEDICAL WASTE DURING THE PANDEMIC OF COVID-19

Eleonora Terečik<sup>1</sup>, Višnja Mihajlović<sup>1</sup>, Una Marčeta<sup>1</sup>, Marko Jovanov<sup>1</sup>

<sup>1</sup>University of Novi Sad, Technical Faculty "Mihajlo Pupin", Zrenjanin, Serbia

e-mail: [elaterecik5@gmail.com](mailto:elaterecik5@gmail.com)

**Abstract:** Nowadays, the biggest challenge is the way of disposing of all types of waste, including medical, but to do it safe, efficient and without endangering the environment. Every institution, even a person, is a producer of some kind of waste. The aim of this research is to review the current medical waste management situation during the COVID-19 pandemic. Based on the insight into the existing capacities that can be engaged for the treatment of hazardous medical and pharmaceutical waste, as well as the estimated quantities and types of waste generated during the treatment and care of COVID-19 virus, in the private sector about 150 tons per month, it can be concluded that there are conditions for safe management of the subject hazardous waste in emergency situations.

**Key words:** medical waste, pandemic COVID-19, medical waste management, environment.

### INTRODUCTION

On January 12, 2020, the World Health Organization confirmed that cause of a respiratory infection in a group of patients in Wuhan, a city in the Chinese province of Hubei, was a new coronavirus (later called Covid-19), whose global spread was declared a global pandemic on March 11. At the end of February 2020, testing for COVID-19 began in the Republic of Serbia, and at the beginning of March, the first case of infection was recorded. The pathogen that causes severe acute respiratory syndrome - coronavirus - is referred to as SARS-Cov-2. However, a negative impact was observed as well as in the waste management sector. The fight to reduce the use of disposable plastic was further complicated by a new source of pollution - disposable medical protective equipment (masks, gloves, spacesuits, bedding from COVID hospitals) which ends up in rivers and oceans due to improper disposal. Given the increased number of infected and sick, as well as the forecasts of epidemiologists, it is necessary to consider waste streams that will occur during pandemic, as well as capacities and treatment options so as not to endanger the health of people employed in health care facilities and temporary accommodation facilities for the reception of patients with a milder clinical picture, but also endangering the environment. Medical waste is a heterogeneous mixture of municipal waste, infectious, pathoanatomical, pharmaceutical and laboratory waste, disinfectants and packaging, as well as radioactive and hazardous chemical waste. It is a waste that consists entirely or partially of human or animal tissues, blood and other body fluids, secretions, drugs and other pharmaceuticals, swabs, gauze, bandages, needles, scalpels, sharp instruments [1]. About 70% to 90 % of medical waste is municipal waste. Of this, 10% to 30% can be classified as hazardous waste that may pose a risk to health and the environment. Medical waste generated in health care institutions must be treated in accordance with the provisions of the Law on Waste Management and in accordance with the Ordinance on Medical Waste Management and the Ordinance on Pharmaceutical Waste Management. In accordance with the provisions of the Law on Waste Management, the waste producer is obliged to hand over the waste to the operator who has a permit issued by the competent authority for the treatment of this type of waste. All waste generated by patients with coronavirus is infectious medical waste and as such must be treated before disposal (sterilized and ground) [2]. Infectious medical waste, together with sharp objects, belongs to index numbers 18 01 01/18 01 03 \* and includes all waste contaminated with blood, waste from infusion, diagnostics, treatment of patients (syringes, needles, gauze, bandages ...) [3,5].

## **MATERIAL AND METHODS**

### **Waste quantities and waste streams**

Solid waste: protective equipment, care and treatment products, drug waste and contact packaging for drugs and disinfectants (pharmaceutical waste) and the like, in quantities up to 1.5 kg / bed / day. Disposable contaminated bedding is not included.

Liquid and semi-liquid waste: chemical waste from the laboratory, food waste, excreta and secretions, urinary bags, etc. in the amount of up to 0.5 kg / bad / day.

Waste from testing: testing for COVID-19 is performed by taking a swab, usually from the throat, or by taking blood for serological analysis. Waste generated after testing is index number 18 01 03 \* and belongs to waste contaminated with blood and body fluids.

In a state of emergency, it is difficult to accurately determine the amount of waste generated, due to the fact that the amount of contaminated objects / items is constantly increasing, etc. (masks, gloves, suits, bedding, dining utensils, food scraps...) [3, 4].

### **Waste collection and transport**

The private operator, which has about 4,500 customers on a monthly basis, collects waste every day. Waste vehicles must be additionally disinfected with hypochlorite, hydrogen peroxide or alcohol. Personnel which are handling waste must have a disposable protection kit. Transport routes must be clearly defined and defined in advance. Medical waste vehicles are used exclusively for this purpose. They must not be used for other purposes while the risk of infection with the virus persists. The use of protective equipment has increased, masks with separate filters, visors, special suits and gloves are used. Vehicles are disinfected three times a day, work areas, plants and the circuit at least twice a day. Upon entering the waste management circle, the waste is first disinfected, together with the primary and secondary packaging, and only after that is the manipulation and treatment started.

## **WASTE TREATMENTS**

In the private sector, the private operator does not store the waste, but treats it immediately. Infectious medical waste generated by patients with COVID-19 is sterilized in autoclaves by at 1.4 bar at 136 °C, after which it must be crushed (classic fine-grained shredding) before disposal at the landfill. Waste sterilization can be dry, wet, chemical, UV and combined. The confirmed and most efficient method is steam sterilization and high pressure. The rest is something a little bigger than the powder, what is left when the whole processing process is finished, non-hazardous sterilized waste. It ends up in green containers.

Incineration is also a possible way of treating such waste, and this technique involves incineration of waste at a certain temperature and under controlled conditions in plants for which there is an appropriate permit. A private company that owns an incinerator for infectious waste has two incineration chambers. The first burns at 815°C and the second at 1100°C. The remains after incineration are ash, which also ends up in the landfill. Pathoanatomical waste is mostly burned [6].

## **MEDICAL WASTE STORAGE PACKAGING**

Private operators, as part of the waste treatment service, provide their customers packaging/storage packaging for waste disposal. Plastic packaging 1L volumes is given to dental practices, 3L and 5L are given to clinics and smaller hospitals and 20L for clinical centers. Infectious waste is packed in yellow bags and / or yellow containers. In the institutions where are infectious patients, with COVID-19, it is necessary to strengthen the packaging or double the bags in order to prevent waste spillage.

Chemical and pharmaceutical waste is mostly exported for treatment in incinerators. In case of current impossibility to export hazardous waste, pharmaceutical and chemical waste must be temporarily stored, in accordance with appropriate regulations, at the place where the waste is generated or it can be handed over to authorized operators who will store it at their location until the moment of export.



This type of waste is collected in red bags or containers. While cytotoxic waste is collected in purple bags or containers. Waste from disposable clothing and personal protective equipment (gloves, masks, nipples) will also be significantly represented. Due to possible environmental contamination, this waste belongs to the medical waste of index number 18 01 03 \* and is treated in waste incineration plants or in autoclaves with crushers. This waste is packed in yellow bags and / or yellow containers. Food waste is mixed organic waste that must not be given to animals or disposed of uncontrolled in landfills. This type of waste does not require special packaging. Pathoanatomical waste treated in incinerators is packed in brown bags [7, 8].

## **RESULTS AND DISCUSSION**

Private operator in Serbia, which treats medical waste in autoclaves, has a capacity of 130 kg / h and 160 kg / h. It also treats medical waste by incineration and has a capacity of 160 kg / h, and in accordance with the temporary permit issued by the competent authority, it treats medical and pharmaceutical waste. All waste is disposed of, and about 150 tons of medical waste arrives per month. The existing capacities are sufficient and it is estimated that they are about two to three times larger than the generated medical waste, and even with the appearance of a pandemic, they can easily cover the increase in waste production.

## **CONCLUSION**

In the current situation of the COVID-19 pandemic, the importance of proper and accurately waste management becomes even more important, as the amount of medical waste, including from households (such as protective masks and gloves) is mixed and disposed together with household waste, significantly increasing waste quantities. Waste from health care institutions where COVID-19 virus is treated, must not be brought into other health care facilities. The existing facilities, according to estimates, meet the needs for the treatment of hazardous medical waste. What should be done to safely collect it, and treat such waste is for local governments to engage in finding a place to collect where citizens would have the option to bring and hand over the used masks and gloves, and then to hire specialized companies to collect and treat the same. Simply, influence and give responsible citizens the opportunity to have a place to postpone protective gear, and in this way contribute to preventing the spread of the pandemic. The same applies to the industry. Each responsible company should provide a place to dispose of used protective equipment, and as such hand it over for safe treatment.

## **REFERENCES**

- [1] Ordinance on the Management of Medical Waste (Official Gazette of the Republic of Serbia, No. 48/2019)
- [2] Tanaskovic, M.: Medical waste, City Institute for Health Protection, Belgrade, 2007.
- [3] Ministry of Environmental Protection.
- [4] Directorate for Biomedicine - Ministry of Health of the Republic of Serbia.
- [5] <http://www.sepa.gov.rs> (accessed 15.08.2021)
- [6] Ugrinov D, Stojanov A: Legislative framework and competencies in the field of medical waste management, 2013.
- [7] Todic, D., Iskovski, Z., Katic, M.: Hazardous Waste Management in the Republic of Serbia, Belgrade, 2013.
- [8] Borovina, B.: Reverse logistics in healthcare - Medical waste management, 6th Scientific Conference with International Participation Synergy, 2010.

## POLLUTANT EMISSIONS FROM FOSSIL FUEL COMBUSTION USED FOR HEATING OF DETACHED RESIDENTIAL BUILDINGS

Amelija Đorđević<sup>1</sup>, Ana Vukadinović<sup>1</sup>, Jasmina Radosavljević<sup>1</sup>, Bogdana Vujić<sup>2</sup>

<sup>1</sup>Faculty of Occupational Safety, University of Niš, Republic of Serbia

<sup>2</sup>Faculty of Technical Sciences – Mihajlo Pupin, University of Novi Sad, Republic of Serbia

[amelija.djordjevic@znrfak.ni.ac.rs](mailto:amelija.djordjevic@znrfak.ni.ac.rs), [jasmina.radosavljevic@znrfak.ni.ac.rs](mailto:jasmina.radosavljevic@znrfak.ni.ac.rs),

[ana.vukadinovic@znrfak.ni.ac.rs](mailto:ana.vukadinovic@znrfak.ni.ac.rs), [bogdana.vujic@tfzr.rs](mailto:bogdana.vujic@tfzr.rs)

**Abstract:** The research presented in this paper is motivated by the fact that air quality monitoring in Serbia has indicated the presence of high concentrations of PM<sub>10</sub>, PM<sub>2.5</sub>, and other pollutants in outdoor ambient air, which are caused by the use of fossil fuels as energy-generating products. The research focuses on the cause-and-effect relationship between air pollution and the use of fossil fuels to heat detached residential buildings on the one hand and the cause-and-effect relationship between fuel consumption and structural and architectural elements on the other hand. Comparison of the analyzed models of detached residential buildings shows that structural and architectural characteristics can help reduce suspended particle emissions by more than 70%, as well as reduce emissions of other pollutants, including carbon monoxide, carbon dioxide, sulfur oxides, nitrogen oxides, heavy metals, and volatile hydrocarbons.

**Key words:** fossil fuels, pollutants, detached residential buildings, sunspace, emission factor, pollutant emission

### INTRODUCTION

The measured ambient air pollutant concentrations, which are regularly monitored in urban areas in Serbia, vary, especially across the seasons, which may be linked to the activities of energy-producing facilities (district heating plants, industrial plants, and household heating systems) [1]. Energy facilities mostly use fossil fuels to transform the fuels' energy into heat and/or electricity [1]. The most commonly used fossil fuel worldwide as well as in Serbia is lignite. Products of lignite combustion emit NO<sub>x</sub> (of the total emitted NO<sub>x</sub>, NO constitutes about 90%), SO<sub>x</sub>, CO, non-standard pollutants CO<sub>2</sub> and N<sub>2</sub>O (emitted at temperatures over 800°C), CH<sub>4</sub> (emitted from incomplete combustion), particulate matter of the diameter smaller than 10 μm (occurring in short-lived emissions), and 189 microelements belonging to the four hazardous pollutant classes according to Baig [1]. Lignite combustion also emits low concentrations of organic compounds such as alkanes, alkenes, aldehydes, alcohols, and substituted benzoyl (benzene, toluene, xylene).

Owing to insufficiently developed gas distribution and district heating in Serbia, wood biomass is heavily used to heat detached residential buildings. According to previous research, wood biomass combustion emits large amounts of particles with a diameter from 1 to over 10 μm (PM<sub>1</sub>, PM<sub>2.5</sub>, and PM<sub>10</sub>), soot, nitrogen oxides, carbon monoxide, and polycyclic aromatic hydrocarbons (PAHs) [1].

Use of fuel oil in heat production causes emissions of particles smaller than 1 μm in diameter, but particles over 10 μm may also be emitted. The chemical composition of emitted particles is mainly inorganic and dependent on the composition complexity of the fuel itself. Fuel oil combustion emits sulfur oxides, whose concentration depends on the percentage of elemental sulfur in the fuel, nitrogen oxides, and carbon monoxide. A reduction in the efficiency of fuel oil combustion in boiler facilities will cause increased concentrations of volatile organic compounds (VOC).

Since the second half of the 20<sup>th</sup> century, natural gas has been increasingly used as an energy-generating product. Natural gas combustion results in emissions of the following compounds: NO<sub>x</sub>, CO, CO<sub>2</sub>, CH<sub>4</sub>, N<sub>2</sub>O, VOC, and small concentrations of SO<sub>2</sub> and particles [1].

### MATERIALS AND METHODS

In order to monitor pollutant emission from fossil fuel combustion used for heating of a residential building with a sunspace, we developed models to calculate the mass of pollutants emitted into the air. Modeling of pollutant emissions from fossil fuels is based on the determination of emissions from the combustion of a unit quantity (mass or volume) of fossil fuel (emission factor). Emission of all pollutants in the air is assessed based on the emission factor and activity rate for each emission source.

The total pollutant emission from fossil fuel combustion is expressed as a product emission factors and the total energy required for heating depending on the fuel type [2].

$$E_i = \sum_g (EF_i \cdot Q_g), \quad (1)$$

where:  $E_i$  – total emission of  $i^{\text{th}}$  pollutant [g],  $EF_i$  – emission factor of the  $i^{\text{th}}$  pollutant [g/GJ], and  $Q_g$  – required primary energy for heating of a detached building with a sunspace [GJ].

The following fuels were considered in the modeling of pollutant emissions: natural gas, wood biomass, pellets, fuel oil, and coal (lignite, brown coal).

The analysis of pollutant emissions for the said fuels encompasses the fuels most frequently used for residential heating in Serbia. The following pollutants emitted from fuel combustion are considered: carbon dioxide (CO<sub>2</sub>), carbon monoxide (CO), methane (CH<sub>4</sub>), nitrogen oxides (NO<sub>x</sub>), nitrous oxide (N<sub>2</sub>O), sulfur oxides (SO<sub>x</sub>), non-methane volatile organic compounds (NMVOC), cadmium (Cd), lead (Pb), total suspended particles (TSP), particles smaller than 10 μm (PM<sub>10</sub>), and particles smaller than 2.5 μm (PM<sub>2.5</sub>).

The emission factors of pollutants emitted from the combustion of specific fossil fuels are obtained from the Serbian Environmental Protection Agency's database. Table 1 provides the emission factors of pollutants depending on fossil fuel type in relation to the unit of energy required for the heating of a detached residential building. The presented emission factors are expressed in g/GJ but have been converted to g/kWh for calculation purposes.

**Table 1.** Pollutants emitted from combustion of specific fossil fuels and their emission factors [2]

Pollutant (P)	Emission factor (EF)						
	Natural gas	Wood biomass	Pellets	Fuel oil in furnaces	Fuel oil in boilers	Coal in furnaces	Coal in boilers
	[g/GJ]	[g/GJ]	[g/GJ]	[g/GJ]	[g/GJ]	[g/GJ]	[g/GJ]
CO <sub>2</sub>	5.61E+04	1.12E+05	1.12E+05	7.74E+04	7.74E+04	1.01E+05	1.01E+05
CO	3.00E+01	4.00E+03	5.00E+02	1.00E+02	4.00E+01	2.00E+03	4.00E+03
CH <sub>4</sub>	5.00E+00	3.00E+02	3.00E+02	3.00E+00	3.00E+00	3.00E+02	3.00E+02
NO <sub>x</sub>	7.00E+01	1.20E+02	9.00E+01	5.00E+01	7.00E+01	1.50E+02	1.30E+02
N <sub>2</sub> O	1.00E-01	4.00E+00	4.00E+00	6.00E-01	6.00E-01	1.50E+00	1.50E+00
SO <sub>x</sub>	5.00E-01	3.00E+01	2.00E+01	1.40E+02	1.40E+02	4.50E+02	9.00E+02
NMVOC	1.00E+01	4.00E+02	2.00E+01	2.00E+01	1.50E+01	3.00E+02	3.00E+02
Cd	5.15E-04	2.00E-03	5.00E-04	3.00E-04	2.00E-03	1.00E-03	3.00E-03
Pb	9.84E-04	4.00E-02	2.00E-02	5.00E-03	2.00E-02	1.00E-01	6.00E-03
TSP	5.00E-01	5.00E+02	8.00E+01	1.50E+01	5.00E+00	2.50E+02	4.00E+02
PM <sub>10</sub>	5.00E-01	4.75E+02	7.60E+01	1.00E+01	3.00E+00	2.40E+02	3.80E+02
PM <sub>2.5</sub>	5.00E-01	4.75E+02	7.60E+01	1.00E+01	3.00E+00	2.20E+02	3.60E+02

In order to analyze the microclimatic conditions of indoor space and the occupational or living thermal environment, models and standards for thermal comfort have been developed. This study utilizes the EnergyPlus™ model for energy analysis and heat load simulation of a building, composed of several program modules constituting a unity, which are able to calculate the energy required for building heating using different heating systems or different energy sources [3].

The structural and architectural elements of detached residential buildings are considered as models with G+1 levels, with the base aspect ratio of 2.25:1 and with a 1.2 m wide sunspace installed over the entire length of the south-facing façade. The building base dimensions are 14.4 m in length and 6.4 m in width. The base surface area is 184.32 m<sup>2</sup>, the sunspace base surface area is 34.56 m<sup>2</sup>, floor height is 3 m, the heated volume of the building is 552.96 m<sup>3</sup>, the surface area of the building's thermal envelope is 433.32 m<sup>2</sup>, and the building shape factor is 0.78.

The sunspace is modeled as a separate thermal zone. Its space is not heated or mechanically cooled, only naturally ventilated. Indoor space has a defined heating system with a design temperature of

20°C. The natural ventilation system is defined so as to provide a specific number of air changes per 24 hours.

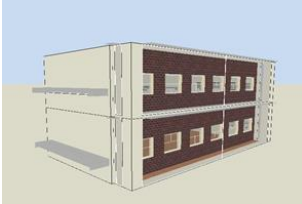
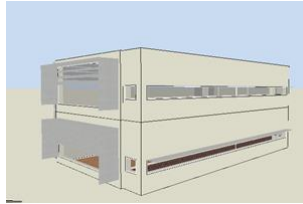
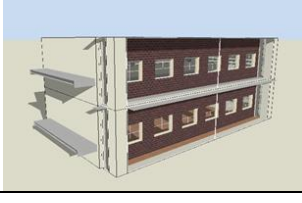
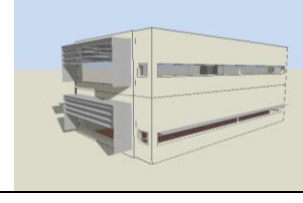
The structural and architectural elements of detached residential buildings are considered in the form of models **Op1** and **Op2** in a scenario involving the optimization of variable building parameters in order to meet the minimum heating energy requirements for a building with a sunspace.

Table 2 shows the parameters of the basic building model, which are used in the simulation of energy properties of a detached passive building with a sunspace. Table 3 shows the comparison of different characteristics of models Op1 and Op2.

**Table 2.** Parameters of the basic building model used in EnergyPlus™ simulations [4]

Location
Latitude 43.19 N, Longitude 21.54 E, Elevation 202m, ASHRAE climate zone 5A
Ground, Surface solar reflectance 0.20
Space utilization regime
Presence of people 24h/day, 0.0217 persons/m <sup>2</sup>
Design temperature for heating system 20°C
Design temperature for cooling system 25°C
Air infiltration 0.700 ac/h
Lighting (W/m <sup>2</sup> – 100 lux), 5 W/m <sup>2</sup>
Natural ventilation, provision of minimal amount of fresh air per person (24h/day)

**Table 3.** Characteristics of models Op1 and Op2 [4]

Parameter description	Parameter value	
	Model Op1	Model Op2
Building geometry		
Building geometry with shadowing, Dec 21 at 1 pm		
Sunspace window-to-wall ratio (WWR)	WWR <sub>sunspace</sub> =100%	WWR <sub>sunspace</sub> =20%
South-facing façade WWR	WWR <sub>south</sub> =21%	WWR <sub>south</sub> =46%
East-facing façade WWR	WWR <sub>east</sub> =21%	WWR <sub>east</sub> =89%
West-facing façade WWR	WWR <sub>west</sub> =10%	WWR <sub>west</sub> =75%
North-facing façade WWR	WWR <sub>north</sub> =10%	WWR <sub>north</sub> =100%
Sunspace glazing type	Triple, low-emissivity, argon filled	Single, transparent glass, 6 mm
Glazing type of east-, west-, and north-facing façades	Triple, low-emissivity, argon filled	Double, reflective glass, air filled, 6mm/13mm
Façade wall type	Façade wall made of 0.4 m thick concrete and 0.14 m thick thermal insulation	Façade wall made of 0.2 m thick concrete and 0.067 m thick thermal insulation
Shading type of south-facing façade	Horizontal awning 0.5 m	Horizontal awning 0.5 m*
Shading type of east-, west-, and north-facing façades	Brise-soleils, horizontal and vertical awning 1.0 m	Brise-soleils, horizontal and vertical awning 1.0 m*

\*Shading type is the same in both models, only the windows differ in size, which is why awning sizes are also different.

## RESULTS AND DISCUSSION

### Comparative analysis of pollutant emissions from specific types of fuel used for heating and cooling of a detached residential building

Dynamic simulations using EnergyPlus™ were carried out for models Op1 and Op2 of a detached passive building with a sunspace to determine the heating energy requirements. The total energy required for heating was 7,169.08 kWh for model Op1 and 32,772.88 kWh for model Op2.

Table 4 shows the conversion factors used in the calculation of annual primary energy for several fuel types.

**Table 4.** Conversion factor for calculating annual primary energy for the given energy-generating products [5, 6]

Energy-generating product	Conversion factor
Fuel oil	1.2
Gas	1.1
Coal	1.3
Wood biomass	1.0

Based on the obtained data on the heating energy requirements for models Op1 and Op2, the total annual pollutant emissions by fuel type were determined, as shown in Tables 5 and 6.

**Table 5.** Total annual mass of emitted pollutants in relation to heating energy requirements for model Op1 by fuel type [4]

Pollutant	Heating fuel type						
	Natural gas [kg]	Wood biomass [kg]	Pellets [kg]	Fuel oil in furnaces [kg]	Fuel oil in boilers [kg]	Coal in furnaces [kg]	Coal in boilers [kg]
CO <sub>2</sub>	1.59E+03	2.89E+03	2.89E+03	2.40E+03	2.40E+03	3.39E+03	3.39E+03
CO	8.52E -01	1.03E+02	1.29E+01	3.10E+00	1.24E+00	6.71E+01	1.34E+02
CH <sub>4</sub>	1.42E -01	7.74E+00	7.74E+00	9.29E -02	9.29E -02	1.01E+01	1.01E+01
NO <sub>x</sub>	1.99E+00	3.10E+00	2.32E+00	1.55E+00	2.17E+00	5.03E+00	4.36E+00
N <sub>2</sub> O	2.84E -03	1.03E -01	1.03E -01	1.86E -02	1.86E -02	5.03E -02	5.03E -02
SO <sub>x</sub>	1.42E -02	7.74E -01	5.16E -01	4.34E+00	4.34E+00	1.51E+01	3.02E+01
NM VOC	2.84E -01	1.03E+01	5.16E -01	6.19E -01	4.65E -01	1.01E+01	1.01E+01
Cd	1.46E -05	5.16E -05	1.29E -05	9.29E -06	6.19E -05	3.36E -05	1.01E -04
Pb	2.79E -05	1.03E -03	5.16E -04	1.55E -04	6.19E -04	3.36E -03	2.01E -04
TSP	1.42E -02	1.29E+01	2.06E+00	4.65E -01	1.55E -01	8.39E+00	1.34E+01
PM <sub>10</sub>	1.42E -02	1.23E+01	1.96E+00	3.10E -01	9.29E -02	8.05E+00	1.28E+01
PM <sub>2.5</sub>	1.42E -02	1.23E+01	1.96E+00	3.10E -01	9.29E -02	7.38E+00	1.21E+01

**Table 6.** Total annual mass of emitted pollutants in relation to heating energy requirements for model Op2 by fuel type [4]

Pollutant	Heating fuel type						
	Natural gas [kg]	Wood biomass [kg]	Pellets [kg]	Fuel oil in furnaces [kg]	Fuel oil in boilers [kg]	Coal in furnaces [kg]	Coal in boilers [kg]
CO <sub>2</sub>	7.28E+03	1.32E+04	1.32E+04	1.10E+04	1.10E+04	1.55E+04	1.55E+04
CO	3.89E+00	4.72E+02	5.90E+01	1.42E+01	5.66E+00	3.07E+02	6.14E+02
CH <sub>4</sub>	6.49E -01	3.54E+01	3.54E+01	4.25E -01	4.25E -01	4.60E+01	4.60E+01
NO <sub>x</sub>	9.08E+00	1.42E+01	1.06E+01	7.08E+00	9.91E+00	2.30E+01	1.99E+01
N <sub>2</sub> O	1.30E -02	4.72E -01	4.72E -01	8.49E -02	8.49E -02	2.30E -01	2.30E -01
SO <sub>x</sub>	6.49E -02	3.54E+00	2.36E+00	1.98E+01	1.98E+01	6.90E+01	1.38E+02
NMVOOC	1.30E+00	4.72E+01	2.36E+00	2.83E+00	2.12E+00	4.60E+01	4.60E+01
Cd	6.68E -05	2.36E -04	5.90E -05	4.25E -05	2.83E -04	1.53E -04	4.60E -04
Pb	1.28E -04	4.72E -03	2.36E -03	7.08E -04	2.83E -03	1.53E -02	9.20E -04
TSP	6.49E -02	5.90E+01	9.44E+00	2.12E+00	7.08E -01	3.83E+01	6.14E+01
PM <sub>10</sub>	6.49E -02	5.60E+01	8.97E+00	1.42E+00	4.25E -01	3.68E+01	5.83E+01
PM <sub>2.5</sub>	6.49E -02	5.60E+01	8.97E+00	1.42E+00	4.25E -01	3.37E+01	5.52E+01

The results shown in Tables 5 and 6 indicate that the total annual pollutant emissions from specific fuel types decrease when a passive sunspace system with optimal structural and architectural characteristics is installed (model Op1). Reduced mass of emitted pollutants corresponds to the total heating energy savings of a detached building with a sunspace. From an environmental protection perspective, every emission reduction is important.

The obtained results shown in Tables 5 and 6 indicate that the total annual mass of emitted pollutant CO is the largest when the fuel used for heating is coal in low-power boilers; CO annual mass is 134.22 kg for model Op1 and 613.51 kg for model Op2. The lowest emission values for this pollutant occur when natural gas is used; they amount to 0.85 kg for model Op1 and 3.89 kg for model Op2. If natural gas is used instead of coal, the CO emission reduction percentage is 99.37% for model Op1 and 99.37% for model Op2. With regard to maximum (model Op2, coal) and minimum emission values (model Op1, natural gas), the difference is 612.66 kg of CO, or 99.86%.

The obtained results shown in Tables 5 and 6 indicate that the total annual mass of emitted pollutant CH<sub>4</sub> is the largest when the fuel used for heating is coal and it amounts to 10.07 kg of CH<sub>4</sub> for model Op1 and 46.01 kg of CH<sub>4</sub> for model Op2 annually. The lowest emission values for this pollutant occur when natural gas is used and they amount to 0.14 kg for model Op1 and 0.65 kg for model Op2. If natural gas is used instead of coal, the CH<sub>4</sub> emission reduction percentage is 98.69% for model Op1 and 98.59% for model Op2. With regard to maximum (model Op2, coal) and minimum emission values (model Op1, natural gas), the difference is 45.87 kg of CH<sub>4</sub>, or 99.70%.

The obtained results shown in Tables 5 and 6 indicate that the total annual mass of emitted pollutant NO<sub>x</sub> is the largest when the fuel used for heating is coal in furnaces and it amounts to 5.03 kg of NO<sub>x</sub> for model Op1 and 23.01 kg of NO<sub>x</sub> for model Op2 annually. The lowest emission values for this pollutant occur when fuel oil is used in furnaces and they amount to 1.55 kg for model Op1 and 7.08 kg for model Op2. If fuel oil is used instead of coal, the NO<sub>x</sub> emission reduction percentage is 69.18% for model Op1 and 69.23% for model Op2. With regard to maximum (model Op2, coal) and minimum emission values (model Op1, fuel oil), the difference is 21.46 kg of NO<sub>x</sub>, or 93.26%.

The obtained results shown in Tables 5 and 6 indicate that the total annual mass of emitted pollutant N<sub>2</sub>O is the largest when the fuel used for heating is wood biomass and it amounts to 0.1 kg of N<sub>2</sub>O for model Op1 and 0.47 kg of N<sub>2</sub>O for model Op2 annually. The lowest emission values for this pollutant occur when natural gas is used and they amount to 0.00284 kg for model Op1 and 0.013 kg for model Op2. If natural gas is used instead of wood biomass, the N<sub>2</sub>O emission reduction percentage is 97.16% for model Op1 and 97.23% for model Op2. With regard to maximum (model Op2, wood biomass) and minimum emission values (model Op1, natural gas), the difference is 0.46716 kg of N<sub>2</sub>O, or 99.40%.

The obtained results indicate that the total annual mass of emitted pollutant SO<sub>x</sub> is the largest when the

fuel used for heating is coal in low-power boilers and it amounts to 30.20 kg of SO<sub>x</sub> for model Op1 and 138.04 kg of SO<sub>x</sub> for model Op2 annually. The lowest emission values for this pollutant occur when natural gas is used and they amount to 0.01 kg for model Op1 and 0.06 kg for model Op2. If natural gas is used instead of coal, the SO<sub>x</sub> emission reduction percentage is 99.97% for model Op1 and 99.97% for model Op2. With regard to maximum (model Op2, coal) and minimum emission values (model Op1, natural gas), the difference is 138.03 kg of SO<sub>x</sub>, or 99.99%.

The obtained results indicate that the total annual mass of emitted pollutants NMVOC is the largest when the fuel used for heating is wood biomass and it amounts to 10.32 kg of NMVOC for model Op1 and 47.19 kg of NMVOC for model Op2 annually. The lowest emission values for these pollutants occur when natural gas is used and they amount to 0.28 kg for model Op1 and 1.30 kg for model Op2. If natural gas is used instead of wood biomass, the NMVOC emission reduction percentage is 97.29% for model Op1 and 97.27% for model Op2. With regard to maximum (model Op2, wood biomass) and minimum emission values (model Op1, natural gas), the difference is 46.91 kg of NMVOC, or 99.41%. High emission values of NMVOC also occur when coal is used for heating and they amount to 10.7 kg for model Op1 and 46.01 kg for model Op2.

The obtained results shown in Tables 5 and 6 indicate that the total annual mass of emitted pollutant Cd is the largest when the fuel used for heating is coal in low-power boilers and it amounts to 0.000101 kg of Cd for model Op1 and 0.000460 kg of Cd for model Op2 annually. The lowest emission values for this pollutant occur when fuel oil is used in furnaces and they amount to 0.00000929 kg for model Op1 and 0.0000425 kg for model Op2. If coal is used instead of fuel oil in furnaces, the Cd emission reduction percentage is 90.80% for model Op1 and 90.76% for model Op2. With regard to maximum (model Op2, coal) and minimum emission values (model Op1, fuel oil), the difference is 0.00045071 kg of Cd, or 99.78%.

The obtained results shown in Tables 5 and 6 indicate that the total annual mass of emitted pollutant Pb is the largest when the fuel used for heating is coal in furnaces and it amounts to 0.00336 kg of Pb for model Op1 and 0.0153 kg of Pb for model Op2 annually. The lowest emission values for this pollutant occur when natural gas is used and they amount to 0.0000279 kg for model Op1 and 0.000128 kg for model Op2. With regard to maximum (model Op2, coal) and minimum emission values (model Op1, natural gas), the difference is 0.015271 kg of Pb, or 99.82%.

The obtained results shown in Tables 5 and 6 indicate that the total annual mass of emitted pollutants TSP is the largest when the fuel used for heating is coal in low-power boilers and it amounts to 13.42 kg of TSP for model Op1 and 61.35 kg of TSP for model Op2 annually. The lowest emission values for these pollutants occur when natural gas is used and they amount to 0.01 kg for model Op1 and 0.06 kg for model Op2. With regard to maximum (model Op2, coal) and minimum emission values (model Op1, natural gas), the difference is 61.34 kg of TSP, or 99.98%.

The obtained results shown in Tables 5 and 6 indicate that the total annual mass of emitted pollutant PM<sub>10</sub> is the largest when the fuel used for heating is coal in low-power boilers and it amounts to 12.75 kg of PM<sub>10</sub> for model Op1 and 58.28 kg of PM<sub>10</sub> for model Op2 annually. The lowest emission values for this pollutant occur when natural gas is used and they amount to 0.01 kg for model Op1 and 0.06 kg for model Op2. With regard to maximum (model Op2, coal) and minimum emission values (model Op1, natural gas), the difference is 58.27 kg of PM<sub>10</sub>, or 99.98%. High emission values of PM<sub>10</sub> also occur when wood biomass is used for heating and they amount to 12.26 kg for model Op1 and 56.04 kg for model Op2.

The obtained results shown in Tables 5 and 6 indicate that the total annual mass of emitted pollutant PM<sub>2.5</sub> is the largest when the fuel used for heating is wood biomass and it amounts to 12.26 kg of PM<sub>2.5</sub> for model Op1 and 56.04 kg of PM<sub>2.5</sub> for model Op2 annually. The lowest emission values for this pollutant occur when natural gas is used and they amount to 0.01 kg for model Op1 and 0.06 kg for model Op2. With regard to maximum (model Op2, wood biomass) and minimum emission values (model Op1, natural gas), the difference is 56.03 kg of PM<sub>2.5</sub>, or 99.98%.

For all analyzed pollutants except for NO<sub>x</sub> and Cd, the smallest total annual emission mass was registered when natural gas was used as the heating fuel. On the other hand, the use of coal resulted in the largest total annual mass of the following pollutants: CO<sub>2</sub>, CO, CH<sub>4</sub>, N<sub>2</sub>O, SO<sub>x</sub>, Cd, Pb, TSP, and PM<sub>10</sub>. It can also be observed that pollutants NMVOC and PM<sub>2.5</sub> had the largest total annual emitted mass when wood biomass was used as the fuel.

Based on all the results, it can be concluded that there are differences in the calculated pollutant

emissions and these differences should be ascribed to the use of different fuel types and the different amounts of fuels required to achieve thermal comfort in the analyzed models.

## CONCLUSION

The total annual pollutant emission from the combustion of specific fuels used for the heating of detached residential buildings depends on the structural and architectural characteristics of buildings. The emissions, calculated using the emission factor for each pollutant and specified heating fuel, significantly differ in quantity. Such differences are due to the use of different fuel types and different amounts of fuel to achieve thermal comfort in the analyzed models. The smallest total annual mass of emitted pollutants was registered when natural gas was used as the heating fuel, whereas the largest total annual mass was associated with the use of coal and wood biomass. The comparison of two models regarding the total annual mass of emitted CO<sub>2</sub> when coal was used for heating showed that the mass for the optimal model Op1 was 12,102.01 kg, or 78.12%, smaller than for model Op2. This leads to a conclusion that optimization of structural and architectural parameters is justified, not only in terms of achieving thermal comfort but also in terms of reducing the emissions of CO<sub>2</sub>, an essential substance for the greenhouse effect. Optimization of structural and architectural parameters will also reduce the amount of other toxic substances that reduce environmental quality. For the examined urban conditions, such an optimization would most prominently contribute to the reduction of PM<sub>10</sub> and PM<sub>2.5</sub> particulate matter. Comparative analysis of models Op1 and Op2 showed that model Op1, for which the optimization was performed, exhibited 45.52 kg lower annual PM<sub>10</sub> emission than model Op2. Likewise, reduced emission in model Op1 was also found for PM<sub>2.5</sub>, by 43.78 kg, or 78.12%. From the perspective of environmental protection, every reduction of pollutant emission into outdoor ambient air has a significant positive impact both locally and globally.

## ACKNOWLEDGEMENT

This paper is a result of a research supported by the Ministry of Education, Science and Technological Development of the Republic of Serbia according to contract no. 451-03-9 / 2021-14 / 200148.

## REFERENCES

- [1] Đorđević Amelija, "Causal Analysis of Air Quality and Health Risk from Air Pollution", Doctoral dissertation, Faculty of Occupational Safety in Niš, 2010. pp 299.
- [2] Environmental Protection Agency, 2013. „Instruction for calculation of Air Pollutants Emissions from Thermal Power Plants and devices” Ministry of Environmental Protection Republic of Serbia
- [3] Energy, U.D. of, Engineering Reference, EnergyPlus™ Version 9.1.0 Documentation, 2019
- [4] Vukadinović, A. 2020. „Causal explanation of thermal comfort in a residential building with attached sunspace and the emission of pollutants due to fossil fuel combustion”, Doctoral dissertation, Faculty of Occupational Safety in Niš,
- [5] Republic of Serbia, 2011. Ministry of Environmental Protection, Mining and Spatial Planning of the Republic of Serbia, „Pravilnik o energetske efikasnosti zgrada (Rulebook on energy efficiency of buildings)" Službeni glasnik RS”, br 61 (2011): 61-2011.
- [6] Hitchin, Roger, Kirsten Engelund Thomsen, and Kim B. Wittchen. 2018. „Primary Energy Factors and Members States Energy Regulations - Primary Factors and the EPBD,” no. 692447: 4. <https://www.epbd-ca.eu/wp-content/uploads/2018/04/05-CCT1-Factsheet-PEF.pdf>.



## IMPACT OF GREEN ROOFING ON THE ENERGY PERFORMANCE OF A DETACHED PASSIVE RESIDENTIAL BUILDING WITH A TROMBE WALL

Ana Vukadinović<sup>1</sup>, Jasmina Radosavljević<sup>1</sup>, Amelija Đorđević<sup>1</sup>

<sup>1</sup>Faculty of Occupational Safety, University of Niš, Republic of Serbia

[ana.vukadinovic@znrfaq.ni.ac.rs](mailto:ana.vukadinovic@znrfaq.ni.ac.rs), [jasmine.radosavljevic@znrfaq.ni.ac.rs](mailto:jasmine.radosavljevic@znrfaq.ni.ac.rs)

[amelija.djordjevic@znrfaq.ni.ac.rs](mailto:amelija.djordjevic@znrfaq.ni.ac.rs)

**Abstract:** Use of passive systems in detached residential buildings reduces the energy required for heating. Green roofing on such buildings has numerous environmental and energy-related benefits. This paper examines the impact of different green roof types on the energy properties of a detached residential building with a Trombe wall. The method applied is dynamic simulation using the EcoRoof simulation model within the EnergyPlus™ software package. The location of the analyzed building is the city of Niš, Serbia. The results indicate that the use of extensive green roof type in the analyzed model building with a Trombe wall reduces the total energy required for cooling by 3.45%.

**Key words:** green roof, detached residential building, Trombe wall, energy properties

### INTRODUCTION

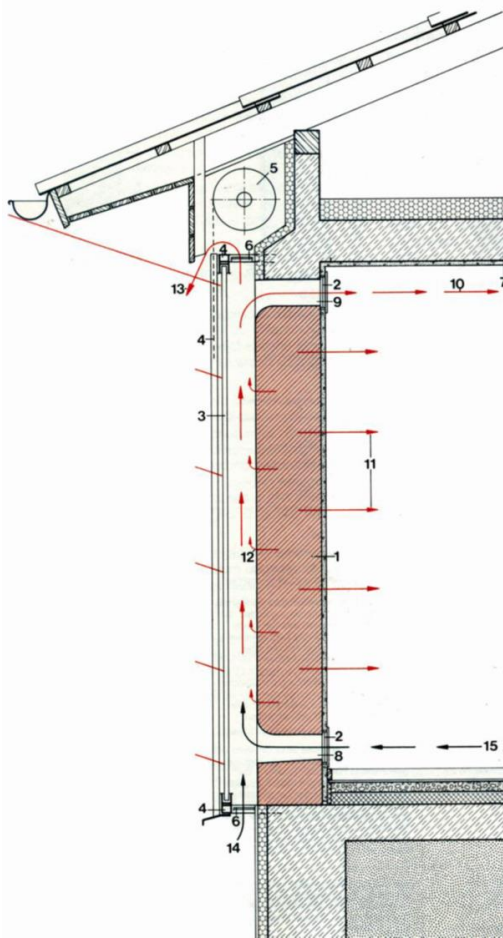
Construction industry accounts for approximately 40% of the total energy consumption, while also being responsible for about 36% of CO<sub>2</sub> emissions [1]. Increased greenhouse gas emissions and the resulting negative environmental effects have urged architects worldwide to reinvestigate the technology of bioclimatic architecture as well as passive solar systems. The use of solar energy in solar and bioclimatic architecture is justified both economically and environmentally [2]. Implementing passive systems in detached residential buildings helps reduce the use of conventional energy-generating products for heating and cooling. Such buildings require special design, because their efficiency depends on the factors such as climate, terrain, terrain inclination, distance from other buildings, orientation, greenery, shading, and so on.

### PASSIVE SYSTEM WITH A TROMBE WALL

In 1967, Félix Trombe used the patent for a massive solar wall to build a passive system into a detached residential house in Odeillo in the Pyrenees, which was later named **Trombe wall (TW)**. The Trombe wall consists of a massive wall painted a dark color, made of a material with excellent thermal storage properties, most commonly brick or concrete. The exterior of the wall is shielded with glass forming an air gap of 2-10 cm. When penetrating the glass, sunlight hits the Trombe wall and heats it [3]. The maximum temperature on the inside of a Trombe wall is usually reached after six to eight hours of sunlight exposure. During the night, the Trombe wall releases heat and heats the indoor space. Heat is transferred to the building's interior by means of conduction and the heat transfer rate depends on the wall material and thickness. To improve heat transfer to the building's interior, ventilation openings may be added to the Trombe wall. The most common variants used in practice are Trombe wall without the ventilation openings or with ventilation openings at the base and at the top. To prevent reversible heat transfer and uncontrolled heat loss during the night or during cloudy periods, the top and bottom ventilation openings need to be closed. The front air space between the glass and the wall may be vented outward by installing air vents, which prevents overheating during the summer [4].

The advantage of a Trombe wall passive system over a direct passive system is smaller indoor temperature fluctuation. A Trombe wall can also be a load-bearing structural element. The disadvantages of Trombe wall passive systems include wall overheating during daytime, slow heat transfer to the building's interior due to conduction, water vapor condensation on the glass, reduced space flexibility, and blocked view of the outdoor surrounding [4].

Figure 1 shows the cross-section of a Trombe wall passive system with the basic elements.



1. Massive wall made of material with high thermal storage capacity, dark colored on the exterior
2. Ventilation openings
3. Double glazing
4. Glass bearing structure
5. Blind – temporary sun protection
6. Air vents
7. Floor structure
8. Opening for letting out cold air from the room; closed at night
9. Opening for letting in warm air; closed in the summer
10. Warm air flow directly into the room
11. Delayed release of accumulated energy
12. Cooling during the summer through dissipation of heat accumulated in the wall
13. Ventilation of the space between the wall and the glass
14. Fresh air intake

**Fig. 1.** Schematic of the basic operating mode of Trombe wall and its elements [4]

Trombe wall passive systems are used for passive heating of buildings. A review of the studies discussed in Kostikov et al. showed that the heating energy savings when using a Trombe wall amounted to 30% during the coldest months and up to 50% during the moderately cold months [2]. In the climate of Portugal, the contribution of Trombe walls in the total heating energy consumption balance is 16% [5].

Recent studies of Trombe wall passive systems also investigated the periods of building cooling in the summer months to prevent indoor overheating. The studies conducted in Mediterranean countries showed that the external temperature of a Trombe wall can reach up to 60°C if no shading system is used [5, 6].

Lohman and Santos found that using Trombe walls in administration buildings can achieve heating energy savings of up to 27%. they also found that the increase of air vents in the Trombe wall can improve its overall functioning [1].

Other studies explored the influence of using phase change and composite materials on Trombe wall heating efficiency [7, 8].

However, the review of previous studies suggests that no studies have examined the influence of green roofing on the efficiency of detached passive buildings with a Trombe wall.

## METHODOLOGY

This paper examines the influence of green roofing on the energy properties of a residential building with a Trombe wall in a humid continental climate in the city of Niš, Serbia. An analysis is performed of the required energy for heating and cooling of a building with a Trombe wall with extensive, semi-intensive, and intensive green roofing (Table 1). The method used to determine the building's energy properties is dynamic simulation by means of EnergyPlus™ software.

### 3.1 Green roof model

A green roof is an open space or garden built as a complex biophysical structure allowing vegetation to grow over a roof structure. Depending on substrate thickness, vegetation type, maintenance, irrigation, and construction cost, green roofs are classified into extensive, semi-intensive, and intensive green roofs (Table 1) [9].

**Table 1.** Green roof types with basic characteristics [9]

	Green roof type		
	Extensive	Semi-intensive	Intensive
Load [kg/m <sup>2</sup> ]	60-150	120-200	250-1000
Substrate thickness [cm]	Up to 15	Up to 15	15-100
Vegetation type	Moss, sedum, grasses	Grasses, shrubs	Perennials, shrubs, and woody plants
Cost	Low	Medium	High
Maintenance	Rare	Occasional	Frequent
Irrigation	Rare	Occasional	Regular
Compatible roof type	Flat or inclined roof	Flat roof	Flat roof
Accessibility	Only accessible for maintenance	Accessible for use to a certain extent	Fully accessible for use (most often for rest and recreation)

The EnergyPlus™ dynamic simulations were carried out using the *EcoRoof* simulation model to examine the energy performance of a model building with a Trombe wall passive system and a green roof [10]. *EcoRoof* considers the heat exchange inside the plant canopy, the influence of plant canopy on heat transfer, evapotranspiration, and heat storage in the substrate. The input parameters for the simulation model include substrate thickness and thermal properties, plant canopy volume, plant height, plant moisture transpiration, substrate moisture, and irrigation. The basic input parameters for the green roof model variants MODEL GR1, MODEL GR2, and MODEL GR3, defined in EnergyPlus™, are given in Table 2. The green roof surface area is 92.16 m<sup>2</sup>.

**Table 2.** EnergyPlus™ input parameters of the green roof over the model building with a Trombe wall [9]

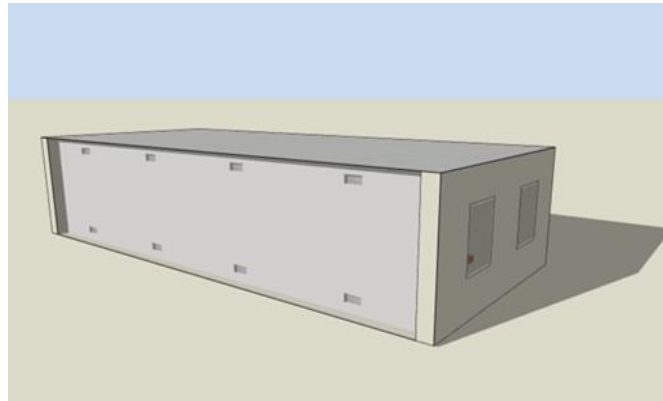
Parameter	MODEL GR1	MODEL GR2	MODEL GR3
Green roof type	Extensive	Semi-intensive	Intensive
Vegetation height (parameter range 0.01-1.0 m)	0.15 m	0.50 m	1.0 m
Leaf area index (LAI) (parameter range 0.001-5.0)	2	3.5	5
Leaf albedo	0.22	0.22	0.22
Emissivity of leaves	0.95	0.95	0.95
Stomatal resistance (parameter range 50.0-300.0 s/m)	150	150	150
Thickness	0.15 m	0.35 m	0.50 m
Substrate albedo	0.14	0.14	0.14
Substrate emissivity	0.90	0.90	0.90

### 3.2 Model of a detached passive building with a Trombe wall and a green roof

The reference model of a detached passive building with a Trombe wall has only the ground floor, with a floor surface area of 92.16 m<sup>2</sup>. The floor base is 14.4 m long and 6.4 m wide. The building height is 3 m.

The Trombe wall is made of 0.2 m thick concrete and shielded with air filled double glazing placed 0.10 m in front of the wall. The Trombe wall covers the entire length of the south-facing façade (14.4

m). The wall also contains top and bottom ventilation openings with the dimensions 0.5x0.2 m. The window-to-wall ratio of the east-, west-, and north-facing façades is WWR=20%. Figure 2 shows the geometry of the model building with a Trombe wall.



**Fig. 2.** 3D representation of the detached building model with a Trombe wall

Table 3 shows the heat transfer coefficients  $U$  for the façade walls, floor and roof structures, and windows of the model building.

**Table 3.** Coefficient  $U$  for the defined thermal envelope elements of the building [9]

Building elements	$U$ [ $W/m^2K$ ]
Façade wall	0.29
Base floor	0.28
Windows	1.50
Flat roof	0.15

The analyzed model building with a Trombe wall is located in Niš, Serbia (43°19' N latitude, 21°54' E longitude, 202 masl). The heat transfer coefficient for all structures in the model's thermal envelope meet the criteria defined in the Rulebook on Energy Efficiency of Buildings [11]. The design temperatures are 22°C for the heating system and 25°C for the cooling system. Air infiltration in the analyzed model variants is 0.700 ac/h.

Three variants of the reference model were developed, each containing one of the green roof types shown in Table 2. The detached building model variants (MODEL GR1, MODEL GR2, MODEL GR3) differ from the reference model only in that they contain a green roof.

## RESULTS

EnergyPlus™ dynamic simulations were carried out and energy properties for the heating and cooling periods were determined for the defined reference model building with a Trombe wall without a green roof and for its green roofed variants (MODEL GR1, MODEL GR2, and MODEL GR3). The simulation results for the annual and monthly heating and cooling energy requirements for the climate of Niš are shown in Tables 4 and 5, respectively.

**Table 4.** Total annual heating and cooling energy requirements of the model building with a Trombe wall and without a green roof and of its green roofed variants MODEL GR1, MODEL GR2, and MODEL GR3

	<i>Energy required for heating [kWh]</i>	<i>Reduction of energy required for heating [%]</i>	<i>Energy required for cooling [kWh]</i>	<i>Reduction of energy required for cooling [%]</i>
<i>Reference model (without a green roof)</i>	6064.13	Ref.	3155.26	Ref.
<i>MODEL TWGR1</i>	6064.13	0%	3155.26	0%
<i>MODEL TWGR2</i>	6073.332	+0.15%	3105.94	-1.56%
<i>MODEL TWGR3</i>	6100.03	+0.59%	3046.29	-3.45%

**Table 5.** Total monthly heating and cooling energy requirements of the model building with a Trombe wall and without a green roof and of its green roofed variants MODEL GR1, MODEL GR2, and MODEL GR3

	<b>Reference MODEL TW (without a green roof)</b>		<b>MODEL TWGR1</b>		<b>MODEL TWGR2</b>		<b>MODEL TWGR3</b>	
	Energy required for heating [kWh]	Energy required for cooling [kWh]	Energy required for heating [kWh]	Energy required for cooling [kWh]	Energy required for heating [kWh]	Energy required for cooling [kWh]	Energy required for heating [kWh]	Energy required for cooling [kWh]
January	1513.23	6.64	1513.23	6.64	1511.26	6.67	1511.08	6.66
February	1191.36	15.58	1191.36	15.58	1192.94	15.52	1195.30	15.45
March	696.32	36.09	696.32	36.09	699.34	35.67	702.85	35.26
April	212.55	109.32	212.55	109.32	216.01	107.54	220.93	105.19
May	14.47	288.67	14.47	288.67	16.07	281.52	18.11	273.44
June	0.01	566.12	0.01	566.12	0.02	554.35	0.05	541.46
July	0.00	796.99	0.00	796.99	0.00	783.36	0.00	766.75
August	0.00	774.67	0.00	774.67	0.00	765.98	0.00	755.58
September	11.29	353.22	11.29	353.22	11.99	348.81	13.05	342.16
October	193.92	176.05	193.92	176.05	196.62	174.67	201.86	172.83
November	716.39	31.20	716.39	31.20	717.29	31.13	722.18	30.80
December	1514.60	0.70	1514.60	0.70	1511.80	0.71	1514.62	0.71

## ANALYSIS AND DISCUSSION

Based on the simulation results, a comparative analysis was performed of the energy properties of the Trombe wall building with different green roof types. Those results indicate that the use of an extensive green roof produced no changes in the heating and cooling energy requirements. When a semi-intensive green roof was used, the total annual heating energy requirements increase by 0.15%, whereas the total annual cooling energy requirements decrease by 1.56%. The biggest decrease of the total annual cooling energy requirements (3.45%) was registered when an intensive green roof was used. However, the intensive green roof increased the total annual heating energy requirements by 0.5%. With regard to cooling energy requirements, the improved efficiency of the intensive green roof over the other two types is influenced by substrate thickness and the type of vegetation, which is characterized by its height and its leaf area index (LAI).

## CONCLUSION

This paper presented a comparative analysis of the energy properties of a detached passive residential building with a Trombe wall and the addition of different green roofing types (extensive, semi-intensive, and intensive). It was determined, using the method of dynamic simulation, that the use of extensive green roofing did not improve the energy properties of the building. In addition, the heating

energy requirements when using semi-intensive and intensive green roofing were higher compared to the reference model without green roofing. The biggest changes in the energy properties were found when intensive green roofing was used, as it reduced the cooling energy requirements by 3.45%. The study considered a detached passive building with a Trombe wall made of concrete and shielded with air filled double glazing. The analyzed wall also contained ventilation openings for air circulation. Further research should focus on the efficiency of green roofing with Trombe walls made of other, modern materials. It would also be beneficial to examine the use of phase change materials in Trombe walls in order to determine whether they help decrease the cooling energy requirements for buildings.

## ACKNOWLEDGEMENT

This paper is a result of a research supported by the Ministry of Education, Science and Technological Development of the Republic of Serbia according to contract no. 451-03-9 / 2021-14 / 200148.

## REFERENCES

- [1] Lohmann, V., Santos, P., Trombe Wall Thermal Behavior and Energy Efficiency of a Light Steel Frame Compartment: Experimental and Numerical Assessments, *Energies*, 13 (2020), 11
- [2] Sergei, K., et al., A Review of the Current Work Potential of a Trombe Wall, *Renew. Sustain. Energy Rev.*, 130 (2020), October 2019, pp. 109947
- [3] Radosavljević J. *Urbana ekologija*. Fakultet zaštite na radu u Nišu, Niš. 2009. [*Urban Ecology*]
- [4] Mila Pucar: *Bioklimatska arhitektura - zastakljeni prostori i pasivni solarni sistemi*, IAUS, Beograd, 2006
- [5] Brito-Coimbra, S., et al., Building Façade Retrofit with Solar Passive Technologies: A Literature Review, *Energies*, 14 (2021), 6
- [6] Simões, N., et al., Energy Performance of Solar and Trombe Walls in Mediterranean Climates, *Energy*, 234 (2021)
- [7] Leang, E., et al., Impact of a Composite Trombe Wall Incorporating Phase Change Materials on the Thermal Behavior of an Individual House with Low Energy Consumption, *Energies*, 13 (2020), 18, pp. 1-32
- [8] Oluah, C., et al., Selection of Phase Change Material for Improved Performance of Trombe Wall Systems Using the Entropy Weight and TOPSIS Methodology, *Energy Build.*, 217 (2020), pp. 109967
- [9] Vukadinović, A., et al., Impact of Green Roofing on The Energy Performance of a Residential Building with a Sunspace, *Tehnika*, 76 (2021), 3, pp. 281-287
- [10] Energy, U.D. of, *Engineering Reference, EnergyPlus™ Version 9.1.0 Documentation*, 2019
- [11] \*\*\*, Pravilnik o energetskej efikasnosti zgrada, Službeni glasnik RS, 061/2011. [Rulebook on Energy Efficiency of Buildings]

## DEVELOPMENT OF HEAT LOAD PREDICTIVE MODELS IN DISTRICT HEATING SYSTEMS USING THE BOOSTING METHOD

Milan Protić<sup>1</sup>, Miomir Raos<sup>1</sup>, Nikola Mišić<sup>1</sup>, Jasmina Radosavljević<sup>1</sup>, Lidija Milošević<sup>1</sup>

<sup>1</sup>University of Niš, Faculty of Occupational Safety, Niš, Serbia

e-mail: [milan.protic@znrfak.ni.ac.rs](mailto:milan.protic@znrfak.ni.ac.rs)

**Abstract:** Today, district heating systems (DHSs) in developed EU countries, especially in Scandinavia, are among the most efficient energy-generating systems for providing citizens with heat in urban areas. In Serbia, there are DHSs in 53 cities and towns, with a total installed capacity of 6,180 MW. Despite the expansion of DHSs in Europe, the operation of DHSs in Serbia has been facing numerous issues in recent years. One of the possible ways of enhancing the efficiency of DHS operation, with relatively small investments, is through improvement of the existing inefficient control strategies. Heat load predictive models of individual consumers have a central role in these novel and intelligent control schemes. In this paper, boosting method was used for the development of predictive models, while the data from two DHSs in Serbia were used for model development and verification. The obtained results indicate that the proposed method provides acceptable predictive performance. However, further research and improvement is needed before any practical implementation.

**Key words:** district heating systems, control, boosting method

### INTRODUCTION

The basic idea of district heating systems (DHSs) is the use of local fuel, or heat sources that would otherwise remain unused, in order to meet the heating demands of local consumers using a centralised heat source and a distribution network that delivers the heat to end consumers.

Efficient and economic operation of DHSs is essentially linked to the possibility of meeting three fundamental prerequisites through the following [12]:

- existence of proper economical and environmentally acceptable heat sources;
- concentration of heat consumers;
- possibility of building an efficient distribution network between the heat source and the consumers.

The economy of heat energy production is directly connected to the type of energy-generating product used and the method of its transformation into heat energy. To make DHSs competitive with devices for local heat energy generation, it is necessary to deliver the largest portion of the heat energy from one or more strategic heat sources, such as the following [9]:

- cogeneration plants;
- incineration plants;
- boiler facilities for the burning of 'bulky' biofuels that are difficult to handle and impractical or impossible to use in local combustion devices (e.g. wood waste);
- solar and geothermal energy sources;
- industrial facilities that produce waste heat.

DHSs are not a new technology. One of the oldest DHSs is located in Chaudes-Aigues, France. This DHS uses a geothermal heat source with a temperature of 82 °C and it has been in use since the 14th century.

According to [11], the first commercial DHS, similar to those in use today, was built in Europe, in Hamburg, in 1921. The driving force behind DHS development was the steep price of fossil fuels after WW1. The DHS in Hamburg was soon followed by the systems in Kiehl in 1922, Leipzig in 1925, and Berlin in 1927. Outside Germany, DHSs were available in Copenhagen in 1925, Utrecht in 1927, Paris in 1930, Zurich and Stockholm in 1933, and in Helsinki in 1953. In Reykjavik, a DHS with a geothermal heat source was put into operation in 1930 and today it supplies heat almost to 160,000 people, which is almost the entire city. In Russia, the first DHS was built in 1902, modelled after the New York City DHS. However, the expansion of DHSs in Russia only began with Lenin's grand plan of the country's electrification, which commenced in the 1920s. Today, the Moscow DHS is the largest DHS in the world, followed by the one in Saint Petersburg.

The first DHS in Serbia was built in 1901 [10]. A company named Pohlmann & Kurz from Budapest started the project of delivering steam central heating to kitchens, wash houses, and pavilions of the state General Hospital in Vračar, Belgrade. The plant was put into operation on 5 August 1906.

Historically, there are four generations of DHS development. DHSs have undergone a series of considerable changes, from the first DHS that appeared in the USA in the late 19th century to modern fourth generation systems that are still in their infancy in countries with a long-standing tradition of DHSs. The fourth generation is an advanced concept in which DHSs are viewed as an integral and inseparable part of future sustainable energy-generating systems. According to this concept, DHSs should be considered a part of intelligent energy-generating systems, which combine intelligent electric, heat, and gas networks to obtain optimal solutions, both for every individual sector and for the energy system as a whole [7]. The chief characteristic of fourth generation DHSs is a drastic reduction of heat exchanger temperature levels to 30-70 °C, which is why such systems are also called low-temperature DHSs.

Even though DHSs in Serbia have a very long tradition, in recent years the operation of these systems in many Serbian cities has been ridden with numerous problems. Uneconomic operation is directly connected with the way heat energy is produced and the main energy-generating product. Namely, all DHSs in Serbia today use fossil fuels as the energy-generating products, most often natural gas, which is used exclusively for heat production. This method of heat production is almost non-existent in the EU, and where it does exist, it is used as a backup facility to be activated only in extraordinary circumstances. Consequently, the price of the heat produced in DHSs in Serbia thus exceeds the price of heat energy obtained from local heating devices that use the same energy-generating product. The main reason for the price discrepancy is the fact that, in addition to the cost of energy-generating products, DHSs have to add the costs pertaining to system maintenance and distribution network maintenance, employee salaries, overhead, and so on. Furthermore, the price of heating from DHSs also exceeds the price of other competitive alternatives, such as individual household heating using gas, coal, wood, or electricity (storage heaters), which makes DHSs unsustainable. This leads to a paradox that the price of the heat delivered from DHSs by far exceeds the price of heating using individual heating devices, and even the price of heating using electricity.

In addition to the issue with energy-generating products, which are the most noticeable, there are numerous other issues concerning the operation of DHSs. All heat sources are extremely oversized. The distribution network in most Serbian DHSs was built in stages, often without proper paperwork, which is why it is hydraulically unbalanced, preventing normal delivery of required heat to all the consumers. Additionally, some Serbian DHSs still use outdated equipment in district heating substations, which prevents the regulation and measurement of the heat delivered to consumers.

Optimization of DHSs in Serbia, which would significantly reduce heat production and distribution costs, is possible in two key ways:

- by substituting the existing heat sources with 'strategic' ones (cogeneration facilities, incineration, geothermal and solar systems) and
- by changing the manner of DHS operation through introduction of modern and intelligent control strategies aimed towards balancing the produced and consumed heating energy.

Transformation of heat sources in DHSs and fuel substitution should be the strategic choice of the country, but these processes require considerable time and proper financial mechanisms, which are difficult to secure. Therefore, the current situation requires measures that can optimize the operation of DHS in as little time as possible and with low investment costs. One option with enormous potential is to improve the current control strategies in DHSs.

The major issue with the current method of centralized control of DHSs is that the role of consumers is marginalized and that the thermal inertia of the network and the consumers is not considered at all. The result is a high discrepancy between the produced heat on the one hand and the actual heat demand on the other, which in turn leads to serious losses. Therefore, DHSs need to be managed with the aim of balancing the amount of produced heat with the amount of heat demanded by the consumers, any time and as much as possible.

This approach is called demand side management and it has been used for years in electric power systems to balance electricity production with consumer demand. According to [8], demand side management is a series of measures for improving an energy system in relation to consumption and consumer behaviour.



Balancing the amount of heat produced with the actual consumer demand in DHSs is possible only if predictive thermal models of all, or at least key, consumers are known. With predictive thermal models of consumers and reliable tools for outdoor temperature prediction, it is possible to precisely determine the future values of heat load, which could then be used to control heat production. The model's prediction horizon should be established according to the distribution network configuration.

This paper explains the procedure of creating predictive models of consumers using boosting method. In addition, conventional tools for statistical analysis are used to conduct an unbiased verification of predictive performance of the developed models. The predictive models were created and tested using the data from two heat substations, one from DHSs in Niš and other from DHS in Novi Sad, Serbia.

## MATERIAL AND METHODS

### Data acquisition – district heating systems in Niš and Novi Sad

The data used to create predictive thermal models of consumers were acquired from heating substations of the DHSs in the cities of Niš and Novi Sad. Data acquisition was conducted without external influences on the observed system, so this cannot formally be considered an experiment, which would require controlled influence on the system and monitoring of the effects, but rather an observational study, where there is no influence whatsoever from the researcher. However, in the literature, the concept of observational study is more often associated with medical and social studies than with studies in the fields of natural science and engineering. Accordingly, to conform to the convention, the term experiment will be used below instead of observational study.

In Niš, data acquisition was conducted during the 2009/2010 heating season. In addition to the data from the Niš DHS, data from the DHS in Novi Sad were also acquired, but during the 2010/2011 heating season. The goal of such an approach was to examine the universality of the methodology and algorithms used to create predictive thermal models of consumers and the possibility of replicating these methods and algorithms in another DHS.

Descriptive statistics for the data acquired from the Niš and Novi Sad DHSs are shown in Tables 1 and 2, respectively.

**Table 1.** Descriptive statistics of time series – heating substation in the Niš DHS

Variable	Min.	Max.	Mean	Standard deviation
Outdoor temperature [°C]	-10.77	19.08	5.31	5.26
Primary supply temperature [°C]	14.02	88.47	52.11	19.34
Primary return temperature [°C]	12.21	55.42	38.08	8.84
Water flow [ml/s]	0.00	6.57	3.62	2.59

**Table 2.** Descriptive statistics of time series – heating substation in the Novi Sad DHS

Variable	Min.	Max.	Mean	Standard deviation
Outdoor temperature [°C]	-7.60	24.40	5.70	6.52
Primary supply temperature [°C]	21.77	102.40	59.80	16.72
Primary return temperature [°C]	21.10	52.42	36.96	5.81
Water flow [ml/s]	0.00	1630.8	1310.1	282.00

### Boosting method

In statistical learning methods, model creation begins with experimentally obtained data. Models are created using the method of supervised learning, whereby training pairs need to be prepared in advance. Standard regression methods, neural networks, and support vector machines are most often used. Use of these methods yields unique predictive models, which are also called strong predictive models.

An alternative approach that currently dominates the field of machine learning involves the creation of a large number of models that are combined and that act synergistically when solving specific classification and regression problems. Such an approach produces ensemble models, while the models used to create ensemble models are called base learners. Models with high bias are most often used as

base learners, although there are examples of combining strong models, e.g. neural networks, into ensembles [4].

The boosting method is in fact an iterative procedure for minimizing the criterion function by adding new base learners, which contribute to the greatest reduction of estimation error in a given iteration phase. In other words, for the case of squared criterion function, in each subsequent iteration new base learners, which best estimate the residuals of the previous model, are added to the main model. Values of model parameters determined in the previous iteration are not substituted by the new iterations. With this procedure, successive addition of new base learners will produce the final model, which is essentially an ensemble, or a combination, of the previously obtained base learners. Since the addition of new models ‘boosts’ the initial model, the procedure has been termed boosting.

### Mathematical formulation of the boosting method

Let there be a training data set  $\{\mathbf{x}_i, y_i\}$ ,  $i=1, \dots, n$ , where  $\mathbf{x}_i$  are the inputs and  $y_i$  the outputs of an observed system. The aim is to reconstruct the mapping  $f: \mathbf{x} \rightarrow y$  by estimation  $\hat{f}(\mathbf{x})$  so as to minimize a given criterion function  $L(y, f(\mathbf{x}))$ :

$$\hat{f}(\mathbf{x}) = \arg \min_{f(\mathbf{x})} L(y, f(\mathbf{x})) \quad (1)$$

The common procedure for determining  $f(\mathbf{x})$  involves restricting the search for potential estimation functions to the parameter family of functions  $f(\mathbf{x}, \theta)$ . This way, the problem is reduced to a numerical optimization through iterative updating of the values of model parameters.

The algorithm for applying gradient boosting methods can be represented as the following series of steps [3]:

**Step 1** – Definition of all the necessary input quantities:

- training data set;
- criterion function selection;
- base learner type selection;
- setting of the number of iterations.

**Step 2** – Initialization of the initial base learner  $\hat{f}_0(\mathbf{x})$ .

**Step 3** – For  $k=1$  to  $m$  (number of iterations):

- calculate gradient  $g_k(\mathbf{x}_i) = \left. \frac{\partial L(y_i, f(\mathbf{x}_i))}{\partial f(\mathbf{x}_i)} \right|_{f(\mathbf{x}_i)=f_{k-1}(\mathbf{x}_i)}$  ;
- calculate  $(\theta_k, \alpha_k) = \arg \min_{\theta, \alpha} \sum_{i=1}^n (-g_k(\mathbf{x}_i) + \alpha h(\mathbf{x}_i, \theta))^2$  ;
- calculate  $\rho_k = \arg \min_{\rho} \sum_{i=1}^n L(y_i, f_{k-1}(\mathbf{x}_i) + \rho h(\mathbf{x}_i, \theta_k))$  ;
- update  $f_k(\mathbf{x})$  to  $f_k(\mathbf{x}) = f_{k-1}(\mathbf{x}) - \rho_k h(\mathbf{x}, \theta_k)$ .

### RESULTS AND DISCUSSION

Prior to the creation of predictive model, the developed programming code was validated to be used to create the models. A time series obtained from a Mackey-Glass delay differential equation was chosen for testing [13]. A surrogate series of 1,000 pieces of data was generated, whereby the first 500 pieces were used for training and the remaining 500 for testing (validation). The validation test results are shown in Table 3.

**Table 3.** Prediction results using the boosting model for data from a Mackey-Glass time series

Method	Training set RMSE	Test set RMSE
Boosting with generalised linear model (GLM)	0.1075523	0.1194056

The obtained results correspond to a great extent to the results from other sources [1], [2], [5] and [6]. The predictive models were created in several stages. First, the models with 48 and 24 previous successive hourly values of heat load were developed. These values were chosen to account for the daily variability of heat load. To create the models (training data set), 2,000 observations were used for both the Niš and the Novi Sad DHS, whereas the test data set included 1,180 observations for the Niš and 1,517 for the Novi Sad DHS. Predictive modelling was performed using generalized linear models as base learners.

The obtained prediction results for the test data set are shown in Table 4. Root-mean-square error (RMSE) was used as the criterion for assessing the predictive performance of the developed models, as it is the usual criterion in this type of analysis.

**Table 4.** Predictive performance of the Boosting heat load model for DHSs in Niš and Novi Sad; input variables: heat load with 1-48h and 1-24h delays

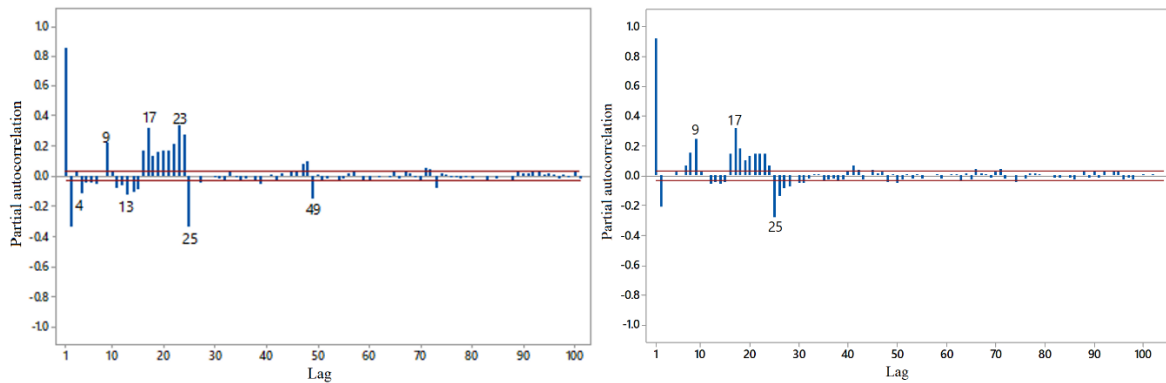
Prediction horizon	Predictive performance: Boosting method			
	DHS Niš		DHS Novi Sad	
	RMSE [kW] Previous 48h values	RMSE [kW] Previous 24h values	RMSE [kW] Previous 48h values	RMSE [kW] Previous 24h values
1h ahead	25.669	26.992	18.476	18.988
2h ahead	31.227	32.151	22.662	23.580
3h ahead	32.862	33.492	24.134	25.238
4h ahead	33.355	33.942	25.076	25.874
5h ahead	33.567	34.140	25.673	26.227
8h ahead	33.624	34.202	26.671	26.961
12h ahead	33.694	34.072	26.697	27.028
24h ahead	33.787	34.110	27.498	27.535

The results from the table above primarily indicate that prediction error increases with the increase of the prediction horizon, which was expected.

In addition, it is evident that predictive performance declines to a certain extent with the reduction in the number of input variables. This conclusion can be generalized for the DHSs in both considered cities. However, it has to be noted that a drastic reduction of the number of input variables greatly reduces the computational cost, which is particularly important considering that the end goal of predictive modelling is to implement the models in the control system for the entire DHS. Under such circumstances, computational cost is of paramount importance, because predictive models need to be created for every individual consumer, whose number can reach up to tens of thousands in highly developed DHSs.

An additional problem is that predictive models developed this way contain a large number of variables that are colinear. Therefore, graphs of the partial correlational function were produced in the following step to identify the most influential input variables.

The autocorrelation function graphs for the Niš and Novi Sad DHS data are shown in Figure 1.



**Fig. 1.** Partial autocorrelation function for heat load (left: DHS Niš, right: DHS Novi Sad)

Based on the obtained results, the final stage of the study involved the creation of new predictive models. The predictive performance of the new models for the same horizons is given in Table 5.

**Table 5.** Predictive performance of the Boosting heat load model for DHSs in Niš and Novi Sad; input variables: heat load with delay based on partial autocorrelation function

Prediction horizon	Predictive performance: Boosting method	
	Data – DHS Niš	Data – DHS Novi Sad
	RMSE [kW] test set	RMSE [kW] test set
1h ahead	26.568	18.473
2h ahead	31.458	22.695
3h ahead	33.326	24.216
4h ahead	33.875	25.148
5h ahead	34.095	25.726
8h ahead	34.054	26.807
12h ahead	34.128	36.597
24h ahead	33.904	27.568

Results shown in Table 5 cannot lead to a general conclusion, because the results are inconsistent and greatly depend on the extent of the prediction horizon. In the majority of the cases, there was some improvement. It should also be noted that the developed predictive models were considerably simplified compared to the model from the previous stage.

## CONCLUSION

This paper discussed the use of the boosting method in predictive modelling of individual consumer heat load in district heating systems. The boosting method belongs to the group of ensemble methods in statistics and machine learning, which are based on submodels called base learner functions.

The relevant literature contains numerous validations of the efficiency of this method, which motivated us to use it for predictive modelling of consumers in district heating systems. The models were created using archive data from two district heating systems in Serbia (Niš and Novi Sad) collected during the 2009/2010 heating season.

Modelling was performed successively over several stages. The large number of input variables in the initial models was gradually reduced. In the final iteration, the input variables were determined according to the partial autocorrelation function graph. It was determined that a decline in the number of predictors causes only minimal improvement of the models' predictive performance. Nevertheless, this procedure produces considerably simpler models that are computationally less demanding. This is especially important considering that the primary goal is to integrate the developed models into a control environment. The conclusion is that the boosting method can be used for short-term prediction of consumer heat load in district heating systems, but further improvements are necessary.

In order to further improve the predictive performance of the models, it is also necessary to include exogenous inputs, which will presumably raise the quality of the developed models, of course, provided that their inclusion does not significantly increase computational costs. This will be the topic of a future study.

## ACKNOWLEDGEMENT

The authors would like to express gratitude to the Ministry of Education, Science and Technological Development of the Republic of Serbia for financing support to this researches.

## REFERENCES

- [1] Chen, Y., Yang, B., Dong, J., Abraham, A. (2005). Time-series forecasting using flexible neural tree model. *Information sciences*, 174(3), 219-235
- [2] Cho, K.B., Wang, B.H. (1995) Radial basis function based adaptive fuzzy systems their application to system identification and prediction, *Fuzzy Sets and Systems* 83, 325–339
- [3] Friedman, J. H. (2002). Stochastic gradient boosting. *Computational Statistics & Data Analysis*, 38(4), 367-378
- [4] Hansen, L., and Salamon, P. (1990). Neural network ensembles. *IEEE Trans. Pattern Anal. Mach. Intell.* 12, 993–1001.
- [5] Jang, J.-S.R., Sun, C.-T., Mizutani, E. (1997) *Neuro-fuzzy and soft computing: a computational approach to learning and machine intelligence*, Prentice-Hall, Upper Saddle River, NJ.
- [6] Kim, D., Kim, C. (1997) Forecasting time series with genetic fuzzy predictor ensembles, *IEEE Transactions on Fuzzy Systems* 5, 523–535.
- [7] Lund, H. (2009). *Renewable energy systems: the choice and modeling of 100% renewable solutions*. Academic Press.
- [8] Palensky P, Dietrich D. (1999) Demand side management: demand response, intelligent energy systems, and smart loads. *IEEE Trans Ind Inf* 99. <http://dx.doi.org/10.1109/TII.2011.2158841>.
- [9] Persson, U, Werner, S. (2012). District heating in sequential energy supply. *Appl. Energy* 95, 123–131.
- [10] Todorović, B. (2005). *Projektovanje postrojenja za centralno grejanje*. Faculty of Mechanical Engineering, University of Belgrade (in Serbian)
- [11] Werner, S. (1984). *The heat load in district-heating systems*. PhD thesis, Chalmers University of Technology, Sweden.
- [12] Werner, S. (2004). District heating and cooling. *Encyclopedia of Energy*;1:841–8.
- [13] <http://www.mathworks.com/help/fuzzy/examples/chaotic-time-series-prediction.html>

## ELIMINATION LEAN WASTE IN THE PRODUCTION PROCESS

Ranka Gojković<sup>1</sup>, Slaviša Moljević<sup>1</sup>, Bogdan Marić<sup>1</sup>, Vlado Medaković<sup>1</sup>

<sup>1</sup>University of East Sarajevo, Faculty of Mechanical Engineering, East Sarajevo,  
Bosnia and Herzegovina

e-mail: [ranka.gojkovic@ues.rs.ba](mailto:ranka.gojkovic@ues.rs.ba)

**Abstract:** To survive in the market, it is necessary to develop a new approach to improve the production process. Waste elimination represents great potential in terms of improving the production process. To eliminate wastes, it is necessary to perform an analysis of the work process, to identify all the causes that lead to wastes and, based on that, to plan and implement improvement measures to reduce or eliminate these wastes. In this paper, it is proposed to eliminate Lean wastes by eliminating the failures that lead to them. Identifying and eliminating failures also leads to eliminating wastes. The Ishikawa diagram was used to identify failures. By applying the failures elimination method, Lean waste will also be eliminated.

**Keywords:** Lean manufacturing, Lean waste, failures, elimination waste

### INTRODUCTION

With the accelerated development of new technologies, there is pressure on the management of production organizations to continuously change and improve business processes. Performance indicators can be measured by the effectiveness and efficiency of the production process. In an effective and efficient production process, quality and competitive products will be produced, which leads to higher profits. Profit is related to the level of productivity, it is related to the ability of the company's management to optimize the output compared to the input used. The inputs used in the production process include resources such as raw materials, energy, capital and human resource, while the manufactured product represents the output from the production process. An input that is higher than the output will cause waste for the company such as low productivity and high production costs. Eliminating wastes that occur in manufacturing companies can increase efficiency, effectiveness and reliability, as well as reduce production costs. The concept of Lean production defines the eight wastes that most commonly occur in a manufacturing industry. Each waste significantly affects the production time, price and product quality, which makes the company less competitive in today's market. In order to eliminate this type of waste, it is necessary to perform an analysis of the work process, to identify all the failures that lead to the formation of wastes and to plan and implement improvement measures to reduce or eliminate these wastes. Preventive action to prevent wastes in the production process is one of the most effective ways to increase the effectiveness and reliability of both the production process and the company as a whole.

Many authors have considered improving the effectiveness of the production process by reducing and eliminating wastes, or anything that does not add value to a product or service [1][2]. The elimination of wastes represents great potential in terms of improving the production process. It is crucial to identify wastes, as well as their values, to develop their own knowledge management base and to understand that sustainable improvement requires a culture of continuous improvement [3]. One way to reduce or eliminate wastes is to identify the failures that lead to these wastes. Reducing or eliminating failures in the production process not only improves the production process but also improves the business of the entire company, and thus achieves business goals [4].

In this paper, the identification of all failures that lead to Lean wastes is performed and suggestions for their elimination are given.

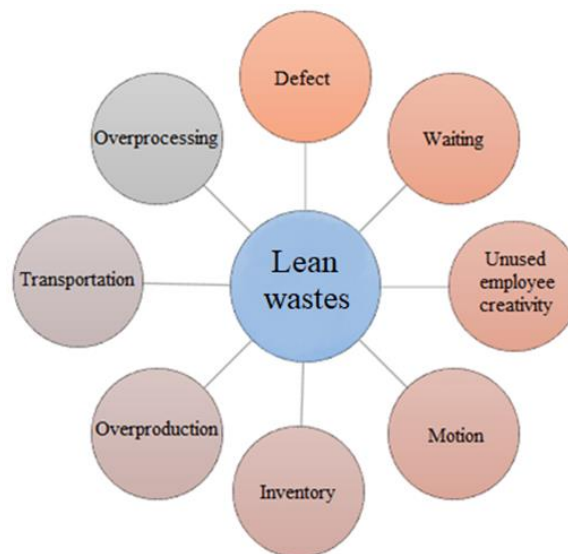
### MATERIAL AND METHODS

#### Lean waste

Lean thinking is defined as initiatives that focus on improving production efficiency and productivity by concentrating on removing wastes and creating value from a customer perspective [11]. Wastes are activities that do not add value or all activities that the customer does not want to pay [12].

Researchers at the Lean Enterprise Research Center (LERC) pointed out that for most manufacturing operations: 5% of activity adds value; 35% of activities do not add value but are necessary; 60% of activities do not add value at all and represent wastes [1]. The authors [2] conducted research in the industry of manufacturing companies producing electronic goods in North Sumatra. They used value flow mapping to visualize the actual state of the production process and to determine the classification of value-added activities and non-value-added activities. Their results show that 89% of the activities do not add value and 11% of the activities add value.

Numerous types of wastes can appear in the production process. According to traditional Lean production, there are seven types of wastes, which are identified by Ohno [13]: Waiting, Transportation, Defect, Overproduction, Motion, Overprocessing, and Inventory. Liker [14] introduced Unused employee creativity as the eighth waste. Eight Lean wastes are shown in Figure 1. These wastes are activities that consume resources and that the customer is not willing to pay for. Each waste significantly affects the production time, price and product quality.



**Fig. 1.** The eight wastes of Lean manufacturing

*Waiting* represents a waste of productive time. Unnecessary waiting occurs in the following situations: when the worker is waiting for the material to be delivered, when the work item is waiting because the machine is not free, when the work item is waiting due to overproduction, when the work item has to be reworked due to bad quality of processing, due to incomparable performance of workers/machines, machine failures, waiting for information, etc.

*Transportation* implies unnecessary movement of materials, semi-finished products and products through the system. The existence of a transport process creates many costs that affect the increase in total production costs. Unnecessary transport often leads to multiple handling and excessive movements.

*Defect* implies any defects in products or services. Defects are products or services that do not meet customer specifications or expectations, causing customer dissatisfaction.

*Overproduction* means producing more products even before there is a real need. This is one of the most serious wastes in the company. This waste causes the engagement of storage space and means of transport.

*Motion* represents every unnecessary movement that workers have to perform during their work.

*Overprocessing* is unnecessary operations or actions that do not increase quality or that increase quality that is not required by the customer and which as such the customer is not willing to pay. Very often employees are not able to identify this type of wastes because due to daily obligations they cannot think about whether it is necessary to change the way activities are realized.

*Inventory* creates significant storage costs and, therefore, reduces the competitiveness of the company or the flow of value in which they exist. Inventories are considered an unnecessary expense in modern management concepts.

*Unused employee creativity* refers to the underutilization of people, especially their ideas and their creative contribution in order to improve production processes. This waste involves ignoring ideas or not hiring workers to create new ideas.

### **Elimination lean waste**

Effective wastes management means taking adequate measures at the right time with the least expenditure of the necessary resources, which should lead to a reduction of added value in companies from different economic domains.

The paper [5] introduced the assumption that wastes should be ranked, and then measures should be taken to reduce or eliminate wastes, which is in the first three places in the ranking. A method for prioritizing wastes reduction procedures during a product development system was proposed by [6]. The paper defines a set of wastes specific to product development that covers all elements of the product development system. A procedure for calculating the relationship between wastes via indirect relations is described and a heuristic for giving priorities from highly related subsets of wastes is presented. In [7] presented the Lean wastes identification model. This paper focuses on the identification and elimination of the three largest Lean wastes.

Many researchers and practitioners suggest that the ordering of management initiatives aimed at eliminating or reducing wastes should be based on the priorities of failures whose implementation leads to the emergence of wastes [8][9]. A large number of companies, even those with many years of Lean experience, are still struggling to reduce waste from their processes. It turned out that the most difficult part is not by removing the waste itself, but by identifying and highlighting it [10].

In [8] performed the assessment of wastes in the rubber production process. In the first phase, the identification of wastes was performed. The three largest wastes during the tire production process were identified. The Ishikawa diagram is used to identify the underlying causes that lead to these three wastes. Traditional FMEA is used to determine failures and their impact on wastes in the tire manufacturing process.

During the work process, people make failures. When failures are made and not detected in time, wastes will appear at the end of the process. However, if failures can be prevented before they occur, then they could be avoided and wastes in the manufacturing process.

In this paper, it is proposed that the reduction and elimination of Lean wastes be done in a way that first eliminates the failures that lead to them.

In the literature, as well as in practice, there are no rules or recommendations on how to determine failures at the level of each Lean wastes. The identification of failures is often based on the assessment of decision makers (DM) as in this paper.

Based on the DM assessment, failures leading to Lean waste were identified in 24 SMEs in Bosnia and Herzegovina.

According to Lean thinking, reducing wastes will improve every indicator of a company's business performance: profitability, quality, employee satisfaction, customer satisfaction, etc.

## **RESULTS AND DISCUSSION**

### **Identification failures in production process**

Understanding the eight wastes and acting to reduce them can lead to improved efficiency, effectiveness and reliability of the production process. The first step in achieving this goal is to identify all the failures that lead to Lean wastes. After identifying failures, it is necessary to take measures to reduce or eliminate wastes, which is the goal of every organization.

The Ishikawa diagram was used to identify and graphically represent the failures that lead to the formation of wastes in the production process. In the literature, the Ishikawa diagram is also called the cause-effect diagram; because of its appearance, it is also called the fishbone diagram. This diagram makes it possible to easily see all the causes and consequences of the considered problem in one place. The process of constructing a diagram consists of defining the consequence. In this case, the consequence is manifested through a reduction in the effectiveness of the production process. Then the



process of defining possible causes (eight Lean wastes), construction and further development of the diagram to the selection of a smaller number of causes (failures) is performed.

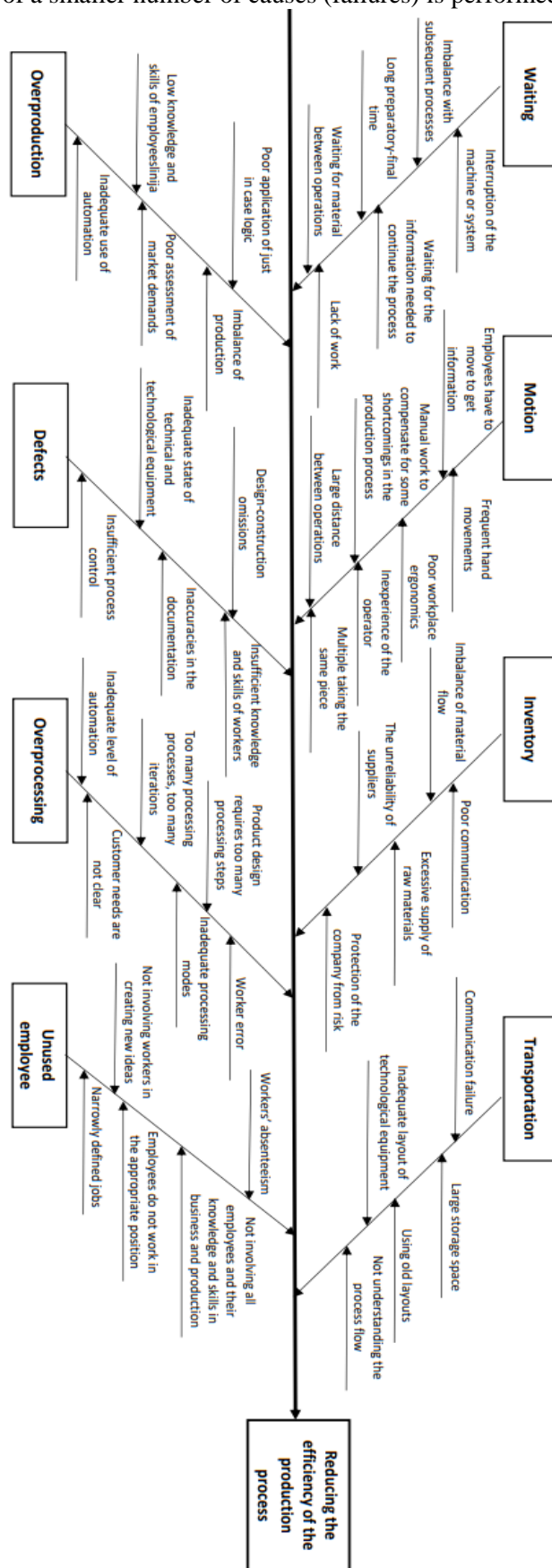


Fig. 2. Ishikawa diagram

Identifying failures at the level of the production process that can lead to wastes that are defined in the Lean concept of production is done based on the assessment of DM. They base their assessments primarily on experience, records and best practice results. The Ishikawa diagram with all identified failures is shown in Figure 2.

The following is an overview of all failures that cause Lean wastes.

Waiting is caused by the following failures: Waiting for material between operations, Interruption of the machine or system, Lack of work, Waiting for the information needed to continue the process, Imbalance with subsequent processes and Long preparatory-final time.

Transportation is caused by the following failures: Not understanding the process flow, Inadequate layout of technological equipment, Large storage space, Communication failure and Using old layouts.

Defect is caused by the following failures: Insufficient knowledge and skills of workers, Inaccuracies in the documentation, Insufficient process control, Design-construction omissions and Inadequate state of technical and technological equipment.

Overproduction is caused by the following failures: Imbalance of production lines, Inadequate use of automation, Poor assessment of market demands, Poor application of just in case logic and Low knowledge and skills of employees.

Motion is caused by the following failures: Poor workplace ergonomics, Large distance between operations, Frequent hand movements, Multiple taking the same piece, Employees have to move to get information, Manual work to compensate for some shortcomings in the production process and Inexperience of the operator.

Overprocessing is caused by the following failures: Inadequate level of automation, Inadequate processing modes, Worker error, Product design requires too many processing steps, Too many processing processes, too many iterations and Customer needs are not clear.

Inventory is caused by the following failures: Imbalance of material flow, The unreliability of suppliers, Excessive supply of raw materials, Poor communication and Protection of the company from risk and unexpected events.

Unused employee creativity is caused by the following failures: Narrowly defined jobs, Not involving workers in creating new ideas, Employees do not work in the appropriate position, Not involving all employees and their knowledge and skills in business and production processes and Workers' absenteeism.

### **Measures for elimination of failures**

After identifying failures, it is necessary to apply appropriate Lean tools as well as quality tools in order to reduce and eliminate failures, which ultimately leads to a reduction of Lean wastes. Some of the tools that need to be applied to eliminate these failures are: Just in time, Poka-Yoke, 5S, Kanban, Control chart, PDCA, SMED, Brainstorming, etc.

The problem of eliminating failures requires the consumption of both material and other resources. In order to optimize the consumption of resources, it is necessary to apply as many tools that are already in use. Most tools can be applied simultaneously. The period of application and education of employees for their application is not long. In SMEs that have implemented Total Quality Management - TQM and quality management system according to ISO 9001, most of these tools are already in use and do not require additional investment and additional costs.

### **CONCLUSION**

By identifying the failures that lead to Lean wastes, all wastes in the production process can be seen. Elimination or reduction of failures affects the reduction of wastes, which leads to a significant improvement of the production process. The list of identified failures contains a high degree of DO subjectivism and it is proposed to adapt to each company. To reduce wastes in the production process it is necessary to take measures to reduce the failures that lead to these wastes. Quality managers and production managers of manufacturing companies can recommend the application of quality tools and Lean tools, to prevent failures and at the same time create the opportunity to increase the efficiency and effectiveness of the production process, and maintain reliability for a long time. Systematic waste

disposal can result in faster processes, lower costs, higher quality, more satisfied workers and, most importantly, more satisfied customers.

## REFERENCES

- [1] Pipunić, A., Grubišić, D., Suvremeni pristupi poboljšanjima poslovnih procesa i poslovna uspešnost. *Ekonomika misao i praksa*, No.2, pp. 541-572, 2014.
- [2] Nasution, A. A., Siregar, I., Anizar, Nasution, T. H., Syahputri, K., Tarigan, I. R., Lean Manufacturing Applications in the Manufacturing Industry. *MATEC Web of Conferences*, Vol. 220, 02005, 2018.
- [3] Melton, T., The benefits of lean manufacturing: what lean thinking has to offer the process industries. *Chemical engineering research and design*, Vol. 83(6), pp. 662-673, 2005.
- [4] Gojković, R., Nestić, S., Lean waste in the manufacturing industry, 5th International scientific conference “Conference on Mechanical Engineering Technologies and Applications” COMETA2020, pp. 561-565, East Sarajevo, 2020.
- [5] Arunagiri, P., Gnanavelbabu, A., Identification of Major Lean Production Waste in Automobile Industries using Weighted Average Method. *Procedia Engineering*, Vol. 97, pp. 2167–2175, 2014.
- [6] Pessôa, M. V. P., Seering, W., Rebentisch, E., Bauch, C., Understanding the Waste Net: A Method for Waste Elimination Prioritization in Product Development. *Advanced Concurrent Engineering*, pp. 233–242, 2009.
- [7] Gnanavelbabu, A., Arunagiri, P., Ranking of MUDA using AHP and Fuzzy AHP algorithm. *Materials Today: Proceedings*, Vol. 5(5), pp. 13406–13412, 2018.
- [8] Amrina, E., Andryan, R., Assessing wastes in rubber production using lean manufacturing: a case study. 6th International Conference on Industrial Engineering and Applications (ICIEA) pp. 328-332, IEEE, 2019.
- [9] Gojković, R., Đurić, G., Tadić, D., Nestić, S., Aleksić, A. Evaluation and Selection of the Quality Methods for Manufacturing Process Reliability Improvement—Intuitionistic Fuzzy Sets and Genetic Algorithm Approach. *Mathematics*, Vol. 9(13), pp. 1531, 2021.
- [10] Pieńkowski, M., Waste measurement techniques for lean companies. *International Journal of Lean Thinking*, Vol. 5(1), pp. 9-24, 2014.
- [11] Holweg, M., The genealogy of lean production. *Journal of Operations Management*, Vol. 25(2), pp. 420–437, 2007.
- [12] McManus, H. L., *Product Development Value Stream Mapping (PDVSM) Manual Release 1.0.*, 2005.
- [13] LERC, Lean Enterprise Research Centre, Cardiff Business School, website: [www.cf.ac.uk/carbs/lom/lerc](http://www.cf.ac.uk/carbs/lom/lerc).
- [14] Ohno, T., *Toyota Production System: Beyond Large-Scale Production*. Portland: Productivity Press, 1988.
- [15] Liker, J., *The Toyota Way: 14 Management Principles from the World’s Greatest Manufacturer*. New York: McGraw-Hill, 2004.

## AIR POLLUTION FROM SOLID PARTICLES, FILTRATION AND FILTERS

Milena Medenica<sup>1</sup>, Miomir Raos<sup>1</sup>, Milan Protić<sup>1</sup>, Milena Mančić<sup>1</sup>

<sup>1</sup>University of Niš, Faculty of Occupational Safety, Niš, Serbia

e-mail: [milena.medenica@znrfak.ni.ac.rs](mailto:milena.medenica@znrfak.ni.ac.rs)

**Abstract:** The problem of air pollution is becoming an increasingly current problem of today's society, which notably influence at the environment and human health in general. Air protection is increasingly emerging as a priority for the entire population, and in recent times it is gaining increasing proportions that require great and special attention in order to take protection measures, especially in large agglomerations. The polluted air is located both in the atmosphere and in the working environment. Air quality is affected by the concentrations of pollutants in the air that occur as a consequence of anthropogenic human impact on the environment. There are a number of methods used to purify polluted air, and one of the most commonly used methods is filtration. The purpose of the filtration process is to remove pollutants from the air which is refined. In this paper, special emphasis is given to the analysis of air purification and filtration techniques, as well as the presentation of filters used to remove solid particles from polluted air.

**Key words:** filtration process, air filtration, filters, air pollution, particulate matter

### INTRODUCTION

The development of technological processes culminated at the end of the 20th century, and they are still developing. With this development, a number of dangers appear, among other things, the problem of air pollution, which is becoming a current problem of today's society, which notably influence to the environment and human health in general. Air protection is increasingly emerging as a priority for the entire population, and in recent times it is gaining increasing proportions that require great and special attention in order to take protection measures, especially in large agglomerations.

The growing problem of air pollution has caused great concern for public health due to its harmful effects. Outdoor air pollution is one of the world's largest health and environmental problems. Any change in the structure of the air is in relation to natural conditions due to the presence of other gases, vapors, particles in concentrations that affect human health or affect the biosphere is considered air pollution. Air pollution is a chemical, particulate matter, or biological agent that modifies the natural characteristics of the atmosphere. Through human action, various substances reach in the air. Emission of pollutants is the direct or indirect release of particles, gases, vapors, aerosols and all other pollutants into the air, water and soil, or represents the level of concentration of pollutants at the place of origin [1].

The worst air quality, observed from the medical point of view, causes a whole range of diseases: a increase number of allergies in humans, worsening of asthma, heart disease, lung cancer and many other diseases. The consequences of air pollution on the human health are from two to three times greater than previously thought. The World Health Organization estimates that 2 million people die from air pollution every year. By destroying ecosystems, crops, and plants, air pollution also affects the global economy and sustainable development [19].

In cities with developed industry and traffic (urban areas), the sources of air pollution it is possible to share into several groups [1]:

- combustion of solid, liquid and gaseous fuels in power plants (including district heating),
- combustion of solid, liquid and gaseous fuels in motor vehicles,
- industrial processes,
- solid waste landfills,
- evaporation of various organic solvents.

Air pollution from anthropogenic sources imposes a significant burden on public health in most developed countries. Particulate matter (PM), which are microscale airborne pollutants, has specifically been recognized as a serious risk factor for premature mortality [4].

The air quality in the industrial process is mostly affected by powdery substances, regardless of their granulate (PM<sub>10</sub>, PM<sub>2.5</sub>, TSP).

Particulate matter (PM) is classified based on particle diameter. Particles larger than 2.5 (µm) are categorized as coarse particles, while those between 0.1 and 2.5 (µm) are fine particles, and those less than 0.1 (µm) are considered ultrafine dust [2]. PM comprises both solid and liquid droplets that originates from sources that include vehicle exhaust, road dust, smokestacks, forest fires, windblown soil, volcanic emissions, and sea spray [3]. Most coarse particles originate from soil or sea salts, while fine particles and ultrafine particles are mainly generated from the combustion of fossil fuels.

When it comes to the choice of filters for the purification of polluted air, an important parameter is the emission of PM<sub>2.5</sub> particles, or their concentration.

When determining the permissible concentrations, that is limit values of pollutant emissions in the industrial process, the type, capacity, age, planned service life of the plant and the fuel used in it, as well as methods, method of measuring pollutant emissions, selection criteria should be taken into account. Measuring points, method of checking the accuracy of measurements (control measurements and calibration), method of processing measurement results, method and deadlines for data submission and the procedure for determining the total annual emission from the combustion plant [20]. Depending on the size of the pollutant particles, and their concentrations, the government prescribes the limit values of permitted concentrations that are transcribed by certain laws.

The Law on Air Protection in the area of Suspended Particles defined two criteria [20]:

- PM<sub>10</sub> is a fraction of suspended particles (particulate matter) that passes through a filter whose requirements are set out in the standard SRPS EN 12341, which establishes a reference method for sampling and measuring the PM<sub>10</sub> fraction, with an efficiency of 50%, capturing particles with an aerodynamic diameter of 10/1000 (mm).
- PM<sub>2.5</sub> is a fraction of suspended particles that passes through a filter whose requirements are set out in the standard SRPS EN 14907 which establishes a reference method for sampling and measuring the PM<sub>2.5</sub> fraction with an efficiency of 50%, capturing particles with an aerodynamic diameter of 2.5/1000 (mm).

The Decree defines the criteria for estimating the concentrations of suspended particles PM<sub>10</sub> and PM<sub>2.5</sub>. Average 24-hour concentration for PM<sub>10</sub> upper limit 35/1000 (g/m<sup>3</sup>), lower limit 25/1000 (g/m<sup>3</sup>). Average annual concentration for PM<sub>2.5</sub> upper limit 17/1000 (g/m<sup>3</sup>), lower limit 12/1000 (g/m<sup>3</sup>).

In order to measure air pollution, it is important to know two regulations: Ordinance relating to emission limit values, method and deadlines for measurement, as well as data recording and Ordinance related to limit values of immission, the way and methods related to immission measurement, determination of measuring points and data recording.

The amount of toxic substances that are in the vicinity of the workplace, so called working atmosphere, that does not cause damage to the health of employees during a number of years of exposure and does not require the application of special measures for protection at work is the Maximum Allowable Concentration (MDK). There are no standardized ways to determine the MDK. The maximum allowable concentration can be divided into three groups [16]: the first group refers to substances with acute toxic effects and they must not be exceeded at all, they are marked with one stars (\*); the second group refers to substances that act intensified during re-exposure and are marked with two stars (\*\*) and the third group refers to carcinogenic substances that are prohibited in any amount, both for contact by any means and ingestion, even in small traces, and are marked with three stars (\*\*\*)

The limit value emission (GVE) represents the level of quantity and concentration of harmful and dangerous substances allowed to the maximum at the place where the source of pollution is located. It is measured at a temperature of 0 (°C) and a pressure of 1013 (mbar) in dry waste gas and is expressed in the forms of mass concentration, mass flow, emission factor and emission degree. The limit value of immission (GVI) represents the highest allowed level of concentration of pollutants in the air. Sampling of gaseous components takes at least 60 minutes, solids 24 hours, while the concentration of SO<sub>2</sub> and soot in the air is determined daily [16].

One of the ways to the air purification is filtration. The purpose of the filtration process is to remove pollutants from the air that is being purified. The outdoor design PM<sub>2.5</sub> concentration is an important parameter for air filters selection [22].

## AIR FILTRATION

Filtration is the process of removing suspended solids from the air. Removal of suspended particles from the air takes place with filters. Air filtration filters are used to remove coarse and fine particles from the air, separating dirt, oil residues, oil vapors and smells from the air. The type of filter for air purification depends on the need and purpose for which the purified air used, as well as on the air production capacity.

When it comes to the industrial process, can be spotted that in most industrial processes, during production, particles accumulate due to abrasive wear during operation, where they become harder than the motherboard. If these particles are not removed by proper filtration, they will return to the production process and cause additional wear. For that reason, it is necessary to determine an adequate way of filtration in order to avoid breakdowns and production downtime.

Depending on the production - technical process and the length of its duration, all filters are divided into two basic groups of performance: Filters with continual cleaning - automatic cleaning of filter bags with compressed air, and Filters with periodic cleaning - mechanical cleaning of filter bags with vibrators.

These filters are purposed for to dust off of industrial facilities and permanent monitoring of the technological process. Filter operation takes place 24/24 h.

When it comes to the filtration of polluted air, it is done through a filter bag whose quality is selected depending on the type of dust and the requirements for the quality of cleaned air. The cleaning of the filter bags takes place by means of pulsed blows of compressed air at a pressure of 6 to 8 bar, and secondary induction of air from the clean part of the filter. The supply of air in the pulses is done by solenoid valves, and the pulse frequency and duration are regulated via an electronic programmer that is delivered as an integral part of the filter. The utilization rate of the filtration surface is 99.5%.

All types of filters are equipped with inertial or centrifugal forces, with the help of which high concentrations of dust are purified, whereby the purification period is extended, which prolongs the life of filter bags. Replacement of old filter bags is done through a clean part of the filter, avoiding contact with the dust chamber.

The filtration itself depends on the filter capacity, which depends on the unit load  $q$  ( $\text{m}^3/\text{m}^2\text{h}$ ). Depending on the fineness of the dust, structure, degree of humidity and inlet concentration in the filter, the parameter  $q$  ranges from 70 to 180 ( $\text{m}^3/\text{m}^2\text{h}$ ). When it comes to parameter values and dust concentrations, the following recommendations can be adopted:

- Values  $q = 70 - 100$  ( $\text{m}^3/\text{m}^2\text{h}$ ), refer to input dust concentrations over  $80$  ( $\text{g}/\text{m}^3$ ) of dusty air (dust with increased humidity and low density dust).
- Value  $q = 100 - 120$  ( $\text{m}^3/\text{m}^2\text{h}$ ), refers to input dust concentrations of  $50-80$  ( $\text{g}/\text{m}^3$ ) of dusty air (dry non-stick dust with a density of  $1.5-3.2$   $\text{g}/\text{cm}$ ). This concentration is considered normal and is most often recommended.
- Value  $q = 150 - 180$  ( $\text{m}^3/\text{m}^2\text{h}$ ), refers to inlet dust concentrations below  $20$  ( $\text{g}/\text{m}^3$ ) of dusty air, but with built-in cyclones type ZC100 in front of the filter plant.

In Fig. 1, a schematic representation of air filtration is given:

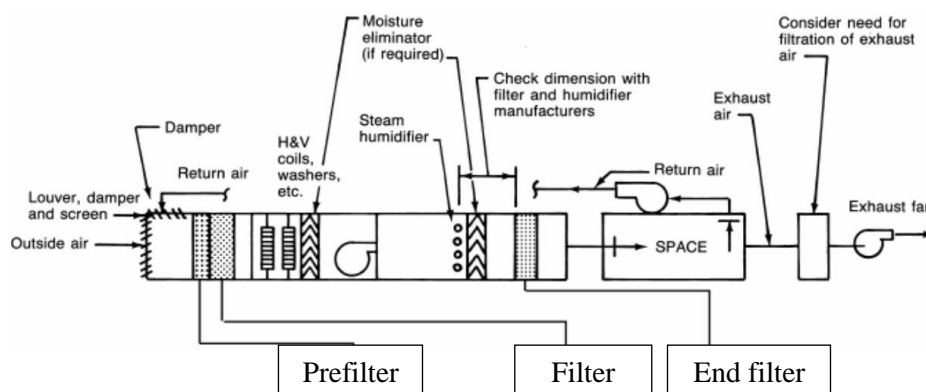


Fig. 1. Schematic representation of air filtration through the system [22].

## Types of filters

The problem of air pollution is a big problem for public health due to the harmful effects it causes. As a result, new air filtration technologies have been developed to improve filtration efficiency.

Air purification in modern environmental conditions is very important. When it comes to the industrial process, air purification devices play an important role in air purification. For this reason, special attention should be paid to which type of filter should be chosen depending on the production process. Electrostatic types of filter devices are most often used for air purification. The electrostatic method is considered to be the most effective method for removing particles of dust, soot and other pollutants in the air. These filters are used in the industrial segment, where substances with a high concentration of toxic gases can accumulate.

Filters for air purification in industrial process:

Electrostatic filters - These filters are considered one of the most effective for removing dust, soot and other polluting particles in the air. They are used in industrial processes, but they are also used a lot for home use. They consist of a metal plate and a filter located between them. An electric field is formed between the filter and the metal plate, which is converted into an ionized current. When polluted air enters, harmful substances get charged and an electric field is created, whereby the polluting particles approach the metal where they stick and stay there, and in that way the polluting particles are separated. Fig. 2 shows a schematic representation of the operation of electrostatic filters:

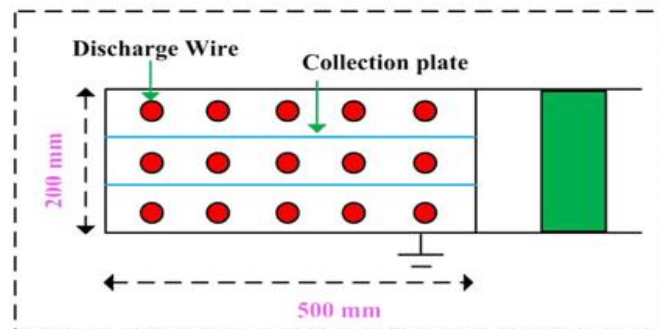


Fig. 2. Schematic representation of the electrostatic filters [14].

HEPA filters - They are considered very effective in air purification. Their removal efficiency is at least 99.97% of 0.3 micron particles. They contain fibrous raw materials in the form of an accordion, and they have a great power to retain dust. They are mostly used to filter airborne particles such as smoke, fine dust, mites and other airborne allergens. The problem arises, when dust of a larger fraction (coarse dust) occurs, the device becomes clogged and for that reason it is necessary to install a device for separating larger particles in front of the device. Fig. 3 shows a schematic representation of the operation of HEPA filters:

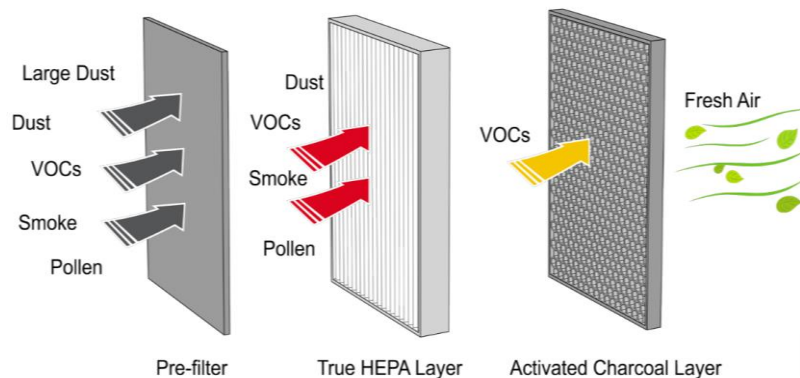
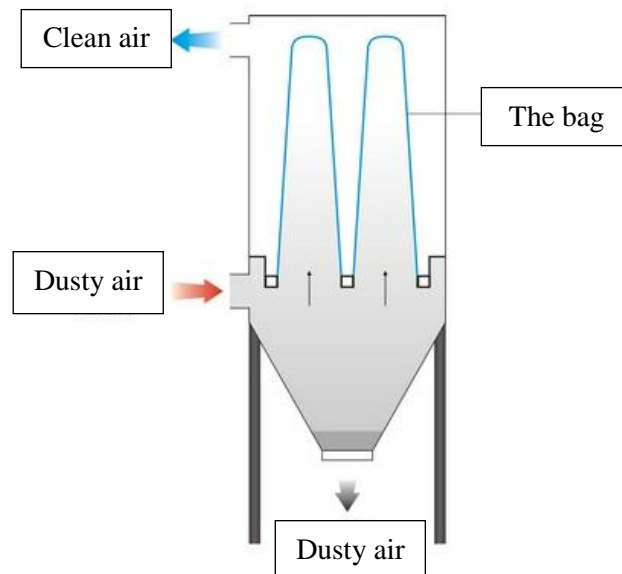


Fig. 3. Schematic of HEPA filter operation [9].

Bag filters - They have high purification efficiency and are they are used in all technological processes of the industry. They have the ability to remove particles ranging in size from submicron to several

hundred microns in diameter, which is why their purification efficiency is 99.99%. They can be made of different materials depending on the need for which the filter bags are made. As for their operation, polluted air enters through an opening at the bottom of the filter housing, hits the protective plate and part of the polluted air falls into the bunker. With the help of centrifugal force, the coarse particles are separated before entering the filter, then the air passes through the filter bag and the air is filtered. The collected particles are taken to the collection bunker, and the cleaned air passes through the outlet channel, and through the fan into the atmosphere, while the polluting particles from the collection bunker are taken to the place where the dust is reloading. Fig. 4 shows a schematic representation of the operation of the bag filter:



**Fig. 4.** Schematic representation of the operation of the bag filter [6].

Jet-pulse filters - Also called jet dust collectors. They are most often used to remove dry particles, and to purify the air. They have high efficiency of filtration. They consist of a built-in cyclone and bag filters that serve to separate dust particles. In the pulse-jet bag filters, the bags are cleaned by injecting compressed gas. The bag filters range from 5 (m<sup>2</sup>) to 2.000 (m<sup>2</sup>) and are available in various configurations such as rectangular, square or cylindrical blockhouse. In a pulsed jet system, dust collects on the outer surface of the filter, causing the pressure to drop, then the controller to activate, and under the influence of gravity, the dust from the filter falls into the tank for removal. Fig. 5 shows a schematic representation of the operation of the Jet-pulse filter:



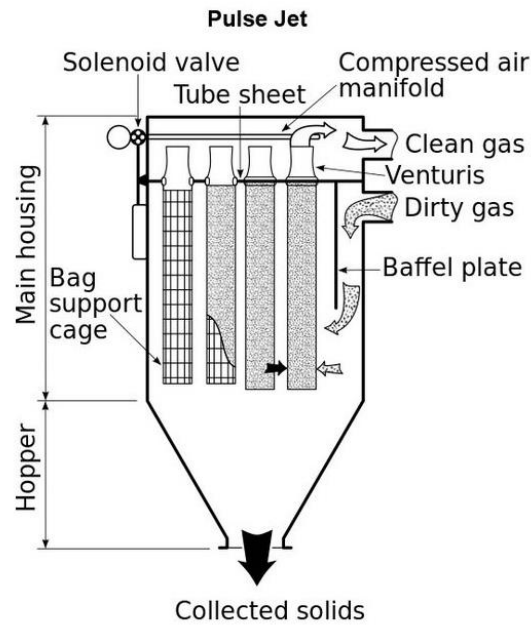


Fig. 5. Schematic of Jet-pulse filter operation [8].

### FILTER EFFICIENCY EQUATION FOR PM

Fig. 6 shows the channel through which fluid (gas, air) flows bounded on only two sides by flat plates located on mutual distance  $d$ . The channel is  $L$  long and wide  $h$ . Fluid flows through channel at constant speed  $v$ . Charged particles are deposited at channel walls, with speed  $w$ , due to attractive electrostatic forces.

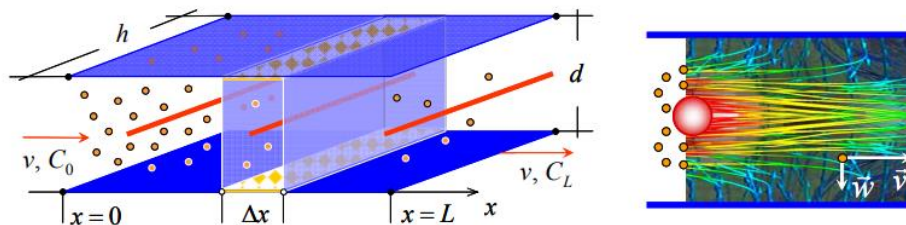


Fig.6. Particle deposition and collection efficiency [23].

The derivation of the equation for particle collection efficiency is based on several assumptions:

- In any cross section, the particle concentration, is uniform;
- Fluid flow is laminar and takes place at a constant speed;
- The speed of particle motion is constant;
- There is no re-entry of already collected particles into to the innerspace [23].

The equation given in the text below is known as Deutsch-Anderson equation:

$$\eta = \frac{C_o - C_L}{C_o} = 1 - \frac{C_L}{C_o} = 1 - e^{-\frac{wS}{Q}} \quad (1)$$

Where:  $C_o$  is concentration of PM in canal inlet and  $C_L$  is concentration of PM in canal outlet.

$$C_L = C_o e^{-\frac{wS}{Q}} \quad (2)$$

$$S = 2hL, Q = vhd \quad (3)$$

In the Table 1, is given the first modification of this equation known as the Matts-Ohnfeldt equation (Sigward Matts, Per-Olaf Ohnfeldt). Another attempt to improve the Deutsch-Anderson equation is known as as White's correction (Harry J. White), whose goal was simplification of the expression appears the average velocity of the particles which in principle is no different from the speed used by its predecessors.

**Table 1.** First and second modification of the Deutsch-Anderson equation [23].

Deutsch-Anderson	Matts - Ohnfeldt	White
$\eta = 1 - e^{-\frac{wS}{Q}}$	$\eta = 1 - e^{-w_k(\frac{S}{Q})^k}$	$\eta = 1 - e^{-\frac{w_e S}{Q}}$

## CONCLUSION

Air purification in modern environmental conditions is very important. When it comes to the industrial process, air purification devices play an important role in air purification. As a result, new air filtration technologies have been developed to improve filtration efficiency itself. In order to purify the air, and thus protect health, special attention should be paid to which type of filter should be chosen depending on the production process.

The technical solution of a filter plant depends primarily on the pollutant that is dominant in the technological process, and then on the flow of air that is filtered, the desired outlet purity of air, etc.

The problem that arises in the exploitation of the filter plant in technological processes in which the flow of "dirty" air is large, and in which large amounts of powdery substances - suspended particles are generated, is that a large amount of powdery substances quickly stick to the filter bags. to perform the function of purification, whereby there is an increase in resistance to air movement and congestion of the filter itself.

The best solution for regulating this problem proved to be the previously mentioned filters: electrostatic filters, bag filters, HEPA filters and jet - pulse filters, which showed that they have the highest efficiency in the technological process for purifying polluted air and air quality management.

**Acknowledgement:** This paper is a result of a research supported by the Ministry of Education, Science and Technological Development of the Republic of Serbia according to contract no. 451- 03-9 / 2021-14 / 200148.

## REFERENCES

- [1] Alonso-Fariñas, B., Lupion, M., Rodriguez-Galan, M., Martinez-Fernandez, J.: New candle prototype for hot gas filtration industrial applications, Fuel, Vol. 114, pp. 120-127, 2013.
- [2] Çankaya, N., Özcan, M.: Performance optimization and improvement of dust laden air by dynamic control method for jet pulsed filters, Advanced Powder Technology, Vol. 30, Issue 7, pp. 1366-1377, 2019.
- [3] Furumoto, K., Narita, T., Fukasawa, T., Ishigami, T., Kuo, H. P., Huang, A. N., Fukui, K.: Influence of pulse-jet cleaning interval on performance of compact dust collector with pleated filter, Separation and Purification Technology, Vol. 279, 2021.
- [4] Han, S., Kim, J., Ko, S.H.: Advances in airfiltration technologies: structure-based andinteraction-based approaches, Materials Today Advances journal, Vol. 9, 2021.
- [5] Heidenreich, S., Hot gas filtration – A review, Fuel, Vol. 104, pp. 83-94, 2013.

- [6] Chemistry Dictionary, Available at: <https://glossary.periodni.com/glosar.php?hr=vre%C4%87asti+filar>
- [7] High flow, high strength industrial HEPA filters, *Filtration + Separation*, Volume 58, Issue 2, pp. 4, 2021.
- [8] Indro filter workshop, Available at: <https://filterworkshop.com/pulse-jet-baghouse-filter-bags-sleeves-p00706p1.html>
- [9] Roma Living Styles, Available at: <https://www.aromalivingstyles.com/learning-center/hepa-charcoal-tech.html>
- [10] Saravanan, S., Brindha, D.: Global stability of centrifugal filtration convection, *Journal of Mathematical Analysis and Applications*, Vol. 367, Issue 1, pp. 116-128, 2010.
- [11] Shendell, D.G.: Community Outdoor Air Quality: Sources, Exposure Agents and Health Outcomes, *Encyclopedia of Environmental Health (Second Edition)*, pp. 713-727, 2019.
- [12] Smiles, D.E.: Centrifugal filtration of particulate systems, *Chemical Engineering Science*, Vol. 54, Issue 2, pp. 215-224, 1999.
- [13] Sutherland, K.: Filtration overview: A closer look at depth filtration, *Filtration & Separation*, Vol. 45, Issue 8, pp. 25-28, 2008.
- [14] Svarovsky, L.: Centrifugal filtration, *Solid-Liquid Separation (Fourth Edition)*, pp. 432-441, 2001.
- [15] Svarovsky, L.: Vacuum filtration, *Solid-Liquid Separation (Fourth Edition)*, pp. 409-431, 2001.
- [16] Decree on limit values for emissions of pollutants into the air from combustion plants ("Official Gazette of RS", No. 6/2016 and 67/2021)
- [17] Wang, F. L., He, Y. L., Tang, S. Z., Kulacki, F. A., Tao, Y. B.: Particle filtration characteristics of typical packing granular filters used in hot gas clean-up, *Fuel*, Vol. 234, pp. 901-915, 2018.
- [18] Wang, F. L., He, Y. L., Tang, S. Z., Kulacki, F. A., Tao, Y. B.: Real-time particle filtration of granular filters for hot gas clean-up, *Fuel*, Vol. 237, pp. 308-319, 2019.
- [19] WHO's UrbanAmbient Air Pollution database - Update, 2016
- [20] Law on Air Protection ("Official Gazette of RS", No. 36/2009, 10/2013 and 26/2021 - other law)
- [21] Zeitsch, K.: Centrifugal Filtration, *Solid-Liquid Separation (Third Edition)*, pp. 476-532, 1990.
- [22] Zhang, X., Fan, Y., Zhang, J., Wang, H., Wei, S.: Research on outdoor design PM<sub>2.5</sub> concentration for fresh air filtration systems based on mathematical inductions, *Journal of Building Engineering*, Vol. 34, 2021.
- [23] Radić, M. D., Petković, M.D: Electrostatic precipitators, Niš, 2013.

## DECOMPOSITION OF SELECTED PHARMACEUTICAL MICROPOLLUTANTS BY NEWLY SYNTHESIZED NANOMATERIAL

Mladenka Novaković<sup>1</sup>, Dragana Štrbac<sup>1</sup>, Maja Petrović<sup>1</sup>, Boris Obrovski<sup>1</sup>, Goran Štrbac<sup>2</sup>, Ivana Mihajlović<sup>1</sup>

<sup>1</sup>University of Novi Sad, Faculty of Technical Sciences, Novi Sad, Serbia

<sup>2</sup>University of Novi Sad, Faculty of Sciences, Novi Sad, Serbia

e-mail: [mladenkanovakovic@uns.ac.rs](mailto:mladenkanovakovic@uns.ac.rs)

**Abstract:** The widespread usage of pharmaceutical components causes their constant emission into the aquatic ecosystem, which leads to the phenomenon of pseudo-persistence, i.e., indicates that the rate of input of emerging pollutant into the environment is significantly higher than the rate of degradation. The low percentage of removal of pharmaceutical components using conventional treatments requires the application of more efficient modern technologies, such as advanced oxidation techniques. In order to examine the potential suitable method for removal of pharmaceutical residues, photocatalytic treatment with newly synthesized nanopowder mixture was performed on laboratory scale. The examined photocatalyst consist of binary metal oxide system, zinc oxide and indium oxide (ZnO/In<sub>2</sub>O<sub>3</sub>). The competitive photocatalytic system included degradation of pharmaceuticals such as ketoprofen, diclofenac, naproxen and ibuprofen.

**Key words:** wastewater, pharmaceuticals, nanomaterials, photocatalysis

### INTRODUCTION

Pharmaceutical compounds, as well as their biologically active metabolites, continuously reach the aquatic environment in various ways, primarily through untreated or inadequately treated wastewater. After usage, pharmaceuticals undergo transformation reactions to metabolites that are often more polar than the parent compounds. Pharmaceutical residues are detected at very low concentration levels in different environmental media [1].

The fate and persistence of excreted pharmaceuticals and metabolites in the aquatic environment depends on the physicochemical properties of the pharmaceuticals and the chemical and biological characteristics of the recipients. The most important chemical properties of pharmaceutical components are acid dissociation constant (pKa), octanol-water partition coefficient (logKow), octanol-water ratio (logDow), organic carbon-water partition coefficient (log Koc) and solubility. These characteristics show the ionization state of the components, hydrophobicity and partition in water, solids, sediment and biological medium [2].

Evaluation of the effect of individual pharmaceutical components is very complex in the presence of other pharmaceutical compounds. Organic contaminants are always present in the mixture in aquatic recipients. The complex nature and dynamic behavior of pharmaceuticals pose a potential effect to aquatic organisms. Studies have shown that a mixture of pharmaceuticals in concentrations quantified in the environment (in ng L<sup>-1</sup>) causes a reduction in cells or a decrease in cell proliferation in vitro [3]. Pharmaceutically active components, due to their persistence in the aquatic medium, can seriously affect microorganisms and other aquatic organisms [4].

Although research has shown that the acute toxicity of pharmaceuticals in water bodies is not significant due to their low concentration, but the chronic toxicity of these micropollutants may affect non-target species in the future. Pharmaceutical residues that are not sensitive to biological degradation in the environment can accumulate or affect aquatic organisms over a long period of time and thus cause side effects on the functioning of the natural and aquatic ecosystem [5].

A special stream of pharmaceuticals in environment represents expired pharmaceuticals. Such pharmaceuticals are disposed on landfills and can reach groundwater due to soil leaching. Pharmaceutical residues could accumulate in sewage sludge, which leads to their emission into the aquatic environment if the sludge is used as agricultural fertilizer. Contamination of groundwater with pharmaceutical micropollutants is also possible by irrigating arable land, given that some pharmaceuticals are not removed by natural processes such as sorption and degradation in the soil.

Advances in the development of analytical methods for the detection of organic compounds at low concentration levels have contributed to the identification of non-steroidal anti-inflammatory drugs (NSAIDs) in drinking water as well. The presence of this group of pharmaceutical components in drinking water is assumed to be caused by soil leaching and through effluents from wastewater treatment plants. In Spain, the average concentrations detected in drinking water for naproxen, ibuprofen and diclofenac were 11, 39 and 18 ng L<sup>-1</sup>, respectively [6].

There are no established regulations that define the maximum allowable concentrations for the discharge of pharmaceuticals into aquatic matrices, so the efficiency of the wastewater treatment plant is estimated as the percentage of removal of pollutants at the inlet and outlet of the plant. It is necessary to determine the final concentrations in the effluent of the plant and to compare the predicted no effect concentration (PNEC) with the concentrations of pollutants quantified in the recipients [7].

Biological treatments require a large operating space and the application of chemicals that are toxic. Also, it has less flexibility in design and operability. Although many organic pollutants are degraded in this way, many other pollutants are resistant to biodegradation due to their complex chemical structure and origin. On the other hand, chemical methods involve the application of large amounts of chemicals and production of sludge that requires additional treatment [8].

Various physical methods such as processes based on membrane filtration (nanofiltration, reverse osmosis, electrodialysis) and adsorption techniques are used worldwide. The most important disadvantage of membrane processes is their duration and the problem of periodic membrane changes, as well as the energy consumption used to achieve high pressures of water passing through membranes. These costs must be included in any economic analysis [9].

Advanced oxidation processes (AOPs) represent treatments which are based on in-situ generation of powerful oxidants which have ability to decompose various range of resistant organic microcontaminants and transforming them into less toxic products. The most reactive oxidizing agent represent hydroxyl radicals (OH<sup>•</sup>) which distinguish non-selective nature. Zinc oxide is a semiconductor with favorable electrical, mechanical, and optical properties such as titanium dioxide TiO<sub>2</sub> [10]. Like titanium dioxide, zinc oxide does not possess antibacterial properties, but shows good photocatalytic activity [11].

The main objective of this study was to investigate photocatalytic performance of newly developed nanomaterial in degradation of non-steroidal anti-inflammatory pharmaceuticals (ketoprofen, naproxen, diclofenac and ibuprofen) in water media.

## MATERIAL AND METHODS

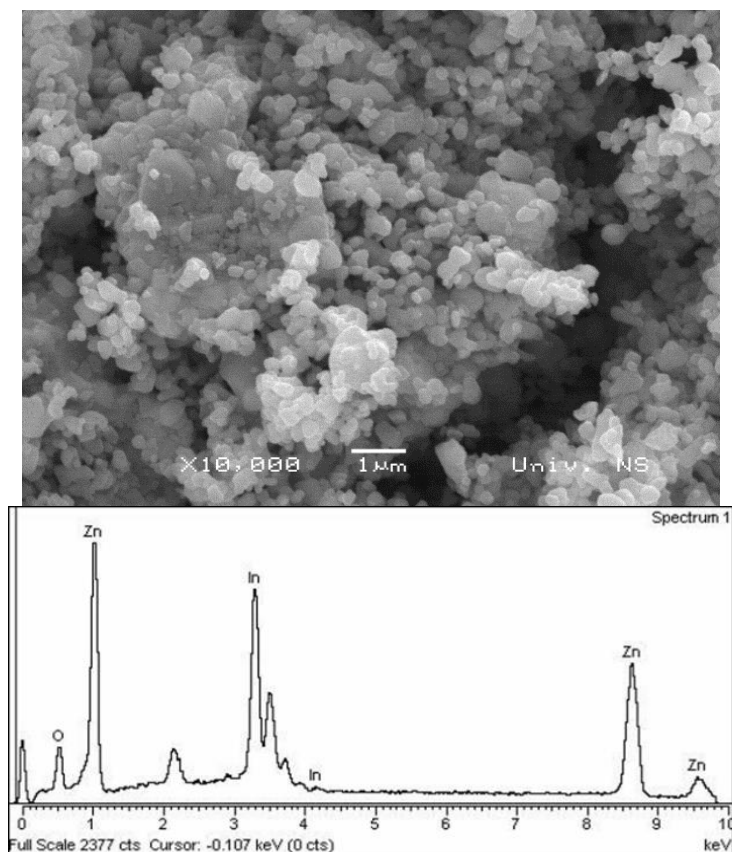
Photocatalytic decomposition of NSAIDs was performed on laboratory scale by application of binary nanomaterial mixture zinc oxide and indium oxide (ZnO/In<sub>2</sub>O<sub>3</sub>). The principle of synthesis of nano powder mixture was based on mechanochemical solid-state method. The molar ratio of analyzed metal oxide was 2:1 [12]. The treatment time of photocatalysis was one hour. Samples were taken at different time periods and filtered through 0,45 μm membrane filters. Filtered aliquots were transferred in 1 mL HPLC vials. Influence of nanomaterial concentration was analyzed in range of 0,10 – 0,60 mg mL<sup>-1</sup>.

Detection of NSAID and their formed transformation products were analyzed by HPLC DAD system (Agilent 1260, USA). The method consists of binary system of mobile phase (A: acetonitrile (ACN) and B: 50 mM potassium dihydrogen phosphate (KH<sub>2</sub>PO<sub>4</sub>) in ultrapure water) was used. The flow of the mobile phases was 1 mL min<sup>-1</sup> and the volume of the injected sample was 20 μL. The duration of the analysis was 10 minutes. The retention times for ketoprofen, naproxen, diclofenac, and ibuprofen were 3,42 min; 3,86 min; 6,17 min and 8,89 min, respectively.

The morphology and microstructure of the analyzed nanopowder were determined using scanning electron microscopy (manufacturer SEM-JEOL JSM 6460LV).

## RESULTS AND DISCUSSION

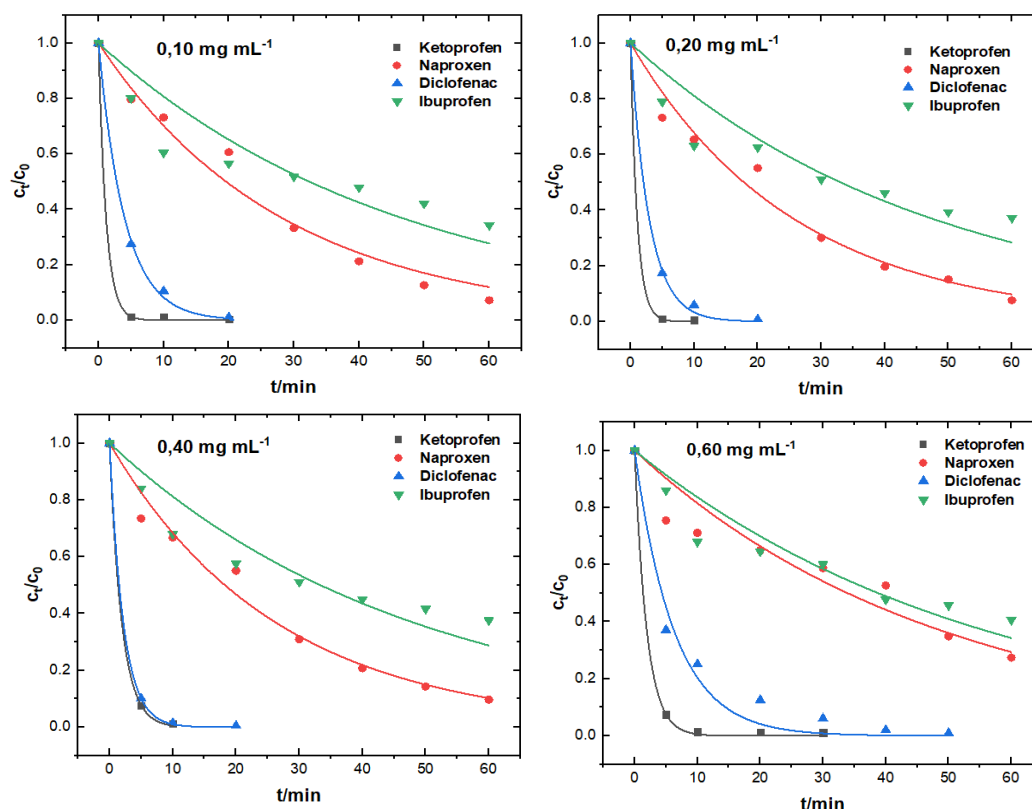
Results of physical characterization of nanopowder mixture ZnO/In<sub>2</sub>O<sub>3</sub> are shown on Figure 1. SEM images indicate that the particles of the newly synthesized mixtures are spherical in shape with an average particle size of ~ 100 nm.



**Fig. 1.** SEM and EDX image of ZnO/In<sub>2</sub>O<sub>3</sub> [13]

Figure 2. shows the exponential change in the concentration of selected pharmaceutical compounds using different concentrations of ZnO/In<sub>2</sub>O<sub>3</sub> nanostructured material in competitive systems. Based on the presented graphs, it can be noticed that the change in the value of the concentration of nanostructured nanomaterial from 0,10 to 0,40 mg mL<sup>-1</sup> did not indicate a significant difference in the case of ketoprofen and diclofenac. A time period of 20 minutes was sufficient for complete degradation. With a further increase in concentration to 0,60 mg mL<sup>-1</sup>, the time period for complete decomposition of ketoprofen and diclofenac was 40 and 60 minutes, respectively.

The maximum analyzed concentration of 0,60 mg mL<sup>-1</sup> was not sufficient for complete transformation of naproxen and ibuprofen, while a similar trend in the exponential decrease in concentration was observed in the range of 0,10 to 0,40 mg mL<sup>-1</sup>. One possible explanation for this behavior is that the optimal concentration of nanomaterials was 0,40 mg mL<sup>-1</sup>, after which there was a decrease in the degradation efficiency. The increase in the concentration of the implemented nanomaterial is not directly related to the degradation efficiency. The most persistent pharmaceutical in competitive system was ibuprofen, which indicates that one-hour period of treatment is not sufficient for its complete degradation and transformation into photocatalytic intermediates.



**Fig. 2.** Influence of initial concentration of  $\text{ZnO}/\text{In}_2\text{O}_3$  on degradation of NSAIDs mixture (initial concentration of NSAIDs –  $c_0(\text{mg L}^{-1})$ ; concentration of NSAIDs at different time intervals -  $c_t (\text{mg L}^{-1})$ ; irradiation time –  $t(\text{min})$ )

## CONCLUSION

Pharmaceutical active residues represent one of most dominant group of organic micropollutants which are continuously introduced into different environmental routes due to the inevitable daily use for human health and other purposes. Configuration of current wastewater treatment plants is not suitable for efficient removal of these type of emerging pollutants.

The most intensive degradation was achieved for ketoprofen and diclofenac. Based on the obtained results it can be concluded that ibuprofen is the most resistant pharmaceutical whose complete transformation into its intermediates was not achieved in the analyzed process time. Further studies will be based on extension of treatment time in order to investigate if ibuprofen degradation can be improved. According to obtained results, it can be concluded that newly synthesized photocatalyst,  $\text{ZnO}/\text{In}_2\text{O}_3$  has great potential in decomposing these group of pharmaceutical compounds.

## ACKNOWLEDGEMENT

The presented research is partly financed within a project of the Government of Vojvodina “Synthesis and application of new nanostructured materials for the degradation of organic pollutants from municipal landfill leachate in Vojvodina“ 142-451- 2387/2018-01/01, the Ministry of Education, Science and Technological Development through the project no. 451-03-68/2020-14/200156: “Innovative scientific and artistic research from the FTS domain”, the Bilateral project funded by the Ministry of Education, Science and Technological Development (contract no. 337-00-107/2019-09/16) and Slovak Research and Development Agency under contract SK-SRB-18-0020.

## REFERENCES

- [1] Caban, M., Stepnowski, P., How to decrease pharmaceuticals in the environment? A review, *Environmental Chemistry Letters*, Vol.19, pp. 3115–3138, 2021.
- [2] Pereira, A., Silva, L., Laranjeiro, C., Lino, C., Pena, A., Selected pharmaceuticals in different aquatic compartments: Part I—Source, fate and occurrence, *Molecules*, Vol.25, pp. 1-33, 2020.
- [3] Pomati, F., Castiglioni, S., Zuccato, E., Fanelli, R., Vigetti, D., Rossetti, C., Calamari, D., Effects of a complex mixture of therapeutic drugs at environmental levels on human embryonic cells, *Environmental Science and Technology*, Vol.40, pp. 2442–2447, 2006.
- [4] Bhatia, V., Malekshoar, G., Dhir, A., Ray, A.K., Enhanced photocatalytic degradation of atenolol using graphene TiO<sub>2</sub> composite, *Journal of Photochemistry and Photobiology A: Chemistry*, Vol.332, pp. 182–187, 2017.
- [5] Kümmerer, K., The presence of pharmaceuticals in the environment due to human use – present knowledge and future challenges, *Journal of Environmental Management*, Vol.90, pp. 2354–2366, 2009.
- [6] Mlunguza, N.Y., Ncube, S., Nokwethemba Mahlambi, P., Chimuka, L., Madikizela, L.M., Adsorbents and removal strategies of non-steroidal anti-inflammatory drugs from contaminated water bodies, *Journal of Environmental Chemical Engineering*, Vol.7, pp. 103142, 2019.
- [7] de Jesus Gaffney, V., Almeida, C.M.M., Rodrigues, A., Ferreira, E., Benoliel, M.J., Cardoso, V.V., Occurrence of pharmaceuticals in a water supply system and related human health risk assessment, *Water Research*, Vol.72, pp. 199–208, 2015.
- [8] Oller, I., Malato, S., Sánchez-Pérez, J.A., 2011. Combination of Advanced Oxidation Processes and biological treatments for wastewater decontamination-A review, *Science of Total Environment*, Vol. 409, pp. 4141–4166, 2011.
- [9] Luo, Y., Guo, W., Ngo, H.H., Nghiem, L.D., Hai, F.I., Zhang, J., Liang, S., Wang, X.C., A review on the occurrence of micropollutants in the aquatic environment and their fate and removal during wastewater treatment, *Science of Total Environment*, Vol. 473-474, pp. 619-641, 2014.
- [10] Gharoy Ahangar, E., Abbaspour-Fard, M.H., Shahtahmassebi, N., Khojastehpour, M., Maddahi, P., 2015. Preparation and Characterization of PVA/ZnO Nanocomposite, *Journal of Food Processing and Preservation*, Vol. 39, pp. 1442–1451, 2015.
- [11] Al-Fori, M., Dobretsov, S., Myint, M.T.Z., Dutta, J., Antifouling properties of zinc oxide nanorod coatings, *Biofouling* Vol. 30, pp. 871–882, 2014.
- [12] Ivetić, T.B., Finčur, N.L., Abramović, B.F., Dimitrievska, M., Štrbac, G.R., Čajko, K.O., Miljević, B.B., Đaćanin, L.R., Lukić-Petrović, S.R., Environmentally friendly photoactive heterojunction zinc tin oxide nanoparticles, *Ceramics International*, Vol.42, pp. 3575–3583, 2016.
- [13] Novakovic, M., Strbac, G., Petrovic, M., Strbac, D., Mihajlovic, I., Decomposition of pharmaceutical micropollutant–diclofenac by photocatalytic nanopowder mixtures in aqueous media: effect of optimization parameters, identification of intermediates and economic considerations, *Journal of Environmental Science and Health, Part A Toxic/Hazardous Substances and Environmental Engineering*, Vol. 55, pp. 483-497, 2020.



## ADSORPTION KINETICS OF 3-(4-METHYLBENZYLIDENE) CAMPHOR ON MICROPLASTICS IN WATER

Maja Vujić<sup>1</sup>, Aleksandra Tubić<sup>1\*</sup>, Vasiljević Sanja<sup>1</sup>, Jelena Molnar Jazić<sup>1</sup>, Tajana Simetić<sup>1</sup>, Malcolm Watson<sup>1</sup>, Jasmina Agbaba<sup>1</sup>

<sup>1</sup>University of Novi Sad, Faculty of Sciences, Department of Chemistry, Biochemistry and Environmental Protection, Trg Dositeja Obradovića 3, 21000 Novi Sad, Republic of Serbia  
e-mail: [aleksandra.tubic@dh.uns.ac.rs](mailto:aleksandra.tubic@dh.uns.ac.rs)

**Abstract:** Microplastics (MPs), plastic particles smaller than 5 mm, are ubiquitous contaminants of growing concern. Once released in the environment, microplastics interact with multiple chemicals, organic or inorganic contaminants. Some contaminants have an affinity for microplastics, and thus it becomes vector of hazardous chemicals. In this study we were focused on investigating the adsorption kinetics of 3-(4-methylbenzylidene) camphor (4-MBC) on biodegradable and non-degradable microplastics. The adsorption experiments were conducted in a batch mode, in laboratory conditions. The attained results indicated that the highest adsorption rate was determined for adsorption of 4-MBC on polyethylene terephthalate (PET) and the lowest on polylactic acid (PLA), 11.5 µg/g and 3.52 µg/g, respectively. The obtained data for adsorption of 4-MBC on commercially available granulated microplastics were fitted well by pseudo-second-order kinetic model, indicating that the main adsorption mechanism could be chemisorption. On the other hand, the results of kinetic study for adsorption of 4-MBC on PLA indicated that multilayer adsorption occurs on surface of this microplastic. Obtained results indicate that MPs can be one of transport paths for selected ultraviolet (UV) filter through the environment and therefore all water bodies.

**Key words:** organic pollutants, UV filters, 4-MBC, microplastics, kinetic, adsorption

### INTRODUCTION

Since their development, plastics have become an essential product in modern society due to their versatility, durability, strength, and lightweight. The widespread use and incorrect disposal of plastic items resulted in worldwide pollution of terrestrial and aquatic environments [1]. Their persistence, durability, and massive production have turned plastics into one of the major environmental challenges [2].

Microplastics (MPs), plastic particles smaller than 5mm in size, gained increasing attention since they were first described by Thompson et al. (2004) [3]. They are ubiquitous in the environment, being found in marine sediments, marine and continental waters, terrestrial and agricultural environments [4–6]. It is known that MPs tend to interact with a variety of chemicals, organic and inorganic pollutants, in the environment. Among the organic pollutants, that is known to interact with MPs compounds are polycyclic aromatic hydrocarbons (PAHs), polychlorinated biphenyls (PCBs), pesticides, and pharmaceuticals are generally found [7–13]. The presence of both pollutants: MPs and organic residues in various environmental compartments is an issue of increasing concern. Scientific interest in this topic originated at the beginning of the 21<sup>st</sup> century, making the presence of microplastic particles in the environment a relatively new and ubiquitous area of research [14].

Ultraviolet (UV) filters are considered to have unique photochemical properties and are the key ingredients in sunscreens, cosmetics and other personal care products to protect human skin from direct exposure to UV radiation. Although UV filters decrease the contact opportunities between human skin and UV light, thereby reducing the harmful effects of UV radiation, the widespread use of UV filters results in their pervasiveness in various water matrices and pose environmental risks.

3-(4-methylbenzylidene) camphor (4-MBC), one of the most commonly used organic UV filters, is a camphor derivative that efficiently absorbs UV-B radiation [15]. Several studies have reported the toxicological and adverse effects of 4-MBC. It has been noted that 4-MBC exhibit estrogenic, antiestrogenic, androgenic and antiandrogenic activities. It affects the growth and multiplication of aquatic organisms, and additionally, 4-MBC has been identified as an endocrine disruptor [15,16]. 4-MBC follow two major pathways to enter the environment: direct input in swimming pools, rivers and oceans from human activities through wash off from skin and clothing during recreational activities,

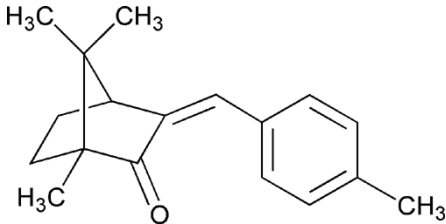
and indirect entry through industrial discharges, wastewater effluents, runoffs and domestic uses. Due to the chemical stability and poor biodegradability of 4-MBC, multiple studies have reported that 4-MBC residues are present in aquatic environments around the world [17,18].

The objective of this study was to determine adsorption equilibrium and kinetic parameters of 4-MBC on four type of MP particles, in order to clarify the possible interaction mechanisms between selected UV filter and MPs.

## MATERIAL AND METHODS

The adsorption kinetic models were applied to determine the relationship between adsorption time and adsorption capacity for 4-MBC adsorption on MPs. Physico-chemical characteristics of 4-MBC are shown in Table 1. Based on the literature review, the behavior of organic pollutants in the presence of microplastics in water significantly depends on their physico-chemical properties [19–21]. Due to that, in this study, all selected organic pollutants were chosen by its relevance to the environment and the differences in their different physico-chemical properties.

**Table 1.** Physico-chemical properties of 3-(4-methylbenzylidene) camphor [17]

Structure	
Molecular weight (g/mol)	254,37
Log K <sub>ow</sub>	4,95
Water solubility (g/L)	5,1 x 10 <sup>-3</sup>

Three types of commercially available microplastics were used, granulated polyethylene (PEg), polyethylene tetraphthalate (PET) and polypropylene (PP) manufactured by Sigma Aldrich. In this study, polylactic acid (PLA, Sigma Aldrich) was also investigated as a representative of bioplastic materials. The size of the granulated types of selected microplastics (PEg, PET, PP and PLA) was provided by the supplier, and it was 3 mm [13,22,23]. 4-MBC' stock solutions with concentrations of 1 mg/mL were prepared in methanol solution.

Hexane and methanol were purchased from J. T. Baker (for organic residue analysis). CaCl<sub>2</sub> (Sigma-Aldrich), NaHCO<sub>3</sub> (Sigma-Aldrich) and MgSO<sub>4</sub>·7H<sub>2</sub>O (Sigma-Aldrich) were used for preparation of the synthetic watermatrix, while HNO<sub>3</sub> (Fluka) and NaOH (Sigma-Aldrich) were used to adjust the pH value of the water. All the reagents were analytical grade without further purification.

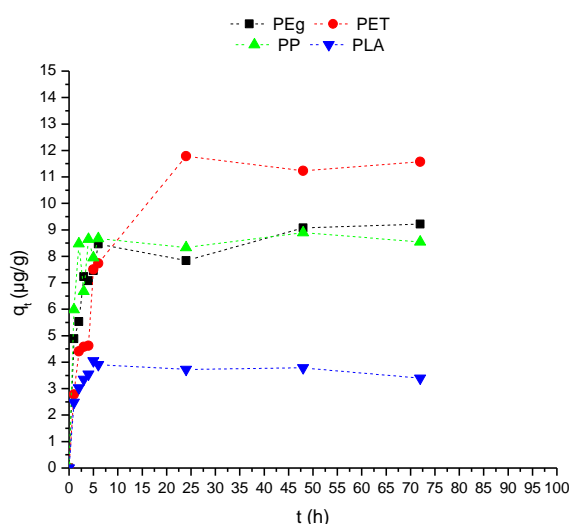
Sorption experiments of adsorption kinetics of 4-MBC on various types of MPs were conducted using a batch equilibrium method in laboratory conditions. The volume of the water solution was 60 mL for selected UV filter, 4-MBC, and the initial concentration of each compound was 10 µg/L. The mass of granulated materials (PEg, PET, PP and PLA) was 40 mg. Complete suspension mixing in the experiments was ensured by using a digital mixer (IKA® Orbital shaker KS 501 Digital), with speed of 150 rpm, at room temperature of 25 °C. All samples were prepared in duplicate. The pH value was 7.23 ± 0.06. After defined time periods (1, 2, 3, 4, 5, 6, 24, 48, 72 and 96 h), MPs particles were removed and the water samples were prepared for GC/MS analysis (Agilent 7890A/5975C). The Lagergren pseudo-first order kinetic, pseudo second-order kinetic, Elovich and Weber-Morris models were used in this study.

## RESULTS AND DISCUSSION

Figure 1 shows adsorption kinetics of the 4-MBC on selected types of MPs during different contact time. The adsorption of 4-MBC on PEg, PP and PLA increased rapidly in first 6 h, after which the adsorption rate slowed down and equilibrium was reached. On the other hand, during the adsorption of

4-MBC on PET, adsorption kinetic occurred slower. During the adsorption of 4-MBC on PET equilibrium was established after 24 h.

The obtained results showed that the 4-MBC has different adsorption affinities depending on type of MPs following this order: PET>PEg≈PP>PLA. The attained results indicated that the highest adsorption affinity of 4-MBC occurred on PET ( $q_i=11.5 \mu\text{g/g}$ ). Based on the obtained results, similar adsorption capacity were achieved for adsorption of 4-MBC on PEg and PP which was around  $q_i=8.5 \mu\text{g/g}$ . Additionally, it can be assumed that presence of voluminous functional terephthalate group in the structure of PET is responsible for slightly higher adsorption affinity of 4-MBC, in comparison to PEg, PP and PLA [1,8,24].

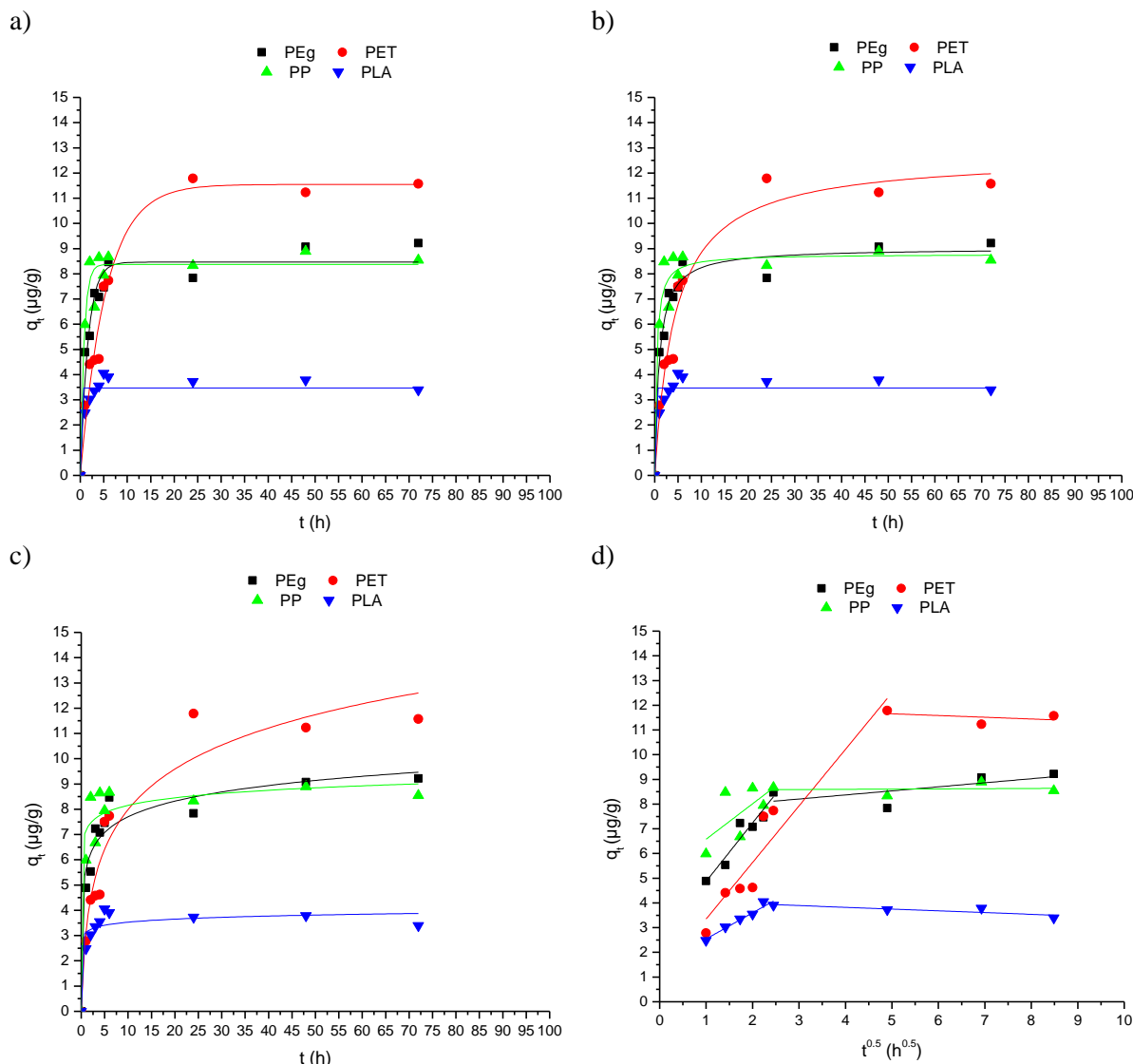


**Figure 1.** Experimental data ( $n = 2$ , mean value  $\pm$ SD) for adsorption kinetics of 4-MBC on PEg, PET, PP and PLA

The lowest adsorption affinity,  $q_i=3.52 \mu\text{g/g}$ , 4-MBC had toward selected type of biodegradable microplastic, PLA. It can be considered as an advantage of this type of BP. The oxygen-containing functional groups such as carbonyl group in PLA can act as H-bond acceptors which can interact with water molecules creating hydrogen bond donors that can form water clusters on the surface of PLA [25,26]. In addition, the formation of 3D water clusters can reduce the accessibility of 3-MBC and cause its lower adsorption rate on PLA. The results are in line with results by Wang and Wang (2018) who pointed out that adsorption rate of organic pollutants is impacted by MPs type [27].

In order to better understand adsorption kinetics of 4-MBC on selected MPs, four widely accepted kinetic models – the pseudo-first-order (PFO) and pseudo-second-order (PSO) models, Elovich (E) and Weber-Morris (W-M) model – were applied to fit the experimental data (Figure 2, table 2).

The correlation coefficients ( $R^2$ ) attained by applying all selected kinetic models (Figure 2a-c, table 2) for adsorption of 4-MBC on PEg, PET, PP and PLA are very high ( $R^2 = 0.831-0.968$ ). However, slightly higher  $R^2$  values were obtained with PSO model for adsorption of 4-MBC on PEg, PET and PP implying that chemisorption is possible adsorption mechanism. On the other hand, Elovich model fitted data better for adsorption of 4-MBC. These results implied that multilayer adsorption occurs between selected UV filter and surface of PLA [28].



**Figure 2.** Plots for the adsorption kinetics, based on the (a) pseudo-first-order model, (b) pseudo-second order model, (c) Elovich and (d) Weber-Morris model, of 4-MBC on PEG, PET, PP and PLA particles in the synthetic water matrix

**Table 2.** Values calculated by kinetic models for adsorption of 4-MBC on MPs

Sorbent	Pseudo-first order			Pseudo-second order					Elovich		
	$k_1$ ( $\text{h}^{-1}$ )	$q_e$ ( $\mu\text{g/g}$ )	$R^2$	$k_2$ ( $\text{g}/\mu\text{g h}$ )	$h$ ( $\mu\text{g/g h}$ )	$q_e$ (theoretical) ( $\mu\text{g/g}$ )	$q_e$ (experimental) ( $\mu\text{g/g}$ )	$R^2$	$\alpha$ $\mu\text{g/g h}$	$\beta$ $\mu\text{g/g}$	$R^2$
PEg	0.61	8.46	0.943	0.12	9.76	9.02	9.08	0.968	492.0	1.12	0.939
PET	0.18	11.5	0.960	0.02	3.20	12.7	11.7	0.962	6.602	0.42	0.932
PP	1.29	8.37	0.940	0.31	23.9	8.78	8.47	0.943	7.11E6	2.32	0.916
PLA	99.8	3.47	0.833	8.52E4	10.6E <sup>5</sup>	3.52	3.85	0.831	9.33E6	5.69	0.879

<sup>a</sup> $k_1$  - rate constant of first-order sorption; <sup>b</sup> $q_e$  - adsorption capacity; <sup>c</sup> $R^2$  - correlation coefficient; <sup>d</sup> $k_2$  - rate constant of second-order sorption; <sup>e</sup> $q_e$  - equilibrium adsorption capacity

In order to investigate the contribution of intraparticle diffusion to the overall adsorption process of 4-MBC on PEG, PET, PP and PLA, the W-M model was applied (Figure 2d). The plots of the W-M model show if intraparticle diffusion may be the rate limiting factor which controls the adsorption process. The obtained results indicated that first and fastest adsorption step occurred in the first few hours, after which the second, slower step occurs during the equilibrium stage [29].

## CONCLUSION

The preliminary study were based on the adsorption kinetics of 4-MBC on different types of granulated MPs. The adsorption kinetic of selected UV filter onto commercially available MPs mainly followed the PSO model indicating that monolayer adsorption which is controlled by chemical process. On the other hand, when it comes to adsorption of 4-MBC on PLA, multilayer adsorption occurs on the surface of selected biodegradable MPs. Furthermore, Weber-Morris model pointed out to multi-stage adsorption process, revealing that intraparticle diffusion is a limiting factor for the adsorption process. Based on the obtained preliminary results, we confirmed adsorption of 4-MBC on MPs and that MPs can act as a carrier of 4-MBC if it get released into the environment. Further investigations regarding 4-MBC and MPs are going to be focused on investigating adsorption mechanism, as well as the influence of different environmental conditions.

## ACKNOWLEDGEMENT

The authors acknowledge financial support of the Ministry of Education, Science and Technological Development of the Republic of Serbia (Grant No. 451-03-9/2021-14/200125).

## REFERENCES

- [1] F.G. Torres, D.C. Dioses-Salinas, C.I. Pizarro-Ortega, G.E. De-la-Torre, Sorption of chemical contaminants on degradable and non-degradable microplastics: Recent progress and research trends, *Sci. Total Environ.* 757 (2021) 143875.
- [2] G.E. De-la-Torre, D.C. Dioses-Salinas, C.I. Pizarro-Ortega, L. Santillán, New plastic formations in the Anthropocene, *Sci. Total Environ.* 754 (2021) 142216.
- [3] R.C. Thompson, Y. Olson, R.P. Mitchell, A. Davis, S.J. Rowland, A.W.G. John, D. McGonigle, A.E. Russell, Lost at Sea: Where Is All the Plastic?, *Science* (80-. ). 304 (2004) 838.
- [4] G.E. De-la-Torre, D.C. Dioses-Salinas, J.M. Castro, R. Antay, N.Y. Fernández, D. Espinoza-Morriberón, M. Saldaña-Serrano, Abundance and distribution of microplastics on sandy beaches of Lima, Peru, *Mar. Pollut. Bull.* 151 (2020) 110877.
- [5] D.C. Dioses-Salinas, C.I. Pizarro-Ortega, G.E. De-la-Torre, A methodological approach of the current literature on microplastic contamination in terrestrial environments: Current knowledge and baseline considerations, *Sci. Total Environ.* 730 (2020) 139164.
- [6] R. Mao, Y. Hu, S. Zhang, R. Wu, X. Guo, Microplastics in the surface water of Wuliangshuai Lake, northern China, *Sci. Total Environ.* 723 (2020) 137820.
- [7] D. Brennecke, B. Duarte, F. Paiva, I. Caçador, J. Canning-Clode, J.~ Ao Canning-Clode, Microplastics as vector for heavy metal contamination from the marine environment, *Estuar. Coast. Shelf Sci.* 178 (2016) 189–195.
- [8] J. Li, K. Zhang, H. Zhang, Adsorption of antibiotics on microplastics, *Environ. Pollut.* 237 (2018) 460–467.
- [9] W. Wang, J. Wang, Comparative evaluation of sorption kinetics and isotherms of pyrene onto microplastics, *Chemosphere.* 193 (2018) 567–573.
- [10] F. fei Liu, G. zhou Liu, Z. lin Zhu, S. chun Wang, F. fei Zhao, Interactions between microplastics and phthalate esters as affected by microplastics characteristics and solution chemistry, *Chemosphere.* 214 (2019) 688–694.
- [11] W. Mei, G. Chen, J. Bao, M. Song, Y. Li, C. Luo, Interactions between microplastics and organic compounds in aquatic environments: A mini review, *Sci. Total Environ.* 736 (2020) 139472.
- [12] A. Tubić, M. Lončarski, T. Apostolović, M. Kragulj Isakovski, J. Tričković, J. Molnar Jazić, J. Agbaba, Adsorption mechanisms of chlorobenzenes and trifluralin on primary polyethylene microplastics in the aquatic environment, *Environ. Sci. Pollut. Res.* (2021).
- [13] M. Lončarski, V. Gvoić, M. Prica, L. Cveticanin, J. Agbaba, A. Tubić, Sorption behavior of polycyclic aromatic hydrocarbons on biodegradable polylactic acid and various nondegradable microplastics: Model fitting and mechanism analysis, *Sci. Total Environ.* 785 (2021).

- [14] A.L. Andrady, Microplastics in the marine environment, *Mar. Pollut. Bull.* 62 (2011) 1596–1605.
- [15] A.J.M. Santos, M.S. Miranda, J.C.G. Esteves da Silva, The degradation products of UV filters in aqueous and chlorinated aqueous solutions, *Water Res.* 46 (2012) 3167–3176.
- [16] W.W.P. Lai, K.L. Chen, A.Y.C. Lin, Solar photodegradation of the UV filter 4-methylbenzylidene camphor in the presence of free chlorine, *Sci. Total Environ.* 722 (2020) 137860.
- [17] M.I. Cadena-Aizaga, S. Montesdeoca-Esponda, M.E. Torres-Padrón, Z. Sosa-Ferrera, J.J. Santana-Rodríguez, Organic UV filters in marine environments: An update of analytical methodologies, occurrence and distribution, *Trends Environ. Anal. Chem.* 25 (2020).
- [18] Michael Daugherty, Adsorption of organic pollutants to microplastics: The effects of dissolved organic matter, Master Thesis. (2016).
- [19] L. Sørensen, E. Rogers, D. Altin, I. Salaberria, A.M. Booth, Sorption of PAHs to microplastic and their bioavailability and toxicity to marine copepods under co-exposure conditions, *Environ. Pollut.* 258 (2020) 113844.
- [20] E.L. Teuten, S.J. Rowland, T.S. Galloway, R.C. Thompson, Potential for plastics to transport hydrophobic contaminants, *Environ. Sci. Technol.* 41 (2007) 7759–7764.
- [21] L. Zhao, L. Rong, J. Xu, J. Lian, L. Wang, H. Sun, Sorption of five organic compounds by polar and nonpolar microplastics, *Chemosphere.* 257 (2020) 127206.
- [22] M. Lončarski, A. Tubić, M.K. Isakovski, B. Jovic, T. Apostolovic, J. Nikic, J. Agbaba, Modelling of the adsorption of chlorinated phenols on polyethylene and polyethylene terephthalate microplastic, *J. Serbian Chem. Soc.* 85 (2020) 697–709.
- [23] A. Tubić, M. Lončarski, S. Maletić, J.M. Jazić, M. Watson, J. Tričković, J. Agbaba, J. Molnar Jazić, M. Watson, J. Tričković, J. Agbaba, J.M. Jazić, M. Watson, J. Tričković, J. Agbaba, Significance of Chlorinated Phenols Adsorption on Plastics and Bioplastics during Water Treatment, *Water (Switzerland)*. 11 (2019) 2358.
- [24] K.N. Fotopoulou, H.K. Karapanagioti, Surface properties of beached plastic pellets, *Mar. Environ. Res.* 81 (2012) 70–77.
- [25] S. Endo, S.T.J. Droge, K.-U. Goss, Polyparameter Linear Free Energy Models for Polyacrylate, *Anal. Chem.* 83 (2011) 1394–1400.
- [26] F. Wang, M. Zhang, W. Sha, Y. Wang, H. Hao, Y. Dou, Y. Li, Sorption behavior and mechanisms of organic contaminants to nano and microplastics, *Molecules.* 25 (2020).
- [27] W. Wang, J. Wang, Different partition of polycyclic aromatic hydrocarbon on environmental particulates in freshwater: Microplastics in comparison to natural sediment, *Ecotoxicol. Environ. Saf.* 147 (2018) 648–655.
- [28] M.L. Soto, A. Moure, H. Domínguez, J.C. Parajó, Recovery, concentration and purification of phenolic compounds by adsorption: A review, *J. Food Eng.* 105 (2011) 1–27.
- [29] W.H. Cheung, Y.S. Szeto, G. McKay, Intraparticle diffusion processes during acid dye adsorption onto chitosan, (2006).

## COMPARISON OF SURFACE WATER QUALITY BETWEEN CROSS-BORDER PROTECTED AREAS IN SERBIA AND CROATIA

Boris Obrovski<sup>1</sup>, Mirjana Vojinović Miloradov<sup>1</sup>, Maja Sremački<sup>1</sup>, Mladenka Novaković<sup>1</sup>, Nevena Živančev<sup>1</sup>, Maja Petrović<sup>1</sup>, Ivana Mihajlović<sup>1</sup>

<sup>1</sup> University of Novi Sad, Faculty of Technical Sciences, Novi Sad, Serbia

e-mail: [mladenkanovakovic@uns.ac.rs](mailto:mladenkanovakovic@uns.ac.rs)

**Abstract:** The paper provides comprehensive overview of the surface water quality data collected for cross-border protected areas of the Lake Zobnatica, Serbia and the Tompojevci wetlands, Croatia. The surface water pollution from agricultural activities requires a comprehensive and continuous long-term monitoring program. The presence of ten key physico-chemical parameters in two cross-border protected areas over a two-year period was investigated. Furthermore, the total pollution of observed areas was compared as the result of similarities identified throughout the research. Based on the collected data, it was possible to determine that the surface water of selected sites belongs to the same water class according to the national legislation of both countries. Individual sample *t-tests* were used to define differences in contamination of protected areas. The results obtained by statistical data evaluation show that despite the observed similarities of the locations, there are significant differences in obtained values for the pH, electrical conductivity (EC), dissolved oxygen, nitrates, sulphates, chloride, and total chlorine.

**Key words:** surface water, environment, monitoring, statistical analyses

### INTRODUCTION

The purpose of the long-term monitoring study and programme is to provide detailed and comprehensive database on the current state of surface water quality in protected areas. An insight into the current state of the water body enables identification of potential pollution sources and implementation of necessary prevention and minimization measures. Monitoring of surface water quality is of immense importance, particularly for sensitive water bodies (lakes and wetlands), considering the scope of the anthropogenic activities (predominantly agricultural) and expanding urbanization of the coastal terrain [1, 2]. The key pathways of surface water contamination are groundwater pollution, run-off water from agricultural areas, wind-borne pollution, and the direct discharge of urban effluent and waste.

Intense agricultural activity and use of fertilizers has a severe impact on the quality of environment, particularly on soil, ground and surface water [3]. Diffuse source pollution is difficult to monitor, therefore, it is imperative to conduct continuous long-term monitoring programme (LTMP) [4, 5, 6]. Temporal and spatial distribution of key physico-chemical parameters is essential for evaluation of surface water quality, especially nitrogen and phosphorus compounds that can cause the eutrophication process [7, 8, 9, 10]. The eutrophication process can be devastating for sensitive water bodies, primarily lakes and wetlands, as the quantity of dissolved oxygen decreases, threatening the survival of aquatic organisms. Elevated chloride concentrations in surface water do not harm the environment, but they are implemented as pollution indicators, where high levels correspond with the presence of hazardous or toxic contamination [11].

In the research, the key physico-chemical parameters of water in two cross-border protected areas, Lake Zobnatica in Serbia and Wetlands of Tompojevci in Croatia, were seasonally monitored over the period of two years. Monitored locations have significant environmental and geo-topographical similarities - both sites are intended to be protected areas, water bodies are surrounded by agricultural land with same crops (wheat, corn and sunflower) as well as urban areas, and protective vegetation belt is scarce and underdeveloped.

The main objective of this research paper is to investigate the quality of surface water in two cross-border protected areas by comparing concentrations of ten key physico-chemical parameters. The comprehensive database and the results of evaluated data set will be used to develop protective measures with the objective to reduce anthropogenic impact on the environment.

## MATERIAL AND METHODS

Lake Zobnatica is located in the North Bačka District near the town of Bačka Topola, and Wetlands of Tompojevci are located in the eastern part of Vukovar-Srijem District, Tompojevci municipality. Surface water samples were collected from three locations in Lake Zobnatica and two locations in Wetlands of Tompojevci (Table 1). Samples are collected in 1 L bottles, stored in hand refrigerator at 4 °C, and transported to the Laboratory. Analyses were carried out in Accredited Laboratory for environmental and occupational monitoring, Department of Environmental Engineering and Occupational Safety and Health, University of Novi Sad.

Throughout the research period of two years, seasonally ten physico-chemical parameters have been monitored in surface water samples. Measurement of pH, dissolved oxygen and electrical conductivity was performed in the field using a multiparameter device. Standard EPA and HACH methods were used for analyses of orthophosphate (EPA 150.1), nitrate (EPA 360.1), ammonia (EPA 365.3), sulphate (HACH 8507), chloride (HACH 8192), total chlorine (HACH 8051) and chromium(VI) (HACH 8113). The concentrations of all parameters were measured via UV-VIS spectrophotometer (DR 5000, HACH, Germany).

**Table 1.** Coordinates of surface sampling sites

Lake Zobnatica, Serbia	Wetlands of Tompojevci, Croatia
SW1 (45°85'7.11" N, 19°62'23.58" E)	POV1 (45°24'33.95" N, 19°11'19.88" E)
SW2 (45°88'20.36" N, 19°60'92.59" E)	POV2 (45°24'29.82" N, 19°09'67.98" E)
SW3 (45°84'03.13" N, 19°62'60.93" E)	

### Statistical data analysis

The IBM SPSS (Statistical Package of Social Science) software package version 25 was used for statistical data analyses. Descriptive statistic and independent sample *t-test* were performed for the analysis of data collected over a period of two years.

## RESULTS AND DISCUSSION

Descriptive statistics was applied for determining basic statistical aggregated functions (mean, minimum and maximum) of the observed physico-chemical parameters (Table 2 and 3). By comparing the mean, minimum and maximum values for each parameter in relation to the law and bylaw regulations (Official Gazette of the RS no. 50/2012 for Serbia and Official Gazette no. 77/98 and no. 137/08 for Croatia) the class of surface water was determined (Table 2 and 3). Zobnatica lake and Wetlands Tompojevci belong to the III class of surface water with moderate ecological status.

**Table 2.** Descriptive statistic for analyzed physico-chemical parameters in Lake Zobnatica

Parameters	Unit	Lake Zobnatica			
		Mean	Min.	Max.	Class
pH	-	8.37 ± 0.58	7.48	9.66	I
Electrical conductivity (EC)	µS/cm	1013.8 ± 70.84	920	1165	II
Dissolved oxygen	mg/L	8.37 ± 5.74	2.87	15.2	I
Orthophosphate	mg/L	0.282 ± 0.401	0.00	1.26	III
			5	3	



Nitrate	mg/L	0.019 ± 0.012	0.01	0.06	I
Ammonia	mg/L	0.045 ± 0.053	0.00 5	0.22 0	I
Sulphate	mg/L	73.73 ± 29.96	1	98	II
Chloride	mg/L	59.50 ± 31.73	3.40	117. 1	II
Total chlorine	mg/L	0.027 ± 0.029	0.01	0.14	II
Chromium (VI)	mg/L	0.011 ± 0.023	0.00 5	0.11 8	I

**Table 3.** Descriptive statistics for analyzed physico-chemical parameters in Wetlands of Tompojevci

Parameters	Unit	Wetlands of Tompojevci			
		Mean	Min.	Max.	Class
pH	-	7.71 ± 0.46	7.19	8.81	I
Electrical conductivity (EC)	µS/cm	513.75 ± 144.06	308	948	I
Dissolved oxygen	mg/L	4.64 ± 0.56	3.73	5.62	III
Orthophosphate	mg/L	0.479 ± 0.57	0.00 5	1.88 7	III
Nitrate	mg/L	0.01 ± 0.008	0.01	0.03	I
Ammonia	mg/L	0.183 ± 0.33	0.01	1.29	I
Sulphate	mg/L	10.14 ± 18.05	1	63	I
Chloride	mg/L	16.31 ± 10.47	3.80	37.2	I
Total chlorine	mg/L	0.058 ± 0.048	0.01	0.14	II
Chromium (VI)	mg/L	0.010 ± 0.009	0.00 5	0.03 7	I

Results of the research demonstrate whether there is a significant difference in cumulative surface water pollution between the two observed cross-border protected areas. An independent sample *t-test* was used to examine distinctions between two sites. Based on the results shown in Table 4, it is concluded that there is a statistically significant difference for pH, EC, dissolved oxygen, nitrates, sulphates, chloride and total chlorine in relation to the observed cross-border areas.

**Table 4.** Comparison of key physico-chemical parameters in surface water by locations

Parameters	Zobnatica lake	Wetlands of Tompojevci	t value	Significance (p value)
	Mean			
pH	8.37 ± 0.58	7.71 ± 0.46	3.796	0.001*
Electrical conductivity (EC)	1013.8 ± 70.84	513.75 ± 144.06	14.844	<0.0005*
Dissolved oxygen	8.37 ± 5.74	4.64 ± 0.56	2.128	0.044*
Orthophosphate	0.282 ± 0.401	0.479 ± 0.57	1.234	0.225
Nitrate	0.019 ± 0.012	0.01 ± 0.008	2.384	0.023*
Ammonia	0.045 ± 0.053	0.183 ± 0.33	1.549	0.145
Sulphate	73.73 ± 29.96	10.14 ± 18.05	7.166	<0.0005*
Chloride	59.50 ± 31.73	16.31 ± 10.47	6.010	<0.0005*
Total chlorine	0.027 ± 0.029	0.058 ± 0.048	2.178	0.020*
Chromium (VI)	0.011 ± 0.023	0.010 ± 0.009	0.118	0.907

\*Statistical significance at the level of 0.05

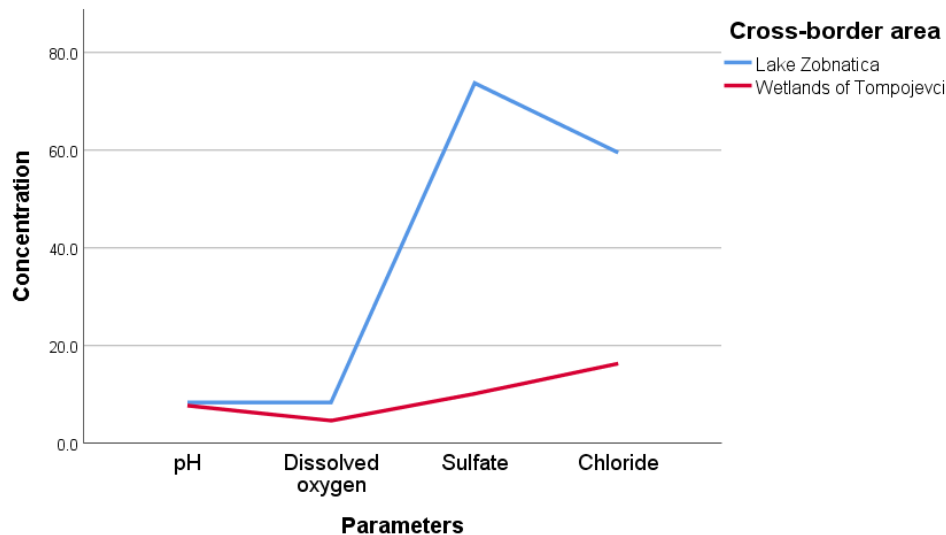


Fig. 1. Comparison of pH, dissolved oxygen, sulphate and chloride by location

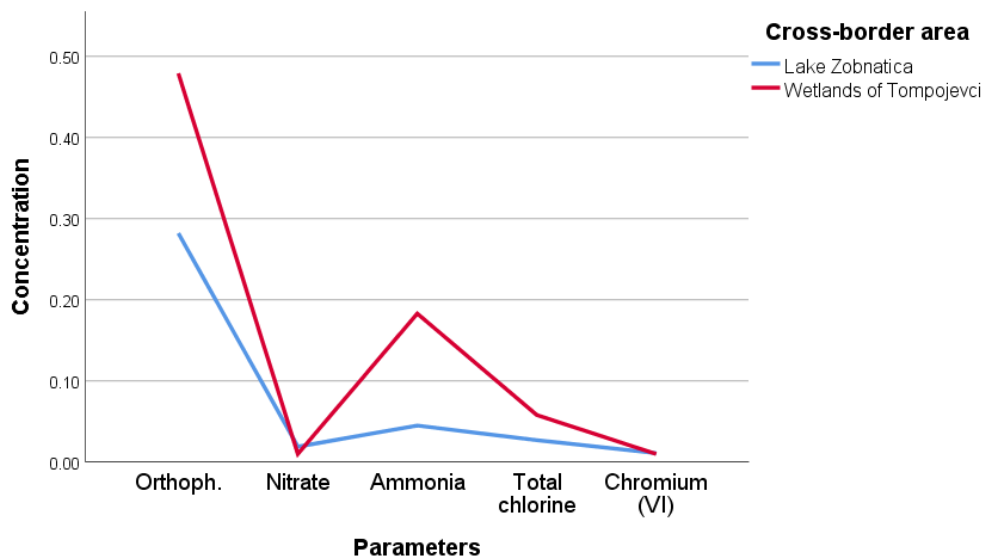


Fig. 2. Comparison of orthophosphate, nitrate, ammonia, total chlorine and chromium(VI) by location

Concentrations of dissolved oxygen, sulphate, chloride and pH value are elevated in Lake Zobnatica, but not in Wetlands of Tompojevci (Figure 1). Figure 2 reveals that the concentrations of orthophosphate, ammonia and total chlorine are elevated in Wetlands of Tompojevci compared to Lake Zobnatica, while the concentrations of nitrate and chromium(VI) are relatively close.

Excess orthophosphates present the highest risk for the observed water bodies. Elevated orthophosphate concentrations are in close relation with the lower values of dissolved oxygen, indicating the preliminary phase of eutrophication. The sources of elevated orthophosphate concentrations are anthropogenic activities, mainly agricultural activities utilizing phosphorus-based fertilizers (PBF). The obtained results for nitrate compounds (nitrates and ammonia) indicate that the use of nitrogen-based fertilizers (NBF) is either not as wide-spread as PBF or they are used optimally, so there is no indication of water pollution. Chlorides are used as ecological indicators of groundwater contamination, with elevated concentrations indicating the existence of other toxic pollutants.

## CONCLUSION

Long-term monitoring programme of surface waters is necessary, particularly for protected water bodies where there is significant anthropogenic impact, mainly from agriculture and urban effluents

and wastes. Agricultural land in vicinity of protected and sensitive water body could cause high risk situation, since the significant number of bio-chemical agents used for the purpose of crop protection indicate the contamination of water and soil. For the first time, a study of comparative monitoring of surface water quality of two cross-border protected areas with relatively similar characteristics in Serbia and Croatia was conducted. The results obtained through two-year monitoring can be used to enable decision-making process in the field of surface water management, which is extremely important for areas where there is a persistent anthropogenic impact on the aquatic systems. Currently, the observed water bodies, Lake Zobnatica and Wetlands of Tompojevci, have relatively good quality, but it is necessary to take preventive measures related to the expansion of protective vegetation belt. In these research areas, the protective vegetation belt can reduce run-off pollution from agricultural areas, and fundamentally impact the concentration levels of nitrogen and phosphorus based contaminants. A well designed vegetation belt on observed locations will effectively protect the aquatic system from contamination and reduce the risk of eutrophication, which highly impacts still water bodies, such as lakes and wetlands.

## **ACKNOWLEDGMENT**

This work was supported in part by Active Sensor Monitoring Network and Environmental Evaluation for Protection and Wise use of Wetlands and Other Surface Waters project (acronym SeNs Wetlands, grant agreement no 2017HR-RS135) within Interreg IPA CBC Croatia-Serbia Programme, the Ministry of Education, Science and Technological Development through the project no. 451-03-68/2020-14/200156: “Innovative scientific and artistic research from the FTS domain”, the Bilateral project funded by the Ministry of Education, Science and Technological Development (contract no. 337-00-107/2019-09/16) and Slovak Research and Development Agency under contract SK-SRB-18-0020.

## **REFERENCES**

- [1] McLaughlin, D.L., Cohen, M.J., Realizing ecosystem services: wetland hydrologic function along a gradient of ecosystem condition, *Ecological Applications*, Vol. 23, pp. 1619–1631, 2013.
- [2] Chen, W.; Cao, C.; Liu, D.; Tian, R.; Wu, C.; Wang, Y.; Qian, Y.; Ma, G.; Bao, D. An evaluating system for wetland ecological health: Case study on nineteen major wetlands in Beijing-Tianjin-Hebei region, China, *Science of Total Environment*, Vol. 666, pp.1080–1088, 2019.
- [3] Tilman, D., Cassman, K.G., Matson, P.A., Naylor, R., Polasky, S., Agricultural sustainability and intensive production practices, *Nature*, Vol. 418, pp. 671-677, 2002.
- [4] Balestrini, R., Sacchi, E., Tidili, D., Delconte, C.A., Buffagni, A., Factors affecting agricultural nitrogen removal in riparian strips: examples from groundwater dependent ecosystems of the Po Valley (northern Italy), *Agriculture, Ecosystems & Environment*, Vol. 221, pp.132–144, 2016.
- [5] Sebilio, M., Mayer, B., Nicolardot, B., Pinay, G., Mariotti, A., Long-term fate of nitrate fertilizer in agricultural soils, *Proceedings of the National Academy of Sciences*, Vol.110, pp. 18185–18189, 2013.
- [6] Dalgaard, T., Hutchings, N., Dragosits, U., Olesen, J.E., Kjeldsen, C., Drouet, J.L., Cellier, P., Effects of farm heterogeneity and methods for upscaling on modelled nitrogen losses in agricultural landscapes, *Environmental Pollution*, Vol.159, pp. 3183–3192, 2011.
- [7] Dwivedi, D., Arora, B., Steefel, C.I., Dafflon, B., Versteeg, R., Hot spots and hot moments of nitrogen in a Riparian Corridor, *Water Resources Research*, Vol. 54, pp. 205–222, 2018.
- [8] Gutierrez, M., Biagioni, R.N., Alarcon-Herrera, M.T., Rivas-Lucero, B.A., An overview of nitrate sources and operating processes in arid and semiarid aquifer systems, *Science of Total Environment*, Vol. 624, pp. 1513-1522, 2018.
- [9] Mekonnen, M.M., Hoekstra, A.Y., Global gray water footprint and water pollution levels related to anthropogenic nitrogen loads to fresh water, *Environmental Science and Technology*, Vol. 49, pp. 12860-12868, 2015.

- [10] Nikolenko, O., Jurado, A., Borges, A.V., Knöller, K., Brouyere, S., Isotopic composition of nitrogen species in groundwater under agricultural areas: a review, *Science of Total Environment*, Vol. 621, pp. 1415-1432, 2018.
- [11] Patel, M., Gami, B., Patel, A., Patel, P., Patel, B., Climatic and anthropogenic impact on groundwater quality of agriculture dominated areas of southern and central Gujarat, India, *Groundwater for Sustainable Development*, Vol.10, pp.100306, 2020.

## EFFECTS OF ENVIRONMENTAL POLLUTION DUE TO LAND TRANSPORT ACTIVITY

Luisa Izabel Dungan<sup>1</sup>, Adrian Eugen Cioabla<sup>1</sup>, Mircea Adrian Dungan<sup>2</sup>,  
Mariana Nela Stefanut<sup>3</sup>, Francisc Popescu<sup>1</sup>,

<sup>1</sup>University Politehnica Timisoara, Faculty of Mechanical Engineering, Timisoara, Romania

<sup>2</sup>SNTFC CFR CALATORI SA, Timisoara, Romania

<sup>3</sup>National Institute of Research and Development for Electrochemistry and Condensed Matter,  
Timisoara, Romania

e-mail: [adrian.cioabla@upt.ro](mailto:adrian.cioabla@upt.ro)

**Abstract:** In the literature it is specified that any transport activity has a major impact on the environment, and in accordance with the Environmental Protection Law 137/1995 this impact must be assessed in terms of its negative influence. Studies conducted near the transport infrastructure have shown that approximately 65% of the pollutants emitted by vehicles and over 50% of the pollutants emitted by the rolling stock are dispersed in the vicinity of the transport infrastructure contaminating the environment. The paper presents the heavy metals pollution, their effect on the environment as well as the results of research conducted in the junction area of those two transport systems (road and rail) in the southern part of Timisoara city.

**Key words:** transport infrastructure, environmental law, polluting factors, pollutants.

### INTRODUCTION

Transport presents real challenges as society tries to ensure the increasing of people standard life level and more environmentally safely future.

The transport networks are one of the keys of progress. The impact of transportation on environment consists in soil erosion, soil contamination and frequently in contamination both of air and water and soil. The using of toxic materials in transport industry can determine contamination of soil and some variations of natural vegetation. Unintentionally leaks of fuel and oil from motor vehicles are often washed on roadsides and penetrate into the soil. There are many chemicals used for maintained of railroad which represented a certified way to soil contamination. Usually, near railroads, ports and airports, large concentrations of hazardous materials and heavy metals can be found [1].

The industrial development has produced an increasing of environmental issue relative to contamination with heavy metals. This problem is enhanced by industrialization, urbanization, agricultural use of large quantities of fertilizers and pesticides and also by human impact. Zwolak et al. [2] sustained the fact that, the general categories of emissions involved by human activities are:

- a. Emissions from sources connected vehicle transport and fuels, described as linear emissions;
- b. Processes like energy combustion using energy carriers, and industrial processes, like discharging substances into the air through different emitters, considered as point emission sources;
- c. Emissions connected with house heating in the municipal and household sector, presented as surface emissions.

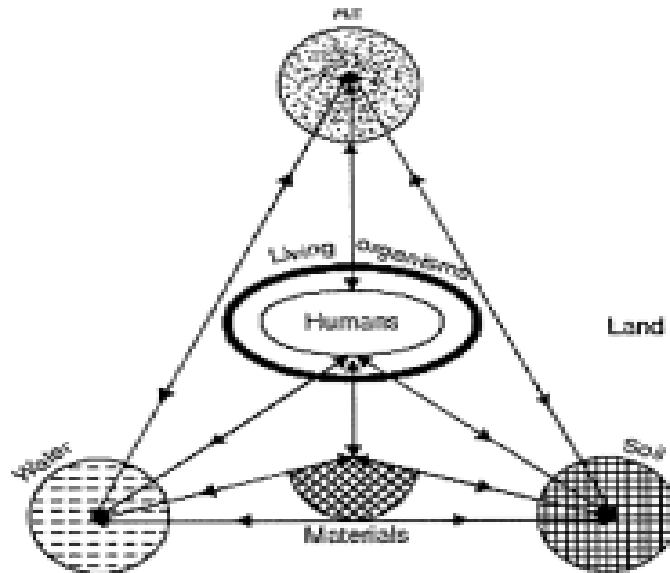
Overall accumulation of metals in soil and vegetables is an important source of interference with the food chain. In this regard, heavy metals fluctuation in the soil, their uptake by plants, human expo-sure to heavy metals by means of consumption different food components which are considered to be contaminated and their possible toxicity, creates problems nowadays.

The grown of vegetable crops near industrial plants and busy roads, together with overall exposure of different types of crops to municipal sources of pollution and agricultural wastewaters can determine the increasing of containing of certain elements.

This can lead to a non-equilibrated balance of overall elements, and can affect their general interaction with other food ingredients [3, 4]. There are many methods for metals extraction from soil: sequential extraction, aqua regia digestion [5], ultrasonically and microwave digestion, dry ashing and there are many methods for analyses that is inductively plasma coupled (ICP-OES), atomic absorption spectrometry (AAS) [6], etc.

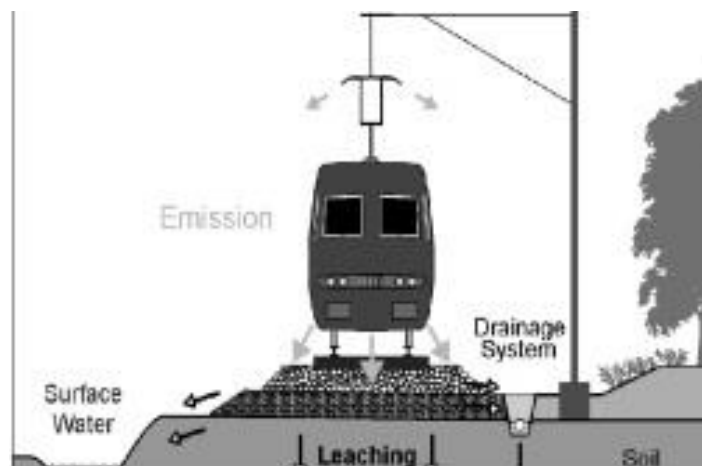
Environment is derived from the French word “Environner”, which means to encircle or surround. All the biological and non-biological entities surrounding us are included in environment. As per Environment (Protection) Act, 1986, environment includes in general, all physical and biological surroundings of an organism along with their interactions.

According to [7], environment is thus defined as “the total sum of water, air and land and the interrelationships that exist among them and with the human beings, other living organisms and materials”. This is schematically presented in Fig. 1 [7].



**Fig. 1.** Concept of Environment: air, water, land, living organisms and materials surrounding us and their interactions together constitute environment [7]

In fact, transport sector can be considered as an important source of diffuse pollution to the environment. Until now, different studies had as a general focus the road traffic pollution, but there is little information in regards to railways. However, railway operation is presently associated with the influence of different inorganic and organic substances with a high level of impact on the environment (Fig. 2) [8].



**Fig. 2.** Spatial distribution of substances emitted by regular railway operation and their influence on environment [8]

Particularly, this paper presents a summary of field test results and the comprehensive results from laboratory studies on the concentration of heavy metals generated by the railway rolling stock and autos in southern part of Timisoara using a non-conventional method [9] for evaluation of the state of pollution through statistical analysis of field test results based on experimental optimization methods.

## MATERIALS AND METHODS

Nitric acid 67% ( $\text{HNO}_3$ , free of heavy metals), hydrochloric acid 37% ( $\text{HCl}$ , free of heavy metals), hydrofluoric acid ( $\text{HF}$ ) and boric acid ( $\text{H}_3\text{BO}_3$ ) and all standards for metals were purchased from Merck (Germany). Samples of soils were picked up from railway station Timisoara Sud (Fig.3), Commercial stop Semenik (Fig.4), along Primaverii Street in Chişoda and 3 junction sections in Chisoda and Giroc (Fig.5). These samples were collected between 09-12 October 2017.



**Fig. 3.** Railway station Timisoara Sud.



**Fig. 4.** Commercial stop Semenik.



**Fig. 5.** Primaverii str. and junction sections: Chisoda (Chisodei Path), Chisoda (Nicolae Firu str.), Giroc (Timisoarei Path).

Samples were taken out from the surface of places. Soils were milled, dried and weighted. Then, acidic total digestion of the samples, in closed vessel devices using temperature control microwave heating for metal AAS determination was used. Total digestion of 0.5 g of soils (weighted  $\pm 0.0002$  g precision) with 8 mL nitric acid 67%, 5 mL hydrochloric acid 37%, 1 mL hydrofluoric acid and 5 mL boric acid  $\text{H}_3\text{BO}_3$  5% was prepared. The process was realized in Milestone Ethos apparatus equipped with easyCONTROL software and HPR1000/10S high pressure segmented rotor and with an internal temperature sensor. The microwave program was performed in two steps (Table 2).

**Table 1.** Samples presentation

Sample	Parameter			
	Humidity (%)	Weight (g)	Volume (mL)	Dilution grade
Soil 1	0.80	0.5210	25	1:20
Soil 2	1.30	0.5243	25	1:20
Soil 3	4.56	0.5207	25	1:20
Soil 4	8.15	0.5179	25	1:20
Soil 5	2.00	0.5198	25	1:20
Soil 6	2.93	0.5154	25	1:20

**Table 2.** Microwave program

Step	Parameter		
	Time (min)	T1 sensor (°C)	Power (W)
1	15	200	1200
2	15	200	1200

Soil samples were taken as follows:

- Soil 1 from Calea Timisoarei
- Soil 2 from Primaverii Str.
- Soil 3 from Semenici
- Soil 4 from Calea Chisodei
- Soil 5 from Timisoara Sud
- Soil 6 from Nicolae Firu

After digestion, all samples were quantitative brought to 25 ml. In AAS analyses, dilution 1:20 for each sample was made. AAS analyses were performed using novAA 400G apparatus equipped with an Analytik Jena graphite furnace and provided with WinAAS 3.17.0 soft for evaluation, control and results display and Cookbook for all elements. Calibration curves have been plotted using standard solutions of metals in search (Table 3). Heavy metals such as Cr, Fe, Pb, Mn, Ni, Co, Hg, Cd, Zn were followed.

**Table 3.** Calibration curve for heavy metals

Sample	Parameter			
	Calibration curve	Relative Coeff. R	Linear Range (µg/L)	λ (nm)
Cr	$y = 0.011925 + 0.01439 x$	0.9912	0-22	357.9
Fe	$y = 0.142372 + 1.547592 x$	0.9842	0-1100	302.1
Pb	$y = 0.003424 + 0.002982 x$	0.9974	0-32.6	283.3
Mn	$y = 0.007635 + 0.050342 x$	0.9962	0-4.62	279.5
Ni	$y = 0.008684 + 0.004832 x$	0.9974	0-34.6	232.0
Co	$y = 0.007448 + 0.008841 x$	0.9974	0-23.8	240.7
Hg	$y = 0.000384 + 0.000095 x$	0.9123	0-26.4	253.7
Cd	$y = 0.01477 + 0.095479 x$	0.9989	0-2	228.8
Zn	$y = 0.042549 + 0.045728 x$	0.9912	0-8.8	213.9

## RESULTS AND DISCUSSION

The concentration of heavy metals in soils was expressed as µg/g dry weight soil (ppm), so the drying process is very important. Soils were dried and the humidity was determined using gravimetric method (105°C). In order to uniform and to compare the results, after chemical digestion, the samples were transferred into 25 mL marked bottles and completed with ultrapure water (laboratory Barnstead



EASYPureRoDi apparatus) to 25 mL. For AAS analyses, 1 mL of analyte (each solution) was diluted for 20 times with 05% HNO<sub>3</sub> (ISO 15586 2003(E)).

All samples were injected in triplicate. The values indicated by the apparatus were multiplied by dilution grade (20) and were reported at 1 g dried material. The results were presented in Tables 4 and 5 (where SD was standard deviation). The soil was sampled from the superficial layer in all mentioned points (depth between 0 – 10 cm).

**Table 4.** Concentration of heavy metals in soils (part 1)

Sample	Parameter			
	Cr±SD (µg/g)	Fe±SD (µg/g)	Pb±SD (µg/g)	Mn±SD (µg/g)
Soil 1	13.1±3.9	7216.9±0.8	14.4±3.3	181.8±1.2
Soil 2	9.4±1.6	9584.2±1.2	20.1±1.6	210.7±1.1
Soil 3	48.6±0.1	16401.0±0.8	27.8±0.6	234.8±1.9
Soil 4	21.7±4.3	11469.4±1.1	12.4±1.2	136.7±1.6
Soil 5	30.2±7.3	15438.6±6.8	40.8±1.2	219.9±1.9
Soil 6	16.7±7.1	12097.4±0.2	19.8±0.3	253.3±5.0

**Table 5.** Concentration of heavy metals in soils (part 1)

Sample	Parameter			
	Ni±SD (µg/g)	Co±SD (µg/g)	Cd±SD (µg/g)	Zn±SD (µg/g)
Soil 1	2.1±0.1	2.04±0.3	abs.	180.81±2.5
Soil 2	9.4±0.2	2.84±0.2	abs.	117.20±5.0
Soil 3	49.1±0.3	4.17±0.0	0.1±0.0	281.64±3.2
Soil 4	28.1±0.3	2.63±0.2	abs.	427.69±7.1
Soil 5	33.3±0.4	3.18±0.2	0.03±0.0	241.05±3.4
Soil 6	1.5±0.0	2.71±0.1	abs.	110.21±1.1

From the samples analysis it can be observed that overall, there are small quantities of heavy metals in the areas taken into consideration, but further investigations must be done, in order to determine the exact sources of contamination in the respective areas and to take good decisions for elimination/diminution of them.

## CONCLUSION

This work presented a rapid microwave acidic method of soil digestion and a very suitable analysis method for metals: atomic absorption spectrometry with graphite furnace (GF-AAS) for heavy metals determination in soils. Registered results showed the presence of Cr, Fe, Pb, Mn, Ni, Co, Cd and Zn in different soils, around Timisoara. Hydrargyrum was not found in the samples. Cadmium was found in soil 3 and soil 5 (0.1; 0.03 µg/g) and total Cr concentration varied between 9-49 µg/g. Large quantities of Zn (110-427µg/g) and Mn (130-250µg/g) were found in all soils. The concentration of Pb varied between 12.4-40.8 µg/g and the concentration of Ni varied between 1.5-49 µg/g. The soil 5 from railway station Timisoara Sud has the higher Pb concentration.

Due to the lack of essential data on emissions of harmful nanoparticles in the atmosphere, it becomes clear that an environmental impact assessment cannot currently be fully established. The evaluation of particulate matter and/or composites pollution in critical areas of railway track is a complex and laborious process, which involves different methods, experiences and expense many resources.

Practical applications determine the use of special methods with the optimization as most important objective. Such modern methods involve, in the same time, both use of nonconventional elements and, also, the use of modern application of statistical methods.

One important part is the application of the collection of samples from critical areas through a statistically optimized distribution so that number of samples to be minimum and relevance to be maximum.

In such situation it is important to use the "Pollution function" as global function, depending on many linked factors. Considering the above we consider that the current research is bringing an added value by further scientific research on the influence of transport on the railway with all its implications on environmental pollution.

## REFERENCES

- [1] Tahzib, B., Zvijakova, L.: Environmental of land transport, Transfer inovaciji, Vol. 24, pp. 70-77, 2012.
- [2] Zvolak, A., Sarzynska, M., Szpyrka, E., Starwarczyk, K.: Sources of Soil Pollution by Heavy Metals and Their Accumulation in Vegetables: A Review, Water Air Soil Pollution, Vol. 230, pp. 164, 2019.
- [3] Wong, C.S.C., Li, X., Thornton, I.: Urban environmental geochemistry of trace metals, Environmental Pollution, Vol. 142(1), pp. 1-16, 2006.
- [4] Smiechowska, M., Florek, A.: Content of heavy metals in selected vegetables from conventional, organic and allotment cultivation, Journal of research and Applications in Agricultural Engineering, Vol. 56, pp. 152-156, 2011.
- [5] Kassalein, M., Yli-Halla, M.: Use of sequential extraction to assess metal partitioning in soils, Environmental Pollution, Vol.126(2), pp.225-233, 2003.
- [6] Bini, C., Sartori, G., Wahsha, M., Fontana, S.: Background levels of trace elements and soil geochemistry at regional level in NE Italy, Journal of Exploration, Vol.109, pp.125-133, 2011.
- [7] Kausnik, C.P, Bhavikatti, S.S., Kausnik, A.: Basic civil and environmental engineering, Daryaganj, Delhi, IND, New Age International, pp. 73, 2010.
- [8] Xun, Z., Xiaozhen, L., Quanmin, L. et al.: Theoretical and experimental investigation on bridge-borne noise under moving high-speed train, Sci. China-Technol. Sci., Vol. 56(4), pp. 917-924, 2013.
- [9] Dungan, M.A., Tucu, D., Jeko, J.: Nonconventional method for evaluating particulate matter and/or composites pollution in critical areas of railway track, Nonconventional Technologies Review, 2013.

## WASTEWATER MANAGEMENT: A STRENGTH OR WEAKNESS OF THE REPUBLIC OF SERBIA ON THE PATH TO THE EU?

Aleksandra Sitarević<sup>1</sup> Aleksandar Sofić<sup>1</sup>

<sup>1</sup>University of Novi Sad, Faculty of Technical Sciences, Novi Sad, Serbia

e-mail: [sicasanjasandra@hotmail.com](mailto:sicasanjasandra@hotmail.com)

**Abstract:** This paper provides an overview of the state of wastewater management in the Republic of Serbia from multiple viewpoints, as well as the position of our country on the path to the EU when it comes to wastewater treatment. More particularly, it provides an overview of the current sewerage network trends and the changes in the percentage of the population that is connected to the municipal wastewater treatment system in the Republic of Serbia. In addition, the amount of discharged wastewater from the territory of the Republic of Serbia is presented, as well as the amount of discharged wastewater in drainage basins in relation to the primary, secondary, and tertiary treatments. The current situation indicates that our country is facing great challenges when it comes to municipal and industrial wastewater management due to the insufficient capacity of local sewage infrastructures, but also in various industries, where there aren't enough developed methods or devices for wastewater treatment. The long-term strategy of the Republic of Serbia in the field of environmental protection implies improving quality of life by providing the desired environmental conditions and preserving nature based on sustainable environmental management, which is also one of the main preconditions for Serbia's accession to the European Union. In the future, it is necessary to integrate environmental policy into other sectors, especially in the fields of economy, agriculture, and energy, as well as more active public participation in decision-making processes.

**Key words:** wastewater, wastewater management, state, perspectives, EU.

### INTRODUCTION

Wastewater is generated after using natural water for a specific purpose, after which it is referred to as "used" or so-called "waste" water. After being used, it becomes contaminated with various impurities – pollutants, after which its physical, chemical, and biological characteristics experience such a change that it becomes unsuitable for its original purpose. Wastewater includes municipal wastewater, industrial wastewater, atmospheric wastewater, infiltration and inflow, agricultural wastewater and landfill wastewater [1].

Large industrial systems mostly contribute to increased atmospheric pollution, which directly affects the environment. Today's industrial sectors are considered the greatest consumers and polluters of water, despite large monetary investments and significant immaterial efforts of the Republic of Serbia for the purification and adequate discharge of water. During the last three decades, physical, chemical, and biological methods for wastewater treatment have become relevant. These include flotation, oxidation, solvent extraction, evaporation, carbon adsorption, ion exchange, membrane filtration, electrochemistry, biodegradation, and phytoremediation [2]. Wastewater treatment mainly goes through three processes – the primary, secondary, and tertiary treatment process, depending on whether the water is treated mechanically, biologically, or chemically [3]. There still isn't an agreed-upon "best" method for water purification because each treatment has its advantages and limitations, not only in terms of costs but also in terms of efficiency, feasibility, and environmental impact. Untreated industrial wastewater is one of the key sources of surface water and groundwater pollution in the Republic of Serbia. Chapter 27 - Environmental Protection, is the most complex in the accession process to the European Union, which implies a long-term adjustment policy of future members that leads to the long-term well-being of all citizens.

At the end, the treatment of municipal wastewater, as well as wastewater from industrial plants connected to municipal sewerage systems, is essential for ensuring public health and improving the quality of the environment [4].

### POLLUTANTS, POLLUTING MATERIAL, AND WATER QUALITY PARAMETERS

Water pollution occurs when water comes in contact with one or more substances that change its chemical compound. These substances can have a negative effect on the health of people, but also animals and their habitats, as well as the environment as a whole [5]. The very fact that water is used for various purposes results in it potentially becoming contaminated during any activity in the household, agriculture, but also in industrial production when it very often contains harmful pollutants. Based on the above, it can be concluded that there are various sources of water pollution, such as industrial waste, mining activities, sewage, pesticides, and chemical fertilizers, energy use, radioactive waste, urban development, etc.

All these sources can be attributed by anthropogenic impacts on the environment and results in changes in biodiversity that are directly or indirectly caused by humans, and which have various negative effects on the environment. Managing and modifying the environment in accordance with the modern needs of society causes more harmful consequences than ever before. Anthropogenic influences differ greatly when it comes to urban and rural areas specific to the Republic of Serbia.

Anthropogenic factors that affect water quality include various activities within agricultural and industrial activities but also activities within the household. This way, elevated concentrations of heavy metals, mercury, coliforms, and nutrients can be observed in wastewater [6].

Anthropogenic factors that affect water quality in rural areas differ from those in urban areas. In rural areas, they usually include agricultural practices, for example, the use of fertilizers, herbicides, and pesticides, and animal husbandry. Anthropogenic factors that affect water quality in urban areas mainly include industrialization and the inadequate treatment of wastewater. Most discharged wastewater in the industrial sector includes the following sectors according to the Classification of Activities in the following order: mining, the processing industry, electricity, gas, and steam supply [7].

Chemical pollutants refer to substances that are toxic to flora, fauna, and humans and are present in nature in concentrations high enough to harm the environment and human health in general. Examples of pollutants that are known and can be found in water are numerous and diverse. The list may include nitrates, phosphates, detergents, pesticides, and other crop chemicals, chlorinated solvents, as well as metals (lead, mercury, chromium, cadmium, arsenic), dyes, organic matter (benzene, bisphenol), mineral-derived substances (arsenic and cyanide) and microorganisms (bacteria and viruses). Other pollutants are not well known but are also considered very dangerous, such as Volatile Organic Compounds (VOCs), Polycyclic Aromatic Hydrocarbon (PAH), Polychlorobiphenyls (PCBs), Brominated flame retardants, phthalates, and many others [8].

One way to measure water quality is to take samples from it and measure the concentrations of various substances it contains, using analytical techniques such as Inductively Coupled Plasma (ICP) for metals and/or determining chemical indicators or global parameters [5].

Before any measures are taken to reduce and/or remove any chemical, it is necessary to identify all the solutes. Water pollution can be manifested as: uneven mixture, color, unpleasant odor, the content of Suspended Solids (SS), the content of insoluble liquids (oils, fats, hydrocarbons), soluble and/or biodegradable molecules, substances that can give water redox potential, and problems with acidity or pathogenicity [9].

In this case, the quality of wastewater can be determined using physical, chemical and biological characteristics, or general parameters.

Physical parameters may include, for example, color, temperature, solids, turbidity, odor, oil, and grease. Solids can be further classified into insoluble and soluble substances, as well as organic and inorganic fractions.

Chemical parameters associated with the organic content of industrial wastewater include Chemical Oxygen Consumption (COD), Biochemical Oxygen Demand (BOD), Total Organic Carbon (TOC), and Total Oxygen Demand (TOD). Inorganic chemical parameters include pH (acidity/alkalinity), salinity, metals, sulfates, chloride, phosphorus, nitrogen, etc.

The two basic parameters of water quality include BOD and COD. BOD refers to the amount of oxygen required by various microorganisms in a water sample to oxidize substances in water, at a temperature of 200 °C, during a specific incubation period. In the analytical sense, BOD is the mass concentration of dissolved oxygen that is consumed for the biochemical oxidation of organic and partly inorganic substances in water. The standard method defines the incubation time as a period of 5 days, which determines the BOD<sub>5</sub>. Determining the BOD helps determine the degree of wastewater

pollution, but also tests how efficient the treatment plants are. There is a consensus that oxygen consumption is usually determined after 5 days (BOD<sub>5</sub>), although not all organic substances are oxidized in that period.

COD is the amount of oxygen that is equivalent to the dichromate consumed in the oxidation of organic matter and the oxidized part of inorganic matter in a certain volume of surface or wastewater that is tested. This parameter can be considered as an approximate measure of theoretical oxygen consumption, ie. as the amount of oxygen consumed in the complete oxidation of organic components into inorganic products [8].

Legislation covering industrial pollutants is becoming increasingly stringent today, especially in more developed countries, which, through regulations, imposes the treatment of wastewater and its discharge into the environment. Currently, European water policy stems from the Water Framework Directive, 2000 (WFD), which establishes guidelines for the protection of surface water, groundwater, and coastal water in Europe [5]. The WFD has also classified chemicals into two main lists of priority substances. The first, the so-called "Black List", includes Dangerous Priority Substances (DPS) that are considered to be persistent, highly toxic, or can lead to bioaccumulation. The second list, the so-called "Gray List", classifies Priority Substances (PS) that pose a significant risk to the environment. The classification of these substances can be based either on individual substances (eg metals, chlorobenzene, alkylphenols, etc.) or based on the industrial sector (eg agri-food industry, chemical industry, metal processing industry, etc.).

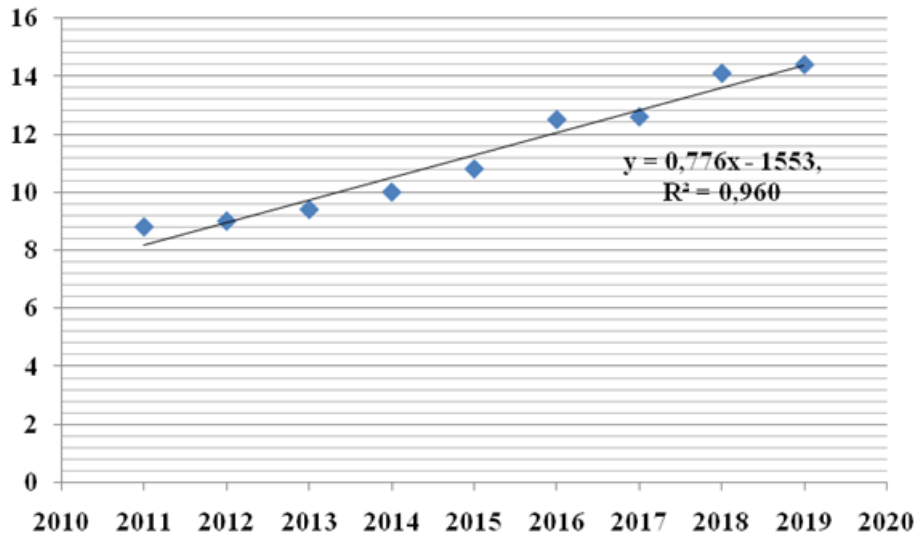
Today, modern Europe requires various industries to reduce and/or eliminate the discharge of DPS and PS chemicals into its wastewater. Wastewater treatment is beginning to receive active attention from the industrial world in the context of sustainable development (eg environmental protection, development of green chemistry concepts, use of renewable resources), improved water management (so-called "wastewater recycling") and health problems [10]. Therefore, efficient wastewater treatment has become a priority for the industrial world.

## **MATERIAL AND METHODS**

This research consist both - quantitative and qualitative method. The quantitative data were used from Statistical Office of the Republic of Serbia and NALED's Report, in order to represent the data of the analysis. The data were analyzed in Excel using trend lines with addition of coefficient of determination ( $R^2$ ) in order to give quantitative conclusions of the research. On the other hand, the logical induction was used in this research as a main qualitative tehniqe on. Logical induction is a method in which the data is synthesized in order to arrive at a general principle of the percieved data.

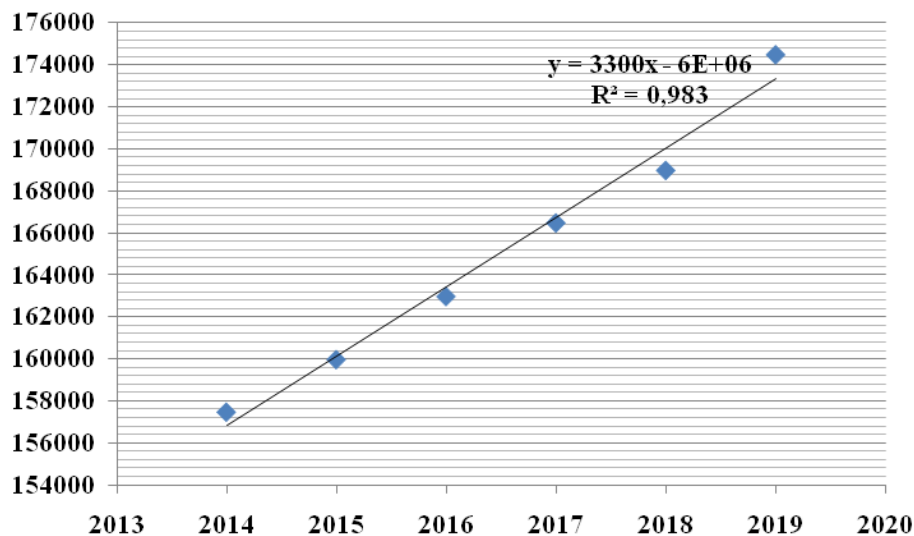
## **RESULTS AND DISCUSSION**

According to the analysis of wastewater management, it is stated that, in our country, less than 8% of municipal wastewater is treated before being discharged into the environment, which is attributed to outdated technology and plants that have been used for treatment for more than three decades [11]. In spite of this, Fig. 1 shows a clear positive growth trend in the percentage of the population who were connected to the wastewater treatment system, with a positive forecast of a 9.6% variance for the period from 2011 to 2019.



**Fig. 1.** Percentage of population connected to municipal wastewater treatment for the period 2010-2019.

The Republic of Serbia recorded a positive trend, with a coefficient of determination of 9.8% regarding the development of the sewerage network for the period from 2014 to 2019 (Fig. 2). According to statistics, about 65% of the Serbian population is connected to the sewerage system. Despite this positive trend a large percentage of the population, mainly from rural areas, still uses septic tanks, which significantly distorts the image of sewerage development. This less-than-ideal image is also one of the most important preconditions for the construction of an adequate water collection system, which isn't the case, according to the data. Thus, the sewerage network adequately covers municipalities, which are characterized by adequate collection, while for rural areas this is not the case. As a consequence of the generally low wastewater collection, there is a load placed on watercourses by wastewater with a high content of toxic substances, based on the frequency and their maximum allowable concentration.



**Fig 2.** Total length of the sewerage network in the Republic of Serbia (km) for the period 2013-2019

Table 1 provides an overview of the discharged and treated wastewater according to the type of treatment used in the Republic of Serbia for the period from 2012 to 2018. Based on the presented data, a slight, declining trend of discharged wastewater can clearly be seen when it comes to districts, municipalities with public sewerage, and households, while the numbers are increasing when it comes to other users. On the other hand, when it comes to wastewater treatment, the primary and secondary

treatment systems are quite scattered, while a slight, almost imperceptible progress can be seen in the tertiary treatment system.

**Table 1.** Discharged and treated wastewater according to the type of treatment for the territory of the Republic of Serbia for the period 2012-2018 (presented in thousands of m<sup>3</sup>)

<b>Discharged wastewater</b>	<b>2012</b>	<b>2013</b>	<b>2014</b>	<b>2015</b>	<b>2016</b>	<b>2017</b>	<b>2018</b>
Wastewater from districts <sup>1</sup>	431.052	430.882	397.553	408.208	393.269	409.046	403.746
Wastewater from municipalities with public sewerage	309.949	302.375	295.483	295.542	283.216	294.090	292.628
From households	221.530	215.926	216.777	215.283	209.818	216.649	214.083
From the industrial sector <sup>2</sup>	50.235	44.292	41.859	38.310	39.455	32.420	31.270
Other users <sup>3</sup>	38.184	42.157	36.847	41.949	33.943	45.021	47.329
<b>Treated wastewater</b>	<b>47.545</b>	<b>48.361</b>	<b>45.184</b>	<b>45.126</b>	<b>47.244</b>	<b>49.326</b>	<b>49.000</b>
Primary treatment	5.200	5.916	5.096	4.733	4.829	4.768	5.000
Secondary treatment	36.307	36.898	34.557	34.629	33.532	35.072	34.000
Tertiary treatment	6.038	5.456	5.531	5.764	8.883	9.486	10.000

<sup>1</sup>Total wastewater discharged into public sewers and septic tanks. Atmospheric water is not included.

<sup>2</sup>Wastewater discharged into public sewers.

<sup>3</sup>Discharged wastewater from business entities in the fields of agriculture, forestry, fishing, from hospitals, schools, institutions, shops, and other business entities and water for personal consumption are included.

Table 2 shows the distribution of discharged untreated and treated wastewater by river basins (presented in thousands of m<sup>3</sup>). According to the data, the largest basins, such as the Danube, Sava, and Great Morava, are also considered the most endangered. However, the load on the river basin must also be taken into account, ie. the relationship between the natural capacity of the watercourses and the amount of wastewater discharged. Completely untreated wastewater is discharged into rivers such as Lim, Mlava, and Pek, while the Danube is the only river that uses all three treatment systems before discharge.

**Table 2.** Distribution of discharged untreated and treated wastewater by river basin (presented in thousands of m<sup>3</sup>)

<b>Basin</b>	<b>Total discharged wastewater</b>	<b>Discharged untreated wastewater</b>	<b>Discharged treated wastewater</b>			
			<b>In total</b>	<b>Primary treatment</b>	<b>Secondary treatment</b>	<b>Tertiary treatment</b>
In total	294.090	244.764	49.326	4.768	35.072	9.486
Drina	4.952	4.852	100	100	0	0
Danube	131.566	122.843	8.723	321	8.279	123
Ibar	10.233	5.928	4.305	4.305	0	0
South Morava	14.532	11.895	2.637	0	2.637	0
Kolubara	8.528	4.257	4.271	0	4.271	0
Lim	2.286	2.286	0	0	0	0
Mlava	407	407	0	0	0	0
Nisava	19.309	19.219	90	0	34	56
Pek	576	576	0	0	0	0
Sava	41.366	37.359	4.008	0	189	3.819
Tamis	67	25	42	42	0	0

---

Timok	5.111	4.943	168	0	168	0
Tisa	8.602	2.105	6.498	0	1.231	5.266
Vardar	507	285	222	0	0	222
Great Morava	27.185	11.383	15.802	0	15.802	0
West Morava	18.862	16.401	2.461	0	2.461	0

## CONCLUSION

Due to limited water resources, wastewater treatment is a necessity today. Municipal and industrial wastewater represents one of the biggest modern environmental challenges in the Republic of Serbia. Since the environment, as a specific medium that reflects the consequences of all human activities, it must be viewed in the context of the general social and economic situation. It is necessary to find the best way to integrate it into the policies of other industries, in order to achieve sustainable development goals and gradually address the problems that have accumulated. Several factors affect the level and efficiency of environmental protection measures. Among them, when it comes to municipal and industrial wastewater, professional and financial capacities, planning and project documentation, legislative framework, as well as the interests of other industries are of notable importance.

For decades, not enough attention has been paid to the appropriate treatment of wastewater, through the construction of sewerage networks, collectors, and treatment plants, so the pollution of watercourses, groundwater, and soil has become unfavorable.

According to the 2020 report for Chapter 27, it is stated that when it comes to water quality, weak to moderate compliance with legal regulations has been achieved and still the biggest problem of pollution originates from untreated wastewater, especially when it comes to wastewater originating from the industrial sector because it is often released into the environment without any control or any form of treatment.

The amount of municipal wastewater in the Republic of Serbia has been estimated in most cases so far, but the high variability of data when it comes to the number of municipal wastewater treatment plants, as well as the data on their functionality, is problematic, and this can be attributed to different methodologies in estimating this data. Therefore, there is no exact system for assessing and controlling wastewater data, on the basis of which the existing situation would be assessed, and after which desired conditions and future tendencies would be assessed.

The level of development of treatment and sewerage systems in the Republic of Serbia is far behind European standards and requirements. When it comes to the harmonization of domestic legislation with European regulations, there is a lot of progress, and more active participation of the state in its implementation is expected.

One of the basic preconditions for successful wastewater management is the existence of appropriate legislation. The 2010 Water Law and the accompanying bylaws defined the legal requirements for harmonization with EU regulations, and progress has been made in this process. One of the main goals of water protection is to significantly reduce the contamination of industrial and municipal wastewater. Despite the state's efforts to keep up with existing European trends in wastewater management, at least for now, the Republic of Serbia must make more of an effort to harmonize its legislation with EU directives. In addition to the improvement of infrastructure and technology for wastewater treatment, another important obstacle in the implementation of European laws and regulations is certainly the administration, which requires a significant increase in staff capacity, but also coordination within the institutions of the country.

## REFERENCES

- [1] Helmer, R., Hespanhol, I.: Water Pollution Control - A Guide to the Use of Water Quality Management Principles, WHO, pp. 1-39, 1997.



- [2] Rathoure, A.K., Dhatwalia, V., K.: Toxicity and waste management using bioremediation, IGI Global, Hershey, 2016.
- [3] Babić, B., Ljubisavljević, D., Đukić, A.: Prečišćavanje otpadnih voda, Beograd: Građevinski fakultet, pp. 288-326, 2004.
- [4] Veljković, N., Petrović, Z., Šotić, A., Cibulić, A.: Perspektiva primene evropske direktive o prečišćavanju komunalnih otpadnih voda u Srbiji, Voda i sanitarba tehnika, Vol.47, No.1, pp. 5-16, 2018.
- [5] Morin-Crini, N, Crini, G.: Eaux industrielles contaminées. PUFC, Besançon, 2017.
- [6] Khatri, N., Tyagi, S.: Influences of natural and anthropogenic factors on surface and groundwater quality in rural and urban areas, Frontiers in Life Science, Vol.8, No.1, pp.23-39.
- [7] Statistical Office of the Republic of Serbia, Available at <https://www.stat.gov.rs/en-US/vesti/20210506-otpadne-vode-iz-naselja-2020/?s=2501>.
- [8] Sharma, SK, Sanghi, R.: Advances in water treatment and pollution prevention, Springer, Dordrecht, 2012.
- [9] Crini, G., Badot P., M.: Sorption processes and pollution, PUFC, Besançon, 2010.
- [10] Khalaf, M., N.: Green polymers and environmental pollution control, CRC Press; Apple Academic Press, Inc, Oakville, 2016.
- [11] Krstović, S., Pokimica, N., Radović, T., Đokić, N., Lalović, B., Cvetić, P., Jovanov., M.: Stanje u oblasti upravljanja otpadnim vodama 360°, NALED, 2020.

## COMPOSTING OF WASTE WATER SLUDGE FROM TEXTILE INDUSTRY

Marko Rokvić<sup>1,2</sup>, Dejan Ubavin<sup>1</sup>, Maja Sremački<sup>1</sup>, Milan Milotić<sup>3</sup>, Zoran Čepić<sup>1</sup>

<sup>1</sup>University of Novi Sad, Faculty of Technical Sciences, Novi Sad, Serbia,

<sup>2</sup>Green Group, Bačka Palanka, Serbia

<sup>3</sup>University of East Sarajevo, Faculty of Transport and Traffic Engineering, Doboj, Bosnia and Herzegovina

e-mail: [markorokvic@gmail.com](mailto:markorokvic@gmail.com)

**Abstract:** The paper represents a possible treatment solution for waste water sludge from textile industry. Waste from textile production is one of the most difficult streams of waste to manage, due to large variety of new materials and chemicals used. Textile production thus requires strong and robust waste management logistics, as well as waste water treatment. One of the problematic waste streams from textile industry is waste water sludge, which is currently being mainly taken to the unsanitary landfills. This “solution” is not a legal one, but due to lack of proper facilities it has become a default procedure for this waste type. In this paper, waste sludge is considered for composting. Results show that composting is possible, but with certain limitations.

**Key words:** composting, waste, sludge, textile

### INTRODUCTION

Composting is a process that optimizes the natural decomposition of food, garden, and agricultural wastes into a fertilizer-like product, called compost. It is a relatively low-cost strategy for converting the organics into a valuable material that can enrich the soil on farms, in parks and in household gardens.

The process of composting involves the breaking down of organic matter by microorganisms in the presence of oxygen. The volume of the organic waste can decrease by 60-90% as a result. Various composting methods are available depending on the amount of available land, the volume of organic material to be composted, a community's available budget, and the technical ability of those working at the facility.

Three types of composting operations are used to compost waste on a large scale. These operation types are aerated windrows, static piles, and in-vessel.

Aerated windrows are more suited to large volumes of organic material that are managed by power equipment used to turn the composting material periodically. Periodic turning re-aerates the windrows, promoting the composting process. In Serbia, only windrow composting is available.

Composting of waste sludge is a new challenge, due to different chemical composition of sludge, then other compostable materials. But it's a challenge that must be accepted, due to environmental benefits of the process [1].

### MATERIAL AND METHODS

#### Composting mechanism

Composting is accomplished by mixing an energy source (carbonaceous material) with a nutrient source (nitrogenous material) in a prescribed manner to meet aerobic microbial metabolic requirements.

The process is carried out under specific moisture and temperature conditions for a specified period of time. Correct proportions of the various ingredients are essential to minimize odours and to avoid attracting flies, rodents, and other small animals. For best results, operating temperature of the composting material should be 40 °C to 65 °C once the process has begun. The compost should maintain a temperature of between 40 and 65 °C for 5 days and maintain a temperature of 55 °C for a period of 4 consecutive hours during the five days. It should reach operating temperature within about 7 days and remain elevated for up to 14 days to facilitate efficient composting. The material should

remain at or above 40 °C for the remainder of the designated composting period. Lower temperatures may slow down the decomposition process, while higher temperatures can harm the bacteria aiding the de-composition process.

In addition to the time and temperature requirements, the finished compost must contain no sharp objects and must be sufficiently stable to be stored or applied to land without creating a nuisance, environmental threat, or hazard to human health.

The quality of the compost, and therefore its marketability, depends primarily on the quality of the feedstock. A single stream of organic waste, such as yard or garden waste, organic waste from produce markets or agricultural waste, rather than mixed municipal solid waste (MSW), creates higher quality compost and reduces the likelihood of contamination by chemical compounds. It is not advisable to attempt to produce high quality marketable compost out of MSW, even if the waste contains a high volume of organic material.

The composting process occurs most rapidly if the material being composted has a carbon-to-nitrogen ratio of 30:1. Achieving this ratio generally involves balancing wetter, nitrogen-rich waste material (grass, food waste) with carbon-rich waste material (leaves, shredded wood, etc.).

Because of the odour potential, the question of where to site the facility is critical. Enclosed facilities can install a filtration system to eliminate most of the odour problems, but this increases the system over-all cost.

Another option is to isolate the facility from residential or commercial areas or to co-locate the operation at a landfill or wastewater treatment site. Composting facilities should not be located in flood-prone areas as floodwaters will ruin the quality of the final compost. Proximity to the feedstock material is very important, since waste transportation can easily drive up system costs. Alternatively, if composting is only being used for reduced disposal volume, it could occur at the landfill facility.

Leachate is liquid produced from the decomposing waste that could be potentially hazardous. It will be generated even in well-run facilities. Outdoor sites (without protective roofing) will generate large volumes of leachate, due to precipitation. Paved flooring and a drainage system leading to a leachate tank or a wastewater treatment system can lessen this problem but they can dramatically increase the capital costs of a facility. Leachate can be reused on-site to maintain an appropriate moisture level in the pile or windrow. Poor leachate or storm water management can lead to water pollution, cause odours, and create a breeding ground for mosquitoes and other insects or pests. [2]

### **Market for compost and product certification**

Common consumers include farmers, landscapers and municipalities who can use the compost for agriculture, parks, schools, and public areas. Municipalities are the customers with the greatest control. Other small, high-end markets can also potentially exist. While no one will buy low-quality compost, good quality compost is not enough to guarantee a market. Attempting to sell poor quality compost can undermine attempts to create a market so it is important that careful consideration is given to quality control and marketing.

Decision makers should be aware of negative attitudes towards compost produced from municipal solid waste because it is bulky and perceived as waste material or because the economic benefits to agriculture and sustainable land management are not well-known. Many operators offer compost quality assurance by having a third-party vendor or review system test the quality of the product and certify it to build trust.

### **Case study**

For the purpose of this paper, one bigger textile factory was chosen, with cca 50 t/month of waste sludge.

The company is located in northern part of Serbia, and it is a factory for weaving, dyeing and textile finishing.

Because of the dyeing process, waste water treatment facility is operational, with daily generation of waste water sludge.

Waste analysis is given in Table 1. It has been performed by Institute of Occupational Safety AD Novi Sad, number of the report 02-5382/1 [3].

**Table 1.** Waste sludge analysis [3]

<b>The parameters</b>	<b>Values</b>
EWC code	19 08 14
Moisture content	86.64 %
Total carbohydrates C4-C10	19501.78 mg/kg SM
PCB <sub>tot</sub>	0.38 mg/kg SM
PAHs	< 0.1 mg/kg SM
pH	8.39

In the same analysis, evaporation of the sample has been done, giving following results, shown in Table 2.

**Table 2.** Waste sludge analysis after evaporation [3]

<b>The parameters</b>	<b>Values [mg/kg SM]</b>
Rest of the vapour	11400
Soluble organic carbon	4840
Sulphates	1096.3
Chlorides	2887.4
Sulphides	< 1
Ammonia	109
pH	8.39

An important criterion of the utilization of sewage sludge is the dose of the sludge per area unit. The determination of suitable doses is difficult and the following factors must be taken into account:

- quantity of nutrients (especially nitrogen);
- quantity of soil - forming organic matter (humus);
- admissible contents of heavy metals in brought, fertilized or reclaimed soils;
- contents of heavy metals in the sludge intended for fertilization or reclamation

Composting and environmental use of sewage sludge is classified as waste-free technology [4].

Process of collecting of waste sludge is using IBC containers, with their top cut off. 20 IBC is places on the facility. When they get full, truck collects them, simultaneously dropping off 20 empty IBC.

## RESULTS AND DISCUSSION

The carbon-to-nitrogen ratio of 30:1 needed for composting, and in the analysis it is shown that in the waste sludge ratio is 10:1. Complementary and significant parameters are moisture content, which is significantly higher than needed for composting, and presence of sulphates, and chlorides. Waste sludge composting requires significant amount of dry matter, so that moisture content can be lowered. Second part is adding amount of nutrient rich with nitrogen (green waste). Waste sludge does not help composting process, and it can take longer time for compost to be finished. After composting, new analysis is necessary. From this point of research, probably the use of this compost is not recommended for agriculture, rather for landfill daily cover, lawns, and reclamation of land. Leachate must be recovered and tested for composition. Testing compost material for carbon, nitrogen, moisture, and pH should be done if compost fails to reach desired temperature or if odour problems develop. The finished compost material should be periodically tested for constituents that could cause plant phytotoxicity as the result of application to crops. Composted materials that are prepared for the retail market may require testing for labelling purposes.

Not all composts are created equal. What goes in as feedstock partly determines what comes out. Compost quality depends on the composting process used, the state of biological activity, and, most importantly, the intended use of the compost. The end use defines compost quality.

There are some specific chemicals, physical and biological parameters that can be used to evaluate compost quality. For on-farm use as a soil amendment, a moisture content, organic matter content, C:N ratio and pH should be determined before compost application. High value markets like nurseries,

landscaping, and turf require a high quality compost with specific qualities and characteristics suitable for plant growth [5].

## **CONCLUSION**

Composting of waste water sludge is possible, considering that the waste sludge is not the best nutrient for composting. Possibly better option is for biogas production. Cost analysis should be also taken into account, when choosing the best option. Cost of composting is significantly lower than biogas production. Either option is better than landfilling. Sludge management should be developed towards great environmental utilization and this is possible with a gradual decrease of the storage on municipal dumping sites. Low technology composting can be a probable and economically beneficial solution for waste water sludge. The compost needs to be tested after process, and should avoid its use for gardening, especially organic.

## **ACKNOWLEDGMENT**

This paper has been supported by the Ministry of Education, Science and Technological Development through the projects no. 451-03-68/2020-14/200156.

## **REFERENCES**

- [1] Silpa K., Perinaz B., Decision Maker's Guides for Solid Waste Management Technologies - Composting, World Bank, Washington, DC, Technical Paper, 2018.
- [2] Composting facility guidance, Utah Division of Solid and Hazardous Waste Solid Waste Management Program, Solt Lake city, 2012.
- [3] Institut for occupational health: Waste sludge analysis report, 02-5382/1, 2015.
- [4] Kosobucki P., Chmarzyński A., Buszewski B.: Sewage Sludge Composting, Polish Journal of Environmental Studies Vol. 9, No. 4, 243-248, 2000.
- [5] Cooperband L., The Art and Science of Composting, Center for Integrated Agricultural Systems, Technical paper, 2002

## ASSESSMENT OF MUNICIPAL SOLID WASTE GENERATION IN THE MUNICIPALITIES OF AVEIRO DISTRICT USING ANOVA (ONE WAY) ANALYSIS

Nikola Karanovic<sup>1</sup>

<sup>1</sup>University of Aveiro, Portugal

e-mail: [nikolakaranovic@ua.pt](mailto:nikolakaranovic@ua.pt)

**Abstract:** Solid waste generation has been encouraged by rapid increase in population, changes or improvement in wages, massive expansion of the urban areas and the changing lifestyle or better standard of living as well as improvement in technology. Portugal is facing multiple problems with municipal solid waste (MSW) management and is attempting to tackle them by passing legislation in order to improve the performance of waste management systems. Portugal generated around 5.5 million tonnes of MSW in 2010, and the treatment is still heavily based on landfilling process. This aim of this work is to assess municipal solid waste generation in certain municipalities of Aveiro using ANOVA (one way) analysis by comparing 3 year data sets (data sets from 2011-2014). In this work, it is performed one way ANOVA analysis to determine whether there are any significant differences between the means of four independent (unrelated) groups. The one way analysis of variance (ANOVA) is used to determine whether there are any significant differences between the means of two or more independent (unrelated) groups. The management of municipal solid waste would have to involve detailed study of the characteristics of waste as the variation in waste type and composition, environmental impact, covering all the processes within the waste management system.

**Key words:** municipal solid waste, statistic, ANOVA

### INTRODUCTION

Solid waste generation has been encouraged by rapid increase in population, changes or improvement in wages, massive expansion of the urban areas and the changing lifestyle or better standard of living as well as improvement in technology [1]. Increase in population and income brings about an increase in production of goods and services and thus effluents are discharged into the environment. According to Ita (2003), waste can be defined as any material lacking direct value to the producer and so must be disposed of [2]. Similarly, waste is any material that is thrown away as unwanted [3]. It can also be defined as the organic and inorganic waste materials produced by households, commercial and industrial establishment that have no economic value to the owner [3].

Portugal is facing multiple problems with municipal solid waste (MSW) management and is attempting to tackle them by passing legislation in order to improve the performance of waste management systems. The country has made substantial progress in the waste domain from the situation that existed at the end of the last century when depositing in open dumps was the dominant (if not exclusive) treatment method. Portugal has an average level of waste generation compared to other European Union (EU) countries (514 kg/cap in 2010). Waste management is currently dominated by landfilling, but Portugal has invested in many other treatment options including incineration, composting and mechanical biological treatment (MBT) technology [4].

The drivers behind the developments in MSW include the national legislation, which predominantly transposes the EU Directives, and the National Waste Management Plans (PERSU). There have been two PERSU's in Portugal: PERSU I was ratified in 1997 and covered the period until 2006, when PERSU II came into play which targeted the period 2007-2016. PERSU I set both quantitative and qualitative targets for Portugal's MSW management system following in parallel the developments at the EU level.

The main objective of the PERSU I was to eliminate open dumps and divert the waste, according to specific quantified targets, to recycling, incineration and composting. This has been a difficult task, as in 2001, more than 340 dumps were yet to be closed [5]. Despite the plan's success in eradicating the open dumps, most of the targets set were not achieved [6]. Therefore, by taking into account the need to modernize the MSW system, PERSU II was ratified in 2006.

PERSU II aims to eliminate inefficiencies observed in the implementation of the previous plan:

- Adapt EU legislation to Portuguese reality.
- Rationalize the costs.
- Encourage participation of all stakeholders, based on input from all of them.
- Support incineration with energy recovery and MBT as solutions to MSW treatment.
- Introduce separate collection of organic wastes and other measures to divert them from landfills.
- Maximize by-products utilization.

The quantitative targets included in PERSU II are adopted from EU legislation. Besides the general frameworks such as PERSU, there are various other decrees regulating specific waste streams or treatment options [7]. In Portugal, the Ministry of the Environment is responsible for all waste legislation. The organization of the waste management system involves three other types of organizations [5]:

- Municipalities which are responsible for collection of (normally only mixed) waste.
- SGRSU which are entities dealing with waste treatment.
- SPV which is the Portuguese “Green Dot System” responsible for recycling packaging waste.

Portugal generated around 5.5 million tonnes of MSW in 2010, and the treatment is still heavily based on landfilling process. In the decade from 2001 to 2010, landfilling remained the dominant option with more than 60% in all years, but with a decreasing trend. This is mainly due to recycling which has steadily increased to 12% in 2010. Incineration covers around 20%, while the rest is composted. The following indicators illustrate the development of the Portuguese MSW management between the years 2001-2010. Figure 1 shows the development of MSW generation per capita in Portugal from 2001 to 2010. There is a slow increase throughout the years 2002 to 2010 from 443 kg per capita in 2002 to 514 kg per capita in 2010. There is a break in series in 2002, when the data collection method was changed: the statistical survey was replaced with administrative data sources. For 2001, the figure shows the amount of municipal waste collected. In 2001, 99 % of the population was covered by a municipal waste collection scheme; thus, the amount is slightly underestimated [4].

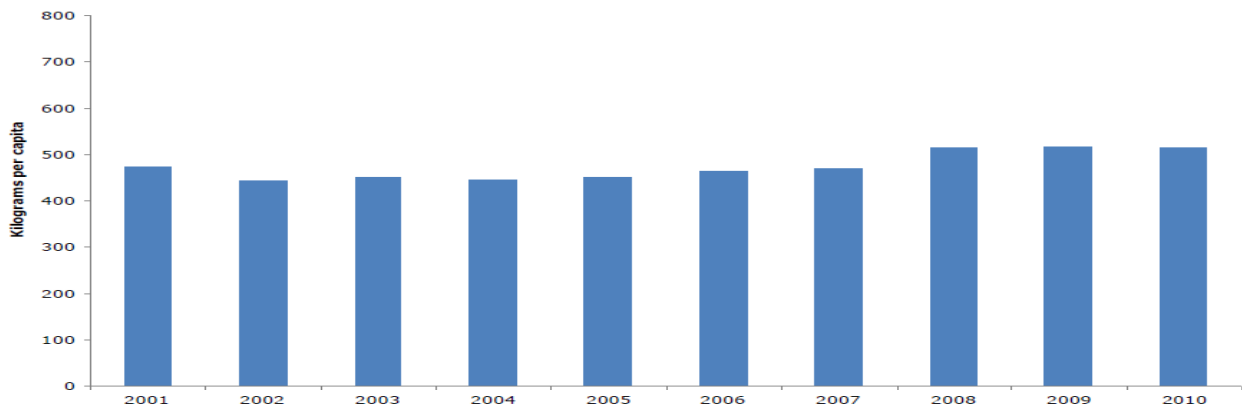


Fig. 1. MSW per capita in Portugal (in kg) [8]

This aim of this work is to assess municipal solid waste generation in certain municipalities of Aveiro using ANOVA (one way) analysis by comparing 3-year data sets (data sets from 2011-2014). Aveiro District is located in the central coastal region of Portugal. Municipalities from Aveiro district which will be the subject of this study are Agueda, Albergaria-a-Velha, Aveiro, Ilhavo, Oliveira do Bairro, Vagos, Arouca, Oliveira de Azemeis, S. Joao da Madeira, Vale de Cambra, Estarreja, Murtosa, Ovar and Sever do Vouga.

## METHODOLOGY

In this work, it is performed one way ANOVA analysis to determine whether there are any significant differences between the means of four independent (unrelated) groups. The one way analysis of variance (ANOVA) is used to determine whether there are any significant differences between the means of two or more independent (unrelated) groups. It is important to realize that the one way ANOVA is an *omnibus* test statistic and cannot tell you which specific groups were significantly different from each other, it only tells you that at least two groups were different. Since you may have three, four, five or more groups in your study design, determining which of these groups differ from each other is important [9].

Source for the data obtained in this work is ERSUC company. The ERSUC (resíduos sólidos do centro) is the company responsible for management and value the solid waste produced in 36 municipalities of the central coast of Portugal, favoring the improvement of quality of life and the environment. The ERSUC covers an area of 7000 km<sup>2</sup> (7.9% of the country), serves a population of approximately one million inhabitants and is about 430000 tonnes of waste per year [10].

Summary statistics were calculated for 14 municipalities, over the period from 2011-2014. In the tables are presented results of generated MSW per capita. ANOVA analysis was used to determine if there are statistically significant differences in the data based variables such as differences of generated MSW depending on the year. For the 2014 year it was taken the same number of inhabitants like it was in 2013 year, because the last census was in 2013.

The work includes:

- Data acquiring from ERSUC (“resíduos sólidos do centro”) concerning MSW generation in certain municipalities of Aveiro district,
- Applying ANOVA (one way) analysis and presenting the results of generated MSW per capita in certain municipalities of Aveiro district and its significance,
- Presentation of generated MSW per capita in certain municipalities of Aveiro district.

## RESULTS

From obtained results, as presented in Table 1, which it is possible to conclude that in the most municipalities which are observed in this study, there is no statistical significance in generation of municipal solid waste for period 2011-2014, except for the municipalities of Agueda, Albergaria-a-Velha, Aveiro, San Joao da Madeira.

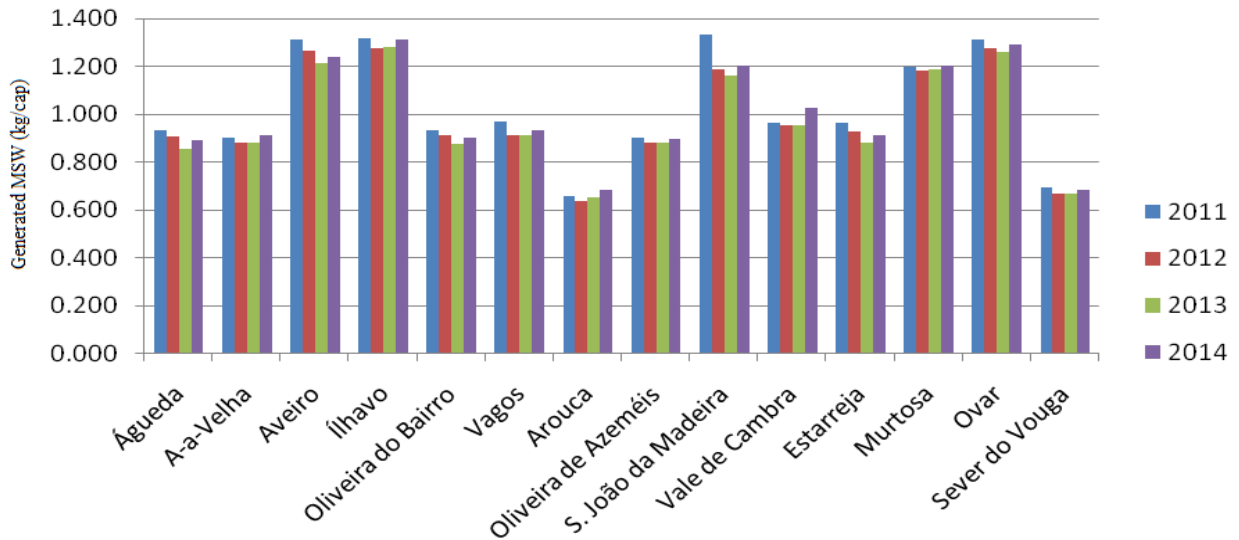


**Table 1.** Results of ANOVA analysis

<i>Municipality</i>	$\alpha$	<i>F</i>	<i>P-value</i>	<i>F crit</i>	<i>Comment</i>
Águeda	0.01	7.921614	0.000248	4.260643	Significance
	0.05	13.62473	4.86E-05	3.284918	
	0.1	7.921614	0.000248	2.212688	
A-a-Velha	0.01	6.522101	0.000955	4.260643	Significance
	0.05	6.522101	0.000955	2.816466	
	0.1	6.522101	0.000955	2.212688	
Aveiro	0.01	9.170162	7.9E-05	4.260643	Significance
	0.05	9.170162	7.9E-05	2.816466	
	0.1	9.170162	7.9E-05	2.212688	
Ílhavo	0.01	0.205268	0.892205	4.260643	No significance
	0.05	0.205268	0.892205	2.816466	
	0.1	0.205268	0.892205	2.212688	
Oliveira do Bairro	0.01	2.037029	0.122497	4.260643	No significance
	0.05	2.037029	0.122497	2.816466	
	0.1	2.037029	0.122497	2.212688	
Vagos	0.01	0.599754	0.618591	4.260643	No significance
	0.05	0.599754	0.618591	2.816466	
	0.1	0.599754	0.618591	2.212688	
Arouca	0.01	0.714406	0.548658	4.260643	No significance
	0.05	0.714406	0.548658	2.816466	
	0.1	0.714406	0.548658	2.212688	
Oliveira de Azeméis	0.01	0.359463	0.782543	4.260643	No significance
	0.05	0.359463	0.782543	2.816466	
	0.1	0.359463	0.782543	2.212688	
S. João da Madeira	0.01	16.06217	3.4E-07	4.260643	Significance
	0.05	16.06217	3.4E-07	2.816466	
	0.1	16.06217	3.4E-07	2.212688	
Vale de Cambra	0.01	1.647374	0.192181	4.260643	No significance
	0.05	1.647374	0.192181	2.816466	
	0.1	1.647374	0.192181	2.212688	
Estarreja	0.01	3.114991	0.035625	4.260643	For $\alpha=0.01$ significance, for $\alpha=0.05$ and $\alpha=0.1$ no significance
	0.05	3.114991	0.035625	2.816466	
	0.1	3.114991	0.035625	2.212688	
Murtosa	0.01	0.013145	0.997909	4.260643	No significance
	0.05	0.013145	0.997909	2.816466	
	0.1	0.013145	0.997909	2.212688	
Ovar	0.01	0.384642	0.764574	4.260643	No significance
	0.05	0.384642	0.764574	2.816466	
	0.1	0.384642	0.764574	2.212688	
Sever do Vouga	0.01	0.507574	0.679096	4.260643	No significance
	0.05	0.507574	0.679096	2.816466	
	0.1	0.507574	0.679096	2.212688	

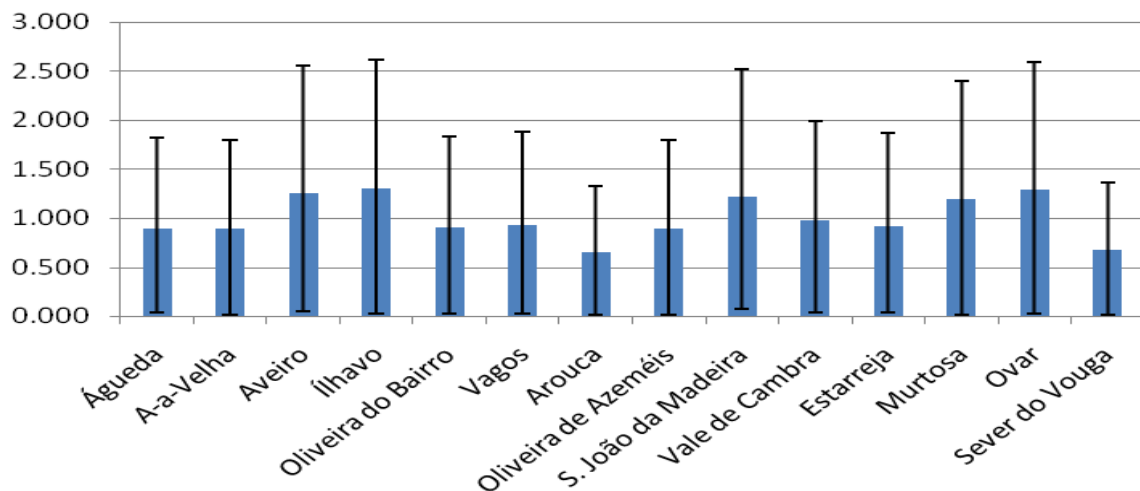
In the case of the municipality of Estarreja, there is a statistical significance in generation of municipal solid waste for  $\alpha=0.01$ , for  $\alpha=0.05$  and  $\alpha=0.1$  there is no statistical significance.

On the following figure, it is presented average generation of MSW per capita (in kg) which is the subject of the analysis.



**Fig. 2.** Average of generated MSW waste per capita

As shown on the Fig. 2, highest values related to the generation of MSW per capita are presented for the year 2011, and municipalities with highest contribution related to the generation of MSW per capita by analyzing period 2011-2014 are Aveiro, Ílhavo, S. Joao da Madeira and Ovar. Standard deviation is shown on Fig. 3.



**Fig. 3.** Standard deviation

## CONCLUSION

The conclusion drawn from this work is that the management of municipal solid waste would have to involve detailed study of the characteristics of waste as the variation in waste type and composition, environmental impact, covering all the processes within the waste management system. Consequently, a careful consideration of all these factors in relation to local conditions must be the basis of a sound and sustainable waste management plans.

## REFERENCES

- [1] UNICEF. (2001). Waste Disposal System. Sanitation and Policies Objective. World Health Report.
- [2] Ita, M. (2003). Waste is the developing world ready? Science in Africa. Africa's First Online Science Magazine. Science Magazine for Africa. MERCK.
- [3] UNICEF. (2006). Solid and Liquid Waste Management in Rural areas. A Technical Note.

- [4] European Environment Agency (EEA). (2013). Municipal Waste Management in Portugal. ETC, Copenhagen Resource Centre.
- [5] Magrinho, A., Didelet, F., Semiao, V. (2006). Municipal solid waste disposal in Portugal. Waste Management 26, 1477–1489.
- [6] Ribeiro, A., Castro, F., Macedo, M., Carvalho, J. (2011). Waste management in Portugal and Europe – An overview of the past, present and future. WASTES: Solutions, Treatments and Opportunities, 1st International Conference.
- [7] ETC/SCP. (2006). Waste Fact Sheets: Portugal in [http://forum.eionet.europa.eu/nrc-scp-waste/library/country\\_fact\\_sheets/portugalpdf](http://forum.eionet.europa.eu/nrc-scp-waste/library/country_fact_sheets/portugalpdf).
- [8] Eurostat. (2012): “Waste database municipal waste”  
<http://epp.eurostat.ec.europa.eu/portal/page/portal/waste/data/database>. Accessed 2021.
- [9] Cohen, H., B. (2002). Calculating a Factorial ANOVA from Means and Standard Deviations. Lawrence Elbaum Associates Inc, Understanding Statistics. New York University.
- [10] ERSUC. (accessed 2021). [www.ersuc.pt](http://www.ersuc.pt)

## HEALTH AND SAFETY RISKS AND CHALLENGES FOR WORKERS IN THE TONER CARTRIDGE RECYCLING PROCES

Stepan Polygalov<sup>1</sup>, Marko Rokvić<sup>2,3</sup>, Nemanja Stanisavljević<sup>2</sup>, Maja Sremački<sup>2</sup>, Zoran Čepić<sup>2</sup>

<sup>1</sup>Environmental Protection Department, Perm National Research Polytechnic University,  
Komsomolsky prospek 29, Perm, Russia

<sup>2</sup>University of Novi Sad, Faculty of Technical Sciences, Novi Sad, Serbia,

<sup>3</sup>Green Group, Bačka Palanka, Serbia

e-mail: [polyste17@mail.ru](mailto:polyste17@mail.ru)

**Abstract:** Large amounts of waste toner cartridges have been generated as a result of their use in printers and duplicators on an everyday basis. Waste toner cartridges contain heavy metals, plastics, as well as residual toner powder, and have been characterized as non-hazardous waste. Therefore, the management of waste toner cartridge content presents a significant issue in environmental protection. In Serbia, there are several small scale facilities that treat waste toner cartridges. This process has a number of different problems and challenges, and work safety is not among the priorities. In this work, the potential hazard on health and safety has been evaluated, so proper procedures could be created. One line for recycling has been chosen, others are slightly different, with no influence on the health and safety.

**Key words:** toner cartridge, recycling, health and safety, risks, safety measures

### INTRODUCTION

The demand for electrical and electronic equipment (EEE) has been increasing exponentially, due to urbanization, industrialization, and increasing population. Printers and cartridges constitute a significant source of e-waste despite the modern trend of digitalization. About one million printer cartridges are disposed every day on a global scale. Each cartridge contains about 8 % of unused toner by weight, amounting to the release of 6000 tons of carbon powder into the environment. Printer toners are an important part of electronic waste, mainly due to their limited operational life, resistance to degradation after disposal, and environmental and economic challenges in recycling/reuse. When disposed in landfills, they cause soil and water pollution leading to a multitude of health hazards. Negligence in the treatment, recycling, and reuse of toner waste is expected to create serious environmental issues in the near future. Considering the current global scenario and future issues, it is important to develop viable technologies for recycling and reuse of toner waste. In this context, the present review provides a comprehensive account of the challenges and emerging trends in the recycling and reuse of toner waste [1].

### MATERIAL AND METHODS

#### Waste toner cartridges treatment

Recycling of empty waste toner cartridge means that all usable parts after dismantling (iron, aluminium, and plastics) can be used again. The production line is mostly performed by manual labour. Screwdrivers, pliers, scalpels, etc. are used as tools - mostly hand tools. The machines use compressors for blowing air, as well as vacuum cleaners for dust removal and collection of waste toner powder, plastic crusher and extruder.

The production capacity of the observed plant is designed to process over 22000 used toner cartridges per month or about 20000 kg, which would amount to about 264000 used toner cartridges or about 240000 kg for a period of one year. The following wastes are generated from the production process:

- Waste plastics - parts of toner cartridges, EWC code 080399/191204
- Waste and scrap of aluminium, EWC code 080399/191203
- Wastes and scrap of iron and steel, EWC code 080399/191202
- Waste toner powder, EWC code 080318

- Solid waste from cleaning toner cartridges, EWC code 080399/150203
- Waste used filters from ventilation systems, EWC code 150203/191203

### Manual disassembly

Used waste toner cartridges for laser printers (black and white, colour) are delivered to the production plant. After the plastic cartridge is opened, manually on the workbench - the gears, magnets, cleaners, springs, springs, etc. are removed, using a hand tool, it is brought into the workstation for cleaning toner with a filter. There, the remaining used toner powder is emptied from the cartridge. The vacuum cleaner is hermetically connected to a metal container which is the final recipient of the powder used, and all together it represents a central dedusting system with filters.

Disassembly - the place where the largest amount of waste is generated is shown in Figure 1.



**Fig. 1.** Unfolding the toner cartridge [2]

Waste toner cartridges are opened and all consumable parts are removed. Hand tools are used - cordless screwdriver, screwdriver, pliers, etc.

### Vacuum cleaning

At this stage, residual toner powder is blown out of the tank and all plastic parts. A compressor machine is used for blowing, which has a suction part (Figure 2).



**Fig. 2.** Dedusting machine [2]

Cleaned plastic is being sent to crusher (Figure 3). The operator inspects each piece visually, and removes pieces that have not been sufficiently cleaned in the box next to the basket, as well as pieces that are not of the same type of plastic. If plastic types are mixed, the ground material will not meet the extrusion requirements, and therefore the regranulate will be of poor quality. Below the crusher is a sack for ground material. The jack is mounted by hand, before crushing. The amount of material in the bag is checked from time to time. When the sack is full, the crushing is stopped, and a new sack is placed. After replacing the bag, the crushing continues.



**Fig. 3.** Crusher [2]

After crushing, the ground material is inserted into the extruder (Figure 4), for further processing. The extruder heats the plastic up to its optimal melting point, then elongating the melted material in to long strips, which are being cooled down in water. The last part is cutting the straws to small pieces – regranulate.



**Fig. 4.** Noodles of plastic on the extruder [2]

### **Chopper**

The work of the chopper is inextricably linked with the work of the extruder and is an integral part of the process of production of plastic regranulates.

It is small shredder, and it is located at the end of the extrusion process and translates the plastic strips from the extruder into the form of granules. The strips pass through a bowl of water, where they are cooled, and enter the chopper. When starting the chopper (Figure 5), it is necessary to run the strips manually to the chopper with a tool. After that, the chopper pulls the strips itself.



**Fig. 5.** Strips of plastic on the extruder [2]

A bag for receiving granules is placed at the exit of the chopper. The regranulate is transferred to jumbo bags, and then stored in the warehouse. Each bag is placed on a pallet, stretched with foil and marked with a sticker with the type of material, colour and quantity. In this form it is sold as a finished product [2].

### **Health and safety risks in the production**

Several very dangerous points and less dangerous points can be identified:

1. Danger of inhalation of toner powder – The fine toner particles ( $>10\ \mu\text{m}$ ) may remain suspended in the air for significant period of time, which can cause the occurrence of certain negative health effects associated mostly with irritation and damage of the respiratory system. Because of the high molecular weight of the styrene acrylate copolymer, the main toner component is not readily biodegradable. Two of the ingredients in toner, carbon black and titanium dioxide, have been classified by the International Agency for Research on Cancer (IARC) as “possibly carcinogenic to humans” (Group 2B) [3].
2. Danger of explosion – Toner powder is not hazardous materials in the UN recommendations, but it is clear that toner powder is easy to make dust explosion. Evaluation tests were also conducted at the Research Institute of Safety and Engineering of Japan, and by Hiroshi Koseki, from Faculty of Risk and Crisis Management, Japan. Sample powders were new and recycled toner powder which was taken from the incident facilities in Hatano city, Japan. There is not large difference between both samples, but recycled one might be more dangerous than new one in regard to lower limit of dust concentration. In the near future, particle size will be smaller and will be more dangerous [4].
3. Physical injuries – workers may injure themselves while working on every part of treatment line. While using hand tools, injuries to the hand may occur. The biggest danger is on the chopper, while cleaning the unit. During operating on shredder, little pieces of plastic can be air born due to mechanical operation of shredding. This can injure eyes of the operator.
4. Noise – noise hazard is most present while using the shredder. The highest indicated noise levels emitted from crusher (95.2 dB(A)) were greater than the permissible noise exposure level of the Occupational Safety and Health Standards (90 dB(A)). The noise levels of other processes of the line were relatively safe. An acoustic hood was developed to reduce the noise levels of the crusher and the AMS. Then, the noise levels were both decreased to 67.6 dB(A). This paper provided important data for the environment on the industrialization of waste toner cartridges recovery.
5. Burns – extruder works on high temperatures, depending on the material up to  $250\ ^\circ\text{C}$ . The risks are great while cleaning the head of the extruder and changing the filters.

### **RESULTS AND DISCUSSION**

The measures that have to be applied in the working environment of the toner cartridges recycling process as a result of analysed process of operation, is as follows:

---

1. Noise reduction – an acoustic hood can be developed to reduce the noise levels of the crusher, and protective earplugs or headphones are mandatory.
2. Burning hazard – special gloves for high temperatures must be used.
3. Explosion hazard – better ventilation and all electrical installation must be in S type. All sources of sparks or heat must be isolated.
4. Aspiration hazard – face mask with filter has to be mandatory. Best possible ventilation of the working space must be provided.
5. Injuries – protective gloves and goggles are mandatory.

Besides using this type of equipment and precocious measures, obligatory has to be frequent training for the workers and operators. Safety check-up must be performed regularly.

## **CONCLUSION**

Toner cartridge treatment is necessary in sustainable waste management. Process of treatment in low and middle income countries, is usual at low technology level. This means that there are significant risks for workers. This is the case in Serbia, so it is necessary to take steps to prevent and lower these risks. Possibility of toner powder explosion is the highest priority for solving, thus the possible damage could be catastrophic on lives, and on equipment. Other risks, danger of inhalation, burning hazard and others can also cause severe injuries. Safety risks of waste toner treatment haven't been conducted by any regulatory body, and it is mostly unknown field for health and safety inspectors. This paper has shown the most significant risks, and countermeasures for preventing possible accident.

## **ACKNOWLEDGMENT**

This paper has been supported by the Ministry of Education, Science and Technological Development through the projects no. 451-03-68/2020-14/200156.

## **REFERENCES**

- [1] Anić Vučinića A., Vujević D., Mujkić K., Novak M.: Recycling of Waste Toner in the Republic of Croatia – An Environmentally Friendly Approach, *Chemical Engineering Transactions*, 34, 121-126, DOI:10.3303/CET1334021, 2013.
- [2] Rokvić M.: Waste toner cartridge treatment operation plan, Manual, Grand Group Holding, Bačka Palanka, 2015.
- [3] Yordanova D., Angelova S., Dombalov I.: Utilisation Options for Waste Toner Powder, *International Scientific Journal Environmental Science*, 2014.
- [4] Koseki H.: Study and countermeasure of hazard of dust explosion of various toner cartridges, *Procedia Engineering*, Nr 84, 273 – 279, 2014.



## BIOLOGICAL HAZARDS IN THE WORKING ENVIRONMENT DURING THE OPERATION OF THE ANIMAL WASTE INCINERATOR

Galina Ilinykh<sup>1</sup>, Sandra Kozomora Subotin<sup>2</sup>, Nemanja Stanisavljačić<sup>2</sup>,  
Maja Sremački<sup>2</sup>, Zoran Čepić<sup>2</sup>

<sup>1</sup>Environmental Protection Department, Perm National Research Polytechnic University,  
Komsomolsky prospek 29, Perm, Russia

<sup>2</sup>University of Novi Sad, Faculty of Technical Sciences, Novi Sad, Serbia

\*e-mail: [galina.perm.59@yandex.ru](mailto:galina.perm.59@yandex.ru)

**Abstract:** This paper is a review of biological hazards in the working environment during the operation of the small animal waste incinerator. This paper describes the subject plant, a real plant for incineration of animal carcasses and remains with small capacity and the organization of work and operations. The paper is portraying the method of testing biological hazards in the work environment throughout the operation process. Therefore, the biological hazards in air of workplaces were examined and the analyses for the presence of biological hazards on work equipment with which employees come into contact the most time were performed. The evaluation of the obtained results of the presence and type of biological hazards in the working environment and on the working equipment in the plant for incineration of animal carcasses and remains is presented in this paper.

**Key words:** biological hazards, animal carcass, incineration

### INTRODUCTION

The incineration of animal carcasses and remains throughout history is a very important activity for the disposal of animal waste, especially when it comes to large-scale epidemics in animals. Animal cadavers pose a danger both to the environment and human population, in the context of high potential for the spread of infectious diseases [9].

Frequently, animal carcasses are thrown on roads, agricultural grounds, and rivers, posing a variety of biological and environmental hazards. [1]. Corpses and remains of animal origin have to be considered as potentially infectious and dangerous material because they contain various microorganisms, some of which are zoonotic pathogens. The method of disposal has to be safe, practical and economical; and it is necessary to use a method that is vital for biosafety [8]. An effective way to dispose of animal carcasses is essential regardless of the cause of death, but perhaps the most important thing is to prevent the possible spread of infectious diseases. Rapid slaughter of animals and adequate disposal of animal carcasses and remains is the key part of the strategy for the eradication of infectious diseases.

Domestic animals can be infected with exotic diseases. There is a possibility of pandemics such as foot and mouth disease (FMD), bird flu (AI - avian influenza), and transmissible spongiform encephalopathy (TSE - transmissible spongiform encephalopathy), i.e. a group of progressive prion diseases that affect the brain and nervous system of animals and humans. These TSEs are also known as bovine spongiform encephalopathies (BSEs) or bovine mad cow disease; and chronic loss disease in deer or elk, also known as zombie deer disease. As a result of an outbreak or natural disaster, catastrophic mortality can occur. In case of disease outbreaks, animals within a certain area are removed and their safe care is required, which is practical and economically reasonable [2].

On the territory of the Republic of Serbia, there are 900 registered plants for meat processing and slaughter [10]. According to the gathered data, there are approximately 28000 t/year of animal carcasses and 245000 t/year of slaughterhouse waste [10]. Merely 20 % of animal carcasses and waste is processed in registered plants [10].

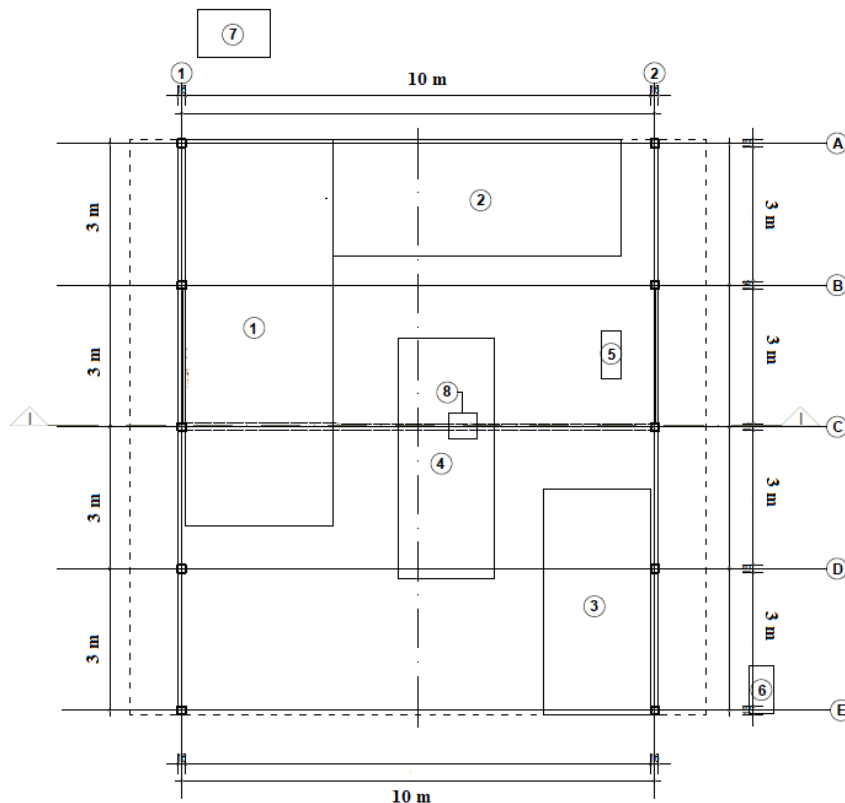
In Serbia, the incineration process is regulated, among other legislative documents, by the Ordinance on the manner of classification and handling of animal by-products [6] which defines incineration or burial in livestock cemeteries with the use of appropriate biosecurity measures to prevent the spread of infectious diseases during transport and processing, which, in accordance with the law governing veterinary medicine, are carried out under the supervision of the veterinary inspection. One of the measures of the veterinary inspection, in the process of providing the permits for the incineration

operations, is that the vigorous sanitary and hygienic procedures have to be carried out during the operation process in the plant.

## MATERIAL AND METHODS

### Description of the plant for incineration of animal carcasses and remains

The equipment for incineration of animal waste is located under the canopy; the dimensions of the canopy construction are 10 x 12 m, while the dimensions of the floor concrete floor are 12 x 12 m (Figure 1).



**Fig. 1.** Graphic representation of the position of incineration equipment: 1 – Cold Storage, 2 - Hygienic sanitary container, 3 - Office container, 4 - Incinerator INCINER8 Model I8-250 , 5 - Control panel for technical equipment in the incineration process, 6 – Fuel tank, 7 - Microbiological purifier, 8 – Crane

All of the equipment is located under the canopy except for the fuel tank and microbiological purifier that are placed next to the canopy, and in all respects according to the Figure 1.

INCINER8 Model I8-250 incinerator has a chamber capacity of 2.4 m<sup>3</sup>, and burns 150 to 400 kg of waste per hour (depending on the type, composition of waste and method of use) (Figure 2). The incinerator design allows direct loading of animal waste from above into the incineration chamber. The materials used in the production are high-quality refractory insulation coatings that enable maximum heat retention, i.e. minimize losses. The incinerator has the ability to incinerate waste at temperatures of over 1000 °C, for greater efficiency and complete combustion. This model has a robust secondary chamber for complete combustion of secondary pollutants from the combustion chamber emission at high temperatures.

At the analysed location, the processes of reception, temporary storage and treatment (incineration) of animal waste is performed. The plant is fenced with a wire fence that is fixed to the concrete. Within the building there are two separate rooms, one for workers with a changing room and a separate sanitary part (bathroom and toilet) which is separate from the part that opens into the work areas

(incinerator, refrigerator, etc.). There is also a porter's lodge to enter the facility. All traffic areas in the complex, i.e. manipulative plateaus, are concreted.

Measurement of animal waste is performed with livestock with a carrying capacity of at least 1000 kg. Manipulation of animal waste is done with the help of:

- 2 forklifts with a capacity of 1000 kg to 2200 kg,
- 2 electric cranes, one for animal waste and one for the incinerator lid,
- 2 mobile refrigerated containers.

During the operation of the plant, employees do not manually manipulation or have direct contact with the animal waste.



**Fig. 2.** Incinerator INCINER8 Model I8-250

The planned maximum daily intake of animal carcasses and remains is 400 kg, which is also the maximum storage capacity (cold storage). The types and quantities of waste treated in the incinerator are given in Table 1 in accordance with the Ordinance on categories, testing and classification of waste [4] in Serbia.

**Table 1.** Waste types, capacity, Q and R markings

Waste index number	Waste type	Q mark	Storage (t / year)		
			Installed capacity	Functional capacity	R mark
02 02 02	Waste from animal tissue	Q1/Q3/Q14	110	90	R 13

### Organization of work in the animal waste incineration plant

In the incineration plant there are several working positions:

- Drivers of refrigerated vehicles for the transport of animal waste,
- Operator of the incantation process for animal waste,
- Auxiliary workers in the incineration process.

Administrative and managing employees – director, manager and administrative workers – spend time in the office container. A tour and visual inspection of the plant is performed daily.

## Examination of working environment conditions - biological hazards

This paper examines the working environment conditions related to biological hazards in accordance with the regulations of the Law on Safety and Health at Work [3], the Ordinance on the procedure for inspection and verification of work equipment and testing of working environment conditions [7] and the Ordinance on preventive measures for safe and healthy work in exposure to biological hazards [5] used in Serbia. The biological hazard test was performed as a periodic test. During the test, all capacities were in use: work equipment, air conditioning installations, ventilation etc.

The instruments and devices used in the process of testing the working environment are:

- Laboratory instruments and materials
- Sterile swabs
- Active sampling device - air sampler MAS 100 Eco.

## RESULTS AND DISCUSSION

Biological hazards are tested in each work area, as well as on working equipment, in order to undertake an adequate assessment of the working environment conditions in terms of biological hazards.

### Testing of biological hazards in a sanitary container

The sanitary container during the incineration of animal waste serves for hygienic purposes and also has a room for workers to rest, with a wardrobe and showers. This area was selected for analyses and the measuring point is shown in Figure 3. The measurement of biological hazards was performed in accordance with the methodologies for testing of the working environment. Biological hazards in the air in the sanitary container were measured. The obtained results are presented in Table 2.



Fig. 3. Measuring point for sampling for biological hazards in a hygienic container in the workers' rest room

Table 2. Results of measurements of biological hazards in the air in a sanitary container

Biological hazards	Classification of biological hazards	
The presence of biological hazards in relation to the level of risk of infection	Group 1	<i>Staphylococcus epidermidis, Alternaria spp, Geotrichum spp, Cladosporium spp</i>
	Group 2	/
	Group 3	/
	Group 4	/

### Testing of biological hazards in an office container

The office container is used for administrative purposes; it has an office with two office desks and a toilet. The measuring point is shown in Figure 4.



**Fig. 4.** Sampling point for sampling for biological hazards in an office container.

The obtained results are presented in Table 3.

**Table 3.** Results of measurements of biological hazards in the air in an office container.

Biological hazards	Classification of biological hazards	
The presence of biological hazards in relation to the level of risk of infection	Group 1	<i>Staphylococcus epidermidis, Alternaria spp, Geotrichum spp</i>
	Group 2	/
	Group 3	/
	Group 4	/

### Testing of biological hazards in a vehicle for transporting animals waste

The vehicle for transporting animal waste is used to transport animal waste from the place of death to the incinerator; the vehicles are equipped with mini refrigerators in which animal waste is stored. The measuring points are shown in Figures 5 and 6.

The measurement of biological hazards was performed in accordance with the methodologies for testing the working environment. Biological hazards in the air in the vehicle for the transport of animal waste were measured and a swab of the work surface was made, i.e. a swab of the door handle (Figure 5 and 6).



**Fig 5 and 6.** Sampling points for biological hazards in the vehicle for the transport of animal waste, as well as on the vehicle itself (vehicle handle).

**Table 4.** Biohazards in the air of vehicles for the transport of animal waste

<b>Biological hazards</b>	<b>Classification of biological hazards</b>	
The presence of biological hazards in relation to the level of risk of infection	Group 1	<i>Staphylococcus epidermidis, Alternaria spp, Geotrichum spp</i>
	Group 2	<i>E. faecalis, S. aureus</i>
	Group 3	/
	Group 4	/

The results of measurements of biological hazards in the air are shown in Table 4, while the results of measurements of biological hazards obtained on the basis of swabs taken from the handle of the vehicle are shown in Table 5.

**Table 5.** Biohazards on the vehicle (handle) for the transport of animal waste

<b>Biological hazards</b>	<b>Classification of biological hazards</b>	
The presence of biological hazards in relation to the level of risk of infection	Group 1	<i>Staphylococcus epidermidis, Alternaria spp, Cladosporium spp, Bacillus subtilis</i>
	Group 2	<i>E. faecalis, S. aureus</i>
	Group 3	/
	Group 4	/

#### Biohazard testing on the refrigerator for animal waste storage

The cold storage is used for storage of animal waste. Animal waste is disposed of in a refrigerated transport vehicle before incineration. The sampling point is shown in Figure 7.



**Fig. 7.** Sampling point for sampling for biohazards on refrigerator

Biological hazards were measured using a swab from the handle on the refrigerator. The measurement results are shown in Table 6.

**Table 6.** Results of biohazards on refrigerator for storage of animal waste

<b>Biological hazards</b>	<b>Classification of biological hazards</b>	
The presence of biological hazards in relation to the level of risk of infection	Group 1	<i>Staphylococcus epidermidis, Aspergillus niger, Mucor spp, Cladosporium spp, Bacillus subtilis</i>
	Group 2	<i>P. aeruginosa, E. faecalis</i>
	Group 3	/
	Group 4	/

#### Testing of biological hazards on the control panel for crane of animal corpses

The crane in the process of work is used for the transfer of animal waste, which enables the transfer of animal corpses without direct contact of employees with the incineration material. The measuring point is shown in Figure 8.



Fig. 8. Sampling point for biohazards on the crane control panel

The measurement results are provided in Table 7.

Table 7. Results of biological hazard measurements from a swab taken from a crane switch

Biological hazards	Classification of biological hazards	
	The presence of biological hazards in relation to the level of risk of infection	Group 1
	Group 2	<i>P. aeruginosa, E. faecalis</i>
	Group 3	/
	Group 4	/

Group 1 biohazards are hazards that are unlikely to cause disease in humans, while group 2 biological hazards are hazards that cause disease in humans and can be dangerous to employees, unlikely to spread to the environment, and there are usually available effective prophylaxis measures [5].

## CONCLUSION

Working environment health and safety and adequate hygienic and sanitary (HSs) procedures are greatly important aspects, particularly in the procedures and operation of an animal waste incineration plant. The vigorous and precise HSs procedures will provide a biologically safe working environment. Considering the obtained results of measuring biological hazards, it is necessary to perform the prescribed hygienic and sanitary procedures on a daily basis, as well as to disinfect daily work equipment and surfaces that are in contact with animal waste. Also, it is necessary to provide employees with appropriate personal protective equipment and means in order to minimize the risk of negative health impacts of biological hazards.

Inspection of the biohazards in relation to the level of risk of infection should be carried out at least once every three years in accordance with the Ordinance on the procedure for inspection and verification of work equipment and testing of working environment conditions in order to have an insight into safe working conditions in terms of biological hazards and to implement adequate protective measures in context of the obtained results.

## ACKNOWLEDGMENT

This paper has been supported by the Ministry of Education, Science and Technological Development through the projects no. 451-03-68/2020-14/200156 and by the Government of Perm Krai, research project No C-26/174.6.

## REFERENCES

- [1] Ahuja, SM., Cost Effective Solution for Carcass Disposal in India, International Journal of Environmental Sciences, Vol.1, No.6, pp. 1–6, 2011.
- [2] Kim, G. and Pramanik, S., Biosecurity procedures for the environmental management of carcasses burial sites in Korea, Environmental Geochemistry and Health, Vol.38, No.6, pp. 1229–1240, 2016.

- [3] Law on Safety and Health at Work (in Serbia) ("Službeni glasnik RS", br. 101/05, 91/15 i 113/2017- drugi zakon).
- [4] Ordinance on categories, testing and classification of waste (in Serbia) ("Sl. glasnik RS", br. 56/2010, 93/2019 i 39/2021).
- [5] Ordinance on preventive measures for safe and healthy work during exposure to biological hazards (in Serbia) ("Sl. glasnik RS", br. 96/2010 i 115/2020).
- [6] Ordinance on the manner of classification and handling of animal by-products, veterinary-sanitary conditions for construction of facilities for collection, processing and destruction of animal by-products, manner of conducting official control and self-control, as well as conditions for cattle cemeteries and grave pits (in Serbia) (Službeni glasnik RS, 31/2011, 97/2013, 15/2015 i 61/2017).
- [7] Ordinance on the procedure for inspection and verification of work equipment and testing of working environment conditions (in Serbia) ("Službeni glasnik RS" broj 94/06, 108/06, 114/14 i 102/15).
- [8] Sakthivadivu, R., Sivakumar, K., Kumar, RSV., et al., Chemical Changes during Composting of Poultry Waste with Coirpith Waste and Sugarcane Top, *International Journal of Environment Science and Technology*, Vol.4, No.1, pp. 40–49, 2015.
- [9] Vučemilo, M. Zbrinjavanje životinjskih leševa i konfiskata. [Disposal of animal carcasses and confiscated material.], *Meso [Meat]*, Vol.6, No.4, pp. 52-57, 2004.
- [10] Waste management strategy for the period 2010-2019. years (in Serbia) ("Sl. glasnik RS", br. 29/2010).



## SAFETY AND HEALTH RISKS FOR WORKERS AT THE ANIMAL WASTE INCINERATION PLANT

Sandra Kozomora Subotin<sup>1</sup>, Stepan Polygalov<sup>2</sup>, Nemanja Stanisavljić<sup>1</sup>, Maja Sremački<sup>1</sup>, Zoran Čepić<sup>1</sup>

<sup>1</sup>University of Novi Sad, Faculty of Technical Sciences, Novi Sad, Serbia

<sup>2</sup>Environmental Protection Department, Perm National Research Polytechnic University,  
Komsomolsky prospek 29, Perm, Russia  
e-mail: [kozomorasandra@gmail.com](mailto:kozomorasandra@gmail.com)

**Abstract :** This work represents a review of safety and health risks for workers at the animal waste incineration plant. This paper describes the subject plant for incineration of animal corpses with small capacity and of the work process of the operator for the procedure of animal waste incineration. The method for risk assessment in the workplace and work environment is presented in detail. The analysis of the obtained results based on the assigned assessments for the probability and severity of injuries or illnesses at work, the total level of risk for each hazard or harmfulness is determined separately and shown in this paper.

**Key words:** Safety and health on work, animal waste, incineration

### INTRODUCTION

When working in a plant for the treatment of any type of waste, it is necessary to provide employees with healthy and a safe environment, as well as the use of personal protective equipment [2, 4]. When providing working conditions and environment, it is necessary to implement prevention measures and minimize accidents and exposure to risks. An important aspect of risk prevention is also maximizing the professionalism and expertise of employees.

In order to establish an adequate system of safety and health of employees in waste management in terms of waste treatment by incineration, it is necessary to implement the following steps:

- Comprehensive and daily supervision of employees;
- Establishment of guidelines and operational procedures whose applicability and effectiveness are periodically assessed;
- Establishing a hygienic-sanitary procedure at work [11];
- Periodic assessment of employee health and safety program based on best available techniques and regulatory regulations;
- Defining employee safety and health training and practical training programs that are conducted periodically at least once a year [5].

An important aspect of safety and health at work is the behaviour and habits of workers in the workplace. Worker behaviour is determined by many factors such as:

- Environmental factors: social support, ability to change one's environment;
- Behavioral factors: skills, work efficiency and the like;
- Cognitive factors: knowledge, perception, expectations and attitudes.

Workers who handle waste are exposed to microbes, which is one of the problems of safety and health at work [1]. Waste management has been associated with diarrhea, organic dust, skin irritation, and symptoms of airway inflammation [10, 14, 8, 9, 13]. Oxidative stress and inflammatory processes measured in blood samples of waste management workers affect the working life [6]. Multiple studies show an association between acute nasal irritation and exposure to bacteria at work with a tendency to associate between coughing and exposure to fungal spores [3]. Based on the Poole and Basu review, it was concluded that there is insufficient evidence to establish exposure limits for workers in the waste sector [9]. Understanding the health and safety behaviours of people working in the waste treatment sector should be presented to employees, i.e. they should be shown how to perceive the risk associated with waste and what are the factors that affect their work from the safety aspect [12]. The aim of this

paper is to indicate the risks that employees at the workplace of animal waste treatment encounter during their work. A risk assessment at the workplace and in the work environment will be performed for the position of operator for the procedure of incineration of animal waste in a small capacity incineration plant.

## MATERIAL AND METHODS

### Description of the work process of the Operator for the procedure of animal waste incineration

The animal waste incineration operator operates a small incineration plant of 150 - 400 kg of animal waste per hour of model INCINER8 Model I8-250 (incinerator) shown in Figure 1, depending on the type of animal material for incineration. Within the subject plant, reception (transport refrigerators), temporary storage (in a container-type refrigerator) and incineration treatment are performed. The plant in question is an actual plant for the incineration of animal material.



**Fig. 1.** Incinerator INCINER8 Model I8-250, on the right side there is a sanitary and office container, and on the left side there is a refrigerator of the container type.

The work process of the Animal Waste Incineration Operator is:

- Performs tasks in accordance with the work plan of the plant;
- In case of an accident, implement an accident protection plan;
- Manages the equipment in accordance with the relevant technical instructions;
- Manages the operation of moving animal waste from the means of transport to the refrigerator;
- Provides waste of animal origin and protects it from spoilage and leakage;
- Keeps records of received and incinerated waste of animal origin;
- Monitors the operation of the incinerator – temperature specifications;
- Take care of safety when transferring fuel to the incinerator tank.

The work of the operator for the procedure of incineration of animal waste is performed mostly in the incinerator during the maintenance of the furnace and control of its operation. Workspace lighting is a combination of natural and artificial. Ventilation is natural.

The equipment for work used at the workplace of the operator for the process of incineration of animal waste in a small capacity incinerator are incinerator for incineration of animal waste, electric crane - winch, set of hand tools, kiln maintenance accessories (wire brush, brush, sponge, spatula, broom). Raw materials used at the operator's workplace for the process of incineration of animal waste in a small capacity incinerator are animal waste, products of incinerated animal waste - ash, fuel - diesel or biodiesel.

Means and equipment for personal protection at work and work clothes used at the workplace of the operator for the process of incineration of animal waste in a small capacity incinerator are work suit, work shoes, rubber boots, jacket, leather and cloth gloves, thermal protective gloves, disposable mask, filter mask with protection against organic vapours.

### **Method for risk assessment in the workplace and work environment**

The probability of injury at work, damage to health or illness of employees related to work, caused by hazards and harms in the workplace and in the work environment or at work, is estimated based on the analysis of collected data on organization and working conditions, as well as professional findings (i.e. the existing state of safety at the workplace), which takes into account the frequency or duration of exposure to hazards and hazards, as well as the state of protection, i.e. the level of danger to the employee in the workplace and work environment.

The probability of occurrence of an injury at work (P), damage to health or illness of employees at the workplace of the operator for the procedure of incineration of animal waste is determined using the probability matrix given in Table 1.

**Table 1.** Probability of occurrence of an injury [7, modified]

<b>Frequency</b>		<b>Very rarely</b>	<b>Rarely - occasionally</b>	<b>Frequently</b>	<b>Often</b>
		<b>Very short 0-10%</b>	<b>Short 10-33%</b>	<b>Longer 33-66%</b>	<b>Constantly – mostly 66-100%</b>
<b>Duration in time</b>		<b>1</b>	<b>2</b>	<b>3</b>	<b>4</b>
<b>Condition of protection (Danger)</b>		<b>1</b>	<b>2</b>	<b>3</b>	<b>4</b>
Satisfactory (Very small)	<b>1</b>	1	1	2	3
Necessary measures, but not urgent (Small)	<b>2</b>	1	2	3	4
Required measures (Medium)	<b>3</b>	2	3	4	5
Urgent measures required (Large)	<b>4</b>	3	4	5	5

Based on the previous analysis of parameters in the workplace and in the work environment and the probability matrix, given in Table 1, an estimate of the probability of injury and illness was obtained (Table 2). The assessment of the severity of a possible occupational injury (D), damage to health or illness of employees is assessed on the basis of injuries at work, damage to health or illness of employees that previously occurred in the workplace or on the basis of presumed expected injury at work as shown in Table 3.

**Table 2.** Mark of the probability of injury and disease (P) [7, modified]

<b>Mark 1</b>	– <b>Very small</b>
<b>Mark 2</b>	– <b>Small</b>
<b>Mark 3</b>	– <b>Possible occurrence</b>
<b>Mark 4</b>	– <b>Large</b>
<b>Mark 5</b>	– <b>Very large</b>

**Table 3.** Mark of the severity of a possible injury at work (D) [7, modified]

<b>Mark 1</b>	An occurrence that can cause minor injuries, damage or loss (scratches, bruises, cuts, lacerations, etc.)
<b>Mark 2</b>	An occurrence that affects human health and safety at work and that can lead to damage or loss (fracture of small bones, minor temporary illnesses)
<b>Mark 3</b>	An occurrence that leads to impairment of health and injuries, which do not jeopardize a person's life, or damage and other losses that can be mainly compensated (fracture of the main bones, severe temporary illnesses)
<b>Mark 4</b>	An occurrence that leads to serious damage to health, injury, damage or other losses that can be partially compensated (loss of an eye, hearing, extremities, permanent diseases)
<b>Mark 5</b>	An occurrence leading to death, significant impairment of health, injury, damage or other critical losses that cannot be compensated (loss of vision, multiple extremities, severe permanent illness, fatal outcome)

The risk is the probability of injury, illness or damage to the health of the employee due to danger or harmfulness. Risk levels are defined by a matrix, given in Table 4, by different combinations of pre-determined probability estimates (P) and consequences (D), in accordance with the OHSAS 18001 standard. The following Table 4 provides a risk assessment in the form of a “5 x 5” matrix.

**Table 4.** Risk matrix [7, modified]

		Severity of injury (D)				
		1	2	3	4	5
Probability of injury (P)	1	A	B	B	C	C
	2	B	B	C	C	D
	3	B	C	C	D	D
	4	C	C	D	D	E
	5	C	D	D	E	E

The risk assessment at the analysed workplace was performed on a five-point scale. Thus, the analysed jobs are divided into five categories that determine activities depending on the level of risk, which can be seen in Table 5.

When it is determined that in the workplace, in addition to fully or partially applied measures in the field of safety and health at work, there are dangers and harms, which according to the risk assessor can cause injury or endanger the health of the employee, such a place is at increased risk (Marks of risk level D and E).

**Table 5.** Risk level [7, modified]

Mark	Risk level	Action
A	Inconsiderable	No action is required.
B	Permissible	No additional risk management activities are required. It is necessary to monitor the situation in order to have information on the implementation of the applied preventive measures.
C	Moderate	Corrective measures need to be taken to reduce the risk. It is necessary to define a deadline for the implementation of corrective measures.
D	Significant	Urgent measures need to be taken to reduce risk levels.
E	Inadmissible	The activity must not be started or continued until the level of risk is reduced.

## RESULTS AND DISCUSSION

Based on the observed work process of the incineration of animal corpses and remains operator, the possible dangers and harms that the employee may encounter during his work are defined. After defining the danger and harmfulness, the source of danger for a specific danger or harmfulness is identified. In order to more efficiently assess the risk at the workplace, the applied preventive measures provided by the employer are defined, which affect the assessment of the level of risk for a specific danger or harmfulness.

After considering the danger or harmfulness at the workplace, parameters that are important for assessing the level of risk faced by the employee, such as the probability of injury or illness and the severity of possible injury at work, are assessed.

Based on the assigned assessments for the probability and severity of injuries or illnesses at work, the total level of risk for each hazard or harmfulness is determined separately and the level of risk is determined, which can be seen in Table 6.

**Table 6.** Hazard and Harm Assessment at the Workplace and Work Environment for the Animal Waste Incineration Operator

Dangers and harmfulness	Source of danger, harmfulness and effort	Preventive measures applied	P	D	R	Risk level
Insufficient safety due to rotating parts	Rotating and moving parts of transmission mechanisms and individual working mechanisms on devices that the employee handles.	The employees were trained for safe and healthy work. Inspection and testing of the correctness of furnaces and cranes was performed. There are mechanical protections on the moving parts of the power transmission and the working mechanisms of the device.	2	2	B	Permissible
Internal transport and movement of working machines or vehicles	Danger from moving vehicles carrying animal waste.	Waste collection is done at the unloading ramp. Adherence to reception and temporary storage procedures. The employees were trained for safe and healthy work.	1	3	B	Permissible
Use of hazardous work equipment that can produce explosions or fire	Possibility of fuel ignition during refill.	Fuel should only be handled in well-ventilated areas away from heat, sparks, or flames. Smoking is prohibited when working with fuel.	2	2	B	Permissible
Mechanical Shocks	Mechanical shock to the extremities, the lid of the furnace, the fall of the load from the cranes, transport container, truck etc.	Inspection and testing of the correctness of furnaces and cranes was performed. The oven lid is lifted by a winch. Use of appropriate personal protective equipment.	2	2	B	Permissible

Hand tools (which can cause injuries when used)	Working with hand tools.	Use of appropriate personal protective equipment.	2	2	B	<b>Permissible</b>
Danger of indirect contact (all non-grounded electrical equipment)	Work with electrical devices.	There is an automatic power off system. Inspection and testing of electrical installations was performed. The employees were trained.	2	3	C	<b>Moderate</b>
Dangers due to lightning strikes and atmospheric discharge	Danger of lightning and atmospheric discharge.	The facility has lightning protection installations that have been inspected and tested.	1	4	C	<b>Moderate</b>
Warm and hot surfaces	Danger from hot surfaces (hot parts of the incinerator).	Use of appropriate personal protective equipment (thermal protective gloves, thermal protective suit).	4	2	C	<b>Moderate</b>
Possibility of sliding (wet or slippery surfaces)	Danger of wet and slippery surfaces in winter outdoors, possibility of slipping.	Regular maintenance of trails, sprinkling with salt, cleaning in the winter.	2	2	B	<b>Permissible</b>
Exposure to vapours and dusts	Steam and dust generated during the incineration of animal waste. The ash that is the remnant of the incineration.	Use of appropriate personal protective equipment (disposable mask, mask for filter protection against organic vapours). The generated ash is non-hazardous, and is treated as municipal waste.	3	2	C	<b>Moderate</b>
Biological hazards	Diseases that animals can transmit to humans. Working with animal waste.	Use of appropriate personal protective equipment (protective gloves, protective work clothes, etc.). Use of hand sanitizers. Sanitary and hygienic procedures are provided.	4	3	D	<b><u>Significant</u></b>
Adverse effects of microclimate	Harmful influence of the microclimate in the work space	The examination of the working environment conditions (microclimate) for the winter period in the work space was performed.	2	1	B	<b>Permissible</b>
Inadequate - insufficient lighting	Insufficient lighting of the working space.	A test of the brightness in the workspace was performed.	2	1	B	<b>Permissible</b>
Harmful effects of radiation	Thermal radiation - the heat emitted by an incinerator	Use of thermal protective suit, thermal face protection, and especially when opening the oven, thermal protective gloves.	4	3	D	<b><u>Significant</u></b>
Harmful climatic influences	Working outdoors in everyday work.	Use of appropriate personal protective equipment.	2	2	B	<b>Permissible</b>

Physical exertion (pushing or pulling a load)	Physical exertion during the work on the loading ramp and refrigerator loading.	Transshipment is done by means of transport containers which are transported to the refrigerator by hand forklifts.	2	2	B	Permissible
Non-physiological body position (prolonged standing)	Long standing (longer working hours).	Take breaks from work and occasionally sit down	3	2	C	Moderate
Use of appropriate knowledge and skills	Use of appropriate knowledge and skills	-	2	1	B	Permissible

Based on the obtained results by risk assessment using the matrix method for the position of Animal Waste Incineration Operator, we can conclude that the observed workplace is a workplace with increased risk based on dangers and harmfulness in which we obtained a significant level of risk such as heat radiation and biological hazards. After the obtained results of risk assessment at the workplace and work environment, it is necessary to define corrective measures of protection at work that can contribute to the reduction of risk levels as well as deadlines for the application of such measures.

## CONCLUSION

In accordance with the obtained results for risk levels for the workplace Operator for the procedure of incineration of animal waste, i.e. given that the observed workplace with increased risk, it is necessary to further implement all applications presented in the results and discussion of risk assessment in the workplace and work environment and corrective measures that are subsequently defined in order to minimize the hazards and harms that have been assessed. The main measures for risk reduction are the use of assessed personal protective equipment and training of employees for safe and healthy work, as well as training for practical training with a knowledge test once a year. It is necessary to monitor the health status of employees with periodic health checks once a year. The most important purpose of occupational health and safety is its preventive action in order to prevent injuries at work and occupational diseases.

## ACKNOWLEDGMENT

This paper has been supported by the Ministry of Education, Science and Technological Development through the projects no. 451-03-68/2020-14/200156 and by the Government of Perm Krai, research project No C-26/174.6.

## REFERENCES

- [1] Binion, E., Gutberlet, J., The effects of handling solid waste on the wellbeing of informal and organized recyclers: a review of the literature, *International Journal of Occupational and Environmental Health*, Vol.18, No.1, pp. 43–52, 2012.
- [2] Hall, S.K., Health Surveillance of Hazardous Materials Workers, *Pollution Engineering*, Vol.24, No.9, pp. 58-62, 1992.
- [3] Heldal, K.K., Eduard, W., Associations between acute symptoms and bioaerosol exposure during the collection of household waste, *American Journal of Industrial Medicine*, Vol.46, No.3, pp. 253–260, 2004.
- [4] Lange, J.H., Spence, P.L. and Rosato, P.A., A Medical Surveillance Program for Hazardous Waste Activities and Asbestos Abatement Operation for a Consulting Engineering Firm, *Journal of Environmental Science and Health Part A*, Vol.26, No.6, pp. 953-970, 1991.

- [5] Levine, S. P., Turpin, R.D. and Gochfeld, M., Protecting Personnel at Hazardous Waste Sites: Current Issues, *Applied Occupational and Environmental Hygiene*, Vol.6, No.12, pp. 1007-1014, 1991.
- [6] Odewabi, A.O., Ogundahunsi, O.A., Ekor, M. Effect of exposure to solid wastes in relation to employment duration on some important markers of health and disease in waste management workers of Ogun State in southwest Nigeria, *Hum. Exp. Toxicol.*, Vol.32, No.12, pp. 1231–1244, 2013.
- [7] OHSAS 18001:2008 standard, Occupational Health & Safety Assessment Series International Standard, 2008.
- [8] Perez, H.R., Frank, A.L., Zimmerman, N.J., Health effects associated with organic dust exposure during the handling of municipal solid waste, *Indoor and Built Environment*, Vol.15, No.3, pp. 207–212, 2006.
- [9] Poole, C.J.M., Basu, S., Systematic review: occupational illness in the waste and recycling sector, *Occupational Medicine*, Vol.67, No.8, pp. 626–636, 2017.
- [10] Poulsen, O.M., Breum, N.O., Ebbenhøj, N., et al., Sorting and recycling of domestic waste. Review of occupational health problems and their possible causes, *Science of the Total Environment*, Vol.168, No.1, pp. 33–56, 1995.
- [11] Robinson, S. T., Role of Industrial Hygiene in Medical Surveillance, *Occupational Medicine*, Vol.5, No.3, pp. 469-478, 1990.
- [12] Sapkota, S., Lee, A., Karki, J., Makai, P., Adhikari, S., Chaudhuri, N., Fossier-Heckmann, A., Risks and risk mitigation in waste-work: A qualitative study of informal waste workers in Nepal, *Public Health in Practice*, Vol.1, pp. 2666-5352, 2020.
- [13] Thakur, P., Ganguly, R., Dhulia, A., Occupational health hazard exposure among municipal solid waste workers in Himachal Pradesh, India, *Waste Manage.*, Vol.78, pp. 483–489, 2018.
- [14] Yang, C.Y., Chang, W.T., Chuang, H.Y., et al., Adverse health effects among household waste collectors in Taiwan, *Environmental Research*, Vol.85, No.3, pp. 195–199, 2001.



## IDENTIFICATION AND SIGNIFICANCE OF GRAM-NEGATIVE BACTERIA IN MUNICIPAL SOLID WASTE LANDFILL LEACHATE FROM VOJVODINA REGION

Katarina Antić<sup>1</sup>, Zoran Čepić<sup>1</sup>, Milena Stošić<sup>1</sup>, Jelena Radonić<sup>1</sup>

<sup>1</sup>University of Novi Sad, Faculty of Technical Sciences, Department of Environmental Engineering and Occupational Safety and Health, Novi Sad, Serbia

e-mail: [zorancepic@uns.ac.rs](mailto:zorancepic@uns.ac.rs)

**Abstract:** Landfill leachate is a medium affected by a considerable number of factors, both within the landfill body (landfill age, morphological composition of waste, temperature and moisture content, landfill fluid migration, waste treatment technologies before disposal, landfill body thickness, waste decomposition phases), and outside (meteorological parameters, with an emphasis on annual precipitation). Variable and almost unpredictable qualitative composition of leachate from municipal solid waste landfills, that often includes emerging substances, such as antibiotics and endocrine disruptors, as well as heavy metals, significantly affects the structure and diversity of the present microbiological communities. By implementing leachate sampling campaigns in the winter, spring and autumn in 2019 at three non-sanitary ( $L_1$ ,  $L_2$ ,  $L_3$ ) and one sanitary ( $L_4$ ) municipal solid waste landfills in the region of Vojvodina, the presence of microorganisms *Escherichia coli*, *Klebsiella pneumoniae* and *Citrobacter freundii*, Gram-negative bacteria from the family of *Enterobacteriaceae*, in the phylum *Proteobacteria*, were detected. Due to the frequent causing of urinary, extraintestinal, diarrheal and respiratory infections, meningitis, colitis, sepsis, as well as high resistance to a range of antibiotics, Gram-negative bacteria may represent a potential risk to human and animal health, under specific exposure circumstances. In addition to the use of Gram-negative bacteria *Escherichia coli*, *Klebsiella pneumoniae* and *Citrobacter freundii* as indicators of fecal contamination, the potential of the use of the mentioned bacteria as indicators of contamination of leachate with heavy metals and organic compounds, as well as the functionality and condition of municipal solid waste landfills.

**Key words:** municipal solid waste landfills, municipal solid waste landfill leachate, microbiological parameters, Gram-negative bacteria

### INTRODUCTION

#### Municipal Solid Waste Landfill Leachate

Landfill leachate is a medium affected by a considerable number of factors, both within the landfill body (landfill age, morphological composition of waste, temperature and moisture content, landfill fluid migration, waste treatment technologies before disposal, landfill body thickness, waste decomposition phases), and outside (meteorological parameters, with an emphasis on annual precipitation). The process of landfill filtrate formation includes dissolution and dispersion of solid substances in water that is percolated through the landfill body and dissolved or suspended substances formed through biological and chemical processes taking place inside the landfill body [1].

The process of generating leachate is an integral part of the water movement cycle at a landfill. The beginning of the cycle is characterized by percolating of the received atmospheric precipitation through active layers of the deposited waste. In the process, organic and inorganic substituents, heavy metals and potentially hazardous substances present in the active layers of deposited waste are dissolved, and the process of combining percolated precipitation with moisture percolated from active layers of deposited waste is realized, thus forming an optimal medium for pollutant transport. A certain part of the formed filtrate flows away from the landfill, part returns to the atmosphere through evaporation from the upper surface of the landfill body or vegetation (transpiration), while the remaining amount of formed filtrate remains in the upper layer of the landfill, whereby moisture in waste increases and conditions for the continuous production of new volumes of leachate are ensured.

It is very difficult to predict the composition of the landfill leachate due to the complex dynamics of the processes taking place in the landfill body and the impact of a large number of factors. Qualitative, as well as quantitative composition of leachate can vary over time, and the load of pollutants reaches its peak several years after waste disposal, with a subsequent decline [2,3]. The qualitative

composition of leachate is characterized by pollutants that fall into four basic groups [4,5]: *soluble organic components* (volatile fatty acids, varieties of humic and fulvic acids), *inorganic macrocomponents* (ions of calcium (Ca<sup>2+</sup>), magnesium (Mg<sup>2+</sup>), sodium (Na<sup>+</sup>), potassium (K<sup>+</sup>), ammonium (NH<sub>4</sub><sup>+</sup>), iron (Fe<sup>2+</sup>), manganese (Mn<sup>2+</sup>), chloride (Cl<sup>-</sup>), sulphate (SO<sub>4</sub><sup>2-</sup>)), *heavy metals* (ions of cadmium (Cd<sup>2+</sup>), chromium (Cr<sup>3+</sup>), copper (Cu<sup>2+</sup>), lead (Pb<sup>2+</sup>), nickel (Ni<sup>2+</sup>) and zinc (Zn<sup>2+</sup>)), *xenobiotic organic components* (hydrocarbons, phenols, chlorinated aliphatic compounds, pesticides, dioctyl phthalate).

### **Microbial Structures present in Landfill Leachates**

The general division of living organisms is made into three domains - *bacteria*, *archaea* and *eukaryotes* [6,7]. The basic mechanisms and processes that take place within the municipal solid waste landfill are characterized by the presence and activity of representatives of all three previously mentioned categories.

Variations in the composition of microbiological communities due to the action of a substantial number of factors within the landfill body, such as landfill age, morphological composition of waste, temperature and moisture content, landfill fluid migration, waste treatment technologies before disposal, landfill body thickness, waste decomposition phases, are known from the literature and presented in Table 1.

Municipal solid waste landfills more than 10 years old are characterized by lower acetate concentration, lower microbiological activity, as well as a smaller number of cellulolytic bacteria [8,9]. Conditions at the mentioned landfills, namely low content of hydrocarbon (6.4 ± 1.6% of dry mass) and high pH values (7.9 ± 0.35) are in favor of the survival of gram-positive bacteria from the *Bacillaceae* family, especially the genus *Bacillus*. However, the mentioned conditions are not in favor of the survival of bacteria from *Proteobacteria* and *Methanosaeta* families. Different depths of sampling disposed waste indicate significant variations in the microbiological communities present. The deeper layers of the disposed waste are characterized by lower concentrations of acetate, due to which they represent the optimal environment for the development of *Methanoculleus*. Contrary to the above, higher layers of disposed waste are characterized by substantial concentrations of acetate that are in favor of the survival of *Methanosarcin*, resulting in a greater activity related to methane production [10]. High intake of organic matter, as well as the accumulation of acetate characterizes landfills with implemented leachate recirculation treatment. These conditions are in favor of *Methanosarcin*, but not of bacteria from *Proteobacteria* and *Methanosaeta* families [10]. Low temperatures in general lead to the formation of more diverse microbiological communities [10]. *Proteobacteria* dominate landfill sites contaminated primarily with hydrocarbons, polycyclic aromatic hydrocarbons, polychlorinated biphenyls, and heavy metals [11].

**Table 1.** Complex connections of microbial structures with specific landfill features [12]

Feature		Note	Characteristic
<b>SAMPLE AGE</b>	Old refuse samples	Lower concentration of acetate; Lower microbial activity; Lower number of cellulolytic bacteria.	Domination of the family <i>Bacillaceae</i> .
			Domination of the genus <i>Bacillus</i> .
			Identification of extremophiles (alkaliphiles and halophiles).
			High abundance of <i>Bacillus</i> -like DNA sequences.
			<i>Proteobacteria</i> are favoured.
			Favorable conditions for <i>Methanosaeta</i> .
			Favorable conditions for hydrogenotrophic and formate-using methanogens.

	Young refuse samples	Higher concentration of acetate; Higher microbial activity; Higher number of cellulolytic bacteria.	Unfavorable conditions for gram- bacteria like <i>Proteobacteria</i> . Favorable conditions for <i>Methanosarcina</i> . Favorable conditions for acetolactic, hydrogenotrophic and formate-using methanogens.
	--	--	Significant structure changes of the methanogenic community happen shortly after waste burial.
<b>DEPTH</b>	Deeper waste layers	Lower concentration of acetate.	Favorable conditions for <i>Methanoculleus</i> .
	Upper waste layers	Higher concentration of acetate.	Favorable conditions for <i>Methanosarcina</i> . Higher methane production activity.
<b>HIGH pH</b>	Incineration ash layer in landfill	--	Dominated by <i>Bacillus</i> .
<b>ORGANIC MATTER CONCENTRATIONS</b>	High organic matter concentrations	--	High diversity of microbial communities.
<b>LEACHATE</b>	Full-scale recirculation of leachate	High input of organic matter associated with leachate recirculation; Accumulation of acetate.	Favorable conditions for <i>Methanosarcina</i> ; No detection of <i>Methanosaeta</i> . Very low abundance of <i>Proteobacteria</i> .
	Closed landfill	Stable conditions.	Favorable conditions for <i>Methanosaeta</i> ; Low abundance of <i>Methanosarcina</i> . High abundance of <i>Proteobacteria</i> , mainly <i>Gammaproteobacteria</i> .
<b>TEMPERATURE</b>	Lower Temperature	--	Higher microbial diversity.
	High Temperature	40-50 °C	Low archaeal diversity.
<b>CONTAMINATED SITE</b>	Pollutants: Hydrocarbons; PAH; PCB; Heavy metals.	--	Domination of <i>Proteobacteria</i> .
	Contamination intensity		Lowest microbial diversity and lowest enzymatic activity in areas with highest pollutant concentrations

Optimal conditions for the development and survival of Gram-negative bacteria from the family *Enterobacteriaceae*, phylum *Proteobacteria*, are the pH value of the environment between 6.6 and 7.5, as well as the temperature of 35 °C [13]. An overview of the identification of Gram-negative bacteria in municipal solid waste landfill leachate done by some other authors are shown in Table 2.

**Table 2.** Identification of Gram-negative bacteria in the MSW landfill leachate

SPECIES	LANDFILL SITE	REFERENCE
<i>Proteus mirabilis</i> ; <i>Klebsiella pneumoniae</i> ; <i>Escherichia coli</i> ; <i>Acinetobacter calcoaceticus</i> ; <i>Yersinia enterocolitica</i> ; <i>Stenotrophomonas maltophilia</i> ; <i>Citrobacter freundii</i> .	Noble Hill Sanitary Landfill at Springfield, USA	[14]
<i>Actinobacillus pleuropneumoniae</i> ; <i>Bordetella</i> sp.; <i>Escherichia coli</i> var II; <i>Brucella</i> sp.; <i>Acinetobacter baumannii</i> ; <i>Klebsiella pneumoniae</i> ; <i>Ochrobactrum anthropi</i> ; <i>Salmonella</i> spp.	San Nicolás landfill at Aguascalientes, Mexico	[15]
<i>Klebsiella pneumoniae</i> ; <i>Escherichia coli</i> ; <i>Citrobacter freundii</i> ; <i>Proteus mirabilis</i> ; <i>Vibro</i> spp.; <i>Salmonella</i> spp.	Five active landfill sites in the Ashanti Region, Ghana	[16]

## MATERIAL AND METHODS

Leachate sampling campaigns were carried out in the winter, spring and autumn of 2019, in cycles of 2 hours at each location. Sampling was carried out in accordance with instruction Q3.BP. 853 (in accordance with SRPS EN ISO 19458:2009) at three non-sanitary ( $L_1$ ,  $L_2$ ,  $L_3$ ) and one sanitary ( $L_4$ ) municipal solid waste landfill in the region of Vojvodina. At each site, 0.5 L of leachate was collected for the purpose of microbiological analyses. All samples were delivered to the laboratory and stored at a temperature of 4 °C until the sample was prepared for analysis.

Microbiological analyses were carried out at the Institute of Public Health of Vojvodina in Novi Sad, Republic of Serbia.



**Fig. 1.** Three non-sanitary,  $L_1$  (upper left),  $L_2$  (upper right),  $L_3$  (lower left) and one sanitary,  $L_4$  (lower right) MSW landfills from the region of Vojvodina on which landfill leachate sampling was conducted

## RESULTS AND DISCUSSION

The results of microbiological analyses of leachate sampled at three non-sanitary ( $L_1$ ,  $L_2$ ,  $L_3$ ) and one sanitary ( $L_4$ ) municipal solid waste landfill in the region of Vojvodina in the winter, spring and summer period are shown in Table 3.

**Table 3.** Species of identified microorganisms at four MSW landfill sites by seasons

	$L_1$	$L_2$	$L_3$	$L_4$
<b>Winter</b>	<i>Escherichia coli</i> (37°C, 44°C); <i>Klebsiella pneumoniae</i> (37°C, 44°C).	/	<i>Escherichia coli</i> (37°C, 44°C); <i>Klebsiella pneumoniae</i> (37°C, 44°C).	<i>Escherichia coli</i> (37°C, 44°C).
<b>Spring</b>	<i>Klebsiella pneumoniae</i> (37°C, 44°C).	<i>Citrobacter</i> spp. (37°C, 44°C); <i>Escherichia coli</i> (37°C, 44°C).	<i>Escherichia coli</i> (37°C, 44°C); <i>Klebsiella pneumoniae</i> (37°C, 44°C).	<i>Citrobacter freundii</i> (37°C, 44°C); <i>Klebsiella pneumoniae</i> (37°C, 44°C).
<b>Autumn</b>	<i>Escherichia coli</i> (37°C, 44°C); <i>Klebsiella oxytoca</i> (37°C, 44°C).	<i>Escherichia coli</i> (37°C, 44°C).	<i>Escherichia coli</i> (37°C, 44°C); <i>Klebsiella oxytoca</i> (37°C, 44°C).	<i>Citrobacter freundii</i> (37°C, 44°C); <i>Escherichia coli</i> (37°C, 44°C).

Frequently identified microorganisms at all four municipal solid waste landfill sites are *Escherichia coli* and *Klebsiella pneumoniae*. The presence of *Citrobacter freundii* microorganisms was identified

at the  $L_2$  landfill site in the spring season, as well as at the  $L_4$  landfill site during the spring and autumn seasons.

The detected microorganisms *Escherichia coli*, *Klebsiella pneumoniae* and *Citrobacter freundii* are Gram-negative bacteria from the family of *Enterobacteriaceae*, phylum *Proteobacteria* [17].

*Escherichia coli* is an aerobic and facultatively anaerobic bacteria that ferments lactose. It grows well in laboratory conditions, and for most serotypes the optimal temperature for reproduction is around 37°C. It is a rather resistant bacteria and it can survive in water and soil for months, with an extended period of staying on various objects. It reproduces easily and quickly in different types of food. A temperature of 60°C can kill them after 15 min [17]. *Escherichia coli* falls into the group of coliform bacteria, as it belongs to the normal human gut flora. In respect of the above, in sanitary inspections of drinking water and food they are used as indicators of fecal contamination. The mentioned bacteria can cause extraintestinal and diarrheal diseases in humans. This bacteria can be transmitted through intake of contaminated water and food and through contact with infected humans and animals [17].

*Klebsiella pneumoniae* is a facultative anaerobic bacterium that ferments lactose. The mentioned bacteria are characterized by rounded ends, they have no flagella and they are immobile, and so they are distributed individually or in pairs. Fimbriae with adherent properties and a capsule are significant virulence factors [17]. *Klebsiella pneumoniae* is a common cause of a hospital-acquired pneumonia and infections in immunocompromised patients. The nasopharynx and intestines are the centers of concentration and routes of transmission of the mentioned bacterium in humans. However, fecal contamination is the most common cause of infections caused by *Klebsiella pneumoniae* [17].

*Citrobacter freundii* is a facultatively anaerobic bacterium that does not ferment lactose. In general, most of the mentioned bacteria are characterized by the presence of several flagella for the purpose of movement, but there are also exceptions to the mentioned case. The above bacteria can be found in soil, water, sewage, food, but also in the digestive tract of animals and humans [17]. *Citrobacter freundii* is mentioned as the cause of infections of the urinary tract and respiratory organs, meningitis, sepsis, while their presence is also detected in decubitus ulcers. They are also a cause of healthcare associated infections, especially in pediatric and immunocompromised patients [17].

Based on the above, as causes of urinary, extraintestinal, diarrheal and respiratory infections, meningitis, colitis, and sepsis, *Escherichia coli*, *Klebsiella pneumoniae* and *Citrobacter freundii* may pose a significant risk to human and animal health, under certain exposure circumstances.

The presence of the mentioned Gram-negative bacteria from the phylum *Proteobacteria* can also be used as an indicator of the performance of landfill sites at which sampling was done, as well as the qualitative composition of leachate. The lower diversity of microbiological communities at landfills  $L_1$ ,  $L_2$ ,  $L_3$  and  $L_4$  indicates the prevailing conditions, which is - lower concentrations of acetate and hydrocarbons, as well as high pH value that characterize landfill sites that are more than 10 years old. Recirculation of municipal solid waste landfill leachate, as a primary treatment, is characterized by a high content of organic matter and accumulation of acetate, which are not favorable conditions for the development and survival of a range of Gram-negative bacteria. Based on the research conducted by other authors, it has been determined that due to the high concentrations of total hydrocarbons, significant microbiological enzyme activity was detected [11]. According to the above conclusions, identification of Gram-negative bacteria from the phylum *Proteobacteria* may also indicate contamination of leachate with organic pollutants, primarily hydrocarbons, polycyclic aromatic hydrocarbons, polychlorinated biphenyls and heavy metals [11].

Municipal solid waste landfills are very complex environments with variable and almost unpredictable qualitative composition of leachate, which often includes emergent substances, such as antibiotics and endocrine disruptors, as well as heavy metals, which significantly affect the structure and diversity of present microbiological communities. Therefore, the risk of developing antibiotic resistance in microorganisms is constantly increasing. The literature data according to which we are led to this doubt refers that the 50 *Escherichia coli* isolates tested were resistant to the antibiotics penicillin and erythromycin (100%), nalidixic acid (98%), cephalexin (94%), amoxicillin (86%), ampicillin (84%), ciprofloxacin (74%), tetracycline (64%), cefixime (54%) and gentamicin (36%) [18]. Most *Klebsiella pneumoniae* isolates showed an outstanding antibiotic resistance. A more favorable situation was only in the case of meropenem (1.20%), amikacin (4.79%) and piperacillin/tazobactam (10.53%) [19]. Gram-negative bacteria *Citrobacter freundii* showed antibiotic resistance to aminoglycoside

antibiotics (gentamicin, netilmicin and amikacin), fluoroquinolone antibiotics (levofloxacin, ciprofloxacin) and carbapenems (ertapenem, imipenem) and meropenem [20].

Due to the high prevalence of antibiotic resistance in Gram-negative bacteria from the family of *Enterobacteriaceae*, phylum *Proteobacteria*, displayed in numerous studies, there is an obvious need for careful monitoring of landfill leachate microbiological and physico-chemical properties. In addition, there is a necessity for the properly done exposure assessment of humans and animals to this leachate, in order to minimize and avoid possible health risk.

## CONCLUSION

The presence of microorganisms *Escherichia coli*, *Klebsiella pneumoniae* and *Citrobacter freundii*, Gram-negative bacteria from the family of *Enterobacteriaceae*, phylum *Proteobacteria* was detected after analyzing microbiological parameters of leachate sampled from three non-sanitary ( $L_1$ ,  $L_2$ ,  $L_3$ ) and one sanitary ( $L_4$ ) municipal solid waste landfill in the region of Vojvodina in the winter, spring and autumn periods. Frequently detected Gram-negative bacteria at all four municipal solid waste landfills are *Escherichia coli* and *Klebsiella pneumoniae*. The presence of *Citrobacter freundii* bacteria was detected at the  $L_2$  landfill site during the spring season and at the  $L_4$  landfill site during the spring and autumn seasons.

The presence of the mentioned Gram-negative bacteria of the *Proteobacteria* phylum can also be used as an indicator of the performance of landfill sites at which sampling was done, such as landfill age, morphological composition of waste, landfill body thickness, waste decomposition phases, as well as the qualitative composition of leachate. The lower diversity of microbiological communities at landfills  $L_1$ ,  $L_2$ ,  $L_3$  and  $L_4$  indicates the prevailing conditions, i.e. lower concentrations of acetate and hydrocarbons, as well as high pH values, characteristic for landfill sites that are more than 10 years old. Recirculation of municipal solid waste landfill leachate, as a primary treatment, is characterized by a high content of organic matter and accumulation of acetate, which are not favorable conditions for the development and survival of a range of Gram-negative bacteria. Identification of Gram-negative bacteria of the *Proteobacteria* phylum also indicates contamination of leachate with organic pollutants, primarily hydrocarbons, polycyclic aromatic hydrocarbons, polychlorinated biphenyls and heavy metals.

Gram-negative bacteria *Escherichia coli*, *Klebsiella pneumoniae* and *Citrobacter freundii* have been identified as common causes of urinary, extraintestinal, diarrheal and respiratory infections, meningitis, hemorrhagic and entero-hemorrhagic colitis, sepsis. Due to the data presented in the literature related to the antibiotics resistance of Gram-negative bacteria, it is necessary to pay attention to this phenomenon in the case of the analyzed leachates from the Vojvodina region.

By optimizing and enhancing the analyses of microbiological parameters of leachate, besides the use in the form of fecal contamination indicators, Gram-negative bacteria could also become potentially reliable indicators of leachate contamination with heavy metals and organic compounds, as well as indicators of functionality and condition of municipal solid waste landfills.

## ACKNOWLEDGMENT

This paper has been supported by the Ministry of Education, Science and Technological Development through the project no. 451-03-68/2020-14/200156: "Innovative scientific and artistic research from the FTS (activity) domain".

## REFERENCES

- [1] Brennan, R.B., Healy, M.G., Morrison, L., Hynes, S., Norton, D., Clifford, E., Management of landfill leachate: The legacy of European Union Directives, Waste Management, Vol. 55, pp. 355-363, 2015.
- [2] Bagchi, A.: Design of Landfills and Integrated Solid Waste Management, John Wiley & Sons, Inc., New Jersey, 2004.
- [3] Christensen, T.H., Cossu, R., Stegmann, R., Landfilling of Waste: Leachate, Elsevier Science Publishers Ltd., London, 1992.

- [4] Christensen, J.B., Jensen, D.L., Filip, Z., Gron, C., Christensen, T.H., Characterization of the dissolved organic carbon in landfill polluted groundwater, *Water Research*, Vol. 32 (1), pp. 125-135, 1998.
- [5] Kjeldsen, P., Barlaz, M.A., Rooker, A.P., Baun, A., Ledin, A., Christensen, T.H., Present and long-term composition of MSW landfill leachate: A Review, *Critical Review in Environmental Science and Technology*, Vol. 32 (4), pp. 297-336, 2002.
- [6] Maier, R.M., Pepper, I.L., Gerba, C.P.: *Environmental Microbiology*, Academic Press, San Diego and London, 2000.
- [7] Parte, A. C., LPSN—list of prokaryotic names with standing in nomenclature, *Nucleic Acids Research*, Vol. 42, pp. 613-616, 2014.
- [8] Huang, L.-N., Zhou, H., Chen, Y.-Q., Luo, S., Lan, C.-Y., Qu, L.H., Diversity and structure of the archaeal community in the leachate of a full-scale recirculating landfill as examined by direct 16S rRNA gene sequence retrieval, *FEMS Microbiology Letters*, Vol. 214, pp. 235-240, 2002.
- [9] Wei, L., Zhou, Q., Tao, H., Removal of Organic Matter from Landfill Leachate by Advanced Oxidation Processes: A Review, *International Journal of Chemical Engineering*, Vol. 2010, pp. 1-11, 2010.
- [10] Krishnamurthi, S., Chakrabarti, T., Diversity of Bacteria and Archaea from a landfill in Chandigarh, India as revealed by culture-dependent and culture-independent molecular approaches, *Systematic and Applied Microbiology*, Vol. 36, pp. 56-68, 2013.
- [11] Pérez-Leblic, M.I., Turmero, A., Hernández, M., Hernández, A.J., Pastor, J., Ball, A.S., Rodríguez, J., Arias, M.E., Influence of xenobiotic contaminants on landfill soil microbial activity and diversity, *Journal of Environmental Management*, Vol. 95, pp. 285-290, 2012.
- [12] Buchroithner, D., *Microbiology of Landfill Sites: Review of the present State of Knowledge with particular Focus on the Carbon Cycle*, Master thesis, University of Natural Resources and Life Sciences, Vienna, 2015.
- [13] Cardinali-Rezende, J., Debarry, R.B., Colturato, L.F.D.B., Carneiro, E.V., Chartone-Souza, E., Nascimento, M.A., Molecular identification and dynamics of microbial communities in reactor treating organic household waste, *Applied Microbiology and Biotechnology*, Vol. 84, pp. 777-789, 2009.
- [14] Collins, H.C., Kennedy, A.D., The microbiological hazards of municipal and clinical wastes: A review, *Journal of Applied Bacteriology*, Vol. 73, pp. 1-6, 1992.
- [15] Flores-Tena, J.F., Guerrero-Barrera, L.A., Avelar-González, J.F., Ramírez-López, M.E., Ma. Martínez-Saldaña, C., Pathogenic and opportunistic Gram-negative bacteria in soil, leachate and air in San Nicolás landfill at Aguascalientes, Mexico, *Revista Latinoamericana de Microbiología*, Vol. 49 (1-2), pp. 25-30, 2007.
- [16] Borquaye, S.L., Ekuadzi, E., Darko, G., Ahor, S.H., Twumwah Nsiah, S., Asi Lartey, J., Mutala, H.-A., Etsiapa Boamah, V., Woode, E., Occurrence of Antibiotics and Antibiotic-Resistant Bacteria in Landfill Sites in Kumasi, Ghana, *Journal of Chemistry*, Vol. 2019, pp. 1-10, 2019.
- [17] Wanger, A., Chavez, V., Huang, P.S.R., Wahed, A., Actor, K.J., Dasgupta, A.: *Microbiology and Molecular Diagnosis in Pathology*, Elsevier Science Publishing Co. Inc., USA, 2017.
- [18] Gregova, G., Kmet, V., Antibiotic resistance and virulence of *Escherichia coli* strains isolated from animal rendering plant, *Scientific Reports*, Vol. 10, pp. 1-7, 2020.
- [19] Navnon-Venezia, S., Kondratyeva, K., Carattoli, A., *Klebsiella pneumoniae*: a major worldwide source and shuttle for antibiotic resistance, *FEMS Microbiology Reviews*, Vol. 41(3), pp. 252-275, 2017.
- [20] Liu, L., Chen, D., Liu, L., Lan, R., Hao, S., Jin, W., Sun, H., Wang, Y., Liang, Y., Xu, J., Genetic Diversity, Multidrug Resistance, and Virulence of *Citrobacter freundii* From Diarrheal Patients and Healthy Individuals, *Frontiers in Cellular and Infection Microbiology*, Vol. 8, pp. 1-10, 2018.



## RELATIONSHIP BETWEEN AIR QUALITY AND DISTRIBUTION OF LICHENS AS BIOINDICATORS IN SOME SERBIAN LOCATIONS

Doris Stojilkovic<sup>1</sup>, Bogdana Vujic<sup>2</sup>, Hosam E.A.F. Bayoumi Hamuda<sup>1</sup>

<sup>1</sup>Institute of Environmental Engineering and Natural Sciences, Óbuda University, Rejtő Sándor Faculty of Light Industry and Environmental Engineering, Budapest, Hungary

<sup>2</sup>University of Novi Sad, Technical Faculty “Mihajlo Pupin”, Zrenjanin, Serbia

e-mail: [stojilkovicdoris0310@gmail.com](mailto:stojilkovicdoris0310@gmail.com), [bogdana.vujic@tfzr.rs](mailto:bogdana.vujic@tfzr.rs), [Bayoumi.hosam@uni-obuda.hu](mailto:Bayoumi.hosam@uni-obuda.hu)

**Abstract:** Over recent decades, air quality has become environmental problem worldwide due to industrial activities and road traffic. Atmospheric monitoring has been necessary to control air quality and reduce pollution sources. Air quality is a topic that attracts more and more attention especially with the problem of human health. Biomonitoring is based on the detection and monitoring of changes that occur on different levels of the biological organization for living organisms under the influence of air pollutants. It was noted that not all lichen species are equally likely to indicate different levels of air pollution. The assessment of lichen biodiversity was based on the calculation of lichenic abundance indices. This research work deals with using lichens as a bioindicators of the air quality and it was conducted from various Serbia locations. Also, it is shown the relationship between the Serbian air qualities, and how lichens act as a bioindicator for the air quality, in some parts of Serbia such as in Sremska Mitrovica city, Fruska Gora mountine, Palic Lake and Silver Lake.

The bioanalysis of the samples from investigated sites indicates the presence of different lichen taxa, which shows that these sites are rich in lichen species. Information about the air quality index of Zrenjanin city as an example of the Serbian cities which demonstrates the chemical pollutants, climate changes for example weather, wind and temperature This work also shows the distribution of the lichens which can be found in the investigated sites. The presence of lichen indicates that the air quality in these sites: Sremska Mitrovica city, Fruska Gora mountine, Palic Lake and Silver Lake is quite good. It was concluded that the presence of epiphytic lichens plays an important role in determining the air pollution in those sites. By the presence of these lichens, we have found that the most dominant lichen taxa were *Rhizocarpon geographicum*, *Lecanora muralis*, *Lecanora muralis*, *Rhizocarpon geographicum*, *Xanthoria parietina* and *Xanthoria candelaria*.

**Keywords:** air quality; bioindication; lichen biodiversity

### INTRODUCTION

Air pollution is one of the biggest and most important risk factors for health in the world. Worldwide approximately 7 million people died prematurely due to the pollution; within the European countries 400,000 people suffer a premature death. [1]

The substances that are affecting health the most are: nitrogen oxides (NO<sub>2</sub>), sulphur oxides (SO<sub>2</sub>), ozone and particulate matter with the latter – especially particulate matter below 2.5 microns (PM<sub>2.5</sub>) – being of greatest concern, as these tiny particles penetrate deep into the lungs, affecting both the respiratory and vascular systems. Both extent and duration of the exposure influence health outcomes. The impact of air pollution on health is a big concern as research shows more connection between a number of serious diseases among various age groups and air pollution (e.g. diabetes, neurodevelopment, pre-term birth, low weight birth, etc.).

According to the results of the air quality monitoring, Serbia is one of the most polluted countries in Europe and worldwide. Pollution in Serbia is in general, really high in past few years. Serbia's air pollution comes from a variety of sources, with Serbia's reliance on lignite and coal-fuelled power plants being a well-known cause of the energy sector in addition to burning solid fuels (such as coal and wood) to heat homes. Pollutant emissions from an aging transport fleet, industrial activities, landfills and emissions from agriculture make a significant contribution to this. The specific industrial sites that have been documented as causing air pollutants in Serbia include the petrochemical complex around the cities of Pančevo and Novi Sad for example. The level of air pollution from different sources varies in different areas of Serbia. For example, in large urban areas such as Belgrade, Novi Sad and Niš, road traffic is a significant contributor to urban air pollution and increases. The emissions

in Serbia are largely attributed to the country's relatively old vehicle fleet, with an average car in the country estimated at 17 years. [2]

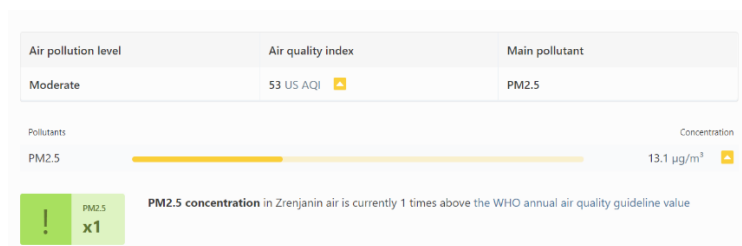
### AIR QUALITY INDEX

As in Table 1, the air quality index is used to report daily air quality. It is used to find information of how the air is polluted, or clean, also which health effects might be of a concern in that place. [3]

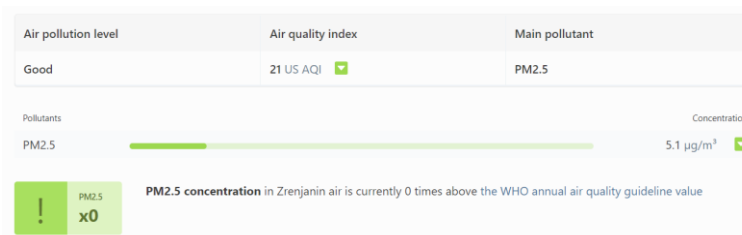
**Table 1: Air Quality Index information**

Air Quality Index (Aqi) Values	Levels Of Health Concern	Colours
AQI RANGE:	Air Quality Conditions	Symbolized By Colour:
0-50	Good	Green
51-100	Moderate	Yellow
101-150	Unhealthy For Sensitive Groups	Orange
151-200	Unhealthy	Red
201-300	Very Unhealthy	Purple
301-500	Hazardous	Maroon

As in Figures (1 and 2), based on IQAir's "2019 World Air Quality Report", which aggregated air quality data for over 4000 cities globally, Serbia ranked as the 32<sup>nd</sup> most polluted country worldwide, of a list of 98 ranked countries for PM<sub>2.5</sub> pollution. [2] The country's annual average PM<sub>2.5</sub> concentration, when weighted by population, emerged as 23.3 µg/m<sup>3</sup>, which represents a twofold exceedance of the World Health Organization (WHO)'s international guideline limit for PM<sub>2.5</sub> as 10 µg/m<sup>3</sup>. [4]



**Fig. 1. AQI Zrenjanin during the Summer (August 2021) [5]**



**Fig. 2. AQI Zrenjanin (September 2021) [5]**

In the Figures above, it is shown that the Air Quality Index (AQI), on first one in August 2021 (data found during the day), and on second report from the September 2021 (data found during the night). AQI values can be varied depending on the time of day.

Fine particulate matter (PM<sub>2.5</sub>) is an air pollutant that may be a difficulty for popular health when its level in air is high. PM<sub>2.5</sub> is tiny particle with inside the air that reduces visibility and it is a reason for air to seem hazy while levels are increased. Outdoor PM<sub>2.5</sub> levels are maximum probable to be increased on days with very little or no wind or air mixing. The New York State Departments of Health (DOH) and Environmental Conservation (DEC) alert the general public through issuing a PM<sub>2.5</sub> Health Advisory whilst PM<sub>2.5</sub> concentrations in outdoor air are predicted to be dangerous for touchy groups.

There are outdoor and indoor sources of fine particles. Outside, fine particles in most cases come from car, truck, bus and off-road vehicle (e.g., construction equipment, snowmobile, locomotive) exhausts, different operations that contain the burning of fuels inclusive of wood, heating oil or coal and natural sources inclusive of wooded area and grass fires. Fine particles additionally form from the response of gases or droplets with inside the surroundings from sources inclusive of power plants. These chemical reactions can arise miles from the authentic supply of the emissions. Some indoor sources of fine particles are tobacco smoke, cooking (e.g., frying, sautéing, and broiling), burning candles or oil lamps, and operating fireplaces and fuel-burning space heaters (e.g., kerosene heaters). [7]

Particles in the  $PM_{2.5}$  size range are able to travel deeply into the respiratory tract, reaching the lungs. Exposure to fine particles can cause short-term health effects such as eye, nose, throat and lung irritation, coughing, sneezing, runny nose and shortness of breath. Exposure to fine particles can also affect lung function and worsen medical conditions such as asthma and heart disease. Scientific studies have linked increases in daily  $PM_{2.5}$  exposure with increased respiratory and cardiovascular hospital admissions, emergency department visits and deaths. Studies also suggest that long term exposure to fine particulate matter may be associated with increased rates of chronic bronchitis, reduced lung function and increased mortality from lung cancer and heart disease. People with breathing and heart problems, children and the elderly may be particularly sensitive to  $PM_{2.5}$  (Figure 3).

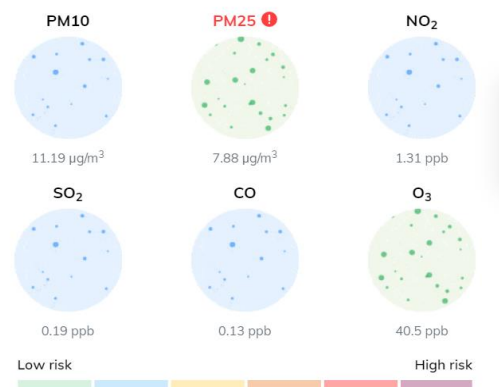


Fig. 3. Chemical pollutants in Zrenjanin

## AIR POLLUTION IN SERBIA AND ZRENJENIN (CHEMICAL POLLUTANTS)

### AIR Pollutants:

**Ozone ( $O_3$ ):**  $O_3$  is a powerful oxidant and has many industrial and consumer applications related to oxidation. It can damage mucous and respiratory tissues in animals, and plants.

### Particulate matters:

**$PM_{10}$ :** Inhalable particles, with diameters that are generally 10  $\mu\text{m}$  and smaller. These particles come in many sizes and shapes and can be made up of hundreds of different chemicals.

**$PM_{2.5}$ :** Inhalable particles, with diameters that are generally 2.5  $\mu\text{m}$  and smaller. Some are emitted directly from a source, such as construction sites, unpaved roads, fields, smokestacks or fires.

**Carbon monoxide (CO):** CO is a colourless, odourless gas that can be dangerous when inhaled in large amounts. Sources of CO are cars, trucks and other vehicles or machinery that burn fossil fuels.

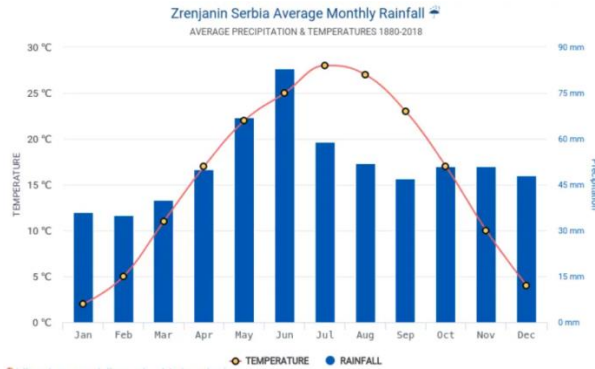
**Sulfur Dioxide ( $SO_2$ ):**  $SO_2$  is one of a group of gases called sulfur oxides. The largest source of  $SO_2$  in the atmosphere is the burning of fossil fuels by power plants and other industrial facilities.

**Nitrogen dioxide ( $NO_2$ ):**  $NO_2$  primarily gets in the air from the burning of fuel.  $NO_2$  forms from emissions from cars, trucks and buses, power plants, and off-road equipment.” [6]

## CLIMATE CHANGES IN ZRENJANIN (IN LIMITED TIME)

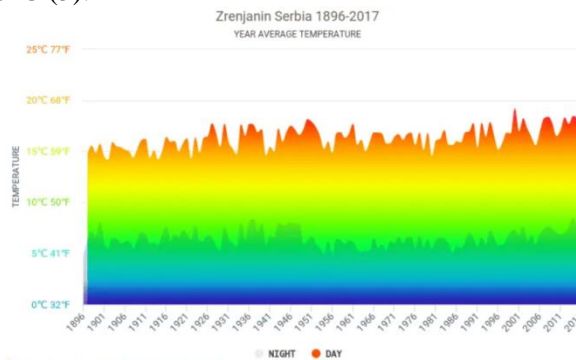
Figure 4 shows those months with the largest precipitation are June, May, July with 209 mm precipitation. Most precipitation occurs in June with an average precipitation 83 mm. The annual

amount of precipitation in Zrenjanin is 619 mm. The average annual temperature is 16°C in Zrenjanin. The warmest month of the year is July, with an average temperature: 28°C. January is the coldest month in Zrenjanin, with average temperature 2°C. The difference between the hottest month: July and the coldest month: January is: 26°C. The difference between the highest precipitation (June) and the lowest precipitation (February) is 48mm. The lowest temperature recorded (monthly average) was -10°C in February 1956 in Zrenjanin. The highest temperature recorded (monthly average) was 26°C in August 1992 in Zrenjanin. The year 2017 was the warmest in Zrenjanin, average temperature was: 14°C. 1956 was the coldest year (Figure 5), with average temperature was: 10°C. [8]



**Fig. 4.** Climograph of monthly averages climate data temperature and precipitation in Zrenjanin, a basic climate data set 1880-2018 for Zrenjanin [8]

In Zrenjanin, in general, summers are warm, the winters are dry and cold, and during the year is usually partly cloudy. Over the year, the temperature was variants from 2°C to 28°C, and it rarely goes under -10°C and above 33°C (5).



**Fig. 5.** Average temperature in Zrenjanin over the years . Average Weather in Zrenjanin, Serbia Climatological information about changes of temperature over the years in Zrenjanin

Figures 6 and 7 illustrate the different climatic parameters such as temperature, relative humidity and wind as well as the PM<sub>2.5</sub> and PM<sub>10</sub> at various times, August and September, respectively.

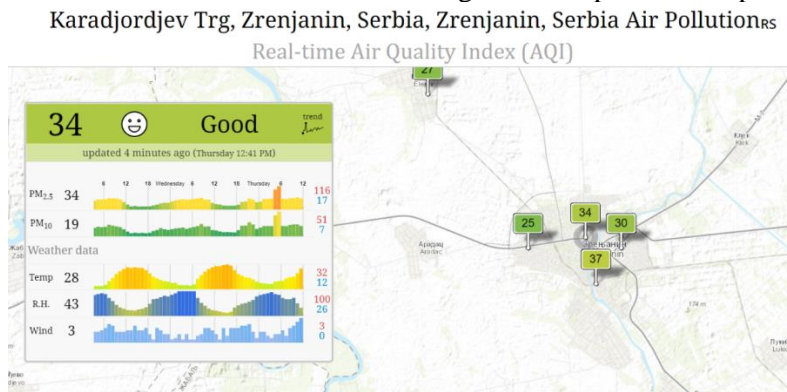


Fig. 6. Data in Zrenjanin in Summer time (August)

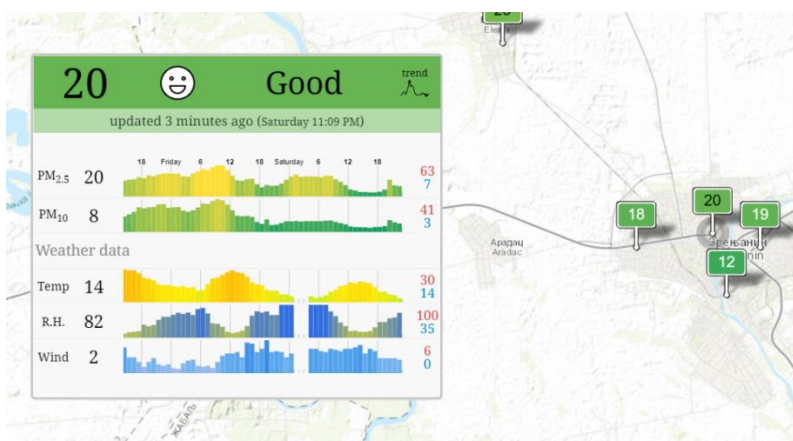


Fig. 7. Data about Zrenjanin, in September [9]

Such a picture of the different air pollution levels in Zrenjanin is a logical consequence of air pollution and the mixed influence of microclimate, substrate and geo-physical features, as well as the distribution of “green” areas and objects. According to the qualitative and characterization of lichens, a qualitative assessment of lichen sensibility to air pollution has been made.

#### LICHENS AS AIR BIOINDICATORS IN SERBIA

Lichens are presently taken into consideration to be fungi that live in symbiosis with a photobiont, an autotrophic green alga (phycobiont), or cyanobacterium (cyanobiont) or, in a few cases, both. This symbiotic life and relationship is characterized as mutualism, which means that both organisms have some benefits. Generally, it's thought-about that the most reasons for categorization of lichens as vulnerable organisms are disappearance and contamination of their environments primarily caused by humans, because of pollution of the atmosphere, industrialized agriculture, unfavourable biology practices and phylogeny alterations of huge habitat areas. All of those problems have led to the degradation of lichen habitats. In Serbia there are currently around 586 species of lichens. [10]

Lichens are used as an environmental biological indicator or the bioindicators for the pollution worldwide. In case that air is a lot polluted with for example  $\text{SO}_2$ , there won't be any presents of lichen, only the green algae can be found. Because of their sensitivity to  $\text{SO}_2$  they can be considered, and used as a bioindicators of air quality and pollution. On the other hand, in case that air is clean, and air quality is good, lichens become abundant, which means that in absence of pollution, lichens are presence. If the lichens are smaller and less variety, environment in more polluted. Lichens are sensitive to atmospheric pollution because they get their nutrients and water from wet and dry atmospheric deposition. [11]

Based on the sizes of lichens, they can be classified in two groups: Microlichens and Macrolichens.

**Microlichens:** are really small, and not so easily defined because of impossibility of seeing their structure and physical characteristic with the naked eye.

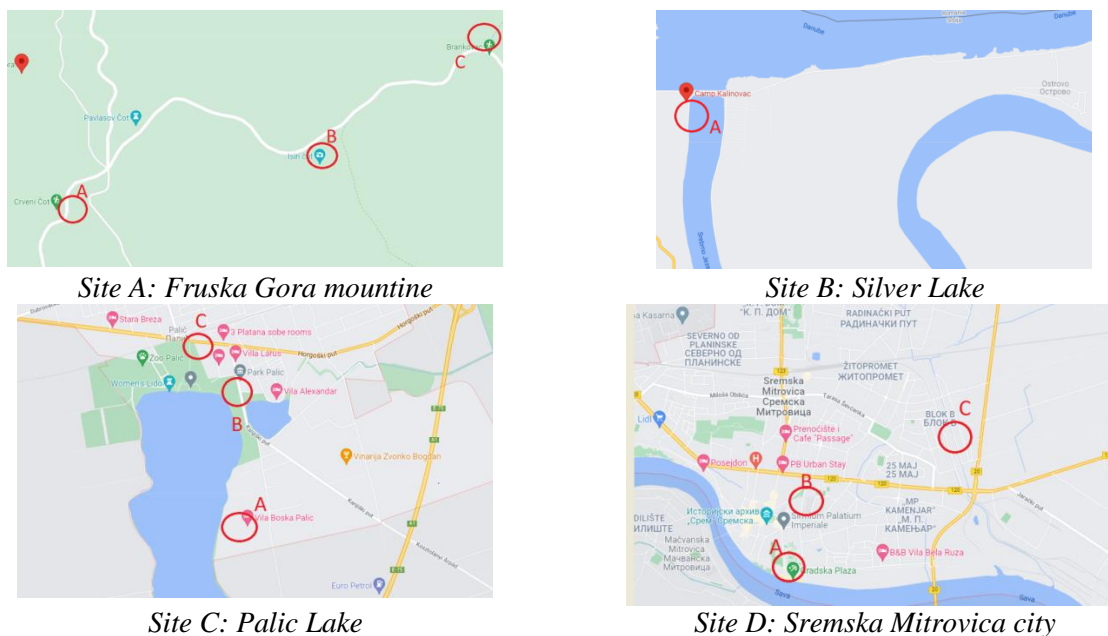
**Macrolichens:** Because of their size, they can be easily defined and observed only with the naked eye.

Based on their growth forms lichens can be: Crustose, Folios and Fruticose, and on the basis of substrate on which they grow, they can be classified as: Corticoloua, Ramicolous, Legnicolous, Saxicolous, Musicolous, Terricolous, and Follicolous. Methods which can be used for identification of lichens are:

- Microscopic Approaches: Morphology, Anatomy
- Chemical Approaches: Colour spot test, TLC, HPTLC, HPLC
- Molecular Approaches: PCR genotyping and DNA Barcoding [12]

## MATERIALS AND METHODS

Sites of collecting samples: The lichen samples were collected from four different climatic and topological conditions sites: Site A: Fruska Gora mountine, Site B: Silver lake, Site C: Palic lake and Site D: Sremska Mitrovica city as shown in the Figure (8).



**Fig. 8.** The sites of lichen samples collections presented by red circles

Lichen samples in Sremska Mitrovica city, Fruska Gora mountine, Palic Lake and Silver Lake were collected from different trunk of various trees at different locations. The investigated sites are located in the urban part of Sremska Mitrovica, starting from the centre of town and close to Sava River (Figure 8).

## RESULTS AND DISCUSSION

At four investigated sites, various lichen taxa from different genera were found. The most frequent and dominant as well as common taxa in these four sites of collections were *Rhizocarpon geographicum*, *Lecanora muralis*, *Lecanora muralis*, *Rhizocarpon geographicum*, *Xanthoria parietina* and *Xanthoria candelaria*.

The presence of lichens indicates that the air quality of the study sites (Sremska Mitrovica city, Fruska Gora mountine, Palic Lake and Silver Lake) which it illustrated a quite good. Also, it was concluded that the presence of epiphytic lichens plays an important role in determining the different degree in air quality. The following Figures (from 9 to 13) will demonstrate some common samples of collected lichens in the investigated sites.

### Sample collection of lichens from Fruska Gora mountine site



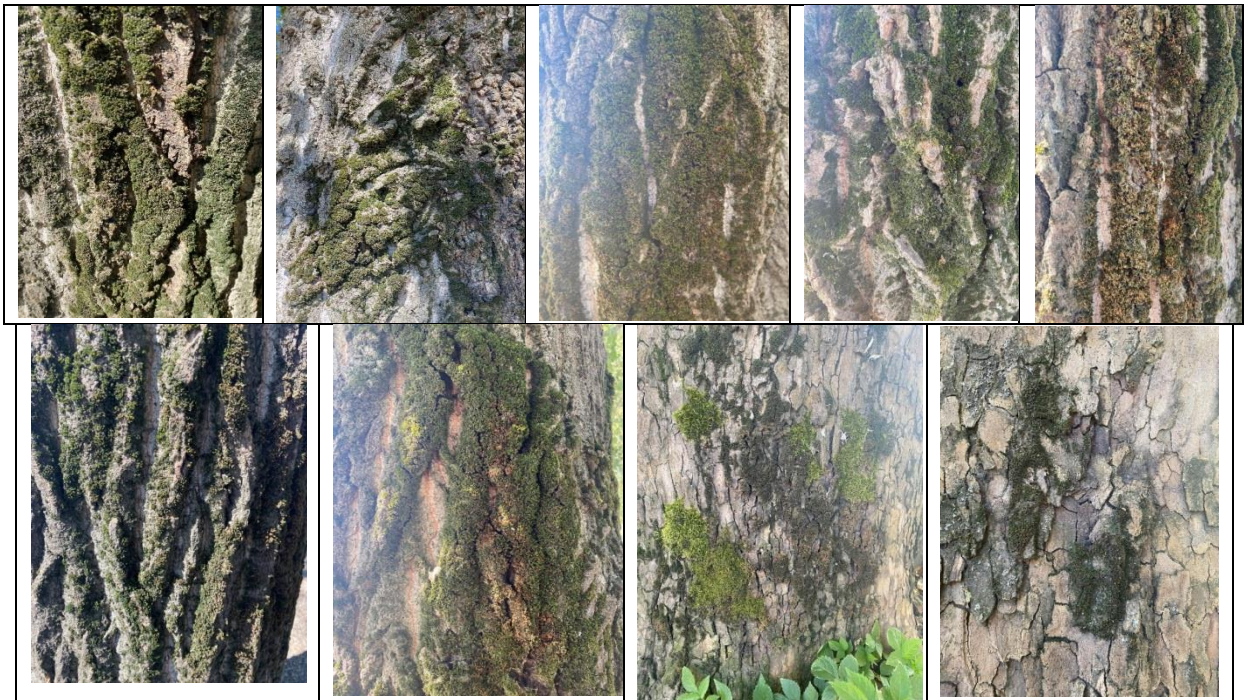
**Fig. 9.** Lichens in Fruska Gora mountine

**Sample collection of lichens from Sremsks Mitrovica town site**



**Fig. 10.** Lichen semples from Sremsks Mitrovica town

**Sample collection of lichens from Sava River in Sremska Mitrovica site**



**Fig. 11.** Lichens near Sava River in Sremska Mitrovica

**Sample collection of lichens from Palic Lake site**



Fig. 12. Lichens close to Palic Lake

#### Collection of lichens from Silver Lake site



Fig. 13. Lichens close to Silver Lake

Generally among the distribution of lichens throughout the four collected sites, the Site A: Fruska Gora mountine contained the highest amount of lichens. The distributions of lichens at the Site D: Sremska Mitrovica city were differentially found between the collected points. The C point showed the lowest lichens content than the other two points. A point was the site where the highest lichen population is found. Finally, it was found that the distribution of lichens at Site D: Sremska Mitrovica city was lower than in others sites. So, high ambient concentrations of pollutants have been associated by international epidemiological studies with various negative health impacts.

#### CONCLUSIONS

The areas from where lichens samples were collected are urban settlement and without much and large industry and traffic. A bioindication and physical-chemical investigation of air pollution in Zrenjanin has not been completed yet. At different investigated sites a lot of lichen taxa were collected from various genera. The most frequent lichen taxa are: *Rhizocarpon geographicum*, *Lecanora muralis*, *Lecanora muralis*, *Rhizocarpon geographicum*, *Xanthoria parietina* and *Xanthoria candelaria*. The presence of lichen indicates that the air quality in these sites (Sremska Mitrovica city, Fruska Gora mountine, Palic Lake and Silver Lake) is quite good. It was concluded that the presence of epiphytic lichens plays an important role in determining and distinguish between the air pollution at the different areas of collections



## REFERENCES

- [1] <https://www.balcanicaucaso.org/eng/Areas/Serbia/Serbia-Europe-s-most-polluted-country-199149>
- [2] <https://www.iqair.com/serbia>
- [3] <https://www.weather.gov/safety/airquality-aqindex>
- [4] <https://waqi.info/#/c/7.163/8.919/2.3z>
- [5] <https://www.iqair.com/serbia/autonomna-pokrajina-vojvodina/zrenjanin>
- [6] <https://www.tomorrow.io/weather/RS/VO/Zrenjanin/097450/health/>
- [7] [https://www.health.ny.gov/environmental/indoors/air/pmq\\_a.htm](https://www.health.ny.gov/environmental/indoors/air/pmq_a.htm)
- [8] <http://hikersbay.com/climate-conditions/serbia/zrenjanin/climate-conditions-in-zrenjanin.html?lang=en>
- [9] <https://aqicn.org/station/serbia/zrenjanin/karadjordjev-trg>
- [10] "Lichens in Serbian legislation" Boris N. Ivancevic, Milan N. Matavulj, Maja A. Karaman, 2013 <http://www.doiserbia.nb.rs/img/doi/0352-4906/2013/0352-49061324355I.pdf>
- [11] <http://www.air-quality.org.uk/19.php>
- [12] "Advancements in Methods Used for Identification of Lichens" Sachin Singh, Mamta Arya and Shailesh Kumar Vishwakarma <https://www.ijcmas.com/abstractview.php?ID=14040&vol=8-8-2019&SNo=169>

## BIOINDICATION OF AIR QUALITY USING LICHEN IN ULAANBAATAR, MONGOLIA

Tsend-Ayush Erdenejargal<sup>1</sup>, Enkhtuya Ochirbat<sup>2</sup>, Hosam E.A.F. Bayoumi Hamuda<sup>1</sup>

<sup>1</sup>Institute of Environmental Engineering and Natural Sciences, Óbuda University, Rejtő  
Sándor Faculty of Light Industry and Environmental Engineering, Budapest, Hungary

<sup>2</sup>Laboratory of Flora and Plant systematics, Botanical Garden and Research Institute,  
Mongolian Academy of Sciences, Ulaanbaatar-13330, Mongolia

e-mail: [Bayoumi.hosam@uni-obuda.hu](mailto:Bayoumi.hosam@uni-obuda.hu)

**Abstract:** Lichen is a composite organism that arises from green algae or cyanobacterium (phycobiont) and fungal partner belongs to the Ascomycota and Basidiomycota (mycobiont), living together in symbiotic relationship. The interaction between lichens and air pollution has been used as a means of monitoring air quality since 1859. The most important pollutant was sulphur dioxide produced by coal burning industry and power stations. City of Ulaanbaatar, the capital of Mongolia was initially designed for a half million residents. Due to intense rural-to-urban migration after transition to market driven economy, the population of the capital is nearly tripled, which resulted in huge area of informal settlements and elevated number of vehicles. Tents and small buildings in above settlements heated by conventional stoves by burning coal and wood, while the most vehicles on the road are imported second-hand cars. During last two decades, air quality of capital city Ulaanbaatar is considered as an emerging issue and above two are primary sources of outdoor air pollution. The most abundant air pollutants are nitrogen dioxide (NO<sub>2</sub>), sulfur dioxide (SO<sub>2</sub>) and carbon monoxide (CO) which have disastrous effects on health when inhaled over prolonged periods of time. Due to the quantities of these pollutants would be far more abundant and thus cause the catastrophic effects to the air quality that is seen in Ulaanbaatar. Various techniques have been developed to monitor air quality, including biomonitoring using lichens. In this study, we monitored types of epiphytic lichens covering sensitive to air pollution fruticose type and relatively tolerant foliose type of lichens. Unlike air quality index, lichens clearly show negative impact of poor air quality on surrounding ecosystems. We examined lichens on *Larix sibirica*, the most abundant coniferous tree of the area. Both foliose and fruticose types of lichens are abundant in *Larix sibirica* dominated forests located to the northern areas of Ulaanbaatar. It indicates the area is free of pollution. In contrary, fruticose type lichens, especially representatives from the genera *Usnea*, *Cladonia* and *Vulpicidia* are absent in coniferous forest to the southern areas of Ulaanbaatar. These results clearly show downwind ecosystems have been badly affected by poor quality air of the capital. Additionally, there is none of those bark dwelling lichens are observed on the three along the crowded roads, parks and residential areas which indicates the extreme pollution of the air. Finally, biomonitoring using lichen as the bioindicator is discussed, and future recommendation is provided in the end of the study.

**Keywords:** Anthropogenic activities, air quality of Ulaanbaatar, Mongolia, lichens, bioindicator

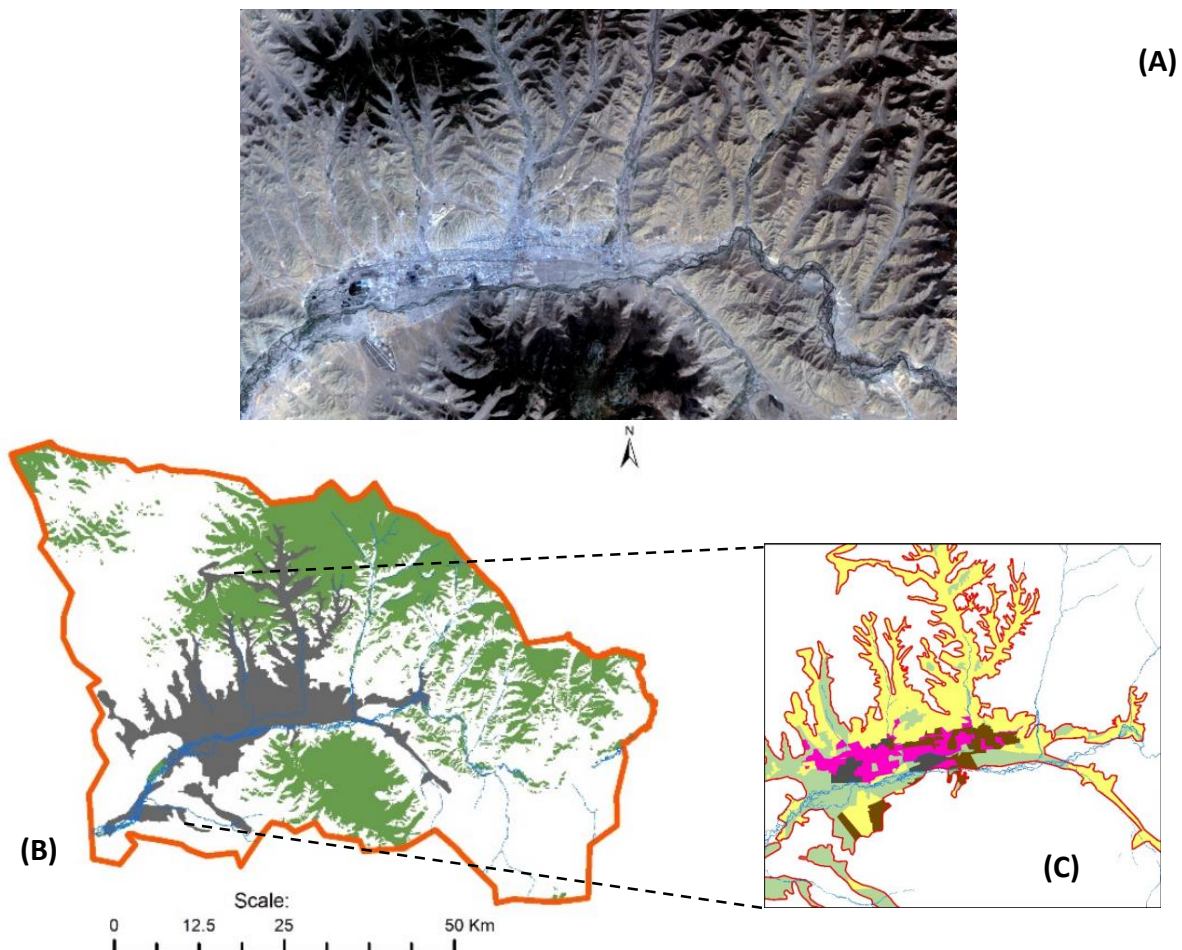
### INTRODUCTION

Lichens are mutualistic associations of a fungus and an algae or cyanobacterium. In nature, they occur on rocks, bare grounds, and trees, the latter known as epiphytic lichens. Due to their dependence on airborne nutrients, lichens are very sensitive to air pollution especially to sulfur dioxide. They do not bear defensive tissue, therefore quickly absorb, and accumulate sulfur dioxide in their tissue, which subsequently leads to a damage of chlorophyll in phycobiont algae so that photosynthesis is inhibited. Because of this sensitive characteristic, lichens are widely used as environmental indicators or bio-indicators. Depending on their degree of tolerance, some species may present with certain concentration of pollutants, while all species may vanish with extremely poor air quality. On this ground, lichens provide a relevant, sensitive, and measurable indicator for long-term monitoring (Das *et al.*, 2013; Giordani, 2007).

One of the places where lichens could be used as bio-indicator is city of Ulaanbaatar, the capital of Mongolia. The city is characterized by its high elevation (1350 meters above sea level), low precipitation (200-300 mm), and its location in a basin (Hauck, 2008). The city was initially designed for a half million residents. However, due to 1990s intense rural-to-urban migration, population of the capital was far more exceeded than its infrastructure capacity and ended up with informal settlements or huge ger areas (Figure 1). Since Ulaanbaatar is the coldest capital in the world with annual mean

temperature of minus 3.7°C (Hilbig et al., 2004), the major cause (c.a. 80%) of air pollution comes from coal burning stoves which are the sole way to heat ger homes under sub-zero temperatures. There are 130.5 thousand families in ger areas burn roughly 525 thousand metric tonnes of coals, 290 thousand cubic metres of firewood, and other combustible materials each year (<http://agaar.mn/static/stove-distribution>). As a result, concentrations of the major pollutants far outreached the guideline values provided by WHO. For example, on the coldest days of the year, daily average of PM<sub>2.5</sub> level reaches 687 µg/m<sup>3</sup>, which is 27 times higher than the level WHO recommends as safe (<https://www.unicef.org/mongolia/environment-air-pollution>). Similarly, sulphur dioxide, the major pollutant from coal burning reaches 170 µg/m<sup>3</sup>, which is eight times higher than a national air quality standard. The second major source (10%) of air pollution is 340 thousand vehicles on the road and most of which are (79%) aged more than ten years and with substandard quality. Total of three thermal power plants are responsible for 6% of Ulaanbaatar air pollution, and the rest 4% is windblown dust (Davy et al., 2011).

Supporting reason for dense air pollution of Ulaanbaatar is its geographical location in a basin. The city is located along the Valley of Tuul River. Surrounding mountains reduce vertical and horizontal dispersion of air pollutants, especially during wintertime (Figure 1). Polluted air accumulates in the city area and shows number of negative impacts on human and ecosystem health. Air quality of capital city Ulaanbaatar is considered as an emerging issue and dozens of measures taken during the last two decades; however, no significant improvements have been achieved so far.



**Fig. 1. Map of the city of Ulaanbaatar**

(A) Landsat image (<https://landsat.visibleearth.nasa.gov>); (B) Settlement areas of the city, where grey - settlement areas, green - forest areas, and blue - rivers; (C) Land use map as of 2010, where yellow - ger areas (Myagmartseren et al., 2018)

Study on lichens in relation with air quality started in mid 90s (Galsan et al., 1995; Enkhtuya, 1999) and further studies examined Ulaanbaatar air pollution effect on lichenous flora of surrounding

ecosystems, biochemical and chemical analysis of lichens, bio-indicator roles of local lichens and biodiversity of lichens (Ganbold et al., 2007; Hauck, 2008; Baljinnyam et al., 2009; Delgermaa et al., 2016).

In this study, we examined epiphytic lichens on *Larix sibirica*, the most abundant tree of the local forest at four sites close to Ulaanbaatar city. Two sites were chosen from Bogd Khan Mountain to the south and downwind of the city and two were from Chinggeltei Mountain to the north and upwind of the city. Both foliose and fruticose types of lichens were abundant at the sites to the northern areas of Ulaanbaatar. The result indicated the area was free of air pollution and wind flow prevent the area from pollution. In contrary, fruticose type lichens, especially representatives from the genera *Usnea*, *Cladonia* and *Vulpicidia* are absent in coniferous forest to the southern areas of Ulaanbaatar. Furthermore, relatively tolerant foliose type lichens show morphological changes such as size reduction, shape deformation and colour change or fading. This results clearly shows downwind ecosystems has been badly affected by poor quality air of the capital. Additionally, there were none of those bark dwelling lichens observed on the threes along the crowded roads, parks and residential areas which indicated the extreme pollution of the air within the city. Our result show that lichens could act as reliable and cost-effective bio-indicator which clearly differentiate mild or heavy pollution of the air. On the other hand, from the lichen community and their current biodiversity loss, we could foresee how antropogenic false activities may effect on other forms of life if pollution exposure lasts further.

## MATERIALS AND METHODS

**Study sites.** Total four sites were selected in this study. Site A and B located in Bogd Khan Mountain area which is to the south and downwind of the city. The Site A located at 1762 meters above sea level, where wind flows mostly from the west, rather not from the city. Site B was just 1.62 kilometers apart from Site A, however 298 meters below and located downwind the emission from Thermal Power Plant III. With this reason, the Site B was suspected as the most polluted site along with other three sites (Figure 2).

Site C and D were from Chinggeltei Mountain to the northern side and mostly upwind of the city. The Site C was chosen because its location along the Selbe River. During winter, when air pollution reaches its highest peak, the polluted air fills up the valley and reaches Site C if wind flow is weak. That is why we suspect this site to expose to mild pollution.

The last Site D was chosen because its distance from the source of pollution. All of the above four sites belonged to the same type of forest or coniferous forest where larch tree dominates (Figure 2). Details of the selected sites were given in Table 1.

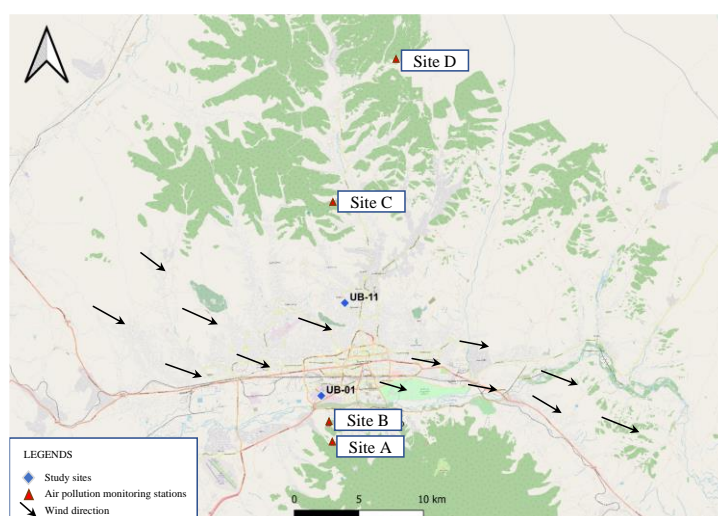


Fig. 2. Location of the selected sites

**Table 1. Details of the selected sites**

Site of study	Bogd Khan Mountain (downwind the city)		Chinggeltei Mountain (upwind the city)	
	Zaisan	Khiimoriin ovoo	Yargait	Khandgait
	Site A	Site B	Site C	Site D
Latitude	47°86'26.2"N	47°87'61.5"N	48°02'93.9"N	48°12'71.2"N
Longitude	106°88'28.6"E	106°87'91.7"E	106°88'90.8"E	106°95'85.8"E
Altitude	1782 m	1464 m	1545 m	1731 m
Distance from city center by road or path	8.6 km	7.0 km	14.7 km	26.9 km
Forest type	Coniferous	Coniferous	Coniferous	Coniferous

**Lichen sampling.** Siberian larch *Larix sibirica* was used in this study because of its abundance and morphological characteristics of bark that is rough and suitable for lichen settling. Lichen colonies were collected with the help of forceps, placed in sample bags and transferred to a laboratory.

#### Identification of lichens

Lichen specimen was collected in polyethylene bags and transferred to a laboratory. The samples were air dried and identified using light microscopy with the help of chemical tests (Orange et al., 2010).

**Total lichen coverage.** Total fifteen individual larch trees, whose diameters  $\geq 20$  cm were selected at each site. Quantification of lichens was done by placing a lichen grid (20X20 cm) on the tree at 0-20 cm and 130-150 cm heights from ground level (Enkhtuya, 2007).

## RESULTS AND DISCUSSIONS

**Lichen diversity.** Currently there are 225 species of lichen recorded in Bogd Khan Mountain (Enkhtuya, 2007). However, in this study, we recorded collectively 12 lichen species at the A and B sites selected from Bogd Khan Mountain area (Table 2); 10 and 8 species from the Site A and B, respectively. Most lichens observed from Bogd Khan Mountain belonged to foliose and crustose growth types which are relatively tolerant to air pollution.

For example, according to Hawksworth, 1970, foliose type lichen *Hypogymnia physodes* could tolerate  $70\mu\text{g}/\text{m}^3$  mean winter  $\text{SO}_2$  concentration and appear around the basis of the trees, but do not extend up the trunks. In our study, mostly all sensitive species from fruticose type lichens were vanished and foliose type species - *Hypogymnia physodes*, *Flavopunctelia soledica* and *Parmelia sulcata* were observed as dominant lichens mostly around the basis of the trees. Especially, two tolerant species *Flavopunctelia soledica* and *Parmelia sulcata* comprised more than 90% of the total lichen coverage at the Site B.

From fruticose growth type, only one species - *Evernia mesomorpha* was observed in this area. To note, only one colony of *Evernia mesomorpha* was recorded among fifteen larch trees used at the Site B.

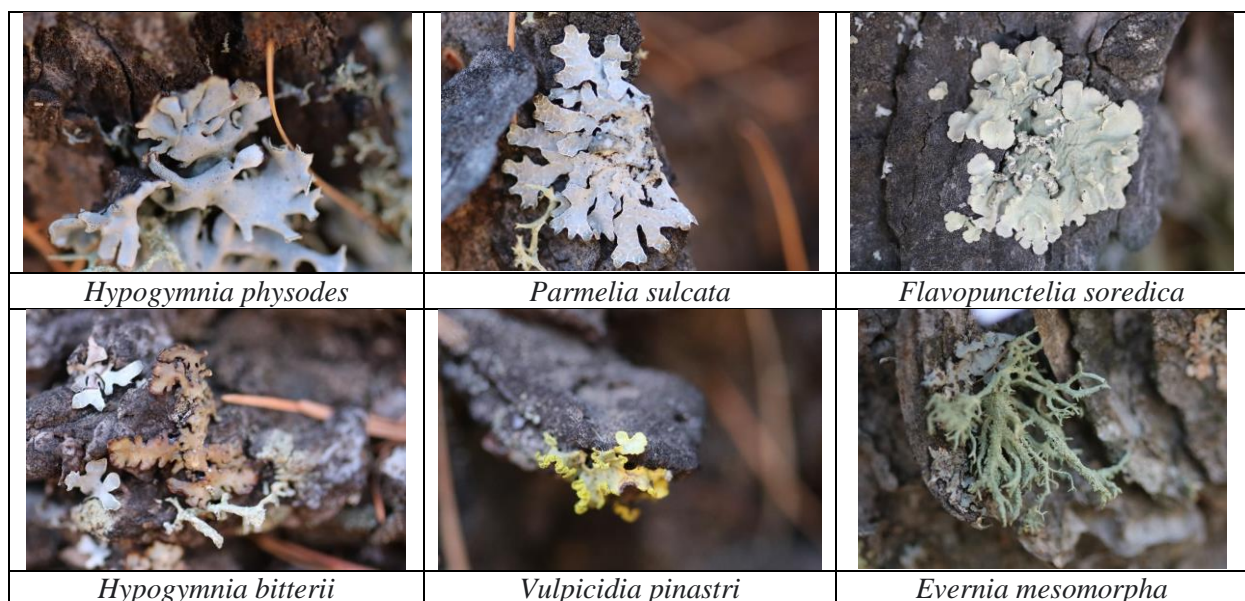
For the two sites C and D from Chinggeltei Mountain area, upwind the city, the most sensitive fruticose type lichen species were observed as abundant lichens (Table 2). Well known bio-indicator species from a genus *Usnea*, which exist when mean winter sulfur dioxide concentration is below  $40\mu\text{g}/\text{m}^3$  only were observed at both Sites C and D. Furthermore, golden-colored foliose type lichen *Vulpicidia pinastri*, which is extremely sensitive to any type of air pollution, was recorded at Site D. This result indicated an excellent air quality at this site.

**Table 2. Lichen species recorded at each study site.**

Species	Morphology	Bogd Khan Mountain		Chinggeltei Mountain	
		Site A	Site B	Site C	Site D
<i>Cladonia coniocraea</i>	Fruticose			+	+
<i>Cladonia fimbriata</i>	Fruticose			+	+
<i>Evernia mesomorpha</i>	Fruticose	+	+	+	+
<i>Usnea fulvoreaegens</i>	Fruticose			+	+
<i>Usnea hirta</i>	Fruticose			+	+
<i>Usnea lapponica</i>	Fruticose				+
<i>Usnea sp.</i>	Fruticose				+
<i>Flavopunctelia soledica</i>	Foliose	+	+	+	+
<i>Hypogymnia bitterii</i>	Foliose	+		+	+
<i>Hypogymnia physodes</i>	Foliose	+	+	+	+
<i>Melanelia exasperatula</i>	Foliose	+			+
<i>Melanelia olivacea</i>	Foliose			+	+
<i>Parmelia soledica</i>	Foliose		+	+	+
<i>Parmelia sulcata</i>	Foliose	+	+	+	+
<i>Vulpicidia pinastri</i>	Foliose				+
<i>Buellia sp.</i>	Crustose			+	+
<i>Lecanora piniperda</i>	Crustose	+			+
<i>Lecanora symmicta</i>	Crustose			+	+
<i>Lepraria sp.</i>	Crustose	+			+
<i>Rinodina sp.</i>	Crustose			+	+
<i>Trapeliopsis flexuosa</i>	Crustose	+	+	+	+
<i>Trapeliopsis granulosa</i>	Crustose		+		+
<i>Hypocenomyce scalaris</i>	Squamulose	+	+		
	<b>Total</b>	<b>10</b>	<b>8</b>	<b>15</b>	<b>22</b>

+ present

We collected and identified total 22 species of lichens from Chinggeltei area; 15 and 22 species from the Site D and C, respectively. Some of the lichens were photographed and shown in Figure (3).



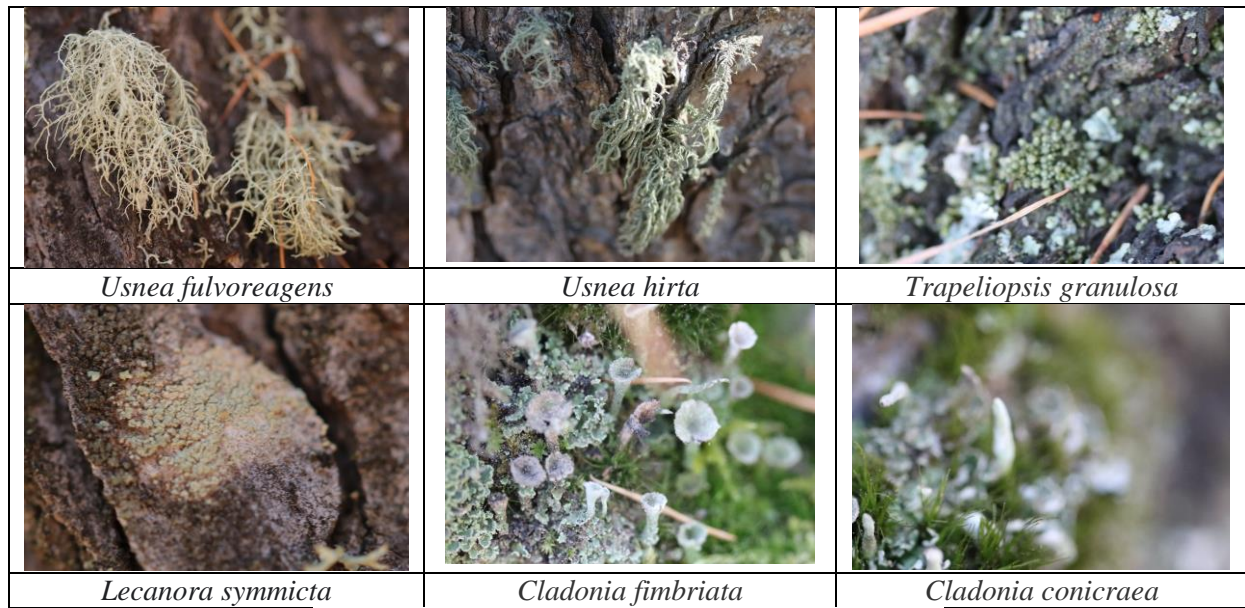


Fig. 3. Lichen species observed near Ulaanbaatar city

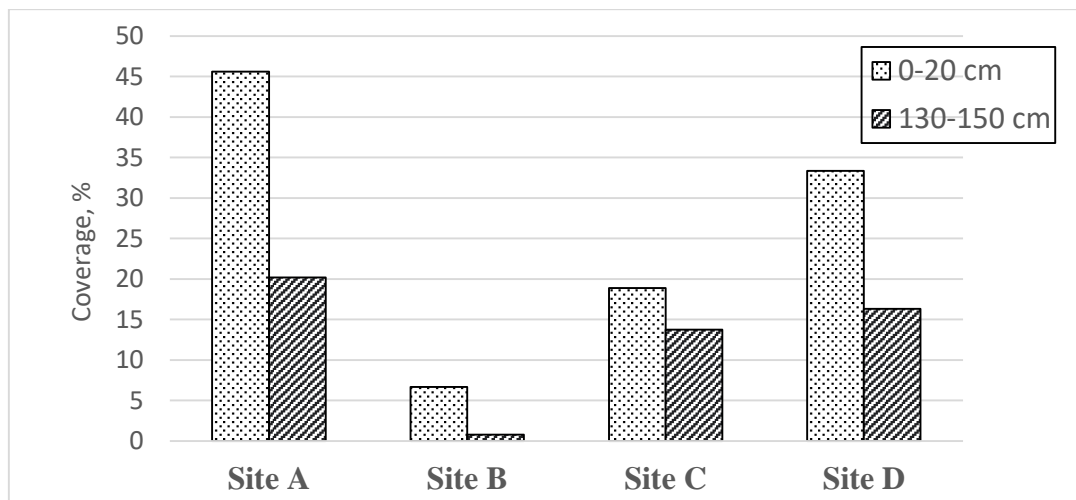


Fig. 4. Total lichen coverage at the selected study sites

#### Lichens as bioindicator of air quality

Sulfur dioxide level in the air can be estimated qualitatively by studying the epiphytic lichens growing on trees (Hawksworth, 1970). In contrary, higher vascular plants and trees respond to air pollution at much slower rate (Muir et al., 1988). We observed lichen diversity within and outside of the city of Ulaanbaatar. All species of the trees and bushes near roads, parks and residential areas of Ulaanbaatar city do not bear any of the species of lichens. This result simply suggests a disastrous amount of air pollution that is mean winter sulfur dioxide concentration is around or exceeded  $170 \mu\text{g}/\text{m}^3$ . This finding also meets measurement results from the air quality monitoring stations. Bogd Khan Mountain area, downwind of the city bear only lichen species tolerant to mild pollution, but size, color and morphology are already changed, and this result indicate plant stress under polluted conditions.

#### CONCLUSION

In this study we observed clear change in lichen diversity downwind and upwind of the capital city Ulaanbaatar. The results suggest that polluted air generated from conventional stoves from ger areas transferred to the southern part of the city and show its negative impact to Bogd Khan Mountain ecosystems. Lichens are the first organisms respond to environmental pollution and warn us; but if

such antropogenic false activity still remains for the future, many other important life forms may degrade in term of prolonged exposure time.

## REFERENCES

- [1] Baljinnyam, N., Gerbish, Sh., Ganbold, G., Lodoysamba, S., Frontasyeva, M., 2009. Heavy metals in the environmental objects of non-ferrous industrial region of Mongolia, the town of Erdenet. The 2nd International Conference on X-Ray Analysis. Conference proceeding p. 185-193
- [2] Davy, P. K., Gunchin, G., & Markwitz, A. (2011). Air Particulate Matter Pollution in Ulaanbaatar, Mongolia: Determination of Composition, Source Contributions and Source Locations. *Atmospheric Pollution Research*, 2, 126-137.
- [3] Das P. Joshi S, Rout J. Upreti DK (2013). Lichen diversity for environmental stress study: application of index of atmospheric purity (IAP) and mapping around a paper mill in Barak Valley, Assam, northeast India. *Trop Ecol.* 54 (3): 355-364.
- [4] Delgermaa S., Enkhtuya O., Munkhjargal B. (2016). Estimation influence of air pollution in Ulaanbaatar city on epiphytic Lichen. International expert consultation on "Understanding and addressing the impact of air pollution on child health in Mongolia". Organized under the auspices of the speaker of the Mongolian Parliament. 25-26 January, Ulaanbaatar.: 163-175.
- [5] Enkhtuya O. (1999). The lichens of Bogd Khan Mountain as Air Pollution monitors of UB City. Abstract Collection Third World Academy of Sciences (TWAS) Symposium on Grassland Ecosystems Management in the Mongolia Plateau, Xilinhote: IMGERS.- 72.
- [6] Enkhtuya, O. (2007). The lichens of Bogd Khan Mountain and air pollution. "Bambie foundation" press, Ulaanbaatar.
- [7] Galsan P., Cogt U., Enkhtuya O. (1995). On the method of the complex study of atmospheric air pollution in Ulaanbaatar city. Proceedings of international conference "Asian ecosystems and their protection", p 110-115.
- [8] Ganbold, G., Gehrbish, Sh., Tshendehekhhuu, Ts., Gundorina, S.F., Frontas'eva, M.V., Ostrovnaya, T.M., Pavlov, S.S. (2005). Atmospheric deposition of trace elements around Ulan Bator city studied by moss and lichen biomonitoring technique and INAA (JINR-E--18-2005-113). Joint Institute for Nuclear Research (JINR)
- [9] Giordani P. (2007). Is the diversity of epiphytic lichens a reliable indicator of air pollution? A case study from Italy. *Environ Pollut.* 146:317-323.
- [10] Hauck, M. (2008). Epiphytic lichens indicate recent increase in air pollution in the Mongolian capital Ulan Bator. *The lichenologist*, Vol.4 (2). Cambridge University Press.
- [11] Hawksworth, D. (1970). Qualitative Scale for estimating Sulphur Dioxide Air Pollution in England and Wales using Epiphytic Lichens. *Nature* 227(5254):145-148
- [12] Muir PS, McCune B. (1988). Lichens, tree growth, and foliar symptoms of air pollution: are the stories consistent? *J Environ Qual.* 17:361-370.
- [13] Myagmartseren, P., Bazarkhand, Ts., Myagmarjav, I., and Munkhnaran, S. (2018). The fractal geometry of urban land use: the case of Ulaanbaatar city, Mongolia. *Land* vol. 7(2), 67.
- [14] Orange A, James PW, White FJ. (2010). *Microchemical methods for the identification of lichens*. 2nd ed. London: British Lichen Society.



## BIG DATA IN WATER SUPPLY AND SEWERAGE SYSTEMS

Stanko P. Stankov<sup>1</sup>

<sup>1</sup>University of Niš, Faculty of Electronic Engineering, Department of Automatic Control,  
Aleksandra Medvedeva 14, 18000 Niš, Serbia

e-mail: [stanko.stankov@elfak.ni.ac.rs](mailto:stanko.stankov@elfak.ni.ac.rs)

**Abstract:** Digitization in the field of water supply and sewerage is associated with the concept of processing extremely large amounts of data (big data) and processing and analysis of these data (data mining). In essence, the significance of the mentioned data for water supply and sewerage systems is huge, but in order to understand their role, it is necessary to assess the possibility of using and applying these data. In conditions in which data from various sensors and equipment in the field of kai and data related to customer needs are permanently obtained, the amount of this data increases significantly. Replacing classic water meters with smart ones also significantly increases the amount of information. New trends in the management and supervision of water supply and sewerage systems enable operators to make maximum use of this data, and management to undertake activities at the tactical and strategic level. Modern SCADA (Supervisory Control and Data Acquisition) systems significantly contribute to the rapid detection of infrastructure failures, reduction of losses by detecting leaks, overflows in tanks. Based on the collected data, operational efficiency is improved, opportunities for proactive maintenance of water and sewage resources are identified, as well as preparation for long-term investments.

**Key words:** data, acquisition, control strategy, supervision

### INTRODUCTION

Information related to the needs of clients in the water supply and sewerage sector is one of the most important data, which can be used to predict the required amount of water for a certain part of the water supply area in order to achieve optimal efficient network control. In the individual sense, the data can indicate whether there is a leaking in a particular client [1]. The information acquisition from the water meter can be used to detect zones in which e.g. pressure control and in which unusually high consumption occurs. The data can also be used for the implementation of complex algorithms that calculate in which regions the lowest revenues are achieved during the exploitation of water by customers [1], [2].

The data obtained, especially from smart water meters, can be useful in many ways. This data is collected for a month or more and is mainly used to bill users. By increasing the frequency of collecting this data via smart water meters, the amount of this information increases by an order of magnitude. The temporal character of the data is extremely important, since medium-term information is vital for the daily activities of the water supply system, and long-term data play a role in creating a control strategy [3].

The analysis of operational data in the field of water supply and sewerage leads to the knowledge of current situations. This data has great potential for the big data sector. Knowledge of the situation is crucial for operators in management and control centers and for maintenance services to respond in a timely manner. Operational data enables the identification of risks related to a specific consumer or a specific zone in which efficiency is relatively low, while process optimization would lead to savings for both the company and the client. Operational data is usually used on a daily basis or within a week. In the long run, data on parameters and process values can be indicators of the periodicity of maintenance of specific equipment and indicate the need for investment in order to improve the existing infrastructure [4], [5].

### SUPERVISION AND EFFICIENCY

In companies whose activity is the development, construction and maintenance of water supply and sewerage systems, there are a large number of sensors and automation elements in the field that send

large amounts of data to supervisory control centers with a high frequency. These data are of interest for the functionality of water supply and sewerage systems, and data analysis provides an opportunity to optimize operation, preventive, current and investment maintenance of the systems themselves, correction of management algorithms to increase efficiency and reduce operating costs. Operators in the management system can e.g. to reduce the dosing of activated carbon in wastewater treatment plants, precisely by analyzing the large amount of data coming from the sensors in the filter fields [6]. Due to the fact that the activated granular coal changes in a timely manner, the concentration of trihalomethane is maintained in the allowed range. Further improved efficiency can extend equipment life. With the help of quality data, you can e.g. in wastewater treatment plants, reduce the dosage of chemicals and maintain the essential parameters of the treated water (e.g. pH value). In this way, reducing the amount of chemicals can limit or delay the deterioration of the most important equipment of these plants [7].

## **PREDICTIVE ANALYSIS OF DATA**

Water and sewage systems can have a significant benefit from the large amount of data generated by various equipment, especially when creating predictive models that lead to more precise and detailed results. The application of big data in water and sewage systems is reflected in the preparation of predictive maintenance strategies [7]. IoT sensors, which are an integral part of the equipment, provide information on key parameters such as temperature, vibration, speed, level, etc. Algorithms for big data analysis find a correlation that allows a fault prediction to be made very quickly for a particular device operating in a mode outside the nominal range. Predictive maintenance strategy can increase the service life of equipment and increase the efficiency of maintenance programs, which allows to avoid costly delays by timely signaling the potential failure of a particular device. Some modern supervisory control systems can turn off a certain device, which is on the edge of failure, with the appropriate message, light and sound signaling [8]. Big data can combine inside information with information from third-party sources to improve the quality of the predictive model. It is possible e.g. combine data from multiple wastewater treatment plants, which allows for thorough analysis to detect trends and forecast inletflow balances and enables operators to take appropriate action. Improved procedures for the acquisition, processing and use of large amounts of data can be of great importance for companies whose activities are water supply and sewerage. Wastewater treatment plants in this sector often have problems with depreciation and equipment that is difficult to maintain due to extreme operating conditions and inaccessibility [9].

Precisely on the basis of big data, it is possible to act preventively and perform the necessary interventions in a timely manner, which preserves the equipment and avoids costly delays. Water supply and sewerage systems began to use the benefits of big data relatively late, which increases the reliability and optimization of services provided to customers. Some of the big data solutions available on the market enable integration with sensor and communication technologies, modeling procedures and SCADA systems. With the accelerated application of advanced computer systems, cheap sensors that measure various process quantities and parameters, data is collected and sent to control devices. Cost-effective data warehousing systems and water companies can get much more real-time information at reduced costs, and in some cases, data from hitherto unavailable zones [10]. Smart technologies such as big data allow operators to optimize customer service. According to the analyzes, despite the fact that the road is relatively long, the water supply and sewerage sector has taken the right direction in its further development. However, in order to fully justify investments in smart technologies, it is necessary to have a clear idea and vision of organizational and strategic goals, while implementing and adapting business plans.

The main task and ultimate goal of the system for data collection, processing and analysis in companies dealing with water supply and sewerage problems is to provide quality services in the field of information, which facilitates the work of operators and helps managers develop new opportunities for cost monitoring and risk management improving all service levels [11 - 13]. Implementation of intelligent systems so-called AMI (Advanced metering infrastructure) in the field of water supply and sewerage is growing. Smart grid solutions are widely represented in electricity distribution companies, and they are also finding their way into the water supply sector, so that today we can talk about intelligent networks in water supply [14].

## **SMART TECHNOLOGIES**

Smart technologies are aimed at solving key challenges in the water supply and sewerage sector, such as water and energy losses, lack of water resources on a global level, management of current and operating costs, etc. There is already a wide range of reliable intelligent devices on the market, such as AMR (automatic meter reading) and complete solutions that can be applied in solving problems related to water supply and sewerage. This is also the case with the more recent AMI technology, which is increasingly available in financial terms [14].

## **AMI INFRASTRUCTURE**

AMI infrastructure is an automated two-way communication between a measuring device (e.g. a water meter) with an IP address and a water supply company. The basic idea for the application of AMI applications in utility systems is to obtain basic real-time data on water needs, status and energy consumption of installed equipment in the water supply and sewerage system, based on which forecasts can be made about accidents, downtime, losses in system, etc. [14]. Both water supply systems and customers benefit from the introduction of intelligent technologies. The key is in the data that AMI systems operate with. Possibilities for monitoring and analyzing the behavior of water supply networks and equipment, as well as identifying various problems justify serious investments in the construction of intelligent water infrastructure. In the future, data from intelligent measuring devices and sensors will be increasingly used in the water sector not only in solving operational tasks such as registration, localization and troubleshooting (leaks, failures, etc.) but also in strategic goals such as reducing operating costs, predictive maintenance of devices and equipment, improving the quality of services, efficient forecasting of infrastructure investments, etc. [15].

## **AMI PLATFORMS IN FUNCTION OF INCREASING THE EFFICIENCY OF WATER SUPPLY SYSTEMS**

Thanks to AMI systems, the need for manpower is reduced, data acquisition related to users and account generation is fully automated and remote. Based on the data collected from smart water meters, the processes of water storage, transport and distribution, timely detection of water leaks and reduction of losses can be improved. Two-way communication enables better provision of services to users through precise and adequate calculation of consumption, as well as efficient preventive, current and investment maintenance of resources. The systems for segmentation and analysis of customer bases that are the basis of modern AMI platforms can help identify the needs and requirements of customers of water companies, as well as activate various programs that will reduce losses in water supply [14]. Based on these capabilities, water utility companies can achieve various goals related to efficient management, optimization of equipment operation, planning, forecasting and proactive control of capital investments.

## **WATER SUPPLY SUPERVISION**

Nowadays, the application of supervision and control of water supply is increasing, in urban and rural areas, where individual users and industrial consumers have an insight into water consumption. Because water resources are limited, there are two main objectives of monitoring: reducing water losses and rationally control of needs [6], [7]. Although various strategies and programs are applied in the world to reduce water losses, primarily through the use of modern supervisory control systems, water losses due to irrational use and leaks in various places are a very serious problem in the water supply system. The European Environment Agency gives a forecast until 2030. that the need for vision, on a global scale, will increase by as much as 40 % [8], [9].

## **SENSORS IN FUNCTION OF EFFORTS TO REDUCE WATER LOSSES**

With the technological development of sensors and with the reduction of their price, they become an integral part of supervisory control systems in water management. Wireless sensor networks can be

implemented both independently and as part of complex platforms for water resources control in individual, commercial - business and industrial facilities [6], [7]. Modern supervisory control systems used in plumbing systems are connected to flow sensors usually in the range of 0.15 to 60 L/min. The sensors send data to the center, which activates an automatic alarm, if the flow has certain values higher than the set threshold. This allows operators to register local leaks and undertake appropriate overhaul activities on the water supply network to combat water loss. According to Libelium, a Spanish supplier of sensor technology and IoT applications, the use of sensor technology in water management in Japan saves \$ 170 million annually [16]. In the floors of individual buildings, shopping and business centers and in various industrial facilities, sensors are installed that can register the existence of leaks in water pipes. In open water supply networks, soil moisture sensors installed at an appropriate distance from each other can signal a drastic increase in soil moisture, which is a warning of possible water leakage and a signal to optimize irrigation. Strategic deployment of sensors in the entire area of water supply provides sufficient data necessary for the functionality of the supervisory control system. The data is sent wirelessly and at certain intervals to the control center where it is processed and analyzed. They can also be applauded on a cloud server or over the Internet where they are publicly available to citizens or industry.

### **WATER SUPPLY SYSTEM – EXAMPLE**

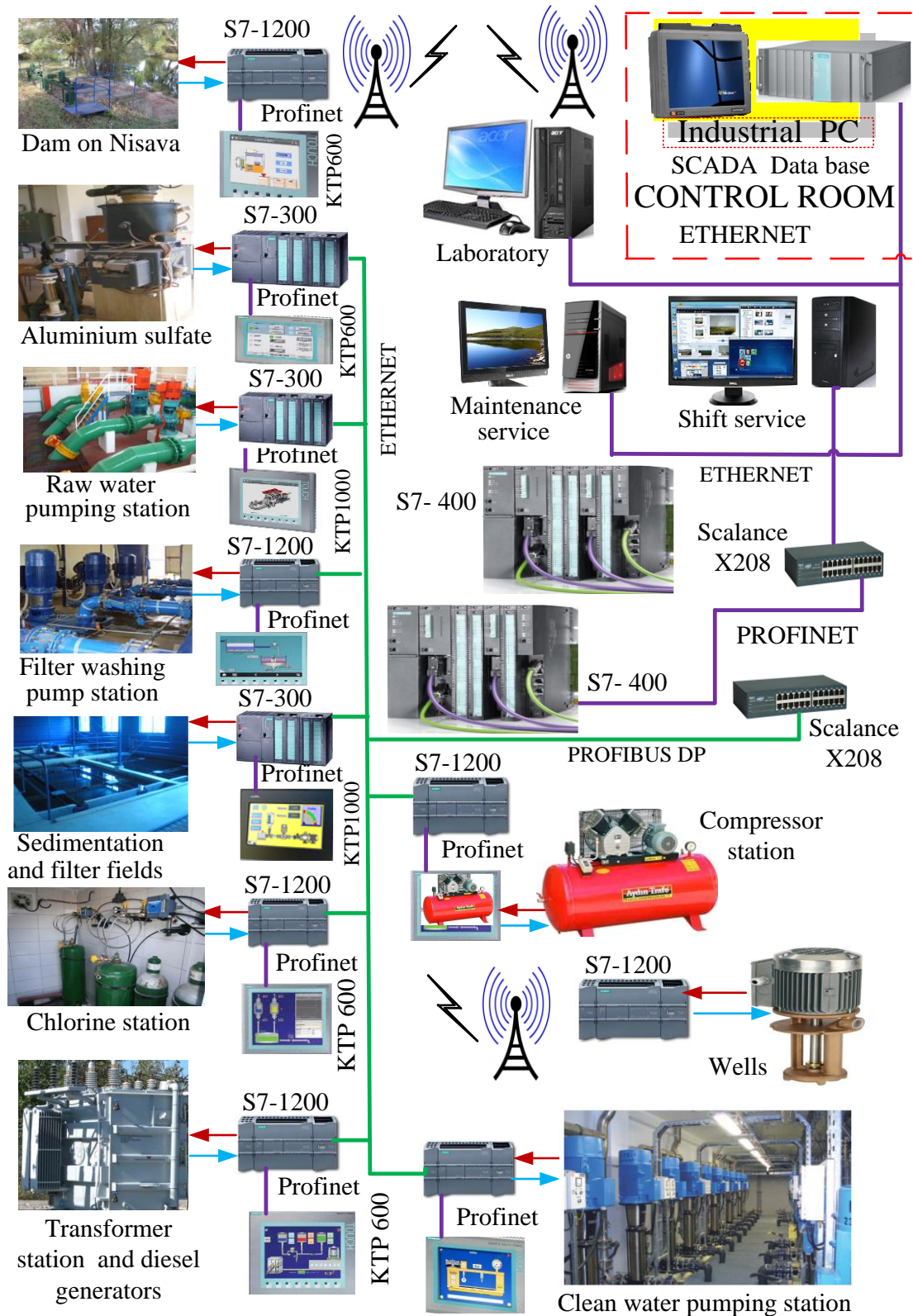
An example of a complex water supply system, which consists of a number of technical - technological units is the water factory Mediana 2 in Nis. The supervisory control system is based on programmable logic controllers and operator panels, which are interfaces between the operator and the plant. The control system is also connected to the SCADA computer in the control room (CR). Nominal factory mode is automatic. For special purposes, individual technical units can be switched to manual control mode, which is suitable for testing equipment during overhauls and maintenance. The block diagram of the factory management is shown in Fig.1.

A large amount of data is generated, acquisition and processed here [6], [7]. Basically, the control of the Mediana 2 water supply system is a central supervisory control system installed in CR. The system architecture is based on a master-slave configuration consisting of PLC controllers: the master PLC is Simatic S7-400 (redundant pair); S7-300 (Al sulfate preparation and dosing plant, PS of raw water, sedimentation and filter fields, PS for washing of filter plant, clean water pump station); S7 1200 (transformer station, diesel generator, dam, system for mechanical water purification - mechanical rakes and sieves; compressor station, chlorine station) [6], [7].

Each local controller is connected to the operator panel KTP communication protocol PROFINET. The connection of the master controller to the slave controllers and servers was done via the ETHERNET network. A real-time database server has been installed in CR, which distributes data to workstations - clients (CR, maintenance service, chemical laboratory, management) [6], [7]. SCADA is organized in the form of menus and submenus, showing the functionality of the system with certain animations (e. g. operation of pumps, electromotor valves), the change of a quantity in real time in the form of a trend graph or in digital form (level values, flow, turbidity, residual chlorine, etc.), reaching the limit values is signaled as an alarm message with sound and light signaling. The main tasks set before the SCADA system are:

- acquisition of real-time digital and analog data from all objects connected to the system (a large number of tags);
- archiving relevant information obtained on the basis of collected data in a relational database;
- presentation of real-time and archived data via synoptic screens, trends, charts and tables;
- real-time control and supervision of water intake, mechanical water purification, chemical preparation, well plants, pumping stations.

The master redundant tandem system of PLCs S7-400 in conjunction with a SCADA computer in CR dictates communication with all remote stations, sends queries, commands and accepts and archives all messages arriving from controlled objects [6 - 9].



**Fig. 1.** Block diagram of supervisory control of Mediana 2 water supply system

### DISPLAY OF FILTER WASHING PUMP STATION

Figure 2 shows one SCADA screen of a pump station (PS) for washing filters. It is one of a number of technical units of the Mediana 2 water supply system. Within this PS there are 3 pump units whose

power is 75 kW - two working pumps and one spare which, if necessary, works in alternation with the main pump [6], [7]. The pumps are powered via frequency inverters. Each inverter at the input has semiconductor fuses and compact switches with the possibility of remote shutdown in case of failure or blockage of a particular pump. The control of the PS for filter washing is from the PLC system which, based on the obtained sequence and the state of openness/closure of individual valves in the filter fields, includes and gives permission for switching on the drive of a certain pump. Pumps provide a set flow value in the discharge line to the filter fields. A flow meter (Fp) is installed on the pressure pipeline. The maximum set flow is 125 L/s. The flow rate information (analog signal 4-20 mA) is input to the analog input of the PLC from where, according to the number of active pumps and the selected operating mode, the reference flow values for each of the pump units are transmitted as analog values to the inputs of frequency inverters.

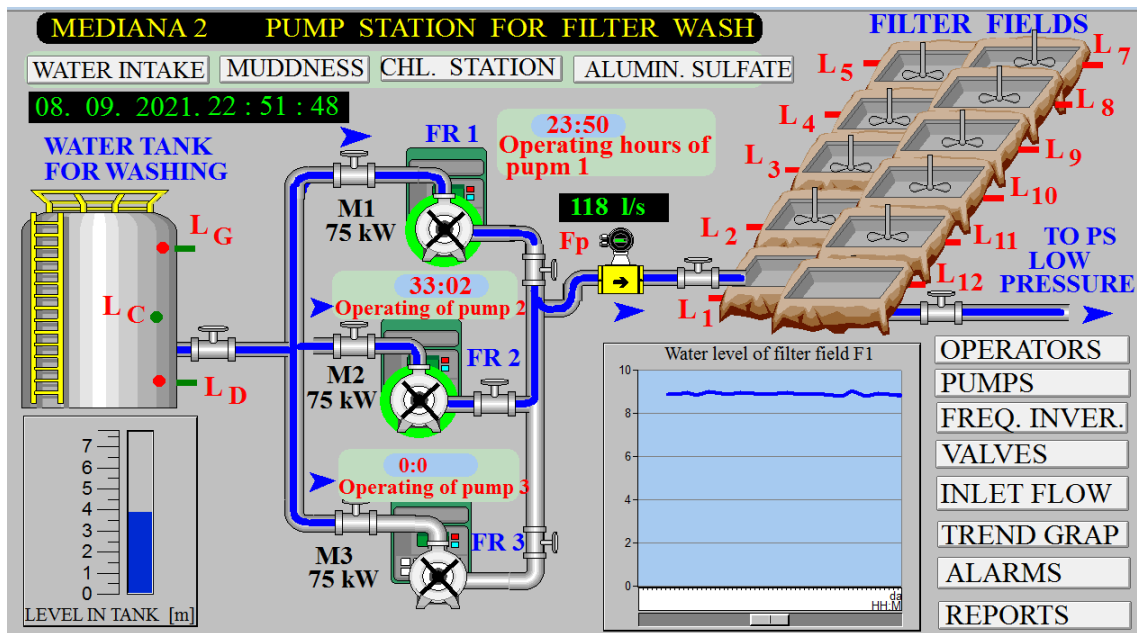


Fig. 2. SCADA screen in CR of water pump station, for filters washing

Protection against dry running of PS pump units is via built-in hydrostatic probes for continuous level measurement. Control of the operation of the PS for filter washing and regulation of the flow of washing water in the discharge line was realized using the Siemens S7-1200 PLC [6 - 9].

## CONCLUSION

It is obvious that an extremely large amount of data is generated in water supply and sewage systems. The paper describes the control - monitoring system based on PLC and SCADA configuration with decentralized distributed control of technological units, which are integral parts of the water factory. The control units perform program control of the plants and regulation of technological quantities and parameters such as levels, flow, speed, pressure, pH value, turbidity, dosing of aluminum sulfate, chlorine, etc. Various situations in the work of installed machines and devices are considered and they are protected from technological and electrical accidents. Graphical display of components using dynamic screens allows the operator to monitor the process. The transformer station and diesel generator, dam, mechanical water purification process, preparation and dosing of aluminum sulfate, chlorine dosing, processes in filter fields, sedimentation tanks, raw water pumping stations, filter washing water and clean water are controlled. The control system identifies changes in the state of the process, diagnoses and evaluates errors, enables prediction of the behavior of control objects in the conditions of changing input variables and generates optimal values of control signals in order to achieve the prescribed water quality. In addition, the system performs the acquisition, processing and archiving of data related to the values of process quantities and the state of the installed equipment. It is possible to create and print shift and periodic reports on the functionality and availability of

individual technological units and the course of production, based on which analyzes and necessary corrections are made in order to increase efficiency. Alarm states that occur in case of failures or exceeding the set values of certain quantities are also monitored. The proposed supervisory control system enables:

- periodic reading of characteristic sizes and working hours of devices and equipment,
- archiving of changes on all digital and analog inputs and outputs of control units,
- long-term archiving of all actions of the operator,
- assigning flexible work schedules.

Visualization of controledobjects with graphical and tabular display of relevant physical values and parameters is of great importance for the maintenance sector. On the SCADA system screen, through dozens of intuitive screens, there is an insight into the functionality of the water factory, and the appearance of alarm signals enables faster localization of faults, which significantly increases the efficiency of maintenance. Light and sound signaling of reaching critical values (alarms) is enabled, during which appropriate control logic activities take place.

## REFERENCES

- [1] Buyya, R., Calheiros, N. R., Dastjerdi, V., A.: Big Data Principles and Paradigms, The University of Melbourne, Australia Elsevier 2016.
- [2] Shaw, A.: Understanding Big Data In The Water Industry, March 20, 2017.
- [3] Han, J., Kamber, M., Pei, J.: Data Mining: Concepts and Techniques, A volume in The Morgan Kaufmann Series in Data Management Systems, Book, Third Edition, 2012.
- [4] Syromyatnikov, D. A., Pyatkina, D. A., Kondarenko, L. N., Krivolapov, S. I., Stepanova, D. I.: Big data analysis for studying water supply and sanitation coverage in cities (Russia), Revista ESPACIOS,. Vol. 40 (N° 27), Year 2019.
- [5] Witten, H. I., Eibe Frank, E., Hall, A. M., Book Data Mining: Practical Machine Learning Tools and Techniques, A volume in The Morgan Kaufmann Series in Data Management Systems, 2011.
- [6] Stankov, S.: Sistem nadzora i upravljanja postrojenjem za prečišćavanje vode, časopis „Vodoprivreda”, broj 4-6, vol. 50, str. 319 - 332, Beograd, 2018.
- [7] Stankov, S.: Glavni projekat rekonstrukcije elektroenergetskog napajanja i upravljanja Fabrikom vode „Mediana 2“, Elektronski fakultet, Niš, 2013.
- [8] Stankov, S., Mitić, D., Jovanović, Z.: Upravljanje baždarnicom za industrijske vodomere pomoću PLC i SCADA sistema, Zbornik radova 10 međunarodne konferencije Vodovodni i kanalizacioni sistemi, Jahorina, 2010., Bosna i Hercegovina, (str. 125 - 134), maj 2010.
- [9] Stankov, S.: Control of Pumping Stations in Water Supplay Systems”, journal „Voda i sanitarna tehnika”, Year XLI, No. 3-4, June–September 2011, (pp. 47 - 54), Belgrade, 2011.
- [10] Stankov, S.: Sistem za baždarenje industrijskih vodomera – modeliranje i analiza stabilnosti, časopis „Bakar”, vol. 41, No. 2 (str. 41 - 58), Bor, 2016.
- [11] Stankov, S., Antić, D., Petronijević, M., Arsić, S.: Control and Monitoring System of the Mineral Wool Packaging, journal Annals of Faculty Engineering Hunedoara – International Journal of Engineering, Volume XV, fascicule 2, (pp. 43 - 46), May 2017.
- [12] Stankov, S., Mitić, D., Ičić, Z.: Supervisory and Control of HVAC Systems, journal „Facta Universitatis”, Series: Automatic control and Robotics, vol. 9, No 1 (pp 151 - 160), 2010.
- [13] Stankov, S.: Prenos podataka u sistemima za nadzor i upravljanje toplotnim postrojenjima, 41 međunarod. kongres KGH, Zbornik radova, (str. 269 - 279), Beograd, 1 - 3. decembar 2010.
- [14] Advanced Metering Infrastructure: Drivers and Benefits in the Water Industry <https://www.waterworld.com/technologies/amr-ami/article/16192432/advanced-metering-infrastructure-drivers-and-benefits-in-the-water-industry>
- [15] Smart meters and advanced metering infrastructure

- <https://www.dnv.com/services/smart-meters-and-advanced-metering-infrastructure-6831>  
[16] Organization Libelium  
<https://www.crunchbase.com/organization/libelium/technology>



## PHENOLIC PROFILE DETERMINATION OF FRUŠKA GORA POMACES FOR UTILIZATION PURPOSES

Diandra Pintać<sup>1</sup>, Ljilja Torović<sup>1</sup>, Dejan Orčić<sup>2</sup>, Dejana Bajić<sup>1</sup>, Branko Markoski<sup>3</sup>, Neda Mimica-Dukić<sup>2</sup>, Marija Lesjak<sup>2</sup>

<sup>1</sup>University of Novi Sad, Faculty of Medicine, Novi Sad, Serbia

<sup>2</sup>University of Novi Sad, Faculty of Sciences, Novi Sad, Serbia;

<sup>3</sup>University of Novi Sad, Technical Faculty "Mihajlo Pupin", Zrenjanin, Serbia

e-mail: [diandra.pintac@mf.uns.ac.rs](mailto:diandra.pintac@mf.uns.ac.rs)

**Abstract:** Pomace is a by-product of wine industry that is rich in bioactive compounds. However, due to ample amounts that are generated annually, its disposal has become a serious environmental problem and the waste management needs to be more efficient. This paper investigates the phenolic composition of pomace from five different grape varieties, originating from Fruška Gora wine region, in order to evaluate its utilization potential. For that purpose, 47 phenolics and 3 triterpenoids were analyzed by LC–MS/MS and 5 anthocyanin glucosides by LC–UV–vis, in 2 international (Chardonnay, Muscat Hamburg), 1 autochthonous (Frankovka) and 2 domestic (Sila, Župljanka) grape varieties. A total of 33 compounds were detected in the samples and Muscat Hamburg pomace stood out with higher quantities of most of the analyzed phenolics, while Frankovka contained larger amounts of anthocyanins and ursolic acid, known for its anticancer properties. This study showed that Fruška Gora pomaces have a high potential for utilization in different industries and supports their further exploitation.

**Key words:** pomace, Fruška Gora, autochthonous and domestic grape varieties, polyphenols, ursolic acid

### INTRODUCTION

Thanks to its health benefits and hedonistic value, wine is one of the most popular alcoholic drinks in the world. An increase in wine consumption among consumers is evident each year and this represents a major driving force for the expansion of wine industry. With this increase, apart from wine, large quantities of by-products in the form of pomace are being generated during winemaking. It is estimated that annually up to 9 million tons of grape pomace remain and its disposal poses a serious environmental and economic problem [1]. Since the pomace consists of pressed grape leftovers such as skins, seeds and stems and since only a part of phytochemicals is transferred from grape to wine during maceration and fermentation, a lot of bioactive compounds remain in the pomace. Most of the phytochemicals that remain belong to the polyphenolic group which is best known for its antioxidant properties, as well as cardio- and neuroprotective, anti-inflammatory, antiageing and anticancer potential. The grape variety, agroclimatic factors and winemaking practices mostly influence the chemical composition of pomace, which is why it is important to determine the presence and quantity of beneficial compounds in order to extract and exploit them further[2,3].

The aim of this research was to investigate the chemical composition of five different pomaces of international (Chardonnay and Muscat Hamburg), autochthonous (Frankovka) and domestic (Sila, Župljanka) grape varieties originating from Fruška Gora vineyards, in order to evaluate their utilization potential for a further application in food, pharmaceutical and cosmetic industries. A previous study regarding polyphenolic extraction from pomaces by Pintać et al. (2018) defined ethyl acetate (EtOAc) as the best solvent for obtaining an extract rich in polyphenols, and that is why it was the solvent of choice in this study as well. The chemical composition was determined by analyzing 47 phenolic compounds and 3 terpenoids with the LC–MS/MS and 5 anthocyanin glucosides by LC–UV–vis method, and a comparison of pomaces from different varieties was made.

### MATERIAL AND METHODS

#### Extract preparation

Grape pomaces were generously donated by wineries located in Fruška Gora winery region in October 2014, namely Agner (Župljanka), Bajilo (Muscat Hamburg, Sila), Došen (Chardonnay) and Vinum

(Frankovka). Pomaces were collected after being separated from juice in the wineries, and 1 g of each pomace was extracted with 10 mL of EtOAc, three times for 6 h, at room temperature with moderate shaking. After the extraction, fractions were merged, filtered and the solvent was evaporated to dryness under vacuum at 45 °C and dissolved in warm distilled water. The extracts were washed repeatedly with petroleum ether (fraction 40–60 °C) till full decolorization of the petroleum ether fraction occurred, to remove the nonpolar compounds. The extracts were dried under vacuum, and dissolved in DMSO (w/v) to obtain stock solutions (20 mg/mL).

#### **Quantitative LC–MS/MS analysis**

All extracts were dissolved in 50% methanol to the final concentration of 2 mg/mL. Determination of the selected phenolic and triterpenoid compounds was done using Agilent Technologies 1200 Series high-performance liquid chromatograph coupled with Agilent Technologies 6410A Triple Quad tandem mass spectrometer with electrospray ion source, by the previously published procedures [4,5].

#### **Quantitative LC-UV–vis analysis**

All extracts were dissolved in 50% methanol to the final concentration of 2 mg/mL. Determination of five selected anthocyanins, commonly found in grapes (delphinidin-3-O-glucoside, malvidin-3-O-glucoside, cyanidin-3-O-glucoside, petunidin-3-O-glucoside, peonidin-3-O-glucoside), was carried out using Agilent 1100 series liquid chromatograph (USA), consisting of quaternary gradient pump, autosampler with injection system (10–200 µL), column heater, UV–vis detector and software package, as described previously [6,7]. in OIV (2013) and Cvejić et al. (2016).

### **RESULTS AND DISCUSSION**

From 55 analyzed compounds, divided into 11 classes (phenolic acids, flavonols, flavan-3-ols, flavones, isoflavones, flavanones, anthocyanins, stilbenes, coumarins, lignans and triterpenoids), 33 were found in Fruška Gora pomaces, as shown in Table 1. Pomace extracts were rich in catechin and epicatechin, gallic and ellagic acids, kaempferol 3-O-glucoside, quercetin and hyperoside. Highest concentration of 16 compounds was detected in Muscat Hamburg pomace, mostly from the phenolic acid, flavone, flavan-3-ol, flavanone and stilbene classes, and since this variety is widely used for making rose wines, where there is a shorter maceration time of pomace with juice, it is logical that a lot of compounds remain in the pomace. Chardonnay pomace contained most of the analyzed flavonols in higher concentrations. While flavonols were more abundant in white pomaces, anthocyanins, that could be used as natural food colorants, were only present in the red pomace of Frankovka variety. Ursolic acid was detected in all pomaces, but autochthonous variety Frankovka and domestic variety Sila represented the richest source of this bioactive compound, that is gaining attention due to its many pharmacological properties such as anticancer, hepatoprotective, gastroprotective and immunomodulatory activities[8]. All of the detected compounds are known for their positive effects on human health and pomaces proved to be a rich and inexpensive source. Thus, their utilization would be beneficial for different industries, such as food, pharmaceutical and cosmetic industries. Not only for industries, but for economy and environmental protection as well. because managing such an enormous amount of waste, that is produced annually, needs to be more effective.

**Table 1.** Content of quantified\* polyphenolic and triterpenoid compounds in EtOAC pomace extracts [ng/mg d.e.]

<b>phenolic acids</b>	<b>Muscat Hamburg</b>	<b>Frankovka</b>	<b>Župljanka</b>	<b>Sila</b>	<b>Chardonnay</b>
<i>p</i> -hydroxybenzoic acid	65.32	54.79	28.00	16.39	50.79
protocatechuic acid	72.69	15.24	19.60	16.98	24.85
vanillic acid	1119	553.7	< LoQ	< LoQ	< LoQ
gallic acid	3109	2081	1056	1589	550.2
ellagic acid	3030	< LoQ	1161	2715	913.7
syringic acid	296.0	1145	< LoQ	20.85	17.63
<i>p</i> -coumaric acid	16.23	9.735	38.07	16.52	13.97
caffeic acid	88.07	< LoQ	92.89	72.58	83.31
ferulic acids	246.6	31.32	< LoQ	35.37	32.05
<b>flavonols</b>					
quercetin	1203	841.1	734.8	1439	1249
quercetin 3- <i>O</i> -glucoside	1148	1619	7589	6742	13527
hyperoside	296.4	380.7	1292	1397	2361
isorhamnetin	786.0	745.7	533.5	570.5	573.4
quercitrin	133.2	8.697	242.3	525.4	663.3
rutin	14.87	18.76	397.3	185.3	136.6
kaempferol	650.0	584.3	512.2	1027	940.0
kaempferol 3- <i>O</i> -glucoside	191.9	612.9	2437	2981	4772
morin	23.35	10.55	4.089	< LoQ	< LoQ
<b>flavan-3-ols</b>					
catechin	11633	6461	13414	1170	2477
epicatechin	5907	5697	5670	952	2073
<b>flavones</b>					
apigenin	5.596	< LoQ	1.972	0.932	1.080
luteolin	55.39	< LoQ	< LoQ	34.19	34.64
luteolin 7- <i>O</i> -glucoside	48.72	35.08	42.99	44.19	51.17
baicalein	3.712	1.893	1.659	1.342	1.609
chrysoeriol	5.060	1.677	2.690	1.849	2.777
amentoflavone	94.41	59.16	44.07	21.12	25.24
apiin	1.777	< LoQ	< LoQ	< LoQ	2.272
<b>flavanones</b>					
naringenin	175.8	7.203	40.69	21.95	15.92
<b>coumarins</b>					
esculetin	35.00	19.93	40.73	28.32	26.42
<b>stilbenes</b>					
resveratrol	342.0	53.25	303.3	55.29	113.2
<b>anthocyanins</b>					
peonidin 3- <i>O</i> -glucoside	< LoQ	26.25	< LoQ	< LoQ	< LoQ
malvidin 3- <i>O</i> -glucoside	< LoQ	81.25	< LoQ	< LoQ	< LoQ
<b>triterpenoids</b>					
ursolic acid	1465	3069	2243	2900	1427

\*Analyzed but not detected: 2,5-dihydroxybenzoic acid, cinnamic, *o*-coumaric, 3,4-dimethoxycinnamic, sinapic acids, umbelliferone, scopoletin, glycyrrhetic acid, glycyrrhizin, vitexin, baicalin, daidzein, genistein, apigenin 7-*O*-glucoside, myricetin, epigallocatechin gallate, matairesinol, secoisolariciresinol, delphinidin 3-*O*-glucoside, cyanidin 3-*O*-glucoside, petunidin 3-*O*-glucoside; d.e. – dry extract

## CONCLUSION

In this research paper, grape pomace originating from varieties grown in Fruška Gora proved to be a rich source of bioactive compounds belonging to polyphenolic and triterpenoid classes. In total, 55 compounds were analyzed, of which 33 were detected and quantified. Apart from providing detailed information on the chemical composition of pomaces from this famous wine region, this research also pointed out which beneficial compounds are most abundant in different varieties. This is very important for utilization purposes, as different industries have different needs and will choose an appropriate variety that contains more compounds that can be used as dietary supplements, natural food colorants, preservatives or pharmaceuticals. Better waste management and further implementation of pomace extracts in industry is highly supported in this study.

## REFERENCES

- [1] Jara-Palacios, M.J., Hernanz, D., Cifuentes-Gomez, T., Escudero-Gilete, M.L., Heredia, F.J., Spencer, J.P.E., Assessment of white grape pomace from winemaking as source of bioactive compounds, and its antiproliferative activity, *Food Chemistry*, Vol.183, pp. 78-82, 2015.
- [2] Lachman, J., Hejtmánková, A., Hejtmánková, K., Horníčková, Š., Pivec, V., Skala, O., Dědina, M., Příbyl, J., Towards complex utilisation of winemaking residues: characterisation of grape seeds by total phenols, tocals and essential elements content as a by-product of winemaking, *Industrial Crops and Products*, Vol.49, pp. 445-453, 2013.
- [3] Rodríguez Montealegre, R., Romero Peces, R., Chacón Vozmediano, J.L., Martínez Gascueña, J., García Romero, E., Phenolic compounds in skins and seeds of ten grape *Vitis vinifera* varieties grown in a warm climate, *Journal of Food Composition and Analysis*, Vol.19, pp. 687-693, 2006.
- [4] Orčić, D., Francišković, M., Bekvalac, K., Svirčev, E., Beara, I., Lesjak, M., Mimica-Dukić, N., Quantitative determination of plant phenolics in *Urtica dioica* extracts by high-performance liquid chromatography coupled with tandem mass spectrometric detection, *Food Chemistry*, Vol.143, pp. 48-53, 2014.
- [5] Pintać, D., Majkić, T., Torović, L., Orčić, D., Beara, I., Simin, N., Mimica-Dukić, N., Lesjak, M., Solvent selection for efficient extraction of bioactive compounds from grape pomace, *Industrial Crops and Products*, Vol.111, pp. 379-390, 2018.
- [6] Cvejić, J., Puškaš, V., Miljić, U., Torović Lj Rakić, D., Varietal phenolic composition of Probus, Rumenika and Frankovka red wines from Fruška Gora (Serbia) and changes in main compounds during maceration, *European Food Research and Technology*, Vol.242, pp. 1319-1329, 2016.
- [7] OIV, Compendium of International Methods of Wine and Must Analysis. Office International del la Vigne et du Vin, Paris, 2013.
- [8] Woźniak, L., Skąpska, S., Marszałek, K., Ursolic acid-A pentacyclic triterpenoid with a wide spectrum of pharmacological activities, *Molecules*, Vol.20, pp. 20614-20641, 2015.

## STATISTICAL ANALYSIS OF DATA OBTAINED BY MEASURING AIR QUALITY AT CHILDREN'S PLAYGROUNDS IN NOVI SAD

Nebojša M. Ralević<sup>1\*</sup>, Jelena S. Kiurski<sup>2</sup>, Ladin Gostimirović<sup>3</sup>, Aleksandra Mihailović<sup>1</sup>

<sup>1</sup>University of Novi Sad, Faculty of Technical Sciences, Novi Sad, Serbia

<sup>2</sup>University Business Academy in Novi Sad, Faculty of Economics and Engineering  
Management, Novi Sad, Serbia

<sup>3</sup>Visoka poslovno tehnička škola, Doboj, Bosnia and Herzegovina, Republic of Srpska  
e-mail: [nralevic@uns.ac.rs](mailto:nralevic@uns.ac.rs)

**Abstract:** The concern for people's health, especially the health of children in urban areas, is reflected in the control of emissions of carbon dioxide, volatile organic compounds and particles in places where they spend a lot of time. The pollution of CO<sub>2</sub>, VOCs and particulate pollution are indicators of air quality and the aim of this research is to identify them in urban children's playgrounds near the Novi Sad city centre. The measurements of pollutant concentrations as well as temperature and relative humidity were performed on three playgrounds. The data obtained by these measurements were treated with MANOVA and ANOVA statistical techniques. The findings indicate that air quality varies greatly depending on the factors studied and largely depends on the time of day when the measurements were made. Due to the increase in temperature during the day, a significant increase in the concentration of pollutants was observed in the second and third time intervals.

**Key words:** Air quality indicators, MANOVA, ANOVA statistical techniques

### INTRODUCTION

Air pollution is the presence of one or more of outdoor pollutants over time sufficient to endanger human health, and the general quality of the environment. Industrial developments as well as population growth in urban areas have among other things led to air pollution. Thus, e.g. an the increased concentration of carbon dioxide (CO<sub>2</sub>) in the air implied an increased interest in the negative impact of global warming. Scientific research shows increased levels of CO<sub>2</sub> concentration, between 373 and 590 pp, [1] in many cities in case studies on weather effects of complex relationships resulting from emissions, chemical atmosphere and meteorological conditions. Carbon dioxide in urban areas is associated with the burning of fossil fuels. The high level of PM<sub>2.5</sub> especially occurs during the winter cold. Studies conducted in Asia and Europe have shown that the mass concentrations of PM<sub>2.5</sub> and PM<sub>10</sub> particles in classrooms often exceed the guidelines of the World Health Organization (WHO) [1]. Children up to the age of 7 spend a large part of the day on the playgrounds, even when the daily traffic pollution reaches its peak. Many children's playgrounds are located in close proximity to traffic, which increases the level of air pollution and disrupts airway health in young people [2] because children are particularly vulnerable to air pollution due to underdeveloped lungs, higher breathing rate and higher metabolic rate of oxygen consumption per unit body weight [3]. The objectives of the research were to determine the following: the state of air quality at children's playgrounds in Novi Sad, Serbia with special emphasis on air quality (indicators CO<sub>2</sub>, PM<sub>2.5</sub>, PM<sub>10</sub> and VOC) and all statistically significant differences in gas emissions at different sampling points and time intervals, using MANOVA. This study is a continuation of our previous research [4]

### MATERIAL AND METHODS

The research specifically focuses on the analysis of air quality on three children's playgrounds: Playground in Futoski Park (IFP), Playground in Cara Dušana street, (ICD) and Playground in Limanski Park, (ILP) in Novi Sad. The variables used as pollution indicators are L (dB), H %, T°C, CO<sub>2</sub> (mg/m<sup>3</sup>),

VOC (mg/m<sup>3</sup>), PM<sub>2.5</sub> (µg/m<sup>3</sup>), PM<sub>10</sub> (µg/m<sup>3</sup>). The measurement of their values conducted with low-cost outdoor portable air monitors [4], [5], during the day was conducted in three time periods: measurement I, measurement II and measurement III. The aim of the research is to determine whether the level of pollution changes at three different measurements performed on these three playgrounds.

The test was designed to determine whether there is a difference in the air quality that we observe on the playground in relation to the time in which the measurement was performed. In this study, MANOVA and ANOVA analysis will be performed. The analysis was done with software tools R and SPSS15. Descriptive statistics will be performed first, followed by analysis of variance (ANOVA) and multidimensional analysis of variance (MANOVA). By analysis of variance, we test whether there is a difference in the air quality that we observe on the playground in relation to the mole - the time in which the measurement was performed.

## RESULTS AND DISCUSSION

### Descriptive statistics

The minimum, maximum value and range of each of the measured variables are presented L(dB), H%, T°C, CO<sub>2</sub> (mg/m<sup>3</sup>), VOC (mg/m<sup>3</sup>), PM<sub>2.5</sub> (µg/m<sup>3</sup>), PM<sub>10</sub> (µg/m<sup>3</sup>), as well as their mean value and standard deviation. This was done for each of the three time periods and for each of the observed playgrounds as well as the summary values.

**Table 1.** Descriptive statistics for period I

<b>IFP1</b>							
<b>IFP1</b>	<b>L(dB)</b>	<b>H%</b>	<b>T(°C)</b>	<b>CO<sub>2</sub>(mg/m<sup>3</sup>)</b>	<b>VOC(mg/m<sup>3</sup>)</b>	<b>PM<sub>2.5</sub>(µg/m<sup>3</sup>)</b>	<b>M<sub>10</sub>(µg/m<sup>3</sup>)</b>
min	64.7	48	18.1	824	49	28	32
max	68.4	51	21	857	65	31	38
range	3.7	3	2.9	33	16	3	6
st.dev.	1.134291	0.789988	1.23309	9.05721	5.107018	0.988918	1.535432
mean	65.654	49.22	19.33	842.26	58.2	29.96	33.64

<b>ICD1</b>							
<b>ICD1</b>	<b>L(dB)</b>	<b>H%</b>	<b>T(°C)</b>	<b>CO<sub>2</sub>(mg/m<sup>3</sup>)</b>	<b>VOC(mg/m<sup>3</sup>)</b>	<b>PM<sub>2.5</sub>(µg/m<sup>3</sup>)</b>	<b>M<sub>10</sub>(µg/m<sup>3</sup>)</b>
min	70.3	45	17.3	812	7	26	29
max	81.4	56	23	846	14	30	38
range	11.1	11	5.7	34	7	4	9
st.dev.	1.812371	3.045572	1.593006	11.21158	1.887013	1.216217	1.7337
mean	73.202	49.7	19.222	830.12	10.48	28.48	32.12

<b>ILP1</b>							
<b>ILP1</b>	<b>L(dB)</b>	<b>H%</b>	<b>T(°C)</b>	<b>CO<sub>2</sub>(mg/m<sup>3</sup>)</b>	<b>VOC(mg/m<sup>3</sup>)</b>	<b>PM<sub>2.5</sub>(µg/m<sup>3</sup>)</b>	<b>M<sub>10</sub>(µg/m<sup>3</sup>)</b>
min	67.7	45	17.1	824	3	26	29
max	72.3	56	23	890	5	28	31
range	4.6	11	5.9	66	2	2	2
st.dev.	1.302351	2.993939	1.618249	21.18938	0.772222	0.766918	0.766918
mean	70.298	50.66	18.562	857.7	3.66	26.94	30.06

<b>Total for period I</b>							
<b>period I</b>	<b>L(dB)</b>	<b>H%</b>	<b>T(°C)</b>	<b>CO<sub>2</sub>(mg/m<sup>3</sup>)</b>	<b>VOC(mg/m<sup>3</sup>)</b>	<b>PM<sub>2.5</sub>(µg/m<sup>3</sup>)</b>	<b>M<sub>10</sub>(µg/m<sup>3</sup>)</b>
min	64.7	45	17.1	812	3	26	29
max	81.4	56	23	890	65	31	38
range	16.7	11	5.9	78	62	5	9
st.dev.	3.43359	2.562062	1.52045	18.55277	24.54787	1.591209	2.030737
mean	69.718	49.86	19.038	843.36	24.11333	28.46	31.94

**Table 2. Descriptive statistics for period II**  
**IFP2**

<b>IFP2</b>	<b>L(dB)</b>	<b>H%</b>	<b>T(°C)</b>	<b>CO<sub>2</sub>(mg/m<sup>3</sup>)</b>	<b>VOC(mg/m<sup>3</sup>)</b>	<b>PM<sub>2.5</sub>(µg/m<sup>3</sup>)</b>	<b>M<sub>10</sub>(µg/m<sup>3</sup>)</b>
min	64.7	49	18.1	824	49	28	32
max	68.4	51	23	857	65	31	38
range	3.7	2	4.9	33	16	3	6
st.dev.	1.055251	0.725343	1.77468	9.173698	5.046559	0.961292	1.526501
mean	65.446	49.62	19.55	842.92	58.04	29.88	33.58

**ICD2**

<b>ICD2</b>	<b>L(dB)</b>	<b>H%</b>	<b>T(°C)</b>	<b>CO<sub>2</sub>(mg/m<sup>3</sup>)</b>	<b>VOC(mg/m<sup>3</sup>)</b>	<b>PM<sub>2.5</sub>(µg/m<sup>3</sup>)</b>	<b>M<sub>10</sub>(µg/m<sup>3</sup>)</b>
min	70.3	45	17.3	812	7	26	29
max	81.4	62	23	846	14	30	38
range	11.1	17	5.7	34	7	4	9
st.dev.	1.766195	4.022589	1.887195	11.06974	1.887013	1.232883	1.925235
mean	73.188	49.32	19.382	827.46	10.48	28.48	32.26

**ILP2**

<b>ILP2</b>	<b>L(dB)</b>	<b>H%</b>	<b>T(°C)</b>	<b>CO<sub>2</sub>(mg/m<sup>3</sup>)</b>	<b>VOC(mg/m<sup>3</sup>)</b>	<b>PM<sub>2.5</sub>(µg/m<sup>3</sup>)</b>	<b>M<sub>10</sub>(µg/m<sup>3</sup>)</b>
min	67.7	45	17.1	824	3	26	29
max	72.3	56	23	890	5	28	31
range	4.6	11	5.9	66	2	2	2
st.dev.	1.242775	2.980481	1.869	20.14462	0.752953	0.773014	0.739829
mean	70.12	49.88	18.748	856.52	3.62	26.88	30.06

**Total for period II**

<b>period II</b>	<b>L(dB)</b>	<b>H%</b>	<b>T(°C)</b>	<b>CO<sub>2</sub>(mg/m<sup>3</sup>)</b>	<b>VOC(mg/m<sup>3</sup>)</b>	<b>PM<sub>2.5</sub>(µg/m<sup>3</sup>)</b>	<b>M<sub>10</sub>(µg/m<sup>3</sup>)</b>
min	64.7	45	17.1	812	3	26	29
max	81.4	62	23	890	65	31	38
range	16.7	17	5.9	78	62	5	9
st.dev.	3.478655	2.910054	1.864348	18.52868	24.48019	1.58511	2.070621
mean	69.58467	49.60667	19.22667	842.3	24.04667	28.41333	31.96667

**Table 3. Descriptive statistics for period III**

**IFP3**

<b>IFP3</b>	<b>L(dB)</b>	<b>H%</b>	<b>T(°C)</b>	<b>CO<sub>2</sub>(mg/m<sup>3</sup>)</b>	<b>VOC(mg/m<sup>3</sup>)</b>	<b>PM<sub>2.5</sub>(µg/m<sup>3</sup>)</b>	<b>M<sub>10</sub>(µg/m<sup>3</sup>)</b>
min	64.7	48	18.1	835	49	28	32
max	67.6	51	23	857	65	31	38
range	2.9	3	4.9	22	16	3	6
st.dev.	0.896943	0.994064	1.502685	7.90102	4.579279	0.964894	1.44123
mean	65.372	49.54	20.59	844.68	59.36	29.74	33.38

**ICD3**

<b>ICD3</b>	<b>L(dB)</b>	<b>H%</b>	<b>T(°C)</b>	<b>CO<sub>2</sub>(mg/m<sup>3</sup>)</b>	<b>VOC(mg/m<sup>3</sup>)</b>	<b>PM<sub>2.5</sub>(µg/m<sup>3</sup>)</b>	<b>M<sub>10</sub>(µg/m<sup>3</sup>)</b>
min	70.3	46	17.3	812	7	26	29
max	81.4	62	23	846	14	30	38
range	11.1	16	5.7	34	7	4	9

st.dev.	1.810772	4.124392	1.509832	10.03227	1.805208	1.198809	2.27327
mean	73.022	51.64	20.2	823.92	11.08	28.54	32.34

**ILP3**

ILP3	L(dB)	H%	T(°C)	CO <sub>2</sub> (mg/m <sup>3</sup> )	VOC(mg/m <sup>3</sup> )	PM <sub>2.5</sub> (µg/m <sup>3</sup> )	M <sub>10</sub> (µg/m <sup>3</sup> )
min	67.7	47	17.1	824	3	26	29
max	72.3	56	23	890	5	28	31
range	4.6	9	5.9	66	2	2	2
st.dev.	1.307598	3.210696	1.550496	19.07797	0.767716	0.766918	0.728711
mean	70.228	51.76	19.438	852.48	3.68	26.94	30.14

**Total for period III**

period III	L(dB)	H%	T(°C)	CO <sub>2</sub> (mg/m <sup>3</sup> )	VOC(mg/m <sup>3</sup> )	PM <sub>2.5</sub> (µg/m <sup>3</sup> )	M <sub>10</sub> (µg/m <sup>3</sup> )
min	64.7	46	17.1	812	3	26	29
max	81.4	62	23	890	65	31	38
range	16.7	16	5.9	78	62	5	9
st.dev.	3.458636	3.217966	1.585322	17.87664	24.93604	1.515454	2.096135
mean	69.54067	50.98	20.076	840.36	24.70667	28.40667	31.95333

**Multidimensional analysis of variance**

We will test the hypothesis with the MANOVA test

**Hypothesis H0:** air quality depends on variables (L (dB), H%, T(°C), CO<sub>2</sub>(mg/m<sup>3</sup>), VOC(mg/m<sup>3</sup>), PM<sub>2.5</sub>(µg/m<sup>3</sup>), PM<sub>10</sub>(µg/m<sup>3</sup>)) and it does not differ significantly in the time of observation, i.e. the air quality on the playground is the same in different time intervals of observation, on the whole group of variables. Hypothesis H0 is tested three times, for each playground separately.

**Alternative hypothesis A0:** the air quality on the playground differs in relation to the observation time.

**Playground in Futoski Park (IFP)]**

MANOVA (multidimensional analysis of variance) for variables L (dB), H %, T (°C), CO<sub>2</sub> (mg/m<sup>3</sup>), VOC(mg/m<sup>3</sup>), PM<sub>2.5</sub>(µg/m<sup>3</sup>), PM<sub>10</sub>(µg/m<sup>3</sup>) in time period krt = 1,2,3:

**MANOVA (L, H, T, CO<sub>2</sub>, VOC, PM<sub>2.5</sub>, PM<sub>10</sub>) ~ krt**

	Df	Pillai	approx F	num Df	den Df	Pr(>F)
<b>krt</b>	3	0.22553	1.6489	21	426	0.036 *

Residuals 146

Signif. codes: 0 '\*\*\*' 0.001 '\*\*' 0.01 '\*' 0.05 '.' 0.1 ' ' 1

The level of significance is less than 0.05 and there is a significant difference in the observed group of variables with a level of 0.036 in relation to the measurement time. Hypothesis H0 is not accepted, and alternative A0 is accepted, which states that the air quality on the playground differs in relation to the measurement time.

We then performed ANOVA (analysis of variance) for each variable separately to see how much it affects the diversity of the observed traits over time on IFP.

Hypothesis H1: the level of L (dB) does not differ significantly over time (relative to the variable L(dB)).

Alternative hypothesis A1: level L (dB), differs significantly at different time intervals.



**Response L(dB):**

	<b>Df</b>	<b>Sum Sq</b>	<b>Mean Sq</b>	<b>F value</b>	<b>Pr(&gt;F)</b>
<b>krt</b>	3	2.162	0.72064	0.6701	0.5717
<b>Residuals</b>	146	157.005	1.07538		

Based on the values of Pr (> F) we have that there is NO significant difference with the variable L (Db). Hypothesis H1 is accepted.

Hypothesis H2: the level of H% does not differ significantly over time (in relation to the variable H%).

Alternative Hypothesis A2: The H% level differs significantly at different time intervals.

**Response H%:**

	<b>Df</b>	<b>Sum Sq</b>	<b>Mean Sq</b>	<b>F value</b>	<b>Pr(&gt;F)</b>
<b>krt</b>	3	4.529	1.50980	2.1047	0.1022
<b>Residuals</b>	146	104.731	0.71733		

Based on the values of Pr (> F), there was NO significant difference in the variable H%. Hypothesis H2 is accepted.

Hypothesis H3: level T°C does not differ significantly over time (relative to the T°C variable).

Alternative Hypothesis A3: The level T°C differs significantly at different time intervals.

**Response T°C:**

	<b>Df</b>	<b>Sum Sq</b>	<b>Mean Sq</b>	<b>F value</b>	<b>Pr(&gt;F)</b>
<b>krt</b>	3	46.84	15.6124	6.7452	0.0002715 ***
<b>Residuals</b>	146	337.93	2.3146		

Based on the values of Pr (> F), we have a significant difference in the variable T°C. Hypothesis H3 is not accepted.

H4: CO<sub>2</sub>(mg/m<sup>3</sup>) level does not differ significantly over time (relative to the CO<sub>2</sub>(mg/m<sup>3</sup>) variable).

Alternative hypothesis A4: CO<sub>2</sub>(mg/m<sup>3</sup>) level differs significantly at different time intervals.

**Response CO<sub>2</sub>(mg/m<sup>3</sup>):**

	<b>Df</b>	<b>Sum Sq</b>	<b>Mean Sq</b>	<b>F value</b>	<b>Pr(&gt;F)</b>
<b>krt</b>	3	170.8	56.922	0.7428	0.5282
<b>Residuals</b>	146	11187.9	76.629		

Based on the value of Pr (> F) we have that there is NO significant difference in the variable CO<sub>2</sub>(mg/m<sup>3</sup>). Hypothesis H4 is accepted.

**Response VOC(mg/m<sup>3</sup>):**

	<b>Df</b>	<b>Sum Sq</b>	<b>Mean Sq</b>	<b>F value</b>	<b>Pr(&gt;F)</b>
<b>krt</b>	3	99.1	33.026	1.3752	0.2527
<b>Residuals</b>	146	3506.3	24.015		

Based on the values of Pr (> F), there was NO significant difference in the variable VOC(mg/m<sup>3</sup>). Hypothesis H5 is accepted.

H6: the level of PM<sub>2.5</sub>(µg/m<sup>3</sup>) does not differ significantly over time (compared to the variable PM<sub>2.5</sub>(µg/m<sup>3</sup>)).

Alternative Hypothesis A6: The level PM<sub>2.5</sub>(µg/m<sup>3</sup>) differs significantly at different time intervals.

**Response PM<sub>2.5</sub>(µg/m<sup>3</sup>):**

	<b>Df</b>	<b>Sum Sq</b>	<b>Mean Sq</b>	<b>F value</b>	<b>Pr(&gt;F)</b>
<b>krt</b>	3	5.16	1.72000	1.8615	0.1387
<b>Residuals</b>	146	134.90	0.92397		

Based on the values of Pr (> F), there was NO significant difference in the variable PM<sub>2.5</sub>(μg/m<sup>3</sup>). Hypothesis H6 is accepted.

H7: the level of M<sub>10</sub>(μg/m<sup>3</sup>) does not differ significantly over time (compared to the variable PM<sub>10</sub>(μg/m<sup>3</sup>).

Alternative Hypothesis A7: PM<sub>10</sub>(μg/m<sup>3</sup>) level differs significantly at different time intervals.

**Response PM<sub>10</sub>(μg/m<sup>3</sup>):**

	<b>Df</b>	<b>Sum Sq</b>	<b>Mean Sq</b>	<b>F value</b>	<b>Pr(&gt;F)</b>
<b>krt</b>	3	4.60	1.5326	0.6807	0.5652
<b>Residuals</b>	146	328.74	2.2516		

Based on the value of Pr (> F), there was NO significant difference in the variable PM<sub>10</sub>(μg/m<sup>3</sup>). Hypothesis H7 is accepted.

**Playground in Cara Dušana Street (ICD)**

MANOVA (multidimensional analysis of variance) for variables L(dB), H%, T°C, CO<sub>2</sub>(mg/m<sup>3</sup>), VOC(mg/m<sup>3</sup>), PM<sub>2.5</sub>(μg/m<sup>3</sup>), PM<sub>10</sub>(μg/m<sup>3</sup>) in time period krt = 1,2,3:

**MANOVA (L,H,T,CO<sub>2</sub>,VOC,PM<sub>2.5</sub>, PM<sub>10</sub>) ~ krt)**

	<b>Df</b>	<b>Pillai</b>	<b>approx F</b>	<b>num Df</b>	<b>den Df</b>	<b>Pr(&gt;F)</b>
<b>krt</b>	3	0.32593	2.4726	21	426	0.0003565 ***

Residuals 146

Signif. codes: 0 '\*\*\*' 0.001 '\*\*' 0.01 '\*' 0.05 '.' 0.1 ' ' 1

The significance level is less than 0.05 and there is a significant difference in the observed group of variables with the level of 0.0003565 in relation to the measurement time. Hypothesis H0 is not accepted, and alternative A0 is accepted, which says that the air quality on the playground differs according to the measurement time.

We then performed ANOVA (analysis of variance) for each variable separately to see how much it affects the diversity of the observed traits over time on ICD.

**Response L(Db):**

	<b>Df</b>	<b>Sum Sq</b>	<b>Mean Sq</b>	<b>F value</b>	<b>Pr(&gt;F)</b>
<b>krt</b>	3	69.58	23.1938	8.3429	3.706e-05 ***
<b>Residuals</b>	146	405.89	2.7801		

Based on the values of Pr (> F), we have a significant difference in the variable L (Db). Hypothesis H1 is not accepted.

**Response H%:**

	<b>Df</b>	<b>Sum Sq</b>	<b>Mean Sq</b>	<b>F value</b>	<b>Pr(&gt;F)</b>
<b>krt</b>	3	162.28	54.093	3.8089	0.01152 *
<b>Residuals</b>	146	2073.46	14.202		

Based on the values of Pr (> F), we have a significant difference in the variable H%. Hypothesis H2 is not accepted.

**Response T°C :**

	<b>Df</b>	<b>Sum Sq</b>	<b>Mean Sq</b>	<b>F value</b>	<b>Pr(&gt;F)</b>
<b>krt</b>	3	31.29	10.4299	3.7434	0.01253 *
<b>Residuals</b>	146	406.79	2.7862		

Based on the values of Pr (> F), there was a significant difference in the variable T°C. Hypothesis H3 is not accepted.

**Response CO<sub>2</sub>(mg/m<sup>3</sup>):**

	<b>Df</b>	<b>Sum Sq</b>	<b>Mean Sq</b>	<b>F value</b>	<b>Pr(&gt;F)</b>
<b>krt</b>	3	1266.5	422.18	3.6697	0.01378 *
<b>Residuals</b>	146	16796.3	115.04		

Based on the value of Pr (> F) there was a significant difference in the variable CO<sub>2</sub>(mg/m<sup>3</sup>). Hypothesis H4 is not accepted.

**Response VOC(mg/m<sup>3</sup>):**

	<b>Df</b>	<b>Sum Sq</b>	<b>Mean Sq</b>	<b>F value</b>	<b>Pr(&gt;F)</b>
<b>krt</b>	3	24.64	8.2144	2.418	0.06867
<b>Residuals</b>	146	496.00	3.3972		

Based on the values of Pr (> F), there was NO significant difference in the variable VOC(mg/m<sup>3</sup>). Hypothesis H5 is accepted.

**Response PM<sub>2.5</sub>(µg/m<sup>3</sup>):**

	<b>Df</b>	<b>Sum Sq</b>	<b>Mean Sq</b>	<b>F value</b>	<b>Pr(&gt;F)</b>
<b>krt</b>	3	2.355	0.78503	0.5327	0.6605
<b>Residuals</b>	146	215.145	1.47360		

Based on the values of Pr (> F), there was NO significant difference in the variable PM<sub>2.5</sub>(µg/m<sup>3</sup>). Hypothesis H6 is accepted.

**Response PM<sub>10</sub>(µg/m<sup>3</sup>):**

	<b>Df</b>	<b>Sum Sq</b>	<b>Mean Sq</b>	<b>F value</b>	<b>Pr(&gt;F)</b>
<b>krt</b>	3	5.83	1.9420	0.4909	0.6891
<b>Residuals</b>	146	577.53	3.9557		

Based on the value of Pr (> F), there was NO significant difference in the variable PM<sub>10</sub>(µg/m<sup>3</sup>). Hypothesis H7 is accepted.

**Playground in Limanski Park (ILP)**

MANOVA (multidimensional analysis of variance) for variables L(dB), H%, T°C, CO<sub>2</sub>(mg/m<sup>3</sup>), VOC(mg/m<sup>3</sup>), PM<sub>2.5</sub>(µg/m<sup>3</sup>), PM<sub>10</sub>(µg/m<sup>3</sup>) in time period krt = 1,2,3:

**MANOVA (L,H,T,CO<sub>2</sub>,VOC,PM<sub>2.5</sub>, PM<sub>10</sub>) ~ krt)**

	<b>Df</b>	<b>Pillai</b>	<b>approx F</b>	<b>num Df</b>	<b>den Df</b>	<b>Pr(&gt;F)</b>
<b>Krt</b>	3	0.19476	1.4084	21	426	0.1087

Residuals 146

Signif. codes: 0 '\*\*\*' 0.001 '\*\*' 0.01 '\*' 0.05 '.' 0.1 ' ' 1

The level of significance is less than 0.05 and there is no significant difference in the observed group of variables with the level of 0.1087 in relation to the measurement time.

Hypothesis H0 is accepted, i.e. the air quality on the playground does not differ in relation to the measurement time.

Next the ANOVA (analysis of variance) was performed for each variable separately to see how much it affects the diversity of the observed traits over time on ILP.

**Response L(Db):**

	<b>Df</b>	<b>Sum Sq</b>	<b>Mean Sq</b>	<b>F value</b>	<b>Pr(&gt;F)</b>
<b>krt</b>	3	0.814	0.27131	0.1633	0.9209
<b>Residuals</b>	146	242.561	1.66138		

Based on the value of Pr (> F) we have that there is NO significant difference in the variable L(Db). Hypothesis H1 is accepted.

**Response H%:**

	<b>Df</b>	<b>Sum Sq</b>	<b>Mean Sq</b>	<b>F value</b>	<b>Pr(&gt;F)</b>
<b>krt</b>	3	102.88	34.294	3.6655	0.01385 *
<b>Residuals</b>	146	1365.95	9.356		

Based on the values of Pr (> F), we have a significant difference in the variable H%. Hypothesis H2 is not accepted.

**Response T°C:**

	<b>Df</b>	<b>Sum Sq</b>	<b>Mean Sq</b>	<b>F value</b>	<b>Pr(&gt;F)</b>
<b>krt</b>	3	23.48	7.8274	2.7531	0.04476 *
<b>Residuals</b>	146	415.10	2.8431		

Based on the values of Pr (> F), there was a significant difference in the variable ToC. Hypothesis H3 is not accepted.

**Response CO<sub>2</sub>(mg/m<sup>3</sup>):**

	<b>Df</b>	<b>Sum Sq</b>	<b>Mean Sq</b>	<b>F value</b>	<b>Pr(&gt;F)</b>
<b>krt</b>	3	1908	636.08	1.5858	0.1953
<b>Residuals</b>	146	58561	401.10		

Based on the value of Pr (> F), there was NO significant difference in the variable CO<sub>2</sub>(mg/m<sup>3</sup>). Hypothesis H4 is accepted.

**Response VOC(mg/m<sup>3</sup>):**

	<b>Df</b>	<b>Sum Sq</b>	<b>Mean Sq</b>	<b>F value</b>	<b>Pr(&gt;F)</b>
<b>krt</b>	3	1.926	0.64186	1.115	0.3451
<b>Residuals</b>	146	84.048	0.57567		

Based on the value of Pr (> F), there was NO significant difference in the VOC(mg/m<sup>3</sup>). Hypothesis H5 is accepted.

**Response PM<sub>2.5</sub>(µg/m<sup>3</sup>):**

	<b>Df</b>	<b>Sum Sq</b>	<b>Mean Sq</b>	<b>F value</b>	<b>Pr(&gt;F)</b>
<b>krt</b>	3	0.124	0.04122	0.0692	0.9762
<b>Residuals</b>	146	86.916	0.59532		

Based on the value of Pr (> F), there was NO significant difference in the variable PM<sub>2.5</sub>(µg/m<sup>3</sup>). Hypothesis H6 is accepted.

**Response PM<sub>10</sub>(µg/m<sup>3</sup>):**

	<b>Df</b>	<b>Sum Sq</b>	<b>Mean Sq</b>	<b>F value</b>	<b>Pr(&gt;F)</b>
<b>krt</b>	3	1.360	0.45329	0.822	0.4837
<b>Residuals</b>	146	80.513	0.55146		

Based on the value of Pr (> F), there was NO significant difference in the variable PM<sub>10</sub>(µg/m<sup>3</sup>). Hypothesis H7 is accepted.

## CONCLUSION

Levels of concentration of carbon dioxide, particles and volatile organic compounds were determined in three playgrounds in Novi Sad, Serbia, for a measurement period of over 50 days. The main factor influencing the presence of target hazards was the time interval. However, the obtained concentrations of pollutants were lower than the values prescribed by STEL and PEL, indicating still acceptable conditions for children's play in terms of health. The obtained data set was analyzed using MANOVA, ANOVA for statistical investigation of significant differences in pollutant emissions by observing different sampling points and time intervals. The ANOVA results confirmed a statistically significant difference in temperature at all three playgrounds, relative humidity in the case of ICD and ILP, and CO<sub>2</sub> in the ICD indicating that the sampling point and time interval contributed most to pollutant levels in the playground environment. The concentrations of air pollutants CO<sub>2</sub>, VOC, PM<sub>2.5</sub> and PM<sub>10</sub> in the air of the city of Novi Sad within the range of acceptable limits.

## ACKNOWLEDGEMENT

Authors are supported by the Ministry of Education, Science and Technological Development through the Project No. 451-03-68/2020-14/200156 and the City Administration for Environmental Protection, Novi Sad, Republic of Serbia, within the Project No. VI-501-2/2018-18B-21.

## REFERENCES

- [1] Rim D, Gall ET, Kim JB, Bae G-N (2017) Particulate matter in urban nursery schools: a case study of Seoul, Korea during winter months. *Build Environ* 119:1–10. <https://doi.org/10.1016/j.buildenv.2017.04.002>
- [2] Sunyer J, Esnaola M, Alvarez-Pedrerol M, Fornas J, Rivas I, LópezVicente M, Suades-González E, Foraster M, Garcia-Esteban R, Basagaña X, Viana M, Cirach M, Moreno T, Alastuey A, Sebastian-Galles N, Nieuwenhuijsen M, Querol X (2015) Association between traffic-related air pollution in schools and cognitive development in primary school children: a prospective cohort study. *PLoS Med* 12(3):e1001792. <https://doi.org/10.1371/journal.pmed.1001792>
- [3] Branco PTBS, Alvim-Ferraz MCM, Martins FG, Sousa SIV (2014) Indoor air quality in urban nurseries at Porto city: particulate matter assessment. *Atmos Environ* 84:133–143. <https://doi.org/10.1016/j.atmosenv.2013.11.035>
- [4] Jelena S. Kiurski, Nebojša M. Ralević, Svetlana D. Ignjatijević, Jelena M. Vapa-Tankosić, Dragan Đ. Soleša, Analysis of air quality indicators at children's playgrounds, *Air Quality, Atmosphere & Health*, 12(8), 955-962 (2019), Springer Netherlands, ISSN: 1873-9318 (Print) 1873-9326 (Online), <https://doi.org/10.1007/s11869-019-00712-w>
- [5] Aeroqual Limited (2019) Aeroqual Product catalogue <https://www.aeroqual.com/outdoor-air-quality/outdoor-portable-air-monitors>

## HAZARDS AND HARMS FROM USING CHEMICAL SUBSTANCES

Jasmina Rajić<sup>1</sup>, Aleksandar Šotić<sup>1</sup>, Barbara Vidaković Ristić<sup>1</sup>,  
Dragana Paunović<sup>2</sup>, Tanja Petrović<sup>2</sup>

<sup>1</sup>Academy of Applied Technical Studies Belgrade, Belgrade, Serbia,

<sup>2</sup>Faculty of Agriculture, University of Belgrade, Belgrade, Serbia

e-mail: [jrajic@tehnikum.edu.rs](mailto:jrajic@tehnikum.edu.rs)

**Abstract:** Chemicals are in widespread use, of essential importance and their advantages are recognized worldwide. Their use is mainly associated with industrial plants, however, almost each type of workplace utilizes chemicals, and thereby a large volume of workers is potentially exposed to their impact. The aim of this paper is to raise awareness of how dangerous chemicals can be to humans and the environment if they are not handled with sufficient care and knowledge. Contemporary technological processes bring new working conditions and exposure to new unknown harmful substances (toxic, carcinogenic, flammable, explosive, corrosive, radioactive, etc.), which cannot be completely eliminated even with the most modern technical, hygienic, and personal protection measures. Yet, the control of exposure to these chemical substances and their limited emission to the environment are the tasks of both the employer and employees.

**Key words:** chemical substances, chemicals, exposure, risk, safe and health work

### INTRODUCTION

More than 50 million different chemical substances have been isolated or synthesized, the majority over the past decades. About 70 000 different chemicals are in use across the planet, and the assessment that approx. 200 – 1000 new chemicals are produced annually is of great concern, while the number of mixtures is even greater, [1]. Such large production and use of chemical substances have increased the number of diseases, chemicals being their direct or indirect causes, [2-4]. The problem is the price we pay with the health, which we are not sufficiently informed about and are often unaware of.

### USE OF CHEMICAL SUBSTANCES

Chemicals are widely used in industry and our daily lives. Use of chemicals such as paints, lacquers, thinners, glue, oil, heavy metals in industrial plants of chemical and petrochemical industry, at the construction sites, in manufacturing of tyres, plastics, cars, is strictly controlled and under legal regulation, [5-8]. However, today many substances are strictly controlled but after great consequences they have produced. This is all the result of the lack of available knowledge about harmful effects of the substances for human health before the chemicals entered mass consumption. For this reason, in order to control exposure to harm from chemicals, it is necessary, first of all, to know the characteristics of substances we are handling so as to undertake adequate measures in packaging, transport and manipulation of those substances. Besides, it is necessary to point to enormous harms that can be a consequence of the exposure of all humans to chemicals, [9], primarily of those who are exposed to adverse impacts of chemicals in their workplaces, [5]. Also, chemicals can be useful or harmful for humans depending on the manner they are utilized.

Thus, pesticides, applied to the crops in agricultural production, have been increased in their range and quality, which increases the volume of food industry production, additives improve sensory properties of food products, pharmaceutical products aid in disease treatment and contribute to human health. However, uncontrolled use of these chemical compounds may produce harmful effects on human health. Cleaning products contribute to good hygiene, but may have negative effects on those who use them as a means of labor or are exposed to them every day. Also, pesticides are directly emitted to the air, or can get into watercourses, or can be persistent for years in soil. Excessive use of fertilizers and uncontrolled discharge and treatment of wastewater often leads to contamination of groundwater with phosphates and nitrogen and other organic and inorganic compounds, which, if present in a concentration higher than prescribed, can pose a danger to aquatic wildlife but human health too. To avoid hazards of using water where these compounds are present, inspection of drinking water hygiene must be done very frequently, according to the Regulation, [10-12]. And yet, workers involved in the manufacturing process and use

of those chemicals are exposed to their bad effects. Additionally, residues of production and chemicals application may cause adverse ecological impacts that remain for years after utilization.

In contemporary urban society we also communicate daily with metals, including metal contaminants in water, food and air, as well as metal traces in industrial products (drugs, plastics, etc.). It is almost impossible to avoid completely such indirect contact with a component containing metal. In routine laboratory practice a researcher usually deals with small quantities of metal compounds, which are safe if handled properly. However, in large scale industrial processes considerable quantities of metals can reach water bodies. Data are collected in the laboratories and it is often difficult to extrapolate into industrial practice due to differences in the quantities of chemicals and their operational routes. Consequently, we should be aware that in real life the compounds containing metals can impact living organisms in different ways. The toxicity of metals should be viewed as a constant characteristic: it may vary depending on the oxidation state, ligand, compound solubility and morphology, and may be significantly affected by the environment, [13].

Almost any type of workplace uses chemicals, therefore a large range of workplaces are potentially exposed to their impact. Harmful effects of chemicals depend on the exposure level and amount for handling, but there is no sector that can be simply excluded from mandatory prevention and control of hazardous substances. Over the past years there has been a growing concern about chemicals utilized in beauty salons, printing houses, dental offices due to acrylates and other chemicals. In such facilities consumers are rarely and short-term exposed, which differs from the exposure of workers using them every day. Attention should be especially directed to proper prevention and protection measures such as adequate ventilation, protective equipment, or worker training, [14].

The dynamics of research on safety and health aspects of chemicals is too slow compared to the development rate and use of chemicals. Nanotechnologies are involved in manufacturing very small structures, usually 1 – 100 nm in size, whose production is released prior to proper risk assessment, thus exposing workers to unknown risks. Scientific and ecological organizations are also involved in providing advice related to the issues on nanotechnology and environment, [15].

Many individual chemical substances are inadequately assessed regarding their effects on safety and health. The mixture of such substances is generally characteristic for a workplace but is infrequently assessed or tested in the mixture form. The majority of workers are exposed to mixtures rather than to single chemical substances, and thereby the control of mixed exposure is of essential importance for efficient protection program.

## **HARMFUL EFFECTS (TOXICITY) OF CHEMICALS**

Toxicology is a science that studies toxins and their impacts on human body. Many useful products are synthesized from chemical substances such as plastics, paints, pharmaceutical products, detergents, etc. Some chemicals may act harmlessly but may have adverse impact on health immediately after the contact or a longer-term exposure. Some harmful effects on health develop only after extended exposure and after the latent period. They may enter the body by inhalation and swallowing (with rapid chemical absorption) or by skin contact (with commonly less rapid absorption). Exposure by inhalation and skin represent the major routes of exposure to hazardous substances at work. Skin absorption of chemicals may occur without worker's perception of it (e.g. pesticides, organic thinners). Fat soluble pesticides are mainly absorbed through skin and mucosa. For such forms of exposure workers are obliged to wear protective clothing for skin, including gloves and safety glasses. Chemicals can get quite unnoticed into the digestive system when workers eat, drink, or hold a cigarette, with their contaminated hands in the workplace.

Occupational diseases that may occur are related to any disease caused by the exposure to the factors deriving from work activity, [2-4]. A list of occupational diseases, as prepared by the International Labor Organization, contains four major groups: occupational disease caused by the exposure to agents resulting from work activities (such as chemical, physical, biological agents); occupational disease by target organ systems; occupational cancer; and other diseases, [16]. Chemical agents are the most common occupational risk that may lead to an occupational disease, [2-4].

Effects of chemicals on health can be local, which do not occur at the contact point with the body, like skin or eye irritation or systemic, which occurs at the point away from the chemical entry route such as liver or kidney damage. Also, health effects can be acute, instantaneous, which is the result of short-

term and often high exposure, and chronic effects that represent a postponed start of the health effects after cumulative exposure to chemicals. Additionally, effects on health from the exposure to chemicals can be reversible (temporary – dermatitis due to the exposure of mild irritants), or irreversible – permanent health changes that cannot be repaired (cancer, silicosis and asbestosis, [2-4]).

However, chemicals can be used safely if exposure is kept below tolerance limits, [5, 7]. There are various factors that influence the toxicity and health effects of a chemical agent – man's physical condition exposed to chemical effects, chemical dose and concentration, aerodynamic diameter or size, absorption route, exposure duration, presence of other chemicals, worker vulnerability to harmful effects of some chemical (genetic factors, age, sex, health condition, hypersensitivity, personal habits and hygiene, pregnancy, breastfeeding, etc.).

In order to assist the countries in prevention, recording and notification, and if applicable, compensation for diseases caused by labor, a list of occupational diseases has been composed, which reflects the most contemporary identification and recognition of occupational diseases. Most of the occupational diseases listed are caused by chemical agents and their prevention can save lives, enhance worker life quality and significantly reduce social costs of chemical exposure, [16].

Exposure to chemical harms can have a variety of adverse consequences for human health. The effects of their activity are recorded only after great 'incidents' with human casualties. The toll of occupational diseases due to chemical exposure is very large. Chemical substances can cause tissue damage of the skin, eyes, respiratory system, nerves and other elements of the CNS. They can prevent oxygen-binding in blood and cause a series of other damages in the cardiovascular system. Apart from conditioning instantaneous damages of the organs, chemicals often cause consequences which are invisible immediately. Some chemicals can have harmful effects after a single exposure, whereas others can cause damages after a long-term exposure to that substance, so after a long-term exposure to carcinogens a cancer can develop, [2-4].

Chemical substances have a broad spectrum of potentially adverse impacts, from health risks such as carcinogenicity, physical such as flammability, to ecological such as widespread contamination and toxicity for living organisms. Many fires, explosions and other disasters are the result of inadequate physical risk management. This way, ecosystems and infrastructures are endangered, and pollutants and combustion products are spread. Yet, the knowledge about hazard and related risks from chemicals that reach the environment has significantly grown over the past 40 years. This rise of awareness comes from the progress in our ability to measure the chemicals at low concentrations in the environment, recognition of a series of effects on organisms and world rise in expertise level, [17-21].

## **SAFETY IN THE USE OF CHEMICALS AT WORK**

Hazardous chemical substances, often referred to in literature as hazardous substances, are a constituent part of the functional, technically highly developed industrial society. They are used for different purposes as a raw material, semi-finished product or finished product necessary for the development of some technological process, to the use in doing some daily jobs, [22].

Chemical correctness has become over years one of the areas where increasing attention is devoted to safety and health at work. In the past years significant progress has been achieved regarding legal provisions and management of chemicals. Of great importance is proper handling of hazardous chemicals, training of employees working with them, proper storage, disposal of hazardous substances in landfills, and their destruction. It should be also noted that chemicals are utilized for home use and, in that case, attention should be paid to the label that provides necessary information for a customer.

Governments, employers and employees continue to make efforts to minimize harmful effects in applying hazardous substances at both national and international level, [5-8, 23]. However, it is still insufficient. Serious incidents continue to occur and there are still adverse impacts on both human health and the environment. Employees exposed directly to hazardous substances should have the right to work in the safe and health environment, to be properly informed, trained and protected.

A large number of chemicals, in daily use, can seriously endanger human health and that of other living beings, [1]. It is of great importance to properly handle hazardous substances. Responsibility is necessary equally on the part of a manager and employees to avoid some harmful consequences of dangerous substances management. Yet, this is regulated by provisions in order to enhance working and living environment conditions, as well as personal rights that all employees have and their obligations,



including the employer. It is well-known that each job involves certain obligation and responsibility. In order to improve the efficiency of all provisions, it is not enough to be well acquainted with provisions but to apply them for as much good protection as possible, [5, 7, 9]. To safely handle chemical substances is of crucial importance, as well as the manner a chemical penetrates into the body, because chemicals can endanger human and all living beings' health, even of those unborn, [3-4]. Based on the knowledge about dangers and harms that can be produced by chemical substances, training of employees is significant for safe and health work, and their health condition monitoring, [5]. Education is part of the training whose aim is to raise awareness of all those using chemical substances, [3-4].

Boundary values of chemical action exposure in workplace are standards developed as directives for health risks control and safe levels of exposure to various chemical and physical agents that can be present in workplace. It was recommended or a mandatory numerical boundary for a single chemical exposure in workplace. The boundary values commonly establish the level of average temporal exposure that is expected to prevent most of the effects on workers' health exposed to a specific chemical during full-time hours worked. There can also exist limits for short-term exposure or upper limits that should not be exceeded at any cost, [5].

Overall strategy for achieving safe chemical management in workplace and environment protection can be simply explained as follows: the first step includes identification of which chemicals are present, then their classification according to toxicological (effects on human health), physical and chemical and ecotoxicological properties (effects on the environment). The next step involves preparation of labels and safety data sheets and related protective measures, [8]. Without such information about chemicals in the workplace or about those emitted in the environment, it is impossible to move forward in assessing the effects and establishing appropriate preventive measures and control. Information provides basic structure necessary to accomplish safe chemical management, [5]. The second step is the assessment of the way the identified and classified chemicals are used in the workplace, and what kind of exposure can result from that use. When establishing the presence of chemicals in the workplace, risk assessment must be done to determine measures for preventing, eliminating or reducing current risks caused by chemical substances, [5, 7]. Methods for risk assessment in chemical exposure differ in their thoroughness. In order that risk assessment produces sufficiently good results, it is necessary to select a licensed person as well as to choose an adequate method that fulfills all necessary conditions for a given chemical. Besides, risk assessment is efficient if it is acted upon, that is, if it is monitored through all needed activities, and should be considered regularly. This can be accomplished through exposure supervision, or by applying the tools that allow exposure assessment based on factors involving the quantity used, discharge possibility with respect to workplace or facility conditions, and chemical substance physical characteristics. After the hazards are identified, classified, reported and risks are assessed, the third and last step involves employment of information to compose an adequate prevention and protection program in workplace. It implies various types of prevention and control measures, including introduction and application of technical control, substitution of chemicals with less risky ones, and use of respiratory and personal protective equipment when necessary, [5, 7]. Also, monitoring is conducted for exposure, notification and training of exposed workers, recording, medical supervision, planning for the case of emergency and disposal procedure.

## **CONCLUSION**

From all stated above it can be concluded that safe and health work when using chemicals plays a significant role in preserving the lives of people and the environment. It is everybody's duty and obligation to implement measures for safe and health work, both of the employer and the employees. However, it often happens that in practice it is not like that so the application of legal measures is affected. Yet, it should be noted that investing into safety at work or improving working conditions is profitable bringing in profits for the enterprise (employer), but employees have profits too. Also, thorough knowledge of technological process and discovery of danger and harm presence is very significant in employees protection. Actually, if measures for safe and health work are not conducted in workplace and occupational environment, the consequences will be felt on the other side and the error will be paid by both society and state. Investment in protection measures means reduction in sick leaves, injuries at work, occupational diseases, fires, unplanned stoppages, compensation for employees, treatment costs, etc. To obey regulations and certain rules, treatments and procedures on the part of the

employer implies less injuries, less occupational diseases and diseases in general, less personal and family traumas, more happiness and satisfaction. Like any other occupational disease, the disease due to chemical hazards exposure can be prevented. Control measures, especially primary prevention measures should be applied for the sake of worker health protection and safety and prevention of undesired effects of chemical exposure.

## REFERENCES

- [1] Connell, D., W., Lam, P., Richardson, B., Rudolf W.: Introduction to Ecotoxicology. Hoboken, NJ, USA: Wiley-Blackwell, 44-80, 2009.
- [2] Key, M.M., Ede, L.: Occupational diseases: a guide to their recognition, U.S. Department of health, education, and welfare, Washington, 1977.
- [3] Fitzpatrick, R.B.: Haz-Map: information on hazardous chemicals and occupational diseases, Medical reference services quarterly, 23(2), 49-56, 2004.
- [4] Lim, J.W., Koh, D.: Chemical Agents that Cause Occupational Diseases, The Wiley Blackwell Encyclopedia of Health, Illness, Behavior, and Society, 2014.
- [5] "Official Gazette of the Republic of Serbia", No 106/2009 and 117/2017. Regulations of prevention measures for safe and health work in chemical substances exposure.
- [6] "Official Gazette of the Republic of Serbia", No 36/2009, 88/2010, 92/2011, 93/2012 and 25/2015. Law on chemicals.
- [7] "Official Gazette of the Republic of Serbia", No 101/2005, 91/2015 and 113/2017. Law on safety and health at work.
- [8] "Official Gazette of the Republic of Serbia", No 100, December 29, 2011. Regulation on the safety sheet contents.
- [9] Šotić A, Ivetić M.: Public health risk analysis through evaluation of drinking water safety. Vojnosanit Pregl. 73(9), 885–887, 2016.
- [10] Rajić, J., Šotić, A.: The origin of nitrites and nitrates in nature and Determination of their content in drinking water, IX International Conference Industrial Engineering and Environmental Protection 2019 (IIZS 2019), 387-390, Zrenjanin, Serbia, 2019.
- [11] Rajić, J., Šotić, A.: Ammonia within nitrogen cycle process and its Presence in drinking water, IX International Conference Industrial Engineering and Environmental Protection 2019 (IIZS 2019), 382-386, Zrenjanin, Serbia, 2019.
- [12] Regulations of drinking water disinfection and inspection, Official Gazette of the Republic of Serbia, No 60/81, Belgrade, Serbia.
- [13] Egorova, K. S.: Ananikov, V. P. Toxicity of Metal Compounds: Knowledge and Myths, Organometallics, 36, 4071–4090, 2017.
- [14] Kiec-Swierczynska, M., Krecisz, B., Chomiczewska-Skora, D.: Occupational contact dermatitis to acrylates in a manicurist, Occupational Medicine, 63(5), 380–382, 2013.
- [15] Hannaha, W., Thompson, P. B.: Nanotechnology, risk and the environment: a review, Journal of Environmental Monitoring, 10, 291-300, 2008.
- [16] ILO, Final report: Meeting of experts to investigate instruments, knowledge, propagation method, technical cooperation and international cooperation as a tool for developing the framework of standards for hazardous substances, Geneva, Dec. 10-13, 2007.
- [17] Vidakovic, M., Vidakovic, B.: Fire and architectural engineering, Handbook, Fahrenheit, Belgrade, 2008.
- [18] Vidakovic, B., Banjac, M., Rajic, R.: Fire risk management in traffic tunnels, 8th international counseling on risk and safety engineering, Proceedings, 212-217, Kopaonik, Feb. 2-9, 2013.
- [19] Banjac, M., Vidaković B.: Challenges of Tomorrow – Fire Hazard of Systems Using Renewable Sources of Energy, Jurnal of Energy and Power Engineering, Vol 8, 2014.
- [20] "Official Gazette of the Republic of Serbia", No 135/2004, 36/2009, 36/2009 - etc. Law, 72/2009 – etc. Law, 43/2011 – US decision, 14/2016, 76/2018, 95/2018 – etc. Law and 95/2018- etc. Law. Law on environment protection.
- [21] Johnson, A.C., Jin, X., Nakada, N., Sumpter, J.P.: Learning from the past and considering the future of chemicals in the environment, Science, 367(6476), 384-387, 2020.

- [22] Carson, P.: Hazardous Chemicals Handbook, 2nd ed., ButterworthHeinemann, Oxford, Woburn, 2002.
- [23] Regulation (EC) No 1907/2006 of the European Parliament and of the Council of 18 December 2006 concerning the Registration, Evaluation, Authorisation and Restriction of Chemicals (REACH).

Session 7:

# **Environmental Management**

## GREEN HUMAN RESOURCES MANAGEMENT AND ENVIRONMENTAL PROTECTION

**Dragana Milosavljev<sup>1</sup>, Edit Terek Stojanović<sup>1</sup>, Mila Kavalić<sup>2</sup>, Maja Gaborov<sup>1</sup>,  
Mihalj Bakator<sup>1</sup>**

<sup>1</sup>University of Novi Sad, Technical Faculty "Mihajlo Pupin", Zrenjanin, Serbia

<sup>2</sup>University of Novi Sad, Faculty of technical sciences, Novi Sad, Serbia

e-mail: [milosavljevd@yahoo.com](mailto:milosavljevd@yahoo.com)

**Abstract:** The growing interest in environmental protection and sustainability has led to the emergence of a new focus of research in the field of human resource management. Scientists in this field have begun to explore how human resource management can significantly contribute to the achievement of sustainable environmental goals and thus the practice of green human resource management has emerged. Green human resource management is a relatively new concept, which refers to a set of human resource management activities, which are aimed at protecting the environment. This paper explains the concept and importance of green human resource management, and will present the functions of green human resource management and explain the benefits that organizations gain by implementing this concept.

**Key words:** green human resource management, environmental protection, sustainability

### INTRODUCTION

One of the features of modern business is globalization, which has its ecological dimension. This dimension refers to the danger of an ecologically destructive way of production (depletion of raw materials, pollution, climate disturbances), which calls into question the further survival of the world. Climate change and the depletion of natural resources, due to the development of industry, are one of the greatest challenges facing humanity. Given the fact that the environment can be considered a major constraint in maintaining economic growth, environmental protection has become an imperative of developed and developing countries [1], [2]. Thus, sustainability and environmental protection are critical organizational goals, and one of the greatest challenges facing organizations is to achieve balanced economic, social and environmental development. Organizations are allocating more and more resources to solve environmental problems. The primary goal of organizations is to stabilize the development of industry, which will not or will endanger the environment to the least possible extent [3]. As the preservation of the natural environment in the business world has become a "megatrend", as a result, organizations are developing practices related to nurturing environmental awareness, as part of their organizational strategy, also known as green management [4]. The development of green management has occurred as a result of the application of environmental management practices, which have brought numerous benefits to organizations. Some of the advantages associated with the application of green management are the reduction of total costs, better cooperation with external stakeholders, better business performance, building a better reputation of the organization, etc. [2], [5]. Global environmental problems and pressures have made business organizations more aware of the need to turn their efforts towards environmental protection. Organizations around the world first tried to optimize their production processes by introducing the concept of green production, which means minimizing waste, applying Kaizen, Six Sigma, Lean concept and Jidoke. "Greening" of business is included into various functional domains of the organization in the form of green marketing, green supply chain, green accounting, green human resource management [1]. Within the framework of environmental protection, effective green management requires significant human resources. In that direction, human resource management, as a management function, received great attention in the literature and environmental management. Human resource management enables an organization to develop human capital that can improve environmental performance and promote sustainable development [6]. Combining human resource management with environmental management is called green human resource management (GHRM) [7].

GHRM was created as a result of the great need of organizations to integrate environmental sustainability into their business models and is applied to implement green strategies and achieve

green goals of organizations [8]. GHRM includes the adoption of various human resource management practices, such as: recruitment, selection, training and coaching, performance management, rewards, employee involvement in improving the environmental performance of the organization [9]. GHRM is designed to play a significant role in achieving sustainable development in an organization, shaping organizational culture, structure, strategy, and policy [10].

## **THE CONCEPT OF GREEN HUMAN RESOURCES MANAGEMENT**

Growing public concern for environmental sustainability has increased pressure on industry to address environmental issues and to implement responsible management [11], [12], [13]. As a result, organizations are required to implement strategies and practices that will achieve their economic goals, but also protect the environment. The success of any organization in achieving environmental performance depends on the environmental behavior of its employees. In order for organizations to achieve environmental sustainability, it is important to understand how human resource management affects the environmentally friendly behavior of employees [13]. In order to gain a competitive advantage, organizations are forced to incorporate environmental practices into their human resources policy. This means that the role of the human resources manager is to provide training and empower employees to work in accordance with environmental sustainability [14].

The term green human resource management (GHRM) is used more and more and indicates a phenomenon whose importance is growing every day. In the broadest sense, GHRM is closely linked to sustainable development, including not only awareness of environmental issues, but also awareness of the importance of social and economic benefits, both for the organization and its employees [15]. GHRM is defined as the inclusion of green management elements in job design, recruitment, training and development, motivation and human resource management, in order to improve employee behavior in terms of environmental protection, meet employee expectations and achieve organizational goals [3]. Opatha and Arulrajah have defined GHRM as practices related to the formation, implementation and maintenance of an organizational structure that makes employees pro-environmental. It involves changing the usual workforce into a "green" workforce, in order to achieve green goals and participate in environmental sustainability [16]. Thus, GHRM involves the use of different human resource management practices to strengthen environmental goals and develop a workforce that is environmentally conscious and committed to the goal of environmental sustainability. GHRM may include prioritizing environmentally conscious employees in the recruitment process (green employment), establishing a learning and development system to improve environmental awareness and environmental management skills (green training), measuring employee contributions to environmental goals (green performance management), distribution financial and non-financial rewards to employees for showing environmental attitudes and behavior (green reward management) and providing employees with opportunities to engage and participate in environmental management activities in the organization (green participation) [1], [17]. GHRM plays an important role in achieving ecological balance, economic stability and demands for the sustainability of health, well-being, social equality and well-being of organizations and their employees. The key drivers of GHRM are: senior management support for green activities, green training, formation of green teams, impact assessments and awards based on green criteria, involvement of employees in environmental management, green organizational learning and green organizational culture [18], [19].

In order for human resource management to meet the needs of strategic commitment to a sustainable living environment, it is necessary to make certain changes to existing human resource management. Therefore, there are several steps in introducing green human resource management into an organization (Figure 1) [15]:

- Evaluation - first of all it is necessary to determine whether the organizational culture, strategy and values in the organization support the goals aimed at sustainability and environmental protection. It is very important to determine whether the organization is involved in any type of service delivery to the community and society, which contributes to environmental protection through its "green" business;
- Elimination - Human resource management should support the green movement in the organization by reducing costs that will help in reducing the amount of waste that organizations produce, as well as in the rational consumption of energy and materials. This

will be for e.g. achieved: by using recycled paper, double-sided printing, turning off lights and appliances when leaving the premises, not using disposable glasses, etc .;

- Shed light on - Human resource management will need to develop an authentic employment brand, which will be consistent in helping the organization find, retain or when necessary fire employees who do not and do not want to develop environmental awareness. On the other hand, this managerial function is expected to enable employees to use environmentally friendly products, in order for the said brand to remain consistent;
- Implementation - human resource management must implement a strategy of sustainable development, by "painting in green" each phase of the employee's stay in the organization - from recruiting to rewarding employees.



**Fig. 1.** Steps in introducing GHRM into an organization

## **FUNCTIONS OF GREEN HUMAN RESOURCES MANAGEMENT**

Green human resource management, as a whole, refers to the promotion of sustainable practices, which are related to the environment, by increasing the awareness and commitment of employees regarding environmental sustainability issues [20]. Such initiatives include the adoption of efficient environmentally sound human resource management practices, which result in greater efficiency, greater cost reductions, and increased employee engagement. GHRM focuses on the integration of human resource management practices, which support the reduction of negative environmental impacts and / or the strengthening of positive environmental impacts, in line with the ultimate organizational goals [4].

As with human resource management, green human resource management has four basic functions:

- personnel function;
- training and development function;
- motivational function;
- maintenance function.

The personnel function includes green job analysis and design and green recruitment and selection. Job analysis is a systematic process that analyzes work duties, responsibilities and working conditions. From a green management perspective, it can be used to identify work tasks and responsibilities related to environmental management. These responsibilities may include, but are not limited to, environmental reporting, as well as occupational health and safety responsibilities. Some organizations even go so far as to introduce jobs that focus exclusively on the environmental management of their operations [3], [4]. Research has shown that people today prefer to work in socially responsible organizations, hence recruitment and selection of employees involves attracting candidates with appropriate skills, which are directly related to sustainable development and environmental protection. Candidates' expertise, their knowledge and skills are one dimension, while their awareness of environmental protection is another. Many organizations use their focus on sustainable development and environmental attitudes as a key point in recruiting new candidates. Some of them consider their friendly attitude towards ecology to be the basis of a brand focused on employment, while some go a step further, not only are they engaged in environmental practices, but also regularly publish their environmental reports [21]. When it comes to selection, the care of employees towards the environment is crucial, and not only those who are sufficiently aware of the concept of "greening" are proposed for the selection of candidates, but also those who possess positive personal values, such as openness to change [22].

The training and development function includes green training, development and education in the field of environmental protection. The development program must begin with the adoption of the necessary knowledge of ecology, environmental protection, sustainable development, as well as green practices. Such a development program, which includes the necessary environmental education, should be

established together with environmental policies and important procedures regarding environmental protection. When planning this program, the roles of employees in the organization should be taken into account, and it should be regularly updated, so that it is always in line with other policies and procedures of the organization [23]. Green training and education are conducted in response to the necessary changes related to organizational operations related to the environment. The best way for employees to develop is to be more engaged in the implementation of environmental initiatives that is the implementation of environmental training and education, as well as the introduction of environmental culture among employees. Green training should be developed at all levels, from training on technical safety and health at work, at the lowest levels, to strategic environmental issues, at the executive and management levels [20]. Through education, training and development, employees should become acquainted not only with various aspects related to environmental management, but also with their beliefs and attitudes become an integral part of the organizational culture aimed at creating a healthy living and business environment.

The motivational function includes: green performance management, green reward management, and green health and safety. Green performance management refers to the practice of assessing the performance of individuals, through benefits, during the practice of green management. Setting green performance indicators requires the creation of a set of environmental measures for all employees in environmental impact assessment. Many organizations have set environmental performance standards so that they can determine their green performance when collecting environmental data. Green performance and reward management includes setting green performance targets, using green indicators or setting standards for assessing green performance, identifying contributions to environmental goals, and using financial and non-financial rewards to achieve better environmental performance [9]. So, a very important aspect of GHRM are green awards. Thanks to green benefits and rewards, employees feel valued, which will lead to them being more motivated to continue with behavior that is in line with environmental practices. Rewards aimed at environmental goals can stimulate employee actions and improve long-term results so much that some organizations have taken environmental assessment into account when calculating employee salaries. Green rewards can be of financial or non-financial nature. Financial rewards include cash prizes, bonuses and incentives, while non-financial rewards may include various recognitions, free travel or various incentives [24]. Providing a green workplace is a central function of GHRM for all employees. Companies are constantly allocating resources to launch various environmental-related initiatives, which would reduce stress and illness at work caused by harmful work environments [3].

The maintenance function includes: green labor relations and employee involvement, as well as measuring GHRM. In the context of GHRM, employee relations and collective bargaining are essential to the execution of an organization's environmental management plans and programs. The full participation of employees in environmental management is important for achieving significant results, as employees are considered to be the ones who encourage organizations to address environmental issues. Involving employees in environmental management involves three processes: identifying tacit knowledge of employees through observation of production processes in which employees participate; engaging and empowering employees to make environmental improvements in the organization and developing an organizational culture that supports the improvement of environmental protection [22]. Thus, employees must be given the opportunity to participate in environmental management, which will further stimulate them to support the prevention of pollution, as well as to identify opportunities to improve environmental protection. Numerous studies have shown that involving employees in the environmental sector is key to improving the performance of environmental management systems, such as reducing waste and pollution in the workplace and making full use of resources [25]. Measuring GHRM should take into account the green idea, training, assessment of green performance of individuals and offering rewards. In order to describe the level of achievement in the field of GHRM, organizations require certain indicators, for this reason it is necessary to develop valid GHRM measuring instruments [3].

In the current situation during the COVID 19 pandemic, the role of health and safety management is increasing. The creation of socially responsible, resource-productive, environmentally sensitive jobs, which would improve the health of employees, reduce stress and burnout at work, caused by an unhealthy work environment has become imperative. GHRM should become a new philosophy and



culture of human resource management, aimed at retaining and using human resources in the best way, ensuring health at work and well-being of employees [26].

## **CONCLUSION**

Numerous environmental incidents have been reported in the 21st century, including pollution, environmental imbalances, and global warming due to overconsumption of natural resources as basic raw materials in industries [27]. For this reason, organizations around the world are working to implement green human resource management. Increasing environmental awareness has encouraged human resource management to embrace GHRM practices. GHRM should become a new philosophy of human resource management, which aims to develop a sustainable (green, environmentally friendly) organizational culture and use teamwork to manage environmental protection. GHRM practices should implement all human resource management functions. This must include activities such as: designing an organizational structure with centers of responsibility for implementing environmental policy; institutionalization of jobs and positions responsible for environmental issues; setting sustainable goals and developing environmental strategies; developing green skills, knowledge and attitudes of employees; increasing green awareness, etc. [26]. It is generally believed that GHRM provides numerous benefits to companies, such as attracting and retaining employees, reducing operating costs, creating a competitive advantage, improving environmental performance, improving efficiency and sustainable development [13], [28]. In addition, greater environmental awareness provides an opportunity to create new jobs, through the creation of new "green" jobs. However, a large number of organizations still do not see the benefits of green human resource management. Full adoption and integration of this concept requires great effort in order to change the classical human resource management [15]. Further research should aim to develop an effective GHRM model, focused on the environmental and social outcomes of corporate environmental responsibility; identification of mechanisms for the transformation of classical human resource management into green human resource management; development of tools for integration of GHRM into the system of environmental protection in a changing environment; elaboration of methods for evaluation of GHRM practice; creating an empirical basis for assessing the social, economic and environmental results of the implementation of GHRM practice, etc.

## **REFERENCES**

- [1] Chaudhary, R.: Green Human Resource Management and Employee Green Behavior: An Empirical Analysis, *Corporate Social Responsibility and Environmental Management*, Vol. 27, pp. 630-641, 2019.
- [2] Chaudhary, R.: Green human resource management and job pursuit intention: Examining the underlying processes, *Corporate Social Responsibility and Environmental Management*, Vol. 26, pp. 929-937, 2019.
- [3] Shah, M.: Green human resource management: Development of a valid measurement scale, *Business Strategy and the Environment*, Vol. 28, pp. 771-785, 2019.
- [4] Yusliza, M-Y, Norazmi, N. A., Jabbour, C. J. C., Fernando, Y., Fawehinmi, O., Pais Seles, B. M. R.: Top management commitment, corporate social responsibility and green human resource management: A Malaysian study, *Benchmarking: An International Journal*, Vol. 26, No 6, pp. 2051-2078, 2019.
- [5] Jabbar, M.H., Abid, M.: GHRM: Motivating employees towards organizational environmental performance, *MAGNT Research Report*, Vol. 2, No. 4, pp. 267-278, 2014.
- [6] Roscoe, S., Subramanian, N., Jabbour, C. J., Chong, T.: Green human resource management and the enablers of green organisational culture: Enhancing a firm's environmental performance for sustainable development, *Business Strategy and the Environment*, Vol. 28, pp. 737-749, 2019.
- [7] Renwick, D. W., Redman, T., Maguire, S.: Green human resource management: A review and research agenda, *International Journal of Management Review*, Vol. 15, No. 1, pp. 1-14, 2013.

- [8] Ren, S., Tang, G., Jackson, S. E.: Green human resource management research in emergence: A review and future directions, *Asia Pacific Journal of Management*, Vol. 35, No. 3, pp. 769-803, 2018.
- [9] Tang, G., Chen, Y., Jiang, Y., Paille, P., Jia, J.: Green human resource management practices: Scale development and validity, *Asia Pacific Journal of Human Resources*, Vol. 56, No. 1, pp. 31-55, 2018.
- [10] Schuler, R., Jackson, S. E.: Human resource management and organizational effectiveness: yesterday and today, *Journal of Organizational Effectiveness: People and Performance*, Vol. 1, No. 1, pp. 35-55, 2014.
- [11] Zhao, H., Zhou, Q.: Socially responsible human resource management and hotel employee organizational citizenship behavior for the environment: A social cognitive perspective, *International Journal of Hospitality Management*, Vol. 95, 2021.
- [12] Hewagama, G., Boall, P., Cheung, G., Hutchison, A.: Service recovery through empowerment? HRM, employee performance and job satisfaction in hotels, *International Journal of Hospitality Management*, Vol. 81, pp. 73-82, 2019.
- [13] Yong, J.K., Kim, W. G., Choi, H. M., Phetvaroon, K.: The effect of green human resource management on hotel employees' eco-friendly behavior and environmental performance, *International Journal of Hospitality Management*, Vol. 76, pp. 73-83, 2019.
- [14] Gilal, F., Ashraf, Z., Gilal, N. G., Gilal, R. G., Channa, N. A.: Promoting environmental performance through green human resource management practices in higher education institutions: A moderated mediation model, *Corporate Social Responsibility and Environmental Management*, Vol. 26, pp. 1579-1590, 2019.
- [15] Đorđević Boljanović, J., Dobrijević, G., Đoković, F.: Održivost i zeleni menadžment ljudskih resursa, *Ecologica*, Vol. 24, No. 88, 2017.
- [16] Opatha, H. H. D. N. P., Arulrajah, A. A.: Green human resource management: Simplified general reflections, *International Business Research*, Vol. 7, No. 8, pp. 101-112, 2014.
- [17] Masri, H., Jaroon, A. A. M.: Assessing green human resources management practices in Palestinian manufacturing context: An empirical study, *Journal of Cleaner Production*, Vol. 143, pp. 474-489, 2017.
- [18] Acquah, I. S. K., Agyabeng-Mensah, Y., Afum, E.: Examining the link among green human resource management practices, green supply chain management practices and performance, *Benchmarking: An International Journal*, Vol. 28, No 1, pp. 267-290, 2021.
- [19] Amrutha, V. N., Geetha, S. N.: A systematic review on green human resource management: implications for social sustainability, *Journal of Cleaner Production*, Vol. 247, pp. 119-131, 2020.
- [20] Sheopuri, A., Shepuri, A.: Green HR practices in the changing workplace, *Dimensions*, Vol. 2 No. 1, pp. 13-26 2015.
- [21] Guerci, M., Montanari, F., Scapolan, A., Epifanio, A.: Green and nongreen recruitment practices for attracting job applicants: exploring independent and interactive effects, *The International Journal of Human Resource Management*, Vol. 27, pp. 129-150, 2016.
- [22] Renwick, D. W. S., Redman, T., Maguire, S.: Green Human Resource Management: A Review and Research Agenda, *International Journal of Management Reviews*, Vol. 15, pp.1-14, 2013.
- [23] Borojević, T., Vuković, G.: Razvoj „zelenih“ ljudskih resursa, Štedljivo (Lean) upravljanje resursima u privredi Republike Srbije, XI skup privrednika i naučnika SPIN '17, pp. 252-257, Beograd, 2017.
- [24] Jackson, S. E., Schuler, R.S., Jiang, K.: An aspirational framework for strategic human resource management, *The Academy of Management Annals*, Vol. 8, No. 1, pp. 1-56, 2014.
- [25] Tseng, M-L., Chiu, S. F., Siriban-Manalang, A. B.: Sustainable consumption and production for Asia: sustainability through green design and practice, *Journal of Cleaner Production*, Vol. 40, pp. 1-5, 2013.
- [26] Tsymbaliuk, S., Vasylyk, A., Stoliaruk, K.: Green human resource management: how to implement environmental issues into HR practices, *International Conference on Sustainable, Circular Management and Environmental Engineering (ISCMEE 2021)*, Web Conferences 255, 2021.

- [27] Young, J. Y., Yusliza, M-Y., Jabbour, C. J. C., Ahmad, N. H.: Exploratory cases on the interplay between green human resource management and advanced green manufacturing in light of the Ability-MotivationOpportunity theory, *Journal of Management Development*, Vol. 39, No. 1, pp. 31-49, 2020.
- [28] Kim, Y. J., Kim, W. G., Choi, H. M., Phetvaroon, K.: The effect of green human resource management on hotel employees' eco-friendly behavior and environmental performance, *International Journal of Hospitality Management*, Vol. 76, pp. 83-93, 2019.

## CIRCULAR ECONOMY PRINCIPLES IN THE HAZARDOUS WASTE PACKAGING MANAGEMENT

Marko Rokvić<sup>1,2</sup>, Galina Ilinykh<sup>3</sup>, Nemanja Stanisavljević<sup>1</sup>, Maja Sremački<sup>1</sup>,  
Zoran Čepić<sup>1</sup>

<sup>1</sup>University of Novi Sad, Faculty of Technical Sciences, Novi Sad, Serbia,

<sup>2</sup>Green Group, Bačka Palanka, Serbia

<sup>3</sup>Environmental Protection Department, Perm National Research Polytechnic University,  
Komsomolsky prospek 29, Perm, Russia

e-mail: [markorokvic@gmail.com](mailto:markorokvic@gmail.com)

**Abstract:** In Serbia, 7% of total hazardous waste is hazardous waste packaging. This amount of waste is being processed in the waste treatment facilities, or exported to the EU countries, for incineration. This paper aims to give new insight in the problem of waste packaging. Using principles of circular economy on hazardous waste packaging, numerous benefits could be made. First, less hazardous waste will need treatment or export, less need for new packaging, and lower cost for the industry. In this paper, an outline for use of circular economy principles in regards to hazardous waste packaging. Hazardous packaging can be assessed, following the proposed approach given in the paper. After assessment, packaging could be reused or repurposed.

**Key words:** hazardous waste, packaging, circular economy

### INTRODUCTION

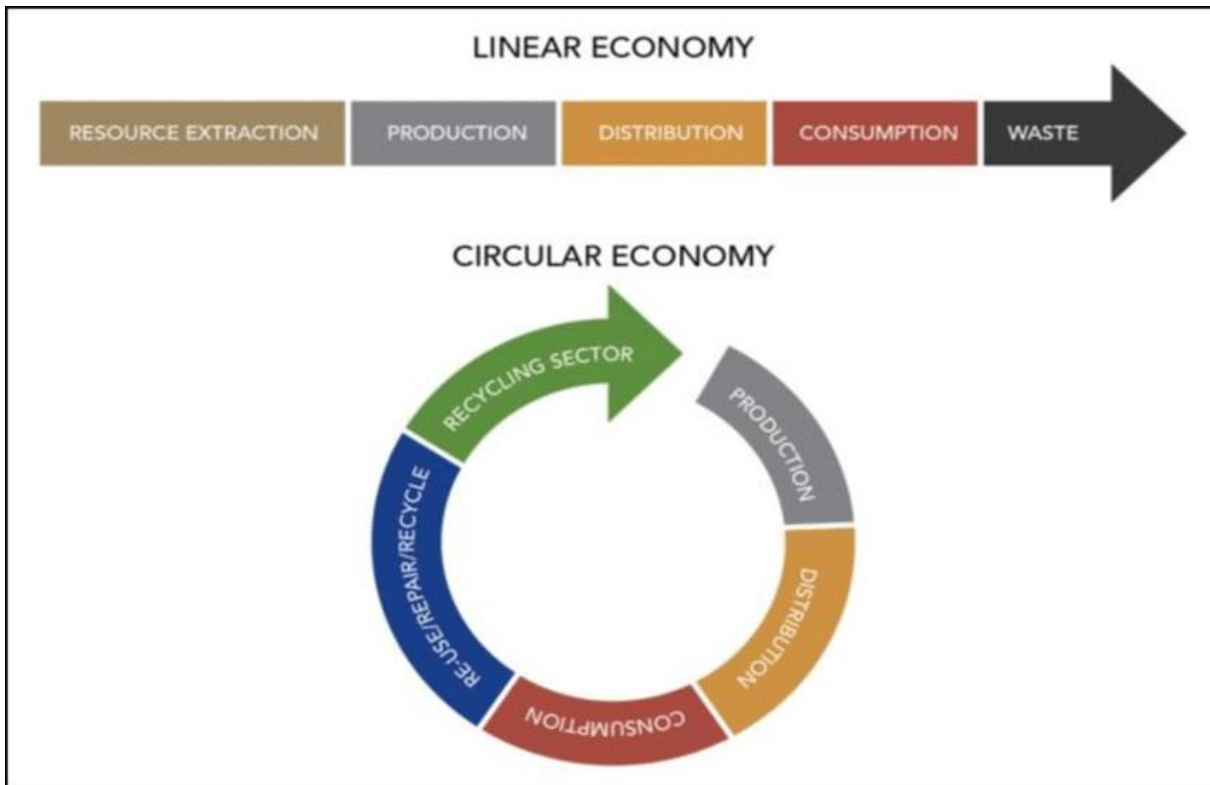
The circular economy (CE) is defined as an economy “where the value of products, materials, and resources is maintained in the economy for as long as possible, and the generation of waste is minimized” [1]. Its objective is to protect industries and consumers from resource scarcity and volatile prices by reducing dependence on primary resources and promoting efficient resource use in a more sustainable way. This concept thus becomes the main solution for tackling the waste crises of various governments and industries around the world. Although CE is a relatively new term, it stems from multiple existing concepts including the well-known 3R principle (reduce, reuse, recycle), regenerative design, the performance economy, cradle-to-cradle, the blue economy, green growth, natural capitalism, biomimicry, industrial ecology, industrial symbiosis studies, ecological and environmental economics. To close the loop between a product’s end of life and its production, an increasing rate of recycling is undeniably the key in driving the transitional process from a linear “take-make-dispose” economy to a circular “make-use-return” economy [2].

Hazardous waste is type of waste that hasn’t been affected by CE principles so far. Due to its possible hazardness, hazardous waste has continued to be treated under the waste legislation. Industry is paying for treatment for their contaminated packaging. There isn’t another mechanism for this type of packaging to be reused, other than treatment. Circular economy should address this issue in the future.

### MATERIAL AND METHODS

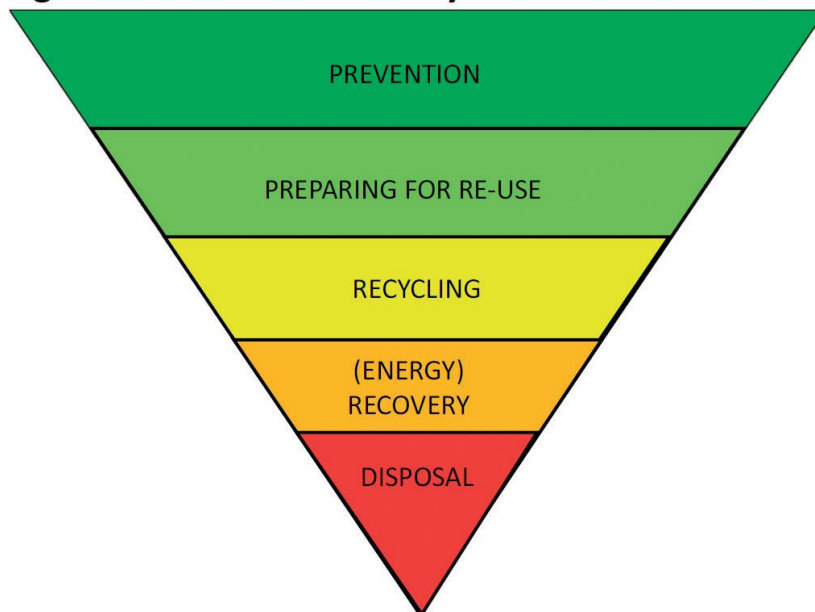
#### Circular economy

The circular economy is often presented in general terms as a transition from a linear (take, make, use, dispose) model to a circular (restorative and regenerative) model. The literature, however, offers no single and ubiquitous definition, but a general consensus on the central concepts and aims of a circular economy. There are two kinds of definitions: those that are resource oriented and focus on the need for closed loops of material flows and reduced consumption of virgin resources; and those that go beyond the management of material resources to incorporate additional dimensions, such as changing models of consumption.



**Fig.1.** The linear economy and the circular economy

A frequently quoted definition by the Ellen MacArthur Foundation (EMF) sees a circular economy as: “one that is restorative and one which aims to maintain the utility of products, components and materials and retain their value”. [3] [4] The EU action plan for the circular economy describes a transition “where the value of products, materials and resources is maintained in the economy for as long as possible, and the generation of waste minimized”. [1] A key focus is thus on minimizing the need for new inputs of materials and energy, and reducing the environmental pressures related to resource extraction, emissions and waste. A guiding principle for the minimization of waste in a circular economy is the waste hierarchy, in which actions to reduce and manage waste are given an order of preference (Fig. 2).



**Fig. 2.** The CE waste hierarchy

In simple terms, the types of processes needed for a transition to a circular economy can be categorized as:

- using fewer primary resources,
- maintaining the highest value of materials and products, and
- changing utilization patterns.

In practice, the actions needed to achieve this transition include:

- recycling;
- efficient use of resources;
- utilization of renewable energy sources;
- remanufacture, refurbishment and reuse of products and components;
- extension of product life;
- product as service;
- sharing of products; and
- waste prevention, including innovations to design out waste in products and a shift in consumption patterns.

Alongside these actions, the phasing down of incineration and landfilling as options for waste management is seen as a requirement, although the best options for dealing with residual waste still need assessment [2].

The concept of the circular economy is often presented, even in the EU action plan, as enabling wider economic and social benefits, such as greater well-being, sustainable growth and employment.

### **Model of circular economy**

As with definitions, models of the circular economy vary in scope and sophistication:

1. preserving and enhancing natural capital by controlling finite stocks and balancing renewable resource flows;
2. optimizing resource yields by circulating products, components and materials at the highest utility;
3. fostering system effectiveness by revealing and designing out negative externalities.

A number of related concepts and associated global and European initiatives are linked with the circular economy concept. The circular economy can be seen as a means of progressing towards sustainable development through achieving the sustainable development goals.

The working definition of a green economy provided by the United Nations Environment Programme (UNEP) is “one that results in improved human well-being and social equity, while significantly reducing environmental risks and ecological scarcities”. Thus, it is interlinked with the circular economy, in particular in its low-carbon approaches and resource efficiency, but has been interpreted as being wider in range, as it includes social and ecosystems dimensions. References to the circular economy in UNEP green economy documents focus mainly waste and the use of materials. The green economy is also closely linked to sustainable development and is seen as a tool for achieving sustainable development in the 2012 Rio+20 agenda.

The circular economy is also closely linked to the concept of initiatives focused on resource efficiency. The EU Resource Efficiency Roadmap (part of the Europe 2020 strategy) outlines the circular economy as an interlinked initiative in terms of sustainable materials management where waste becomes a resource. [5] The EU action plan for the circular economy also links the circular economy to the implementation of global commitments under the Group of 7 (G7) Alliance on Resource Efficiency.

### **Hazardous packaging waste**

Hazardous packaging waste is every piece of packaging contaminated with hazardous material, usually packed in that packaging, packaging of motor oil, various hazardous chemicals, dye, paint etc. It can be made of various materials – plastic, metal, wood. EWC code is 15 01 10\* - packaging containing residues of or contaminated by hazardous substances.

Currently, almost entire amount of hazardous packaging waste goes to treatment, or even export, in case of specific contaminants, re-use is extremely rare. According to Packaging regulation, the distributor of packaging has to either accept used packaging, or to organize packaging to be picked up by waste management company. Generally, the second option is selected, and waste management company collects the packaging, and treat it in required way. Commonly this means cleaning, shredding, and using it for incineration, or, in case of metal packaging, it goes to the foundry. Total amount of hazardous waste, generated in Serbia in 2019 was 78 413 tones. Hazardous packaging is about 7%, or 5 451 tones [6].

There are few steps that need to analysed, when trying to implement circular economy principles:

1. Using the packaging without any treatment. This is the case with oil packaging, specific chemicals, etc. This is the ideal case, e.g. chemicals for waste water treatment can be packaged in IBC containers, and they can be reused numerous times, if they aren't damaged.
2. Reusing packaging after cleaning the residue. In some cases, there are residues in packaging that could be used in production, and before any reuse, the residue was to be removed. The best option is to use the original packaging for the storage of waste material, if possible.
3. If residue cannot be removed without damaging the packaging, packaging needs to be addressed as hazardous waste and treated like such.
4. If residue cannot be removed without damaging the packaging, but it may be used to store other types of hazardous waste, it should be used so. Precaution is necessary in case of possible biochemical reactions.
5. Damaged packaging is not an object of the study, and it has to be treated like regular hazardous waste.

Depending of the type of hazard, it is necessary to make an assessment of potential hazard if using the packaging with residue.

## **RESULTS AND DISCUSSION**

### **Proposed approach**

The paper used as an example the approach given by Silva and Morais [7]. Their approach presented as sharing responsibilities in solid waste management of a Brazilian craft brewery. This approach was basic for development of the approach given in this paper.

Initially, all participants in the process must be identified. To do so, it is recommended that a planning meeting be held in order to clarify the purposes of the process, as well as to verify the decision maker's availability and their interest in participation. There should be representative of the industry sector, being the largest generator of hazardous packaging, environmental ministry, environmental agency, and the waste management sector. There has to be a group formed, for every type of packaging.

In Step 1, a list of all concerns, considerations, and issues that are related to the decision-making process should be drawn up. To do so, several techniques can be used, ranging from informal conversation with people who have faced similar situations to considering the worst and best possibilities that could occur in that scenario.

Step 2 has to be government regulation, incentives, fines and procedures. Industry needs to have a clear view on what are they getting for accepting the CE principles. Waste management sector must be obliged to turn down treatment of packaging, if the packaging fits into first two groups – can be reused.

Due to the fact that this is hazardous waste, returning the packaging to distributor has to be under waste management and ADR regulations.

For reuse of packaging, special procedures must be followed. This is not empty packaging, and has to be treated as such.

Whatever method is used, regulators and waste contractors may require verification that waste packaging has been correctly assessed and handled. Assessments must be reviewed and updated regularly to pick up any relevant changes relating to:

- Material specification
- Supplier

- Substance classification
- Packaging design/weight
- Method of emptying

Therefore, companies need to maintain records of the assessments carried out and any sampling programs used.

According to current waste legislation in Serbia, a recycling facility must report the amount of waste they receive from waste generators as well as the waste generated from their recycling process to officials. Yet, a recycling facility is not required to record or report the quantity of their recycled products or details of their buyers. This loophole allows for the opportunity for a recycling company to dump their waste illegally inside their area instead of recycling it as stated in a permit [8]. This issue is also a threat to CE in hazardous waste, so best possible monitoring is advisable.

## **CONCLUSION**

The proposed approach for group decision was shown to be an important approach in understanding, seeking, and defining reverse logistics actions for proper solid waste management under the circular economy perspective, as the reuse alternative prioritized is one of the means to keep solid waste in the supply chain channel until no more value can be recovered. Moreover, in the proposal the approach does not impose a solution on the DMs for migrating to a circular economy, but presents mean, methods, and tools necessary for reflection for building a collaborative decision-making environment, based on information sharing, on understanding different perspectives and on creating trust between those involved. Thus, the application of the approach in the case study presented can be extended to other companies, as well as to sectorial agreements in other segments, as an alternative way of complying with Law, and also can be implemented in other developing countries that want to make the transition to a circular model.

In addition to the benefits presented by the sustainable development in a circular perspective on implementing the actions, the model had some managerial implications. For the private sector, the reuse of packaging in the production process makes it possible to reduce the purchase of new packaging, assists in the process of integrating and coordinating the direct and reverse flows of operations, thereby improving their management, especially in relation to packaging inventories.

Furthermore, it helps to improve the company's corporate image by the adoption of environmentally friendly actions. The government benefits directly from the reduction of waste collected by the waste management companies.

Lack of governmental support is recognized as one of the main challenges of hazardous waste management in the world; therefore, national and regional authorities need to develop hazardous waste packaging policies and legislation to deal with the growing problem of this waste stream. A transformation to sustainability must also be "just", and so the transition to a CE must be fair and inclusive for workers, firms, and communities for it to be effective. Regional co-operative alliances for an industrial symbiosis or eco-industrial networks will contribute to a robust waste management system. These collaborations could bring several sustainability advantages by minimizing energy and raw materials intake, reducing waste, and foster sustainable relationships. Promoting awareness at all levels, governments, businesses, and the public is key to achieve success in reduce and reuse strategies.

Appropriate plans are required to develop sustainability standards and support practices with low energy consumption and low emissions. Therefore, further research is required to explore sustainable technologies and transportation systems in a hazardous waste packaging. Some limitations should be taken into account when considering the results of this study. The material composition of hazardous waste packaging is highly heterogeneous and may vary in time and space; therefore, the compositions cannot be determined univocally. Moreover, the market value of the secondary resources in packaging may vary as it depends on fluctuating market conditions, the grade of materials, and geographical locations.

This study provides the basis for further cost-benefit or techno-economic analyses of circular economy principles in hazardous waste packaging. In future cost-benefit analysis, the costs of neglecting health and environmental burdens arising from hazardous waste could be included. [9]



This is the first study of its kind about the potential for a reuse of hazardous waste packaging. Regardless of the strong applicability of a CE for various waste streams, hazardous waste has been neglected in previous studies. The sensitivity analyses highlight that the response to the hazardous waste packaging challenge must be timely to be able to convert the recovery and reuse potential into an opportunity. Each year of inaction would not only result in economic losses but also amplify environmental and health costs. However, achieving the highest level of material recovery and closing the material loop can only be reached through collaborative and long-term efforts at multiple scales.

## **REFERENCES**

- [1] Closing the loop - An EU action plan for the Circular Economy, European Commission, 2015
- [2] Sharma H.B., Vanapalli K.R., Samal B. et al.: Circular economy approach in solid waste management system to achieve UN-SDGs: Solutions for post-COVID recovery, *Science of the Total Environment* 800 (2021) 149605, 2021.
- [3] Towards a circular economy: business rationale for an accelerated transition. Cowes: Ellen MacArthur Foundation, 2015.
- [4] Circular economy in Europe: developing the knowledge base, European Environment Agency Report No 2/2016, European Environment Agency, Copenhagen, 2016
- [5] Roadmap to a resource efficient Europe. Communication from the Commission to the European Parliament, The Council, The European Economic and Social Committee and The Committee of the Regions, European Commission, Brussels, 2011
- [6] "Waste management in the Republic of Serbia in the period 2011-2019. years", Environmental Protection Agency of Republic of Serbia, State report, 2019.
- [7] Silva W., Morais D.: "Transitioning to a circular economy in developing countries: A collaborative approach for sharing responsibilities in solid waste management of a Brazilian craft brewery", *Journal of Cleaner Production* 319 (2021) 128703, 2021.
- [8] Otwong A., Jongmeewasin S., Phenrat T.: Legal obstacles for the circular economy in Thailand: Illegal dumping of recyclable hazardous industrial waste, *Journal of Cleaner Production* 302 (2021) 126969, 2021.
- [9] Hunt A., Dale N., George F: Circular Economy and health: opportunity and risks, WHO Regional Office for Europe, Copenhagen, 2018.

## THE ROLE OF TYPE II ENVIRONMENTAL LABELS IN CIRCULAR PACKAGING

Milana Ilić Mićunović<sup>1</sup>, Tamara Novaković<sup>1</sup>, Zoran Čepić<sup>1</sup>, Boris Agarski<sup>1</sup>,  
Zorica Miroslavljević<sup>1</sup>

<sup>1</sup>University of Novi Sad, Faculty of Technical Sciences, Novi Sad, Serbia

e-mail: [milanai@uns.ac.rs](mailto:milanai@uns.ac.rs)

**Abstract:** Circular economy model is increasingly accepted in the most developed economies and world largest companies. At the same time eco-labeling is a tool for achieving some of these goals. This paper contain the basics of the concept and principles of circular economics. Also, circular packaging is defined and the possibilities offered by the circular economy in the packaging sector are pointed out. An overview of circular packaging models and different contribution of eco-labeling to the circular packaging system is given. The role of eco-labeling in the circular economy is defined with examples of the connection between eco-labels type II (Mobius loop, recycling codes, environmental claims, Green Dot) with circular economy. Research of the market of the Republic of Serbia has be done, where data were obtained on the extent to which the eco-label in the service of the circular economy is on the products. The results showed that recycling codes and the Mobius loop are the most common eco-labels in the service of circular economy on products. It can be concluded from the paper that eco-labeling represents a significant support to the circular economy, with some aspects that should be solve.

**Key words:** eco-labeling, circular economy, circular packaging

### INTRODUCTION

The current production model, linear, is based on the transformation of resources into finished products and their disposal (conversion into waste) after use. This model has never been sustainable, but today, with the achieved levels of utilization of natural resources and the achieved level of pollution of the planet, its application is limited in time from both practical and economic aspects. Depletion of available natural resources, growing world population, level of environmental pollution, operational problems of large cities in waste disposal, etc., are problems that society has been facing for many years, but technological advances only in recent years have allowed consideration of implementing an alternative approach circular economies [1]. Endangering the environment as an environmental problem has become not only current but also vital [2].

In the last few decades, a model of "circular economy" has been developing, which with its principles of functioning and essence tries to replace the model of linear economy and in the future to prevent further deterioration not only in the exploitation of non-renewable natural resources but also to prevent further environmental endangerment. The basic principle of this model is that as much as is technologically possible today, waste materials, either from the production process or from the waste of finished processing products, are recycled, i.e., subjected to treatment, and to re-enter the production process in a new form. In this way, the irrational consumption of natural resources would be suppressed, significantly better environmental protection would be provided, and input factors of production (materials) would be significantly cheaper.

An eco-label is defined as a label given to products that are considered to be less harmful to the environment than other products in the same category [3]. One of the important indirect instruments in environmental protection, on a global level today, is certainly environmental labeling. The mechanism of action of this instrument can, in short, be explained as follows: a label on a product/service that shows that the product/service is less harmful to the environment should, on the one hand, motivate an environmentally conscious consumer to buy it, while growth consumption of such products should, on the other hand, motivate producers to develop and produce more suitable products from the environmental aspect.

The aim of this work was to determine the role of type II eco-labels in the circular economy and circular packaging system. Also, research of the Republic of Serbia market, on 100 products was conducted, with the results of the distribution of eco-labels on different product categories.

## CIRCULAR ECONOMY

The circular economy is an approach that transforms the function of resources in the economy. Waste from the production process becomes a valuable raw material in another production process, and the products themselves can be repaired, reused or improved, instead of being discarded. It is based on the maximum utilization of the used resources, i.e. that the product, instead of being discarded before the full utilization of value, is used again and again [4].

Circular economy is a regenerative economic system in which the environment is taken into account, natural resources are saved, and the amount of waste for disposal is reduced. In production processes, attention is paid to energy consumption and emphasis is placed on the use of renewable energy sources [5]. Fig. 1a shows the concept of circular economy.

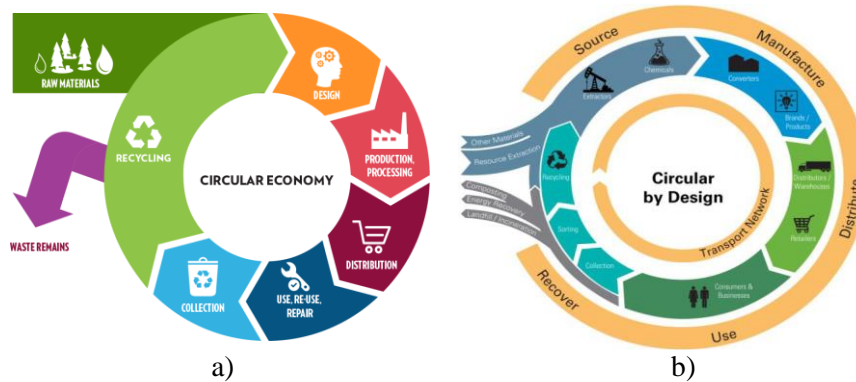


Fig. 1.: a) Concept of circular economy [6]; b) circular vision of packaging [7]

On the road to a circular economy, recycling is a leading instrument. Recycling is the process of separating material from waste and reusing it for the same or similar purposes. The process includes the collection, separation, processing and production of new products from used items and materials. It is important to sort waste by type, because many waste materials can be reused if they are collected separately. Anything that can be reused, not thrown away, is recycling. Eco-labeling in this regard can contribute to this system.

## CIRCULAR PACKAGING

Packaging plays a key role in the modern way of life. Without it, most products would break down or be damaged before they reach the store. However, it is often cited as one of the main problems in our planet's battle for environmental sustainability, as it turns into waste after each use. Therefore, companies from different industries are looking for a way to close the circle and reduce the negative impact of packaging on the environment, while still using its positive properties [8].

The biggest problem with packaging is that it usually becomes waste as soon as the customer finishes using the product. That's why smart packaging experts focus on creating a design that is optimized for recycling. By making existing packaging easier to recycle - and by using more and more recycled materials in new packaging - companies can help keep materials in the value chain longer.

This idea is at the heart of the circular economy model: a way of thinking that seeks to collect materials after they are used and to process them so that they can be reused and recycled again. In this way, waste is eliminated and the impact of packaging on the environment is reduced - as long as there are good systems for recycling and waste management [9].

Design is a key principle of the circular economy (Fig.1 1b).

## TYPE II ENVIRONMENTAL LABELING

The ISO 14021 standard defines Type II environmental labeling as self-declaring environmental claims. These can be statements, labels or symbols that refer to a specific activity, product or service of the manufacturer that may have an impact on the environment. This type of eco-label refers to only one specific property of the selected product.

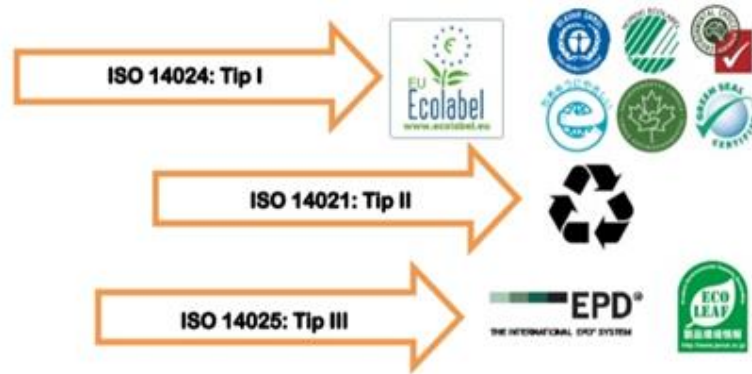


Fig. 2. Different types of environmental labeling

This type of eco-label can be found on the product or on the product packaging, in product documentation, technical inspection, advertisements and promotions, or through electronic or digital media and is issued by the manufacturer, importer, distributor, seller or any other person who may benefit from such publication [10]. Type II eco-labels do not include the procedure of independent certification by a third party, and the awarding of such eco-labels does not take into account the impact of product properties on the environment throughout the product life cycle.

## ECO-LABELS AND CIRCULAR ECONOMY

### Mobius loop

The Mobius loop contains three connected arrows in the shape of a triangle with rounded corners (Fig. 3a). Each arrow is folded back and all three are connected to each other, which conditionally represents the recycling cycle. The Mobius loop is a symbol for the three R environments [11]:

- Reduce
- Re-use and
- Recycle.

The Mobius loop is in line with the circular economy, which is also based on three "R" principles and which unequivocally illustrates the strong links between the environment and the economy. These principles represent a circular system through which materials are recycled, energy is obtained from renewable sources, renewable resources are in the function of creating new value, and a very important effect is the restoration of ecosystems [2].

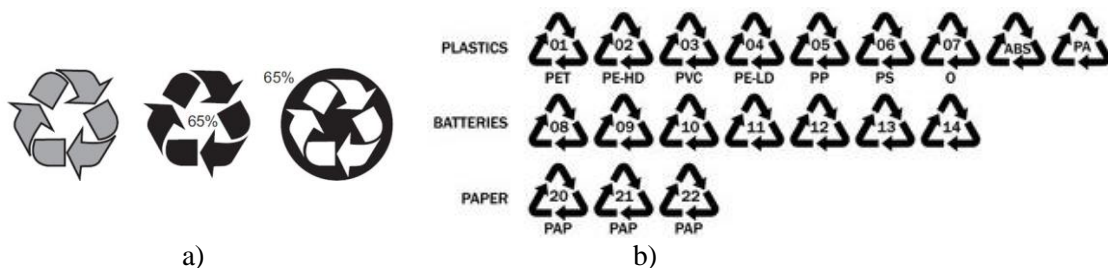


Fig. 3.: a) Mobius loop [10]; b) Recycling codes [14]

Reduce - reuse - recycle are the basic postulates of total waste management, primarily on the effort to avoid waste, i.e. reduce its quantities, then to reuse it, then recycle and process, giving new usable products, and only finally what is unusable and will be disposed of in a way that will not be harmful to the environment and human health [12]. In this way, it contributes to the goals of the circular economy, which strives to extend the "life" of the product and return all waste material to the production process. This achieves efficient use of resources, reduction of environmental pollution, while achieving financial savings and creating new business opportunities to make the waste of one industry a raw material for another industry [13].

## Recycling code

The Mobius loop eco-label was included in the catalog of ISO 7000 standards in 1984, and since 1997 the European Commission has proposed the addition of alphanumeric labels, which are used today. The principle is very simple: below the sign there is a letter abbreviation of the material from which the packaging is made, while inside the loop there is a numerical mark [14] (Fig. 3b).

The mission in the circular economy is to reduce waste to zero (zero-waste), ie a world in which waste is not created is the ultimate goal. Recycling is the process of collecting and processing materials that would otherwise be thrown in the trash, with the goal of creating a new product. In that sense, recycling codes help to separate waste at the place of origin, i.e. sorting by type of waste because only separately collected waste can be used (primary selection) [15].

## Green Dot

By joining the "Green Dot" program, producers are deprived of the obligation to take back their packaging waste. The green dot is assigned to the packaging, not the product itself. While smart packaging design directly contributes to customers' environmental goals. For example, it reduces the CO2 footprint through reduced material use and better recycling [16].



Fig. 7. Green Dot in circular model [16]

The Green Dot symbol supports a circular model that involves a circular process - waste becomes a resource that can be reused. Instead of ending up in a landfill, packaging waste is returned to store shelves, in some other form.

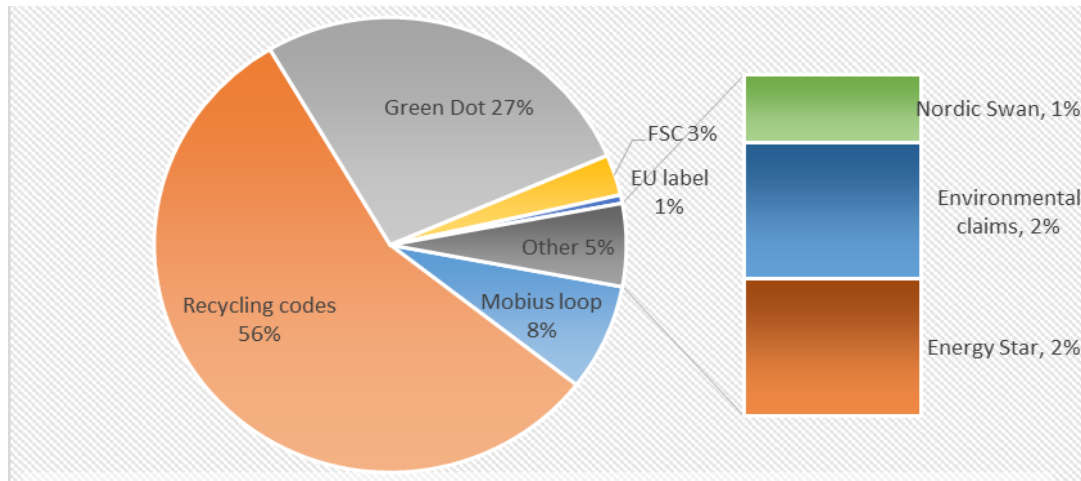
## Environmental claims

An environmental claim is an attitude, symbol or graphic that indicates an environmental aspect of a product, its component or packaging. The environmental claim can be on product or packaging labels, in product documentation, in technical journals, advertisements, media, telemarketing, as well as in digital or electronic media such as the Internet [10].

The selected terms that are most often used as self-declaring claims and defined in ISO 14021 standard. Claims that support for the circular economy are: compostable, degradable, designed for disassembling, extended life product, recovered energy, recyclable, recycled content, reduced energy consumption, reduced resource use, reduced water consumption, reusable and refillable, waste reduction, renewable material, renewable energy, sustainable, claims relating to greenhouse gas emissions.

## MARKET RESEARCH AND RESULTS

Based on the research obtained data, expressed as a percentage, of how much a certain eco-label in the service of the circular economy is represented per 100 researched products. The most common eco-labels on the researched products are recycling codes with 56% and Green Dot with 27%. Less present eco-labels on these products are the Mobius loop, FSC, EU eco-label, Nordic swan, environmental claims and energy star (Fig. 5).

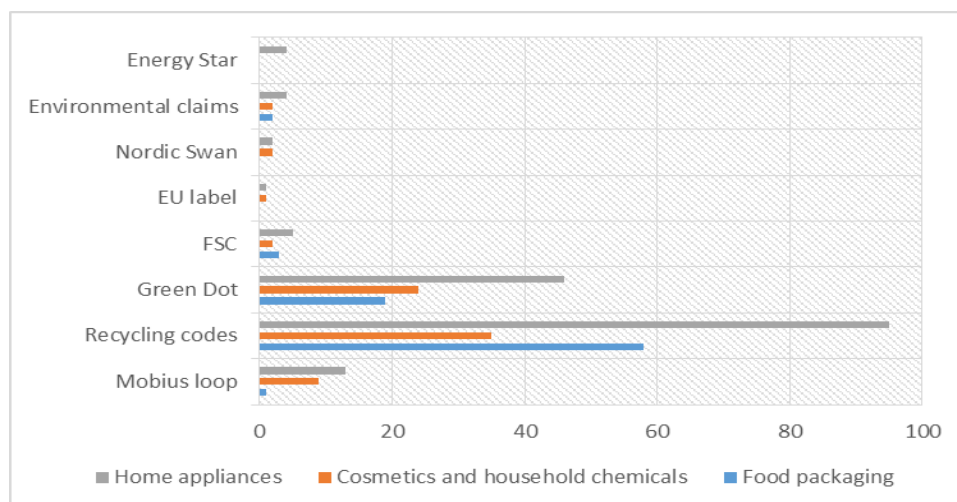


**Fig. 8.** Distribution of eco-labels in the service of circular economy (%) for selected 100 products

The results of the research show that the most common eco labels in the service of circular economy on food packaging are recycling codes (58) and Green Dot (19). These products contain a much smaller number of FSC eco-labels, the Mobius loop and environmental claims.

In the category of household chemicals and cosmetics, the most common eco-labels in the circular economy service are recycling codes (35), Green Dot (24) and Mobius loop (9). These products are less represented by the FSC label, the EU eco-label, the Nordic swan and environmental claims.

On white goods and home appliances, the most common labels in the circular economy service are Energy Star (4), Mobius loop (3), Green dot (3) and recycling codes (2) (Fig. 9).



**Fig. 9.** Distribution of eco-labels by product categories

## CONCLUSION

The conducted research provided insight into labels that are in the service of the circular economy and packaging present on market of the Republic of Serbia. The research showed that most common environmental label on products are recycling codes and Green Dot, and to a lesser extent, the Mobius

loop, FSC, the EU eco-label, the Nordic Swan, environmental claims and the energy star are present. It is necessary to design recyclable and reusable products, as well as energy-saving products, use wood from controlled sources, reduce the use of resources, energy and water in the production of products, etc. In this way, the products contribute to a positive impact on the environment and meet the goals of the circular economy.

Eco-labels can influence shopping behavior, but the problem is that consumers very often are not aware of the label or do not have knowledge about it. It is necessary to educate consumers, bring them closer to the concept and meaning of eco-labels, and in that way encourage them to think about preserving our planet. Campaigns can be conducted to increase the recognition and knowledge of eco-labels. The impact of eco-labels on the environment is difficult to assess, so there is limited evidence of their impact on the environment and further research is needed to show the contribution to the results of the circular economy.

## REFERENCES

- [1] European Commission: Closing the Loop - an EU Action Plan for the Circular Economy. Communication from the Commission to the European Parliament, the Council, the European Economic and Social Committee and the Committee of the Regions, 2015.
- [2] European Commission: Behavioural Study on Consumers' Engagement in the Circular Economy - Final Report. Directorate-General for Justice and Consumers, Brussels, 2018.
- [3] Ellen MacArthur Foundation: Towards the Circular Economy Opportunities for the Consumer Goods Sector, 2013.
- [4] Ewert, B.: Moving beyond the obsession with nudging individual behaviour: towards a broader understanding of behavioural public policy, *Publ. Pol. Adm.* 35 (3), 337e360, 2020.
- [5] Corona, B., Shen, L., Reike, D., Rosales Carreon, J., Worrell, E.: Towards sustainable development through the circular economy-a review and critical assessment on current circularity metrics, *Resour. Conserv. Recycl.*, 151, pp.104498, 2019.
- [6] <https://srip-circular-economy.eu/>, 20.09.2021.
- [7] [https://www.lazardassetmanagement.com/us/en\\_us/references/fundamental-focus/packaging-in-the-circular-economy](https://www.lazardassetmanagement.com/us/en_us/references/fundamental-focus/packaging-in-the-circular-economy) 20.09.2021.
- [8] Gluščević, M, Kaluđerović, Lj.: Analiza kapaciteta jedinica lokalne samouprave u pogledu stvaranja uslova za prelazak na cirkularnu ekonomiju, Beograd: Deutsche Gesellschaft für Internationale Zusammenarbeit (GIZ) GmbH, 2019.
- [9] Rex, E., Baumann, H.: Beyond ecolabels: what green marketing can learn from conventional marketing, *J. Clean. Prod.*, 15 (6), pp. 567-576, 2007.
- [10] ISO 14021:2016 Environmental labels and declarations — Self-declared environmental claims (Type II environmental labelling)
- [11] Yokessa, M., Murette, S.: A review of eco-labels and their economic impact, *Int. Rev. Environ. Resour. Econ.*, 13 (1-2), pp.119-163, 2019.
- [12] Budak, I., Vukelic, Dj., Agarski, A., Ilić Mićunović, M.: Life cycle design and assessment tools, University of Novi Sad, Faculty of technical sciences, Novi Sad, 2020.
- [13] Ziółkowski B., Agarski B., Sebo J. (ed.): Innovations in circular economy - environmental labels and declarations, Publishing House of Rzeszow University of Technology, e-ISBN 978-83-7934-456-7, 2021.
- [14] Meis-Harris Julia, Klemm Celine, Kaufman S, Curtis J, Borg Kim, Bragge P.: What is the role of eco-labels for a circular economy? A rapid review of the literature, *J. Clean. Prod.*, 306, pp.1-16, 2021.
- [15] Marrucci, L., Daddi, T., Iraldo, F.: The integration of circular economy with sustainable consumption and production tools: systematic review and future research agenda, *J. Clean. Prod.* 240, pp.118268, 2019.
- [16] <https://sekopak.com/cirkularna-ekonomija-i-reciklaza/>, 20.09.2021.

Session 8:  
**Occupational Safety**



## DECISION ANALYSIS AND APPLICATION OF THE DELPHI METHOD IN THE SELECTION OF EMPLOYEE EDUCATION IN THE FORMATION OF THE INVESTMENT PROJECT

<sup>1</sup>Aleksandra Kovačević

<sup>1</sup>University of Novi Sad, Technical Faculty "Mihajlo Pupin", Zrenjanin, Serbia

e-mail: [aleksandra.unija@gmail.com](mailto:aleksandra.unija@gmail.com)

**Abstract:** Modern society is based on modern technology, knowledge and new management theories. The application of new technologies has greatly helped to improve the quality of human action in many areas. Companies are increasingly attaching importance to quality. In order to fully achieve the quality system, it is necessary to clearly and precisely define the goals and strategies by which the company is run. The adoption of new knowledge and skills, as well as the use of new ideas, represent a pillar of modern economic trends. The paper uses two methods of analysis, one analysis includes decision-making analysis in which it was necessary to decide for the year that is most profitable for the organization of the seminar. The second method referred to the Delphi method, which needed to determine in which year the number of injuries at work would be reduced if part of the investment plan included seminars for employees who would later become certified persons in these areas. The paper is formed on the basis of a concrete example from the company. As the business expands in the area that brings potential risk, it is necessary to increase security measures, installation of furnace baking systems in retail outlets.

**Key words** safety and health at work, quality control, efficiency, analysis, delphi method, injuries at work, knowledge, human resources

### INTRODUCTION

The focus is on internal employee training. Employee education becomes an integral part of the management organization. Knowledge management is a significant source of competitive strength of organizations, from which derive numerous business benefits. It should also be borne in mind that most knowledge is specific. Knowledge is usually created for a specific use [1]. In other words, certain knowledge is valuable only in certain situations at a certain time. This fact can be related to the stretching to be the first and at the same time the best in the field of one's activity. Therefore, it does not make much sense to include it in a specific segment of the knowledge management system, because it would be irrelevant for most people outside a certain unit or if it does not perform a certain function. There is no unanimity as to which areas belong to applied mathematics. Historically, applied mathematics consisted mainly of applied analysis, primarily of differential equations, approximations, theories, asymptotic methods, variational methods, and numerical analysis and probability. These areas of mathematics were intimately linked to the development of Newton's physics. Until the early 20th century, topics such as classical mechanics were often taught in applied mathematics departments at American universities, rather than in physics departments. Physics, engineering and computer science have traditionally used applied mathematics. Today, the term applied mathematics is used in a broader sense. It includes classic areas as well as other areas that have become increasingly important in applications. Even areas such as number theory, which are part of pure mathematics, are now important in applications (such as cryptography), although they are generally not considered part of the field of applied mathematics per se. Sometimes the term applied mathematics is used to distinguish between traditional applied mathematics developed in addition to physics, and many areas of mathematics that can be applied in the real world. Knowledge management is currently considered a key factor for organizational development, enterprise competitiveness, and productivity improvement.

### INVESTMENT PROJECT OF EXPANSION OF BUSINESS SEGMENT IN RETAIL FACILITIES

There are different types of investments in a company's business. In this case, it includes and includes the investment plan for the realization of the investment project education of employees in the field of

health and safety at work with the aim of expanding a certain segment in business. Specifically, the project refers to expanding the business segment in retail facilities.

The company plans to expand one segment of its business. The plan is to install bakery systems in retail outlets. Given the nature of the work, the company plans to include in this project the organization of seminars, training of additional education related to the protection of safety and health of employees. The trend is that companies are constantly innovating in their business processes, so retail chains are introducing various innovations into their business. One of them is the introduction of bakeries in retail facilities.

If viewed from a personal angle from the individual standpoint, overall success will be achieved both at the state level and at other higher levels. Businesses need to operate within their industry. Only in that way will the complete health of the workers be preserved, and thus the health of the entire population. The goal of such a project is to raise awareness among all employees about the importance of health and to take all necessary safety measures. The security measures that are applied in companies depend on the early place, on the area of operation of the company, on the organizational structure. Occupational safety measures belong to the application of protection against various factors that affect the health of employees. Factors that affect the health of employees are poor lighting, high noise of machines, a large amount of dust produced by machines during production processes. It can also be largely a human factor. Poor training of employees, insufficient expertise can cause injuries at random. Due to all the above, it is necessary to educate employees and help them in this way to increase safety at work. A healthy team is the foundation for successful market positioning.

The project is planned to be implemented once a year for five years, and a certain number of employees will be certified for the application of safety and security measures at work. After certification, they will be able to offer their services to other companies.

The current situation present in companies is:

- Small number of educations,
- Low budget for employee education,
- Weakened economy
- And all these factors are directly related to the low standard of living,

So with all the above, the idea is to improve all these segments through this project.

The investment study refers to the situation when a company invests, either in existing or completely new areas. Its purpose is precisely to make an analysis and to assess the justification or feasibility of a particular investment.

## **ANALYSIS OF DECISION SELECTION OF SEMINARS WHEN FORMING AN INVESTMENT PROJECT**

Decision analysis without a priori probabilities refers to situations when the decision maker is not able to assign appropriate probabilities to certain situations. A priori probability decision analysis is applied to select the optimal action in multi-action problems, where it is necessary to determine the quantity of a product to be procured in advance. An important feature of this group of problems is that the number of alternatives is always equal to the number of possible conditions in the problem [1].

The company plans to expand one segment of its business. The plan is to install bakery systems in retail outlets. Given the nature of the work, the company plans to include in this project the organization of seminars, training of additional education related to the protection of safety and health of employees. The trend is that companies are constantly innovating in their business processes, so retail chains are introducing various innovations into their business. One of them is the introduction of bakeries in retail facilities.

Companies in this case cannot predict the demand for these services, but based on experience, they estimate that there will be a greater need in the market to provide this type of service. With the introduction of additional training for employees, it is estimated that safety in the workplace will

increase to a higher level. In this regard, companies are implementing within the project of employee education. After completing the seminars, trainings, the employees will be tested, after which they will receive a certificate of passed training in relation to the level they showed in the testing. In this way, this group of employees becomes certified by a certain certification house. After that, it will be able to provide training services to other companies that are also engaged in the production and distribution of bakery products.

The company's plan is to organize 50-70 seminars a year in the field of health and safety at work. The company set aside 25,000 for each employee for certification.

***(T) = 25,000 RSD***

Certified employees will offer their services to other companies at a price of 35,000 RSD for the certification of one employee.

***(C) = 35000 RSD***

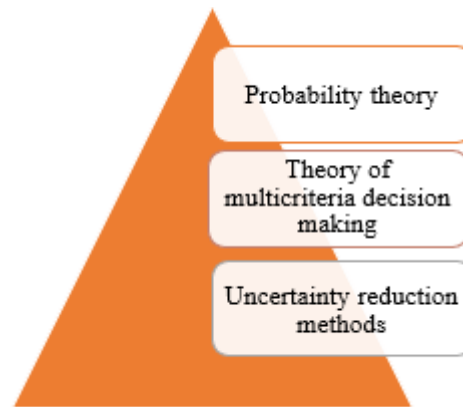
During the year, certified persons in this case, employees offer their services with a discount of 15% in the summer when the demand for these services is lower, which will amount to 30,000 RSD. The company plans to organize seminars during the annual level in the interval of 55-70 seminars

### **ANALYSIS OF DECISION SELECTION OF SEMINARS WHEN FORMING AN INVESTMENT PROJECT**

Decision analysis without a priori probabilities refers to situations when the decision maker is not able to assign appropriate probabilities to certain situations. A priori probability decision analysis is applied to select the optimal action in multi-action problems, where it is necessary to determine the quantity of a product to be procured in advance. An important feature of this group of problems is that the number of the company plans to expand one segment of its business. The plan is to install bakery systems in retail outlets. Given the nature of the work, the company plans to include in this project the organization of seminars, training of additional education related to the protection of safety and health of employees. The trend is that companies are constantly innovating in their business processes, so retail chains are introducing various innovations into their business. One of them is the introduction of bakeries in retail facilities.

Companies in this case cannot predict the demand for these services, but based on experience, they estimate that there will be a greater need in the market to provide this type of service. With the introduction of additional training for employees, it is estimated that safety in the workplace will increase to a higher level. In this regard, companies are implementing within the project of employee education. After completing the seminars, trainings, the employees will be tested, after which they will receive a certificate of passed training in relation to the level they showed in the testing. In this way, this group of employees becomes certified by a certain certification house. After that, it will be able to provide training services to other companies that are also engaged in the production and distribution of bakery products.

The company's plan is to organize 50-70 seminars a year in the field of health and safety at work. The company set aside 25,000 for each employee for certification.



**Fig. 1.** Quantitative models of decision making

**The decision-making process requires:**

Identifying decision problems The beginning of the decision process. The problem of decision-making exists when a goal is set to be achieved and when a situation is present that contains two or more alternative actions to achieve that goal. Defining the decision-making problem In order to clearly define the decision-making problem, it is necessary to fully understand the set goals that are to be achieved. Decisions are made in order to achieve the set goals, so they must be clearly defined. In addition, it is necessary to establish which factors create difficulties in a given situation and what should be corrected and changed. Perception of possible states of affairs - uncertain events The occurrence of a certain consequence of some of the alternative actions depends on the possible state of affairs (whose occurrence is uncertain). In order to evaluate and compare alternative actions with regard to these consequences, it is necessary to consider some possible states of affairs, is anticipate future conditions that would have an impact on the consequences of the action taken [2].

Consideration of possible outcomes (consequences) and evaluation of their value. One of the basic conditions for comparing alternative actions is to consider the possible outcomes (consequences) of these actions and to assess their value (usefulness) with regard to the goals for the purpose of which the choice between alternative actions is made.

Choice of decision criteria. When deciding in conditions of uncertainty, the decision maker usually adopts some of the decision criteria, ie. rule for choosing one of the alternative actions. It is in fact the choice of the appropriate strategy that the decision maker uses in the evaluation of alternative actions and the choice of one of them based on the results of that evaluation [2].

Evaluation of alternative actions. After determining the possible state of affairs, as well as the possible consequences of alternative actions, when the values of these consequences are assessed and after the appropriate strategy is selected based on which the evaluation of alternative actions will be performed, it is possible to estimate the expected values of each available alternative actions .Making a decision based on the obtained estimates of the expected values of each of the alternative shares, the choice of shares is made (decision making) in accordance with the adopted rules of selection, is criteriadecision making.

Performing the selected action, evaluating the effects and correcting the last stage in the decision-making process consists in performing the selected action. After that, it is necessary to collect information on the effects of the selected action, evaluate the values of these effects with regard to the set goals and make the necessary corrections in order to achieve the goals as efficiently and completely as possible, for which the decision-making process began. Sometimes it is necessary to decide on the necessary corrections [3] .

**Structuring decision problems involves defining:**

Alternative decisions that can be made, uncertain outcome as a result, criteria by which the value of various combinations of decisions and outcomes is assessed, ways of presenting problems.

Decision alternatives are a choice that must be made by the decision maker. For each situation, the manager must make a list of possible options. Setting feasible alternatives may involve some selection (perhaps using an optimization model). Making the final decision involves many qualitative factors. Managers must be sure to consider all possible options. This often requires considerable creativity to define even those options that are most often not considered. Managers cannot irrationally carry out the process of finding solutions to consider creative alternatives. Finally, it is necessary to define the final outcome.

Another task in the structure of the decision problem is to define the outcomes that can occur once the decision is made. These outcomes provide the basis for assessing the risks associated with the decision. Outcomes can be qualitative and quantitative in nature. Outcomes related to decisions are often called states of nature to emphasize the fact that the decision maker has no control over them.

Decision criteria

Decision makers must have well-defined criteria by which to evaluate potential options. The decision-making criteria must be such as to achieve maximum profit or social benefit or to reduce costs to a minimum [4].

### DELFI METHOD AS PART OF THE INVESTMENT PLAN

The Delphi method is based on statistical processing of collected opinions obtained from experts for certain areas and is one of the effective techniques to encourage creativity [5].

When forming the investment plan and defining the investment, it is necessary to follow all the parameters that are important for the investment itself. Every investment is a significant step for business. The Delphi method is a very flexible method, but a method that requires arbitrary opinions of other people, is specific experts. If the right experts are not selected and competent enough when choosing a certain decision, problems can arise.

The Delphi method, as one of the qualitative research methods within the positivist and constructivist paradigm, is structured as a process of group communication. It studies phenomena that are difficult to quantify and for which it is not possible to report objective statistical laws [6].

The investment plan, which includes an investment in the installation of bakery systems in retail outlets, aims to improve the retail network. The business policy of the company is to always have a healthy team. A healthy team is the path to successful business. Reducing injuries at work is of strategic importance to the company. In this regard, it is necessary to conduct education related to safety at work and thus in part improve business and on the other hand preserve a healthy team. In this way, the company will enter the market guided by the strategy of being the first and at the same time the best [7].

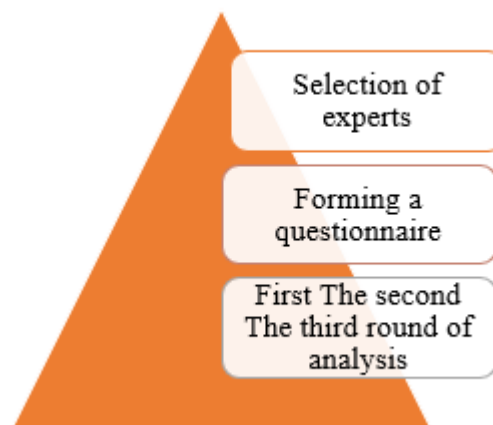


Fig. 2. Steps in applying the delphi method

During the Delphi method, we first need to create a specific questionnaire with the specific data we need. After creating the questionnaires are distributed to experts who bring some of their opinions on a given problem [8]. After which the analysis and calculations are approached. In a concrete example, the company plans the realization of an investment project, the realization of which will reduce the number of injuries at work.

In this case, the goal is to determine in which year of business the number of injuries at work will be reduced by 30% if seminars are organized before the expansion of the business segment. In order to get the answer, questions were asked to the experts, in this case the answers were given by 5 experts: Out of a total of 5 experts.

Each of the experts gave their opinion. Opinions could be:

- Optimistic: o
- Pessimistic: p
- Possible: m

**Table 1.** Expected value for each expert

Year	2022	2023	2024	2025	2026	2027	2028
Experts	0	1	2	3	4	5	6
1			m				
2	p			m			
3		o	m	p			
4				o	M		p
5		o		m		P	

### Pert method

The Perth method was developed for the need of planning, time control, project activities. This method is extremely important for project management, in fact the management of investment projects and all activities that require a certain amount of time during implementation.

*t* represents the individual time given by each expert

When applied in the formula, it is observed in which year which answer was given on the basis of the expert's answer, a calculation is made. The pert method is a network planning method that determines the duration of a project.

$$t_i = \frac{r_1 \cdot o_i + r_2 \cdot m_i + r_3 \cdot p_i}{r_1 + r_2 + r_3} \tag{1}$$

$$r_1 = 1 ; r_2 = 4 ; r_3 = 1$$

$$t_1 = 2$$

$$t_2 = \frac{1 \cdot 2 + 4 \cdot 1 + 1 \cdot 0}{1 + 4 + 1} = \frac{2 + 4 + 0}{6} = 1$$

$$t_3 = \frac{1 \cdot 1 + 4 \cdot 2 + 1 \cdot 3}{1 + 4 + 1} = \frac{1 + 8 + 3}{6} = 2$$

$$t_4 = \frac{1 \cdot 3 + 4 \cdot 4 + 1 \cdot 6}{1 + 4 + 1} = \frac{3 + 16 + 6}{6} = 4,167$$

$$t_5 = \frac{1 \cdot 1 + 4 \cdot 3 + 1 \cdot 5}{1 + 4 + 1} = \frac{1 + 12 + 5}{6} = 3$$

1. According to the answers given by expert number 1, it is expected that the number of injuries at work will be reduced by 30% in the second year of the project.
2. According to the answers given by the expert number 2, the year in which the number of injuries at work will be reduced by 30% will be in the first year of the project.
3. According to the answers given by the expert number 3, the year in which the number of injuries at work will be reduced by 30% will be the second year of the project.
4. According to the answers given by the expert number 4, the year in which the number of injuries at work will be reduced will be 4 years of project implementation.
5. The fifth expert answered that 3 years in which injuries at work will be reduced by 30%

In this part, a calculation is made according to the opinion given by each expert separately. Because of this, this method is considered to be one of the most unreliable. For the reason that any expert can give a subjective opinion or an opinion based on assumptions.

**Total expected value:**

$$t_n = \frac{1}{n} \cdot \sum_{i=1}^n t_i \quad (2)$$

$$t_n = \frac{1}{5} \cdot (2 + 1 + 2 + 4,167 + 3) = 0,2 \cdot 12,167 = 2,43 \text{ year}$$

*n number of experts and the sum of all expert answers*

The total expected value is the number of years that are considered to achieve a reduction of injuries at work by 30% with the organization of seminars in this case is the range of 2-3 years but it is more likely that this expectation will be realized in the second year of the project

**Dispersion for each expert:**

Represents the mean square deviation from the arithmetic mean

$$\delta_i^2 = \frac{(p_i - o_i)^2}{r_n} \quad ; \quad r_n = 36 \quad (3)$$

$$\delta_1^2 = 0$$

$$\delta_2^2 = \frac{(0 - 2)^2}{36} = -0,11$$

$$\delta_3^2 = \frac{(3 - 1)^2}{36} = 0,11$$

$$\delta_4^2 = \frac{(6 - 3)^2}{36} = 0,25$$

$$\delta_5^2 = \frac{(5 - 1)^2}{36} = 0,44$$

**Total dispersion**

$$\delta_n^2 = \frac{1}{n} \left[ \sum_{i=1}^k \delta_i^2 + \sum_{i=1}^n (t_i - t_n)^2 \right] \quad (4)$$

$$\delta_n^2 = \frac{1}{5} [(0 - 0,11 + 0,11 + 0,25 + 0,44) + (2 - 2,43)^2 + (1 - 2,43)^2 + (2 - 2,43)^2 + (4,17 - 2,43)^2 + (3 - 2,43)^2]$$

$$\delta_n^2 = \frac{1}{5} (0,69 + 0,18 + 2,04 + 0,18 + 3,03 + 0,32) = 0,2 \cdot 6,44 = 1,29$$

**Table 2.** Total dispersion

	Time	$y = \frac{t_i - t_n}{\delta_n}$	P = probability
2022	0	-1,88	0,03
2023	1	-1,11	0,134
2024	2	-0,33	0,371
2025	3	0,44	0,67
2026	4	1,22	0,889
2027	5	1,99	0,977
2028	6	2,77	0,997

$y = \frac{t_i - t_n}{\delta_n}$  y represents the probability of the event (5)

$$y = \frac{0 - 2,43}{1,29} = -1,88$$

$$y = \frac{1 - 2,43}{1,29} = -1,11$$

$$y = \frac{2 - 2,43}{1,29} = -0,33$$

$$y = \frac{3 - 2,43}{1,29} = 0,44$$

$$y = \frac{4 - 2,43}{1,29} = 1,22$$

$$y = \frac{5 - 2,43}{1,29} = 1,99$$

$$y = \frac{6 - 2,43}{1,29} = 2,77$$

$Y > 0 \quad P = 0,5 + \Phi(Y)$



$$Y < 0 \quad P = 1 - (0,5 + \Phi(Y))$$

$$P_{2022} = 1 - (0,5 + \Phi(1,88)) = 1 - (0,5 + 0,4700) = 1 - 0,97 = 0,03$$

$$P_{2023} = 1 - (0,5 + \Phi(1,11)) = 1 - (0,5 + 0,3665) = 1 - 0,8665 = 0,134$$

$$P_{2024} = 1 - (0,5 + \Phi(0,33)) = 1 - (0,5 + 0,1295) = 1 - 0,6295 = 0,371$$

$$P_{2025} = 0,5 + \Phi(0,44) = 0,5 + 0,1700 = 0,67$$

$$P_{2026} = 0,5 + \Phi(1,22) = 0,5 + 0,3890 = 0,889$$

$$P_{2027} = 0,5 + \Phi(1,99) = 0,5 + 0,4765 = 0,977$$

$$P_{2028} = 0,5 + \Phi(2,77) = 0,5 + 0,4970 = 0,997$$

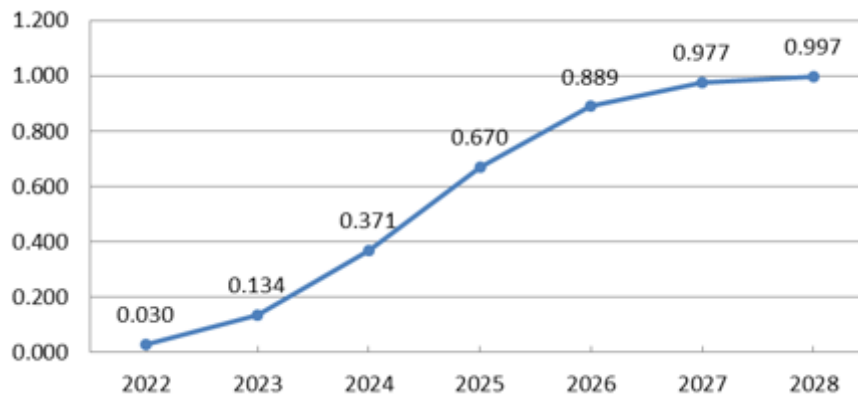


Fig. 3. Probability of events in relation to years

Probability relating to each year individually that the number of injuries at work will be reduced by 30%. The probability account for each year of the project is shown above.

## CONCLUSION

The preparation of the paper included the application of the Delphi method where the company, is specifically the chain of retail facilities, expands one segment of its business. Given that this segment refers to the increased risk of injuries at work, the idea is to determine in which year of the project the number of injuries at work will be reduced. Increased investment in quality education of employees will increase the value of the company. The method of decision-making in conditions of uncertainty belongs to the group where the highest degree of uncertainty is present. This group of methods is the most uncertain for choosing a strategic decision. When choosing, due to bias or personal experience, a decision can be made that is not the most favorable in practice, although when implemented in theory, this method seems to be.

The idea of the work is the realization of a project where companies will expand the segment of their business into their retail facilities. The paper specifically referred to the expansion in the part of installing bakery systems. Before the installation and installation of these systems, taking into account the nature of work and the possibility of injuries at work, employees will attend seminars and trainings for five years once a year in real conditions. After these trainings, employees take certain tests, after which they become certified persons who can also organize and hold seminars.

It is necessary to define the viability of the project before each investment. The extent to which its application is effective. There is an increasing need for the introduction of a management system related to the application of protective measures at work while monitoring the health of employees. The paper applies the methods of statistical data processing through Excel, the part also included decision analysis and the Delphi method on a specific example

## REFERENCES

- [1] Ahmed, P. K., Lim, K.K., Loh, A.Y.E.: Learning through Knowledge Management, Oxford: Butterworth-Heinemann, 2002
- [2] Kočiš, L.: Praktična primena statističkih metoda i alata pri odlučivanju u poslovnom okruženju., Univerzitetski centar za primenjenu statistiku u Novom Sadu, Novi Sad, 2019
- [3] Milić, M.: Odlučivanje i poslovna inteligencija, Banja Luka, 2014
- [4] Nikolić, M.: Metode odlučivanja, Univerzitet u Novom Sadu, Tehnički fakultet “Mihajlo Pupin” u Zrenjaninu., Zrenjanin, 2013
- [5] Echeverry, C., Eduardo, M., Herera, O., Mauricio, B., Vealz, A., Paolo, C.: Knowledge management from the organizational culture in call centers in Manizales. vol.35, n.63, pp.15-25. ISSN 0120-4645, 2019
- [6] Kianto, A., Vanhala, M., Heilmann, P.: The impact of knowledge management on job satisfaction. Journal of Knowledge Management, 20(4), 621–636. [220] Kim, D.H. (1993). The Link Between Individual and Organization, 2016
- [7] Garavalia, L., Gredler, L.: Teaching Evaluation through Modeling: Using the Delphi Technique to Assess Problems in Academic Programs. American Journal of Evaluation, 25(3), 375-380., 2004
- [8] Amos, T., Pearse, N.: Pragmatic Research Design: an Illustration of the Use of the Delphi Technique. Electronic Journal Of Business Research Methods, 6(2),95-102, 2008.

## STRENGTHENING THE CAPACITIES OF OSH IN THE DEFENSE AND SECURITY TRADE UNION (SOB) IN THE REPUBLIC OF NORTH MACEDONIA

Monika Lutovska<sup>1</sup>, Vladimir Mijakovski<sup>2</sup>

<sup>1</sup>Faculty of Technical Sciences, "Mother Teresa" University, Skopje, North Macedonia,

<sup>2</sup>Faculty of Technical Sciences, University "St. Kliment Ohridski", Bitola, North Macedonia

e-mail: [monika.lutovska@unt.edu.mk](mailto:monika.lutovska@unt.edu.mk)

**Abstract:** The main objective of this study is to present the current situation of OSH in the Defense and Security Trade Union (SOB) of the Republic of North Macedonia (RNM), and to point out serious problems that undermine the basic concept of protection of the employee at his workplace. In order to collect the necessary data, an anonymous survey was conducted and educational trainings in the field of safety at work were realized during 2020/2021 for the members of SOB, as the main target group. Also, trainings for future trainers from the ranks of presidents in SOB were conducted, which will enable a process of continuous education on OSH.

From the processing of data in individual anonymous questionnaires, it could be concluded that although only 13% of respondents had any work-related injuries (fractures, bruises, clavicle injuries and other physical injuries), as many as 53% believe that the safety of the employee, even if it is completely protected from physical injury is not enough, so that 22% of SOB members feel unsafe in their workplace.

The most important benefit was that the members of SOB started to think about the value of human life, the importance of their own safety at work, but also for the safety of colleagues, to ask questions and seek answers, but also to give suggestions for their own vision for solving of the existing problems in the field of OSH. However, the biggest benefit of the survey is that 97% of the members of the SOB are of the opinion that nothing can compensate for the loss of a lost human life.

**Key words:** occupational safety and health, personal protective equipment, workplace

### INTRODUCTION

Occupational safety and health incidents occurring in the military context are of great concern to every society, [1]. Military activities are often considered more dangerous than civilian work, especially in crisis situations, but on the other hand, peacetime have seldom been analyzed in this respect, [2]. Incidents such as dangerous incidents, exposures, and near misses, indicate serious safety and health risks faced by military personnel. These risks, even if they do not cause immediate harm, may give rise to harm in the future, if not adequately addressed. In some cases, they may cause latent harm, [1]. While dangerous incidents and exposures cause latent harm, which due to their latency is not recognized as occupational injury or illness, near misses did not expose any person to an immediate risk or result in serious injuries, [3].

In this regard, the dangerous incidents are defined by the Australian Department of Defense as incidents that have exposed the worker or any other person to a serious risk to their health or safety, and emanating from an immediate exposure, or an uncontrolled release of a hazards such as explosions, electrical shocks, collapsed structures, or interruption of air supply, [3]. Usually, officers, cadets, conscripts, and reservists that are trained for military operations, have physically more demanding work than the other groups. In particular, because of military exercises imply high occupational risk, military trainers and trainees are considered to be high-risk groups in the military, [2].

Internationally, statistics on military occupational accidents and diseases are modest. So, the U.S. Department of Defense had reported 10067 injuries/illnesses and 4,185 lost time cases in a population of 230945 employees in 2000 year, which represents an incidence rate of 43.6 cases per 1000 persons (equal to 73 cases per 1 million work hours), [4]. Also, Swedish statistics give an incidence rate of 16.7 occupational accidents and diseases per 1000 gainfully employed persons in its armed forces (equal to 28 cases per 1 million work hours), [5]. Retrospective analyzes of operations in Iraq and Afghanistan that processed data reported by veterans showed that as many as 94% of veterans were at risk of being exposed to extreme external influences during their deployment, including dust storms, smoke from burning trash, oil fires, vehicle exhaust, chemicals and exposure to petrochemical fuels, [6].

In the past decade, according to data from relevant institutions in the Republic of North Macedonia (RNM), in an average population of 732452 employees, an average incidence rate for fatal accidents at work of 4.31, and an average injury incidence rate of 15.24, were registered, [7] (Table 1). The reported accidents and injuries in the defense sector in the same decade are shown in the table below:

**Table.1** Reported accidents and injuries in the Defense sector in RNM.

	Public administration, Police and Defense										
	Year										
	2010	2011	2012	2013	2014	2015	2016	2017	2018	2019	2020
Total number of accidents	26	26	45	9	47	94	46	35	31	24	35
Fatal accidents	0	2	0	0	5	11	0	1	2	3	0

The data in the table indicate that 2015 is the year with the highest number of accidents, but also the largest number of fatal accidents at work that occurred in the Defense sector during the entire decade. The purpose of this study was to present the current situation of OSH in the SOB of the RNM, and to point out serious problems (inadequate personal protective equipment, untimely replacement, insufficient level of hygiene in the working and sanitary facilities, insufficient motivation for work, inadequate or insufficient education and professional development), which undermine the basic concept of protection of the employee at his workplace.

## **MATERIAL AND METHODS**

Although legislative action is essential to promote better working conditions, other instruments are also required to monitor progress and to make sure that objectives have been attained. In this respect, statistical indicators have been developed to enable a more detailed analysis of the causes and circumstances of accidents at work so as to implement targeted preventive measures. [8]. While traditional safety management approaches concentrate on how accidents happen or “something went wrong”, modern safety management tools present a successful methodology designed to deal with uncertainty in high-risk work environment and focuses primarily on the working safety, which encompasses how people adjust and perform in expected or unexpected working conditions, [9].

Trainings, workshops and an anonymous survey, which were part of the implementation of a project from the ILO Program, funded by the EU [10], were used to collect data for this paper. The project involved the members of SOB, so that in the field of OSH were organized and conducted multiple trainings during 2020/2021 in: Regional Basic Organizations (RBO) Crisis Management Center, RBO Veles and Prilep, RBO Kumanovo, RBO Ilinden, RBO 8043 and RBO TRC, with a total of 97 people present (men 76, women 21). The members of the SOB were pointed out the basic rights and obligations in the field of OSH, but also all the hazards in the workplace - severe mechanical injuries, physical and mental loads, stress due to work with weapons, airborne or contact exposures to chemicals or heat arising from fires, exposure to radioactive radiation or electromagnetic waves, problems with personal protective equipment at work or lack thereof, and a number of other factors that definitely put this profile in the rank of high-risk jobs.

In this direction, the survey described a number of job risks, including:

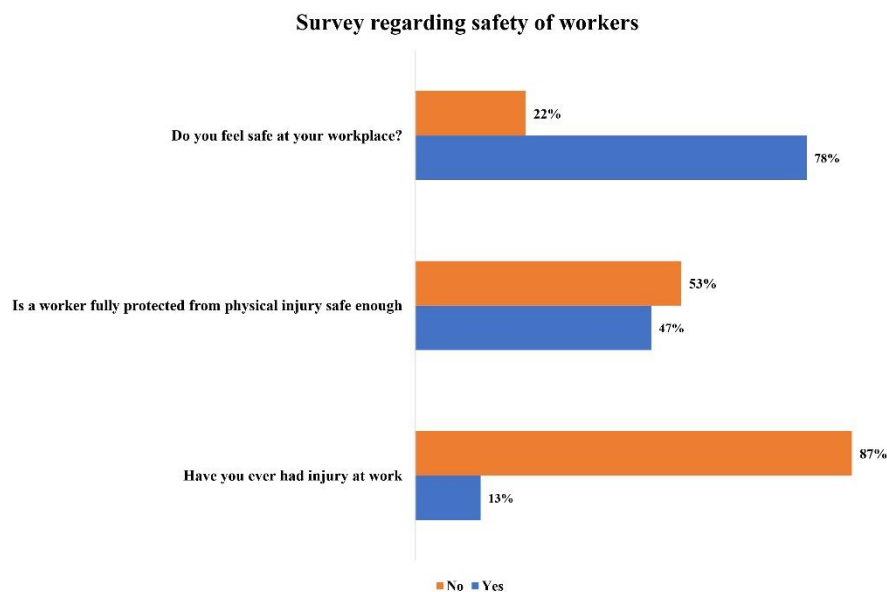
- Injury during handling of weapons and contact with mine explosives
- outdated technology and vehicles;
- defective motor vehicles;
- hearing, vision impairment;
- mechanical injuries to the limbs;
- skin diseases and diseases of the respiratory organs;
- contact with carcinogens;

- handling hoists and cranes that are not regularly inspected and serviced;
- work at height;
- dangers when diving and hiking;
- inadequate microclimatic conditions - non-air-conditioned rooms;
- unfavorable weather conditions in the field - large temperature differences;
- dangers of detonation when destroying ammunition;
- loss of life.

For all these risks, the members of SOB offered proposed measures to reduce the risks, procurement of new and better equipment for personal protection at work, new uniforms, improvement of working conditions, renewal of the vehicle fleet, provision of necessary medicines, regular educational training and staff training, as well as increased controls on elders in order to prevent mobbing in the workplace.

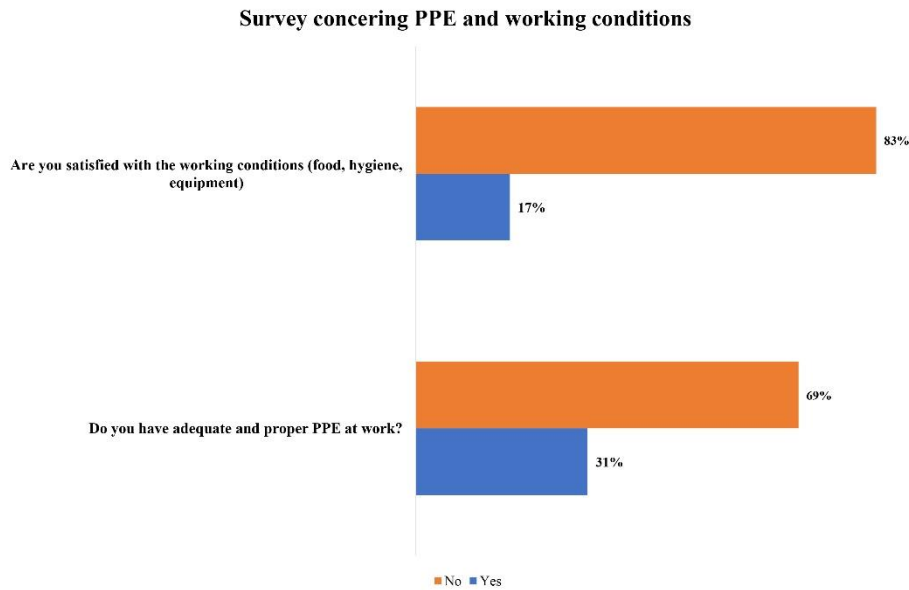
## RESULTS AND DISCUSSION

It could be concluded from the processing of data in individual and anonymous questionnaires, that although only 13% of respondents had any work-related injuries (fractures, bruises, collarbone injuries and other physical injuries), as many as 53% believe that the safety of the worker which even if fully protected from physical injury is not enough, so that 22% of SOB members feel unsafe in their workplace (Figure 1).



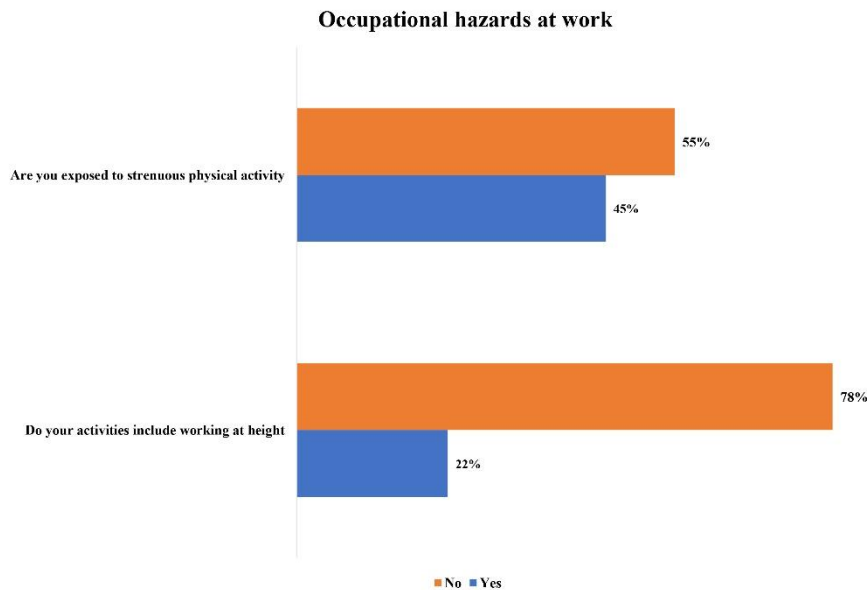
**Fig. 1.** Survey conducted among the members of SOB 2020/2021

Also, one of the biggest problems is the personal protective equipment (PPE) at work, for which 69% stated that it is inadequate and not in good condition, and 83% are not satisfied with the working conditions (sanitary and hygienic conditions, living quarters, diet), (Figure 2).



**Fig. 2.** Survey conducted among the members of SOB 2020/2021

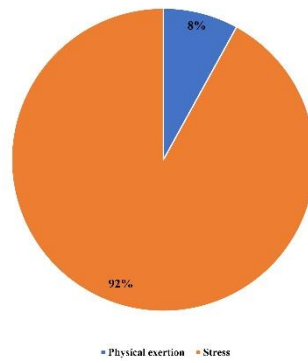
When it comes to occupational hazards, about 22% of respondents are exposed to high-altitude work, 45% to extreme physical activity (Figure 3), 57% do not feel adequately protected from noise when handling weapons, and 42% are people who have experienced an explosion and fire, or were part of a fire and evacuation team.



**Fig. 3.** Survey conducted among the members of SOB 2020/2021

A serious problem is that 92% of the respondents explained that a much bigger problem than physical exertion is the stress they are exposed to, primarily due to the handling of weapons, but also partly due to the present mobbing of superiors for which 32% reported (Figure 4).

Which poses a greater danger to your health?



Have you ever encountered mobbing in your workplace

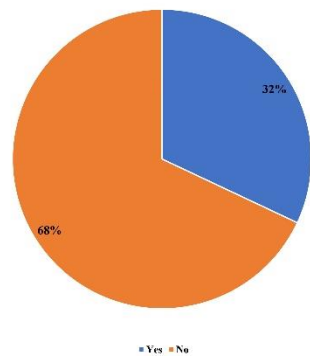


Fig. 4. Survey conducted among the members of SOB 2020/2021

There are 13% of people who come into contact with chemical hazards during operation (asbestos, tear gas, gunpowder particles, battery acid, explosives) and 28% who are exposed to some type of radiation (ultraviolet, radioactive, electromagnetic radiation) (Figure 5), while 13% have acquired an occupational disease due to exposure to the danger for a long period of time.

Survey regarding chemical and radiation exposure

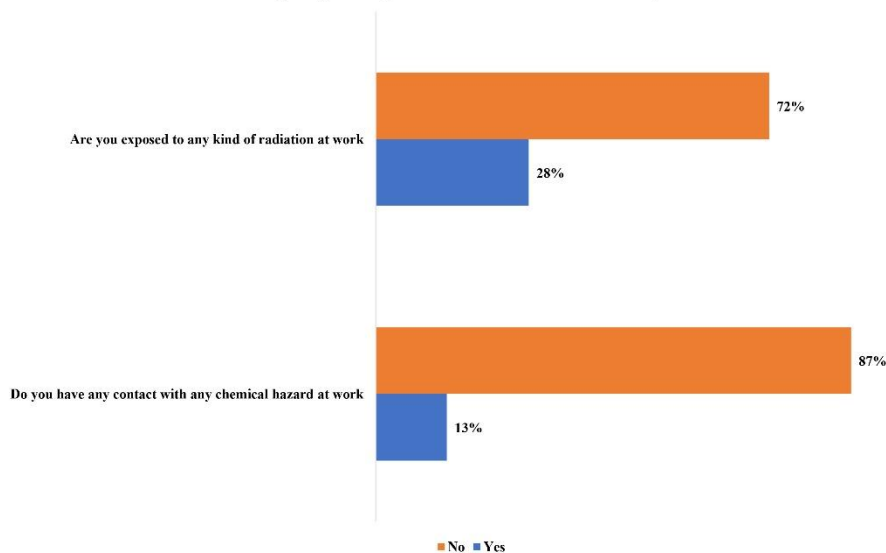


Fig. 5. Survey conducted among the members of SOB 2020/2021

However, the biggest benefit of the survey is that 97% of SOB members (Figure 6), are of the opinion that nothing can compensate for the loss of human life. Furthermore, 95% believe that there is always

an opportunity to improve safety and better care for their own health and the health of colleagues, and 85% would like to improve and upgrade their expertise for the same reason (Figure 6).

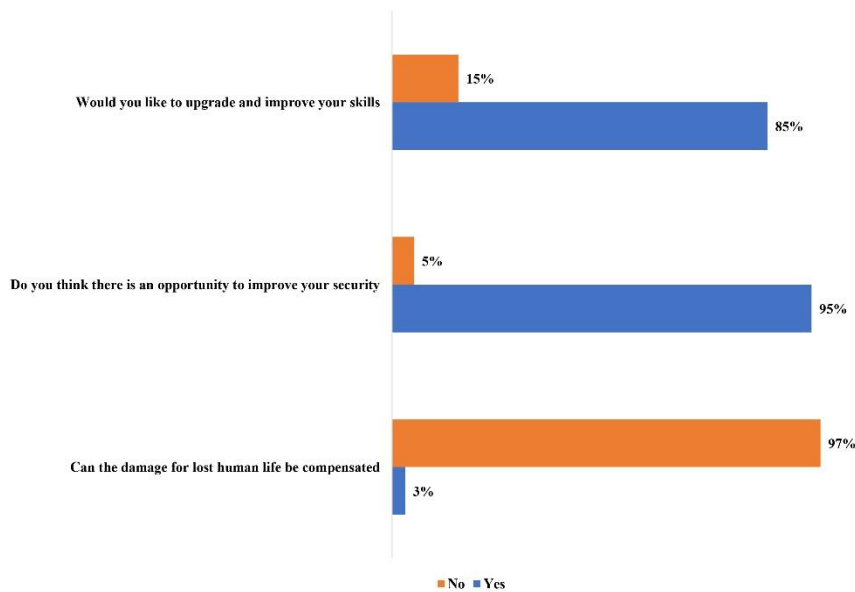


Fig. 6. Survey conducted among the members of SOB 2020/2021

The main benefit of the survey was that the main goal was achieved: workers began to think about the value of human life, the importance of their safety at work and the safety of colleagues, asked questions and sought answers, but also made suggestions for their own vision for solving existing.

## CONCLUSIONS

The importance of healthy workplace and working environment is a crucial factor, so improving working conditions and providing safe and healthy working environment is an essential part of the work quality, equally prompted by humanitarian as well as economic considerations. Modern societies require a critical examination of OSH management quality and it is estimated that well planned and systematically carried out OSH measures, deliver economic returns 3-10 times greater than the monetary investment. However, OSH does not mean only protection of the employee from physical injuries and occupational diseases, but, considered as a multidisciplinary concept it should also be concentrated on the promotion of safety, health and welfare of people engaged in work or employment. So, developing a strong culture of safety and health in our country should be achieved by having engaged leadership working with a committed workforce toward the goal of zero injuries, illness and incidents.

The findings of this study can usefully inform development of risk mitigation strategies for dangerous incidents, exposures, and near misses in army personnel. The occupational requirements of military personnel during training and operations include intense combat training, vigorous manual handling, patrolling and direct combat, and these job requirements can expose personnel to extremely dangerous situations and incidents. Many of the respondents think that the safety of the employee is not enough and they feel unsafe in their workplace pointing out serious problems (inadequate personal protective equipment, untimely replacement, insufficient level of hygiene in the working and sanitary facilities, insufficient motivation for work, inadequate or insufficient education and professional development), that undermine the basic concept of protection of the employee at his workplace.

They also consider that it is necessary to procure new and better-quality equipment for personal protection at work, new uniforms, improvement of working conditions, renewal of the vehicle fleet, provision of necessary medicines, regular training and improvement of the staff, as well as intensified controls on elders in order to prevent mobbing in the workplace. A serious problem is that most of the respondents explained that the stress they are exposed to is a much bigger problem than physical exertion. However, it is clear to everyone that nothing can compensate for the loss of human life, and that education and training are of great importance to every employee.



In 2020, RNM became the 30th member of NATO, so the cooperation of the Ministry of Defense and the Army of RNM with NATO, regarding the Program for the Advancement of Defense Education, began to be implemented and is focused on the priorities in the development of military education.

## ACKNOWLEDGMENT

The research presented in this article had been funded by EU.

## REFERENCES

- [1] Schram, B., Orr, R., Rigby, T., Pope, R., An Analysis of Reported Dangerous Incidents, Exposures, and Near Misses amongst Army Soldiers, *International Journal of Environmental Research and Public Health*, doi: 10.3390/ijerph15081605, 15(8), 1605, 2018.
- [2] Lehtomaäki, K., Paäläkönen, R., Kalliomäki, V., Rantanen, J., Risk of Accidents and Occupational Diseases among the Finnish Defence Forces, *Military Medicine*, 170, 9:756, 2005.
- [3] Australian Government Department of Defence Work Health and Safety Event Severity and Definition, (accessed on 30 August 2021), Available online: <http://www.defence.gov.au/whs/incident-reporting/event-severity-definition.asp>.
- [4] Department of Defense: Army Annual Occupational Safety and Health Program Report: 110 Army Pentagon, Washington DC, 20310-0110. Feb. 2005.
- [5] Nordin H., Bengtsson B., Occupational Accidents and Work-Related Diseases in Sweden, Stockholm, Sweden, Swedish Work Environment Authority, 2001.
- [6] Falvo M.J., Osinubi O.Y., Sotolongo A.M., Helmer D.A. Airborne hazards exposure and respiratory health of Iraq and Afghanistan veterans. *Epidemiol. Rev.* doi: 10.1093/epirev/mxu009, 37, pp.116–130, 2015.
- [7] Annual Reports for fatalities, injuries and accidents at work 2010-2020, Macedonian Occupational Safety and Health Association.
- [8] Causes and Circumstances of Accidents at Work in the EU, European Commission. Directorate-General for Employment, Social Affairs and Equal Opportunities, ISBN 978-92-79-11806-7, 2009.
- [9] Lutovska, M., Mijakovski, V., Muca, A., Identification of Occupational Hazards in Contemporary Working Environment, *South East European Journal of Sustainable Development – SEEJSD (2021)*, ISSN (print) 2545-4463; Vol 5 (2), pp. 107-116, 2020.
- [10] Strengthening the Occupational Safety and Health capacities in the Union of Defense and Security – Strengthening social dialogue, International Labour Organization, International Labor Organization (ILO) project funded by the EU, Program: Act 3.2.3. IA Trade Union of Defense and Security – SOB, 2020.

## STATISTICAL INDICATORS FOR ACCIDENTS AT WORK IN CONSTRUCTION SECTOR

Cvetanka Mitrevska<sup>1</sup>, Elena Mitrevska<sup>2</sup>, Vangelce Mitrevski<sup>3</sup>

<sup>1</sup>International Slavic University Gavriilo Romanovic Derzavin,  
Faculty for Safety Engineering, Sveti Nikole

<sup>2</sup>PHI Health Care Center D-r Haim Abranavel, Bitola

<sup>3</sup>University St.Kliment Ohridski, Faculty of Technical Sciences, Bitola  
e-mail: [vangelce.mitrevski@uklo.edu.mk](mailto:vangelce.mitrevski@uklo.edu.mk)

**Abstract:** In this paper the statistical indicators concerning non-fatal and fatal accidents at work in the European Union (EU-28) and in the Republic of North Macedonia from 2012 to 2018 in construction sector were presented. The performed statistical analysis shows that the number of non-fatal and fatal accidents at work in EU-28 in 2018 was decreased in comparison with 2012. In the Republic of North Macedonia in 2018 there was an increase in the number of non-fatal and fatal accidents at work in construction sector in comparison to the number of accidents at work in 2012. Nevertheless, in the Republic North of Macedonia the value of incidence rate for fatal accidents at work in construction sector in 2018 is much lower compared to the average value in EU-28.

**Key words:** construction sector, non-fatal accidents, fatal accidents, incidence rate.

### INTRODUCTION

Construction is one of the most risk activities in terms of accidents at work. Construction workers are exposed to a number of accidents at work, especially serious and fatal injuries, which is a sufficient cause for concern for the tripartite stakeholders of the International Labor Organization (ILO). Despite the existence of law of safety at work, accidents at work in this activity are increasing every year. Increasing the quality of safety at work and health of employees in construction sector, and in the workplace in general, should be the primary goal of every employer. Given the difficult working conditions, as well as the hazards and harmfulness at faced by construction workers, relevant activities should be taken by project holders, contractors, supervisors and all parties involved, for successful completion of project. The process of building and constructing facilities includes activities on temporary and mobile construction sites that include the flow of materials, workers as well as machinery and mechanical equipment. The workers on the construction site work in difficult and dynamic conditions.

A complete classification of the hazards and harmfulness of a mobile construction site is given by Ferrett, [3]:

- hazards when working at height,
- hazards during excavation,
- hazards during demolition,
- hazards due to the movement of vehicles (internal transport),
- hazards when using equipment on a construction site,
- dangers of electricity,
- fire hazards,
- chemical and biological harmfulness, and
- physical hazards and mental health hazards.

In this paper, some statistical indicators for non-fatal and fatal accidents at work in construction sector in the European Union and in the Republic of North Macedonia were presented.

## MATERIAL AND METHODS

In this paper two main types of statistical indicators on accidents at work in construction activity are used: number of non-fatal and fatal accidents at work and incidence rate. The databases of Eurostat for the values of the number of accidents at work (non-fatal or fatal) in the EU-28 were used, while for the Republic of North Macedonia data from relevant institutions were used. For the calculation of the values of the incidence rate the methodology of the European Statistics on Accidents at Work (ESAW) was used [1].

## RESULTS AND DISCUSSION

### Statistical indicators for non-fatal and fatal accidents at work in the European Union

In construction sector in 2018 there were over 385249 non-fatal accidents that resulted in at least four calendar days of absence from work and 716 fatal accidents (Table 1) [3]. In the total number of non-fatal accidents at work in the EU-28 between 2012 and 2018 there was decrease for 423000 accidents i.e. equivalent to a decrease of 8.61 % (Fig.1). During on 2018, in the Member State on EU-28 there were 153 fatal accidents at work fewer when compared with 2012 i.e. equivalent to on decrease of 21.37 % (Fig.2).

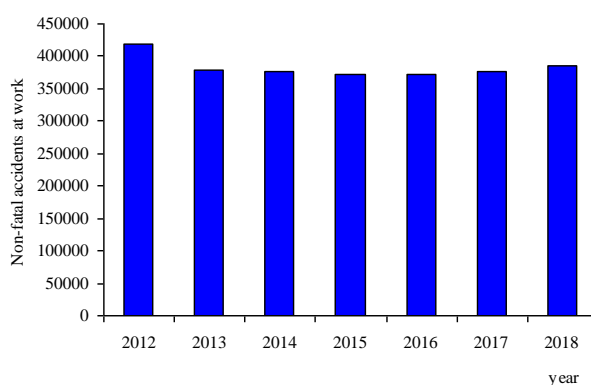
From Table 1 it is evident that the smallest number of non-fatal accidents at work in construction sector was recorded in 2016 (371737), while the smallest number fatal accidents at work were recorded in 2018 (716 persons).

**Table 1.** Total number of non-fatal and fatal accidents at work in construction sector, EU-28, 2012-2018 (persons)

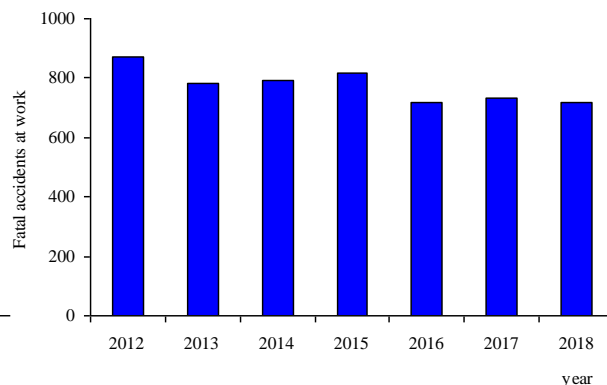
Construction (F)	2012	2013	2014	2015	2016	2017	2018
	Non-fatal accidents	418414	378018	376551	372284	371737	376008
Fatal accidents	869	784	791	815	717	733	716

Source of data: Eurostat

update: 06/08/2021



**Fig.1.** Non-fatal accidents at work, 2012-2018



**Fig.2.** Fatal accidents at work, 2012-2018

In Table 2 the number of non-fatal and fatal accidents at work in the EU-28 Member States is given. From Table 2 evident is that the highest number of non-fatal accidents at work in construction sector was recorded in Germany (118465), followed by France with (75507), and Spain with (59322). On the other hand in Latvia (188), Malta (284) and the Cyprus (308), were recorded the lowest number of non-fatal accidents at work.

In 2018, the highest number of fatal accidents at work in construction sector was recorded in Italy (123), France (101) and Germany (90). By far the lowest number of fatal accidents was reported in Cyprus (2), Denmark (3) and Estonia (3).

**Table 2.** Number of non-fatal and fatal accidents at work in construction sector, EU-28, 2018  
(persons)

	Accidents at work involving at four calendar days absence from work			Fatal accidents at work
	Total	Men	Women	Total
EU-28	385 249	376691	8515	716
Belgium	7694	7640	54	17
Bulgaria	205	199	6	21
Czech Republic	2468	2367	101	18
Denmark	7126	6832	270	3
Germany	118465	116186	2,268	90
Estonia	647	639	8	3
Ireland	2388	2241	144	5
Greece	382	373	9	8
Spain	59322	58450	872	67
France	75507	74379	1128	101
Croatia	1115	1089	25	12
Italy	28105	27637	468	123
Cyprus	308	304	4	2
Latvia	188	182	6	4
Lithuania	368	355	10	6
Luxembourg	2364	2345	19	5
Hungary	883	862	21	22
Malta	284	281	3	4
Netherlands	5768	5768	0	5
Austria	11753	11582	171	21
Poland	5047	4946	101	48
Portugal	18800	17487	1313	26
Romania	441	430	11	39
Slovenia	1464	1449	15	6
Slovakia	446	435	11	9
Finland	6681	6482	199	5
Sweden	4410	4219	190	12
United Kingdom	22619	21530	1088	34
Iceland (:)	:			
Norway	1370	1332	39	4
Switzerland	21714	21339	376	20

(:) not available

Source of data: Eurostat

update: 06/08/2021

In Table 3 the incidence rates for non-fatal and fatal accidents at work in construction sector in period from 2012 to 2018 in the EU-28 are given [3]. Across the whole of the EU-28 there were, on average, 5.90 fatal accidents per 100 000 persons employed, and on average, 2909 non-fatal accidents per 100000 persons employed in 2018.

Obviously is that in 2018 there is a decrease of incidence rates for non-fatal and fatal accidents at work in comparison with 2012. The smallest incidence rate for non-fatal accidents at work in construction sector was recorded in 2015 (2843), while for fatal accidents at work was recorded in 2018 (5.42).

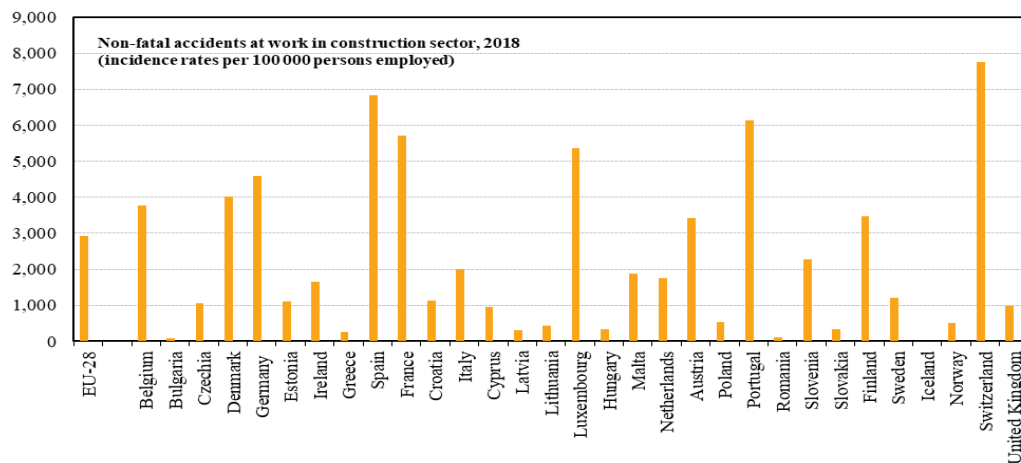
**Table 3.** Incidence rates for non-fatal and fatal accidents at work in construction sector, EU-28, 2012-2018

Construction (F)							
	2012	2013	2014	2015	2016	2017	2018
Non-fatal accidents	3067	2869	2920	2843	2879	2873	2912

Fatal accidents	6.40	5.95	6.14	6.22	5.55	5.60	5.42
-----------------	------	------	------	------	------	------	------

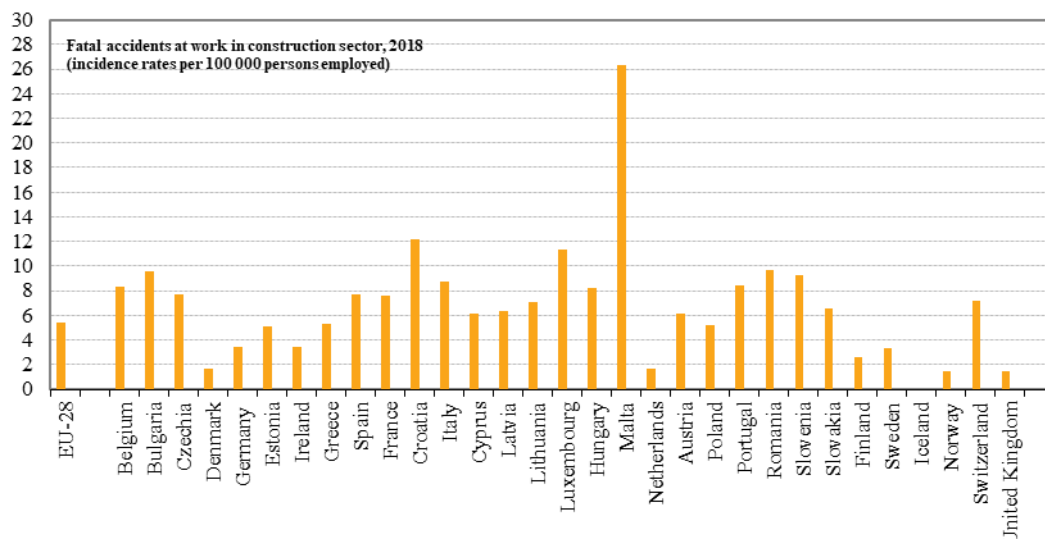
Source of data: Eurostat update: 06/08/2021

In Figures 3 and 4 the incidence rates in construction sector are shown, relating the number of accidents to the overall number of persons employed. The range for incidence rates in construction sector among the EU-28 Member States was from less than 100 accidents per 100000 persons employed in Bulgaria to more than 2750 per 100000 persons employed in Belgium, Denmark, Germany, Spain, France, Luxembourg, Portugal, Finland, and Switzerland (Fig. 3). The highest incidence rate was recorded in Spain, at 6822 non-fatal accidents per 100000 persons employed.



**Fig. 3.** Non-fatal accidents at work in construction sector, 2018 (incidence rates per 100000 persons employed)

In 2018, the number of fatal accidents in construction sector per 100000 employed persons ranged from less than 2.00 in the Netherlands, Denmark, and Norway, and to more than 8.00 fatal accidents per 100000 persons employed in Belgium, Croatia, Italy, Luxembourg, Malta, Portugal, Romania and Slovenia (Figure 4). The highest rate among the EU Member States was recorded in Malta, at 26.31 fatal accidents per 100000 persons employed.



**Fig. 4.** Fatal accidents at work in construction sector, 2018 (incidence rates per 100000 persons employed)

### Statistical indicators for non-fatal and fatal accidents at work in the Republic of North Macedonia

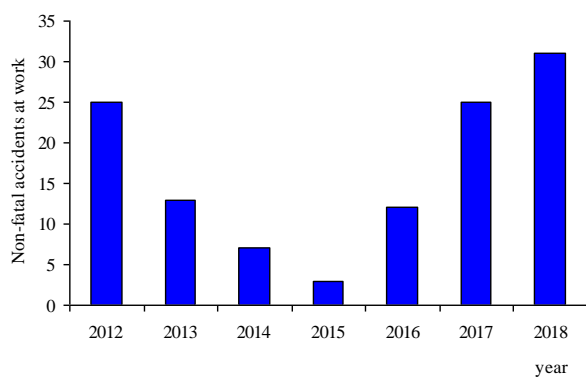
In the Republic of North Macedonia there are several organizations and institutions dealing exclusively with working conditions. These include State statistical office, the Labour inspectorate, Institute for public health, the Macedonian Occupational Safety and Health Association, Organization of the employers of Republic of Macedonia and the Trade unions. The data on the number of accidents at work in the Republic of North Macedonia is not confidential for the reason that different relevant institutions published various statistical data [4].

In this paper, the statistical indicators related to the number of non-fatal and fatal accidents at work in construction sector in the period 2012-2018 are based on the data of the Macedonian Occupational Safety and Health Association [5-11]. The reason for that is what in the statistical reports of the other relevant institutions that register accidents at work no distinction is made between the number of non-fatal and fatal accidents at the workplace. In construction sector in 2018 there were 31 non-fatal accidents that resulted in at least four calendar days of absence from work and 8 fatal accidents (Table 4). In the total number of non-fatal accidents at work in the Republic of North Macedonia between 2012 and 2018, there was increase for 6 accidents i.e. equivalent to enlargement of 19.35 % (Fig. 5). During on 2018, there were 5 fatal accidents at work fewer when compared with 2012 i.e. equivalent to increase of 62.5% (Fig. 6). From Table 4 it is evident that the smallest number of non-fatal in 2013, while the smallest number of fatal accidents at work was recorded in 2012.

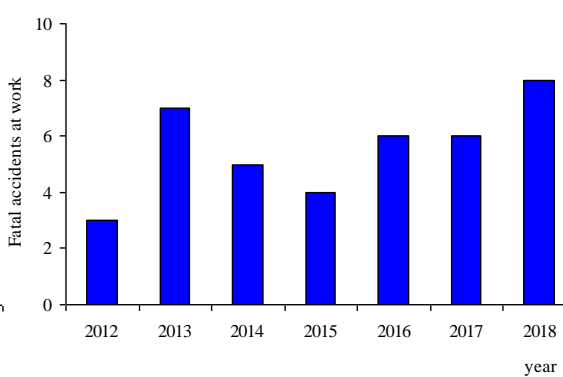
**Table 4.** Total number of non-fatal and fatal accidents at work in construction sector, Republic North Macedonia, 2012-2018 (persons)

Construction (F)	2012	2013	2014	2015	2016	2017	2018
	Non-fatal accidents	25	13	7	3	12	25
Fatal accidents	3	7	5	4	6	6	8

Source: Macedonian Occupational Safety and Health Association



**Fig.5.** Non-fatal accidents at work, 2012-2018



**Fig.6.** Fatal accidents at work, 2012-2018

In Table 5 the incidence rates for non-fatal and fatal accidents at work in period from 2012 to 2018 in construction sector are given [5-11]. In the period between 2012 and 2018, there is decrease in the incidence rate for non-fatal accidents at work. In comparison with the values of incidence rates of EU-28 Member States, the Republic of North Macedonia can be classified in the country with incidence rates less than 100. From Table 5 evident is that the smallest incidence rate for non-fatal accidents at work in construction sector was recorded in 2015 (0.45).

**Table 5.** Incidence rates for non-fatal and fatal accidents at work in construction sector, Republic of North Macedonia, 2012-2018

Construction sector	Incidence rates (per 100,000 persons employed)						
	2012	2013	2014	2015	2016	2017	2018
Non-fatal accidents	5.31	1.97	1.06	0.45	1.82	3.35	4.08
Fatal accidents	1.36	1.06	0.76	0.61	0.91	0.81	1.05

There is an equivalent decrease in the incidence rate for fatal accidents at work for 29.5% in the period between 2012 and 2018. The smallest incidence rate for fatal accidents at work was recorded in 2015 (0.61). The incidence rate of fatal accidents at work in 2018 in the Republic of North Macedonia was 1.05 deaths cases from accidents at work per 100000 persons employed. In comparison with the mean value of the incidence rates in EU-28 (5.42), the incidence rate in the Republic of North Macedonia is much lower.

## CONCLUSION

In this paper the statistical indicators for non-fatal and fatal accidents at work in EU-28 Member States and in the Republic of North Macedonia from 2012 to 2018 in construction sector were presented. From the statistical indicators for the number of non-fatal and fatal accidents at work in the EU-28 Member States, may be concluded that there is considerable reduction of number of accidents at work in construction sector in relation to 2012. The situation with the accidents at work (non-fatal and fatal accidents at work) in construction sector in Republic North Macedonia in 2018 is opposite than the EU-28 Member State. Therefore, it is necessary to build and maintain a national preventive culture and introduce a systemic approach to managing occupational safety and health at work, as an important prerequisite for reducing the number of accidents at work in the construction sector.

## REFERENCES

- [1] European Statistics on Accidents at Work (ESAW), Summary methodology, 2013.
- [2] Eurostat, Accidents at work statistics, Published on [https://ec.europa.eu/eurostat/statistics-explained/index.php?title=Accidents\\_at\\_work\\_statistics#Number\\_of\\_accidents](https://ec.europa.eu/eurostat/statistics-explained/index.php?title=Accidents_at_work_statistics#Number_of_accidents), 2018 Last update of: 06.08.2021.
- [3] Ferrett, H. E.: Introduction to Health and Safety in Construction, 2007.
- [4] Mitrevska, C., Mitrevska, E., Mitrevski, B., Geramitcioski, T., Mijakovski, V., Mitrevski, V.: Analysis of non-fatal and fatal accidents at work by economic activities in European Union and the Republic North Macedonia, IX International Conference Industrial Engineering and Environmental Protection 2019 (IIZS 2019), pp. 244-252, Zrenjanin, Serbia, October 3-4, 2019.
- [5] Annual Report for fatalities, injuries and accidents at work 2012, Macedonian Occupational Safety and Health Association, 2012.
- [6] Annual Report for fatalities, injuries and accidents at work 2013, Macedonian Occupational Safety and Health Association, 2013.
- [7] Annual Report for fatalities, injuries and accidents at work 2014, Macedonian Occupational Safety and Health Association, 2014.
- [8] Annual Report for fatalities, injuries and accidents at work 2015, Macedonian Occupational Safety and Health Association, 2015.
- [9] Annual Report for fatalities, injuries and accidents at work 2016, Macedonian Occupational Safety and Health Association, 2016.
- [10] Annual Report for fatalities, injuries and accidents at work 2017, Macedonian Occupational Safety and Health Association, 2017.
- [11] Annual Report for fatalities, injuries and accidents at work 2018, Macedonian Occupational Safety and Health Association, 2018.

## IMPROVING WORKPLACE SAFETY USING ADVANCED INDUSTRY 4.0 TECHNOLOGIES

Marija Savković<sup>1</sup>, Marica Dašić<sup>2</sup>, Marko Đapan<sup>1</sup>, Arso Vukićević<sup>1</sup>, Ivan Mačužić<sup>1</sup>,  
Miladin Stefanović<sup>1</sup>

<sup>1</sup> University of Kragujevac, Faculty of Engineering, Sestre Janjić 6, Kragujevac, Serbia,  
e-mail: [marija.savkovic@kg.ac.rs](mailto:marija.savkovic@kg.ac.rs)

<sup>2</sup> AMM Manufacturing d.o.o., Aleja Milanović bb, 34325 Kragujevac

**Abstract:** Taking into account the fact that safety and health at work is one of the main components of financial success in all contemporary industrial systems that operate on lean principles, special attention is paid to the continuous improvement of safety and health of workers. A comprehensive transformation of industrial production and complete automation and digitalization of production processes is supported by Industry 4.0. Industry 4.0 is characterized by intelligent networking of physical objects over the Internet, interactions, communications and data exchange between all physical entities and the application of modern advanced technologies (collaborative robots, artificial intelligence, nanotechnology, virtual reality, augmented reality, Internet of Things, big data, cloud computing, 3D printers, drones and autonomous vehicles). It creates significant changes in production, work organization, and the way how workers perform their activities. Moreover, Industry 4.0 has a significant impact on workplace safety.

The paper presents the connection between workplace safety and Industry 4.0 through the analysis of the most important research papers in this field. Also, the paper presents the most significant modern advanced digital technologies of Industry 4.0 that have applications in the field of safety and health of workers (sensors and wearable technologies, exoskeletons etc.). Special attention in the paper is paid to emphasizing the positive effects and benefits of the application of these modern advanced technologies. The main goal of the application of these modern innovative technologies is to improve workplace safety through the prevention of injuries at work, occupational diseases and deaths and to improve the general health and well-being of workers. The paper is a part of research activities in the field of research of possibilities for improving the effectiveness of production processes by applying modern advanced technologies of Industry 4.0.

**Keywords:** *Advanced technologies, Collaborative robots, Exoskeleton, Industry 4.0, Workplace safety, Safety 4.0*

### INTRODUCTION

Taking into account the fact that improving safety and health at work is one of the main indicators of an organization's financial success, contemporary industrial systems operating on lean principles strive to achieve the highest level of occupational safety and health at work (OSH). Minimizing injuries at work and achieve such work conditions in which workers would have a sense of satisfaction directly contribute to increasing productivity, reducing costs and increasing product quality. Injuries at work and occupational diseases lead to a reduction or in certain situations loss of working ability and reduction of life activities and often cause absence from work, which further causes downtime in production, increased costs and expenses.

Industry 4.0 represents a new production paradigm that causes changes in production, work organization, the way on work activities are performed, and this is increasingly reflected in the safety and health of workers. Real-time networking and information exchange, big data, collaborative cooperation of operators and robots, remote detection, real-time process monitoring and control, autonomous digital technologies are becoming the basic characteristics of modern industrial systems.

The research paper points out the connection between workplace safety and Industry 4.0 entitle as Safety 4.0. The main purpose of scientific research is to through critical analysis and synthesis of conclusions from scientific research papers in the OSH field and Industry 4.0 answer questions about how Industry 4.0 affects the safety and health of workers and how the application of innovative technologies Industry 4.0 can lead to improved safety and health of workers.

Automated systems, collaborative robots, exoskeletons and smart machines, smart personal protective equipment, autonomous vehicles have a positive impact on occupational safety and health. It improves general health and welfare of workers since these entities replace workers in performing daily complex and precise monotonous activities and enable workers to perform these tasks in a more efficient,



productive, flexible and safer way and enable monitoring of parameters in the work environment that affect the process, [1], [2], [3], [4].

Industrialization has undergone great transformations since its beginnings in the 18th century, and all these changes have affected the safety and health of workers. During the first industrial revolution, child labor was a common occurrence and the work environment was extremely dangerous. Also, in this period, the application of OSH laws was very limited, [5]. The increase in the number of workers during the second revolution led to small investments in companies in programs for improve safety and health at work. OSH laws have begun to be applied in a many countries. A turning point in the adoption and implementation of laws in the field of safety and health at work was the Act passed in Great Britain in 1974, which required employers to take certain measures to increase the safety and health of workers, [5], [6]. During the third industrial revolution, a new occupational safety and health strategy called the OSH 3.0 strategy was created. The novelties in this strategy are related to the implementation of risk assessment in the workplace and the introduction of preventive measures to protect workers, reduce injuries at work and occupational diseases, improve workplace conditions and promote "total" health [5], [6]. Special emphasis in this period was placed on increasing the safety of machines. The new occupational safety and health strategy related to the fourth industrial revolution aims to promote, improve and enhance OSH in line with the specifics of Industry 4.0. This includes the use of new technologies (mobile devices, wearable technologies and sensors) and the application of new tools to predict the occurrence of OSH risks. The paper is structured as follows: After the introductory part and defining the concept of Industry 4.0, the paper presents the most significant modern advanced digital technologies of Industry 4.0 that have applications in the field of occupational safety and health (collaborative robots, sensors and wearable technologies, exoskeletons, augmented reality) and this paper points out the positive effects and benefits of applying these modern advanced technologies. Concluding remarks are made in the conclusion.

## **MATERIAL AND METHODS**

Industry 4.0 is a very important area that is attracting increasing attention from researchers and experts in many fields. This can be concluded on the basis of a large number of scientific research papers written in this field. A detailed review of the literature concludes that a small number of scientific research papers have been written that indicate the link between Industry 4.0 and occupational safety and health.

McKinsey defines Industry 4.0 as the next phase in the digitalization of the manufacturing sector, characterized by a sharp increase in data and an increasing role for analytics and business reporting, comprehensive networking of facilities, and a collaborative form of cooperation between workers and collaborative robots. Industry 4.0 is based on connecting the real and virtual world, connecting modern innovative technologies and traditional production processes. Everything within the smart company (products, semi-finished products, machines, equipment, tools, workers and collaborative robots, etc.) and around the company (suppliers, distributors, customers, etc.) is digitally networked. All entities communicate with each other and exchange data in real time. Connecting entities via the Internet to the network enables the exchange of data and facilitates their control and monitoring. All objects within the cyber physical system have the ability to make decentralized decisions, take the initiative and independently control.

Industry 4.0 implies full automation and digitalization of production through the application of modern digital technologies, and transformation of production in such a way that isolated production cells are interconnected and integrated into a smart system, [7], [6], [8]. It changes traditional relationships externally between suppliers, manufacturers and customers and internally between workers and collaborative robots, machines and components, [9]. Highly automated smart companies are characterized by virtualization, interoperability, modularity, production process optimization, decentralized decision making, service orientation through creating new value and providing innovative customer service and independent process management. The key features of Industry 4.0 are horizontal integration, vertical integration and system-wide integration, and digitization of information during the product life cycle (end-to-end engineering). Of particular importance in smart enterprises are artificial intelligence, nanotechnology, biotechnology, the Internet of Things, big data,

cloud computing, 3D printers, collaborative robots and autonomous vehicles, [10]. The primary goal of applying these technologies is to improve operational performance, efficiency and productivity.

### **Industry 4.0 technologies that have an impact on workplace safety**

Collaborative robots are a special type of robot that cooperates collaboratively with workers in a shared workspace and assists them in performing daily activities to perform activities more efficiently, flexibly, and safely. Increased interaction and collaborative cooperation between workers and robots is the foundation of Industry 4.0, [11]. Collaborative robots are embedded with sensors that allow them to perceive the environment, react to dynamic conditions, and recognize objects in their vicinity, [11], [3]. These autonomous robots are very intelligent, perform activities faster and more accurately than robots, and take up less space, [12].

Exoskeletons are mechanical devices that workers carry and that have the role of supporting workers in performing difficult, manual and physically demanding work tasks that cannot be automated (such as lifting loads and handling loads).

Knowledge-based smart machines equipped with sensors and cameras have the ability to self-monitor and self-control and independently predict errors and dysfunctions that could occur during their operation, [13]. Rapid advances in robotics, artificial intelligence, computer vision, and edge computing capabilities are resulting in smart machines that can potentially think, see and move more deftly than workers. These autonomous machines are self-maintained by sending information to diagnostic centers to determine whether additional interventions related to the maintenance of these machines are necessary, [6], [14]. In this way, it is possible to determine in real time on which machine the failure occurred and to redirect the products to another machine.

Mobile smart wearable digital technologies (eg smart bracelets, smart glasses) and mobile miniature devices built into smart personal protective equipment (helmets, hats, protective suit or hand straps) enable continuous monitoring of workers' activities and health parameters and working environment conditions in real time [15].

Augmented reality is a combination of the physical and digital worlds, in which digital elements (image, text, animation or sound) complement the physical world. Augmented reality allows real-world information to be accompanied by computer-generated data (images, text) that are combined into one unit displayed on computer screens or mobile phones, or computer-generated images are projected onto real objects in real time.

The Internet of Things (IoT) is a network of physical objects, with built-in sensors and actuators, that are connected via the Internet. IoT technologies allow plant facilities to exchange data with each other. These technologies enable the collection of data on the plant and the processes, and based on the processing of this data in the cloud and the processing results, production management can be corrected.

Another characteristic of smart companies is the rapid growth of the amount and variety of unstructured data that come from different sources (smartphones, tablets, sensors built into various devices, machines, tools, plants) and must be collected, processed and analyzed in real time. Big data represents data whose size exceeds the capabilities of traditional databases and software to collect, process, analyze, and store data.

The continuous need to process, analyze and store large amounts of data has led to the increasing use of cloud computing. Cloud computing is the outsourcing of IT infrastructure (hardware and software) using the Internet and its use as needed. Cloud computing enables the use of various IT services on physically remote servers with the help of network infrastructure and appropriate Internet protocols. Every machine, device and component in a smart enterprise generates data stored in the cloud, then this large data collected within the enterprise and value chain is processed so that real-time performance can be monitored and analyzed, compared with historical data and institutions problems that may arise, [16].

Virtual reality represents the use of information technology for the exact and realistic representation of environment scenarios such as work situations and their properties. Virtual reality embeds the workers in the virtual world and permits interaction with this environment in real time.

Artificial intelligence is the branch of computer science which deals with the study and design of intelligent agents that perceives environment, speech recognize, learn, plan and problem solve.

Artificial intelligence represents the simulation of human intelligence processes by machines, especially computer systems.

Autonomous vehicles represent a new form of self-driving vehicles that can move independently and can operate independently with video camera, radar sensors and laser rangefinders on the basis of which he can "see" others objects in plant. Autonomous vehicles possess the capabilities to recognize and maneuver around obstacles. These smart cars perceive environment using technologies such as radar, GPS, artificial intelligence and machine vision. Advanced control systems interpret the collected sensors information to identify appropriate navigation paths, as well as obstacles and relevant signaling.

## **RESULTS AND DISCUSSION**

### **Positive effect of advanced industry 4.0 technologies application on occupational health and safety**

Collaborative robots, exoskeletons, artificial intelligence, virtual reality, augmented reality, the Internet of Things, big data, cloud computing and autonomous vehicles contribute to improving the safety and health of workers.

Collaborative robots contribute to the improvement of the health of workers by replacing workers in complex, dangerous and physically demanding activities and facilitate the performance of precise, monotonous, repetitive activities (such as assembly work). These modern autonomous robots are characterized by less complexity and easy control. Unlike conventional robots that operate on the principle of pre-programmed commands, collaborative robots have built-in sensors that allow them to recognize and analyze workers' intentions and adapt their activities to workers' abilities. In this way, stress, burnout and annexation in workers are reduced and their health condition is improved. Also, collaborative robots have the ability to self-control by reducing or increasing speed depending on the proximity of the worker. Collaborative robots are safe to work with workers and do not have to be fenced like classic robots. They are programmed to stop work when the worker enters in the shared workspace and continue to work when the workspace is vacated, [17]. Also, if a person enters in the zone of action of collaborative robots, it can change activities, reduce the speed of work and thus not endanger the occupational safety of workers.

Exoskeletons have the role of enhancing the physical abilities of workers (eg strength and endurance), reducing the compression of force on the lower back, shoulders, elbows and joints and thus protecting workers from injuries that may occur on these parts of the body. The use of exoskeletons reduces fatigue and physical exertion and improves the general health of workers. They provide support to the body of the worker during positioning or use of tools, handling of objects etc. Active exoskeletons use actuators to support the movement and activities of workers who perform fatigue activities (pushing, lifting, pulling, etc.) for an extended period of time in an incorrect position, giving them extra strength and increasing their performance, [18]. The active exoskeleton for the upper body in Fiat in Italy was used to provide support to the hands of the workers so that the workers could lift the load without any difficulties. In this way, the load on the joints and muscles is reduced and the health condition of the workers is improved. The passive exoskeleton for the lower part of the body has the role of being set as a "chair" and is applied when workers often change positions or stand for a long period of time. The application of this exoskeleton reduces the load on the legs and facilitates the adoption of correct positions on the one hand, while maintaining flexibility and mobility on the other hand, [17].

Smart exoskeletons are a special type of exoskeleton that incorporates sensors that have the role of monitoring the health parameters of workers in real time and indicate non-ergonomic movements and body positions and in that way improve the health of workers. The benefits of the application are reflected in the reduction of muscle fatigue, avoidance of tension, stretching and bending, and reduction of injuries to the operator.

In October 2018, Hyundai Motor Group at the North American plant Hyundai-KIA began testing the Hyundai Vest Exoskeleton (H-VEX), (which aimed to reduce pressure on workers' necks and backs) and the Hyundai Chairless Exoskeleton (H-CEX) which is set up as a "chair" and is used by workers who have to stand for a longer period of time during the performance of activities. After the

application of these exoskeletons, injuries at work and occupational diseases were reduced and the efficiency and productivity of workers was increased.

The use of exoskeletons also contributes to improving the health of workers and reducing injuries of workers who perform repetitive activities up to 8 hours a day continuously in an incorrect position (eg with arms raised above the head) and reduce pain in the neck, shoulders, back (most common in these workers).

Smart machines have the ability to perform advanced analysis and prediction of potential hazards that may occur and the ability to manage unexpected situations that may occur during operations, thus preventing accidents and injuries to workers, [16], [6]. Some smart machines can accurately interpret the emotions and intentions of workers and in this way increase the safety and health of workers.

Mobile smart wearable digital technologies identifies and monitors hazardous situations that can cause accidents [19]. In this way, the safety and health of workers is ensured and improved. The benefits of applying these new technologies are reflected in real-time risk assessment and decision-making on the preventive and corrective measures (taking into account his health condition) to eliminate accidents and reduce injuries at work, [20].

The sensors monitor the movement of the worker, the location of the worker, the number of steps the worker has taken, the activities he performs, the position he occupies etc. Monitoring the basic health parameters of workers (heart rate, pulse, temperature, stress level, fatigue, concentration) can indicate the physical and cognitive load of the operator, anti-ergonomic movements and body positions, reduces worker stress, reduces cognitive and physical load and avoids work injuries.

Palazon et al. suggest that innovative technologies play a significant role in improving working environment conditions, [4]. These innovative digital devices enable workers to remain safe in environments such as with high temperatures, toxic gases, harmful chemicals and high noise levels by indicating abnormalities that can adversely affect on OSH, [21].

By applying innovative technologies, it is possible to determine whether OSH procedures and rules are followed, to identify which workers are particularly at risk, which workers should attend additional training in the field of safety and health at work in order to perform activities in a safer way. Moreover, training instructors in this way can adapt the training in the OSH field to each worker individually in accordance with his situation.

By connecting sensors to smart technologies (accelometer sensor, gyroscope sensor, magnetometer, dust sensor, smoke sensor, gas sensor etc.), workers receive warnings about potential exposure to hazards and harms, and allow the injured worker to seek help if needed, [22], [2], [23].

Augmented reality finds great application during employee training by increasing operator flexibility, shortening the time required to learn a new task and reducing the number of mistakes made by the worker, which further improves worker safety and health, [5].

Virtual reality finds application in risk assessment of workplaces and work equipment. Also, virtual reality enables more efficient implementation of employee training. The dangers and risky situations that may arise can be practically presented by applying virtual reality. Martinetti et al. tested the application of virtual reality for the training of vehicle maintenance technicians and pointed out the benefits of applying this technology in the field of OSH, [24].

According to Heinrich's safety pyramid every accident and serious accident is preceded by a large number of omissions, uncertain actions and other events. Therefore, the most effective way to prevent accidents and incidents is to collect data. Mattsson et al. believe that the collection, integration, and analysis of big data from workplaces in intelligent work environments has a positive impact on worker safety and health through improved performance, stress reduction, and accident prevention, [2]. The collected data indicate the possibility of accidents and harmfulness in the workplace. In this way, it is possible to eliminate and control hazards before an accident happens. Combining data collected from sensors in the previous period with real-time data facilitates decision-making and it has a positive impact on worker safety.

Artificial intelligence plays an important role in improving OSH and wellbeing of workers. Artificial intelligence-based digital technologies enable workers to be tracked and directed based on the collection of large amounts of data in real time via mobile devices, control devices worn on clothing, or embedded in personal protective equipment, or the workers body. The application of artificial intelligence methods enables timely decision-making and risks and dangers are recognized and prevented, [25].

Autonomous vehicles replace workers in performing activities. In this way, OSH is improved. Cameras monitor the movements and activities of workers and detect any irregularities that may occur in real time.

The fourth industrial revolution led to the appearance of significant changes in production, work organization, and the way workers perform their activities as well as on safety and health of workers. All these innovative technologies of Industry 4.0 contribute to workplaces in contemporary industrial systems be safer, more ergonomic and more comfortable, and this will further increase the economic effects - productivity and efficiency of workers (Table 1.).

The benefits of applying the innovative technologies of Industry 4.0 are reflected in the overall improvement of the health and safety of workers. Continuous monitoring and supervision of parameters from the work environment and monitoring the health of workers in real time in combination with analytics achieves safer working conditions, eliminates accidents and deaths, reduces injuries at work and occupational diseases and creates a basis for the application of personalized preventive measures.

**Table 1.** Advantages of applying the basic components of Industry 4.0, [25]

<b>Component</b>	<b>Application benefits</b>
Big data	unlimited data collection reducing uncertainty improving capacity for vital parameter analysis and error prevention
Internet of things	improving machine/equipment interactions and detecting anomalies and dysfunctions that may occur
Cyber-physical systems	improving process monitoring and control remote monitoring and control
Collaborative robots	improves human-robot interaction improves safety and health of workers
Artificial intelligence	learning and quickly recognizing dangers real-time decision making
Simulation	improving assessment prevention at source

## CONCLUSION

The application of innovative Industry 4.0 technologies improves OSH by enabling the detection and elimination or reduction of hazards that may endanger the life and health of workers. By improving working conditions, reducing occupational injuries, occupational and work-related illnesses, preconditions are created for the physical, mental and social well-being of employees and the improvement of economic indicators - efficiency and productivity.

The application of innovative Industry 4.0 technologies allows workers to perform activities in a safer and more flexible way. The application of these technologies contributes to reducing the occurrence of occupational diseases and injuries at work and improving the health of workers by reducing repetitive/monotonous work activities, reducing stress and creating a better work-private life balance, reducing the risk of occupational diseases by monitoring basic health parameters of workers (monitoring muscle and brain activity using EMG and EEG sensors placed in personal protective equipment) in real time and showing warnings to workers about the occurrence of danger or harm, facilitating the implementation of preventive measures and improving working conditions through continuous monitoring of parameters in the work environment in real time (humidity, noise, lighting, etc.) and reducing or eliminating their negative impact.

In intelligent work environments, workers are given the opportunity to qualitatively enrich their work activities and reduce the performance of heavy physical work and monotonous repetitive precision work activities, since these activities are mostly performed by collaborative robots. Workers are

involved in performing activities that add value - creative activities that require reasoning, decision-making and solving problem situations in case of unforeseen events. Workers in smart companies monitor automated machinery and equipment, make decisions independently and take the initiative, manage and solve problems if unforeseen situations arise that could endanger their health or life and thus improve OSH. Workers are less exposed to stress because they can organize their activities independently, and achieve a greater degree of autonomy and self-development. Flexible working conditions in intelligent work environments enable workers to achieve a better balance between work and private life and between personal and professional development, which further leads to increased worker satisfaction and motivation to work, and reduced physical and cognitive load.

Worker-machine integration has a positive effect on OSH through the reduction of accidents and injuries at work, improving worker safety and improving ergonomic aspects in the workplace. The combination of digital wearable technologies, smart personal protective equipment, cameras, artificial intelligence can predict the potential dangers that may occur in the workplace, and this further enables the prevention of accidents and injuries to workers.

## REFERENCES

- [1] Podgórski, D., Majchrzycka, K., Dąbrowska, A., Gralewicz, G., Okrasa, M., Towards a conceptual framework of OSH risk management in smart working environments based on smart PPE, ambient intelligence and the Internet of Things technologies, *Int. J. Occup. Safe. Ergon*, 23 (1), pp.1-20, 2017
- [2] Mattsson, S., Partini, J., Fast-Berglund, Å., Evaluating four devices that present operator emotions in real-time, *Procedia CIRP* 50, pp. 524–528, 2016
- [3] Beetz, M., Bartels, G., Albu Schaffer, A., Balint Benczedi, F., Belder, R., Bebler, D., Haddadin, S., Maldonado, A., Mansfeld, N., Wiedemeyer, T., Weitschat, R., Worch, J. H., Robotic agents capable of natural and safe physical interaction with human co-workers, *IEEE International Conference on Intelligent Robots and Systems*, art. no. 7354310. pp. 6528-35, 2015
- [4] Palazon, J. A., Gozalvez, J., Maestre, J. L., Gisbert, J. R., Wireless solutions for improving health and safety working conditions in industrial environments, u: *IEEE 15 th International Conference on eHealth Networking, Applications and Services, Healthcom*, pp. 544- 548, 2013
- [5] Chia, G., Lim, S. M., Sng, G. K. J., Hwang, Y. J., Chia K. S., Need for a new workplace safety and health (WSH) strategy for the fourth Industrial Revolution, *Am J Ind Med*.62 (4), pp. 275-281, 2019
- [6] Polak- Sopinska, A., Wisniewski, Z., Walaszczyk, A., Maczewska, A., Sopinski, P., Impact of Industry 4.0 on Occupational Health and Safety, *International Conference on Applied Human Factors and Ergonomics*, pp. 66-76, 2019
- [7] Kagermann, H., Helbig, J., Hellinger, A., Wahlster, W., Recommendations for implementing the strategic initiative INDUSTRIE 4.0: securing the future of German manufacturing industry, final report of the Industrie 4.0 Working Group, *Forschungsunion*, 2013
- [8] Mareseova, P., Soukal, I., Svobodova, L., Hedvicakova, M. Javanmardi, E. Selamat, A. Krejcar, O., Consequences of Industry 4.0 in Business and Economics, *ECONOMIES*, 6 (3), 46, 2018
- [9] Rüßmann, M., Lorenz, M., Gerbert, P., Waldner, M., Justus, J., Engel, P., Harnisch, M., Industry 4.0: The Future of Productivity and Growth in Manufacturing Industries, *Boston Consulting Group*, 2015, available at <https://www.zvw.de/media>
- [10] Bahrin, Brettel, M., Klein, M., Friederichsen, N., The relevance of manufacturing flexibility in the context of Industrie 4.0, *48 th CIRP Conference on Manufacturing Systems, Procedia CIRP* 41., pp. 105–110, 2016
- [11] Bonini, M., Prenesti, D., Urru, A., Echelmeyer, W., Towards the full automation of distribution centers, *4th IEEE International Conference on Advanced Logistics and Transport, IEEE ICALT* 7136589, pp. 47–52, 2015

- [12] Görür, O., Rosman, B., Sivrikaya, F., Albayrak, S., Social Cobots: Anticipatory Decision Making for Collaborative Robots Incorporating Unexpected Human Behaviors, *ACM/IEEE Int'l, Conference on Human-Robot Interaction*, 2018
- [13] Lasi, H., Fettke, P., Feld, T., *Industry 4.0*, *Bus Inform Syst Eng*, 6, pp. 239-242, 2014
- [14] Roblek, V., Meško, M., Krapež, A., *A Complex View of Industry 4.0*, *SAGE Open* 2016, pp. 1-11, 2016
- [15] Barata, J., Cunha, P. R., *Safety is the New Black: the increasing Role of Wearables in Occupational Health and Safety in Construction*, Chapter, Published in: *Business Information Systems book*, Springer International Publishing, 2019
- [16] Lee, J., Kao, H. A., Yang, S., *Product Services Systems and Value Creation*, *Proceedings of the 6th CIRP Conference on Industrial Product-Service Systems, Service innovation and smart analytics for Industry 4.0 and big data environment*, *Procedia CIRP* 2014: 16, pp. 3-8, 2014
- [17] Bragança, S., Costa, E., Castellucci, I., Arezes, P., *A Brief Overview of the Use of Collaborative Robots in Industry 4.0: Human Role and Safety Wandel Durch Partizipation*, pp. 641-650, 2019
- [18] Kong, X., Luo, H., Huang, G., Yang, X., *Industrial wearable system: the human-centric empowering technology in Industry 4.0*, *Journal of Intelligent Manufacturing*, pp. 1-17, 2018
- [19] Lees F., *Lees' Loss Prevention in the Process Industries: Hazard Identification, Assessment and Control*, BUTTERWORTH-HEINEMANN (fourth ed.), 2012
- [20] Gorli, R., *Smart Jacket for Industrial Employee Health and Safety*, *International Journal of Scientific Research in Computer Science, Engineering and Information Technology*, Volume 2, Issue 3, pp. 2456-3307, 2017
- [21] Lymberis, A., *Smart wearables for remote health monitoring, from prevention to rehabilitation: current R&D, future challenges*, In *Information Technology Applications in Biomedicine*, 4th International IEEE EMBS Special Topic Conference, pp. 272-275, 2003
- [22] Ledda, A., Palomba, R., *Innovative Wearable Systems for Improving Workers' Safety* Springer Nature Switzerland AG 2020T, Ahram et al. (Eds.): *IHIET 2019*, AISC 1018, pp. 332-337, 2020
- [23] Orji, R., Moffatt, K., *Persuasive technology for health and wellness: State-of-the-art and emerging trends*, *Health Informatics J.* 24, pp. 66-91, 2018
- [24] Martinetti, A., 't Hart, K., Damgrave, R., van Dongen, L. A. M., Turkenburg, R., Nouwens, A., *There is no spoon: applying virtual reality for maintenance training of rolling stock technicians*, *International Journal of System of Systems Engineering, SI: Critical Success Factors for Public Transportation*, 2018b
- [25] Badri, A., Boudreau-Trudel, B., Souissi, A. S., *Occupational health and safety in the industry 4.0 era: a cause for major concern?*, *Safety Science*, 109, pp.403-411, 2018
- [26] Chiabert, P., D'Antonio, G., Maida, L., *Industry 4.0: technologies and OS&H implications*, *Geingegneria Ambientale e Mineraria*, issue 154 (2), pp. 21-26, 2018
- [27] Leso, V., Fontana, L., Lavicoli, I., *The occupational health and safety dimension of Industry 4.0*, *Med. Lav.* 110 (5), pp. 327-338, 2018

## DEVELOPMENT OF RISK MANAGEMENT PROCESS IN INDUSTRY

Milica Josimovic<sup>1</sup>, Milos Josimovic<sup>1</sup>, Slavica Prvulovic<sup>1</sup>

<sup>1</sup>University of Novi Sad, Technical Faculty "Mihajlo Pupin", Zrenjanin, Serbia

E - mail: [milicajosimovic0103@gmail.com](mailto:milicajosimovic0103@gmail.com)

**Abstract:** The paper examines the process of risk management in industry with reference to possible hazards that may occur in the production process, such as fire risk, working environment risk, risk of breakage of machinery and equipment, risks of liability from the industry, risks of liability for product defects, the risk of interruption due to the realization of some basic risk.

It has been established that through the risk management process, the organization protects its interests as well as the interests of its business environment, the environment and the community in which it operates.

**Key words:** risk, industry, insurance, development.

### INTRODUCTION

Risk has always attracted the attention of a large number of researchers and scientists, but mostly from different aspects, so that even today there is no single definition of risk. The notion of risk is very relative, but all risks have in common that there must be future and uncertain events. In the most general case, the occurrence of an economically harmful event is considered at risk. Due to its properties, risk is a thought term whose intuitive meaning can be connected with the lack of knowledge about the future and the possibilities of unfavorable outcomes [1, 2].

All definitions suggest that the notion of risk is a kind of phenomenon and even an important philosophical question. Therefore, it is best to explain the risk, as a complex quantity that includes the probability of occurrence of a harmful event and the expected consequence of that event, through these two quantities, ie through the probability of damage and the intensity, extent or magnitude of damage, which is usually expressed through monetary amount, whereby the given system of damage events must be rounded and be within a certain time interval [2].

Risk management includes a set of management methods and techniques used to reduce the possibility of achieving adverse events and consequences and thus increase the possibility of achieving the planned results [3, 4].

Risks multiply and become more complicated with the development of technology and the rise of the general social standard. This means living with risk, and that is why individuals and society are finding ways to manage it.

### MATERIAL AND METHODS

#### Risk management process

The risk management process itself is basically a multidisciplinary process in which different: knowledge, disciplines and methods are used together in order to solve problems related to risk. Namely, it is a systematic process for: identifying, examining and assessing the possibility of damage faced by an organization or individual, as well as a systematic process for selecting the best way to handle all possible risks that is in line with the goals of a particular organization or individual [2, 3].

The basic concept of the risk management process tends to translate risk from the framework of uncertainty and unknown into the framework of cognition and certainty. Contributes to this: the collection, processing and storage of information needed to understand the possible positive and negative aspects of all factors that may affect the realization of an event. Such a process increases the probability of success and reduces both the probability of failure and the uncertainty about achieving the overall goals of the organization.

Before starting the risk management process itself, it is necessary to determine the goals of the risk management program, ie to decide precisely what a company expects from its risk management program [2,3].



Risk analysis is a procedure aimed at identifying system vulnerabilities, identifying potential hazards (risks) and appropriately quantifying the possible consequences in order to select the most effective method of protection, ie to assess the justification of introducing additional countermeasures. The risk analysis must determine the following facts: critical resources and their value (relative or monetary), an overview of possible hazards and the probability of their occurrence, potential losses caused by the realization of the hazard, recommended countermeasures (supervision) and protection.

In the field of engineering where the risk of technical systems (machines and plants) is considered, risk management has roots in industries with complex, highly developed technology and safety requirements, such as power plants, chemical industry, aeronautics and electronics industry [5, 6].

A complete description of the risk is an iterative process, which usually begins with the application of qualitative methods which, if necessary, are converted into quantitative ones. If a quantitative risk analysis is performed, a system model must be established. Once the model and data have been determined, a budget can be started to assess the risk and identify critical components and events. The presented definition of risk management process is used in the field of safety of technical systems, but in this form, with minor adaptations, it is applicable in the chemical, nuclear, as well as in the construction industry. The analysis of the causal chain of risk events indicates that the state of failure is preceded by the state of system risk. Therefore, the study of risk status is extremely important for the maintenance of technical systems [4, 5].

Risk ranking allows managers to prioritize prevention activities and resources for a risk scenario. Risk analysis can be divided into different levels of detail, such as. in the nuclear industry, where risk analysis is performed at three levels: level 1- system analysis, analysis of the probability of occurrence of critical conditions; level 2- system analysis and analysis of the consequences of the occurrence of various critical states with appropriate probabilities; or level 3 - further analysis for possible (negative) effects on humans, including assessment of danger to human life, and cases where this may occur.

The final product of the risk analysis then depends on the levels of detail used, and should be determined when defining the subject of the analysis, ie before performing the analysis.

## **RESULTS AND DISCUSSION**

### **Risk in industry**

The system is built of parts, components and subsystems and it is very important to carefully define the limitations in the process analysis. The last three activities include defining the environment (whose task is to identify sources of information on all technical, legal, organizational, and human circumstances relevant to the activities and problem to be analyzed), condition assumptions, and finally the analysts should identify decisions that will be adopted, the way the study will be presented.

Risk assessment is performed for each incident situation, by determining the appropriate risk for a given scenario or technical process, as a function of the severity of the possible damage and the probability of its occurrence [5, 6].

The methods used in risk assessment are often quantitative, although the degree of detail required to prepare an assessment depends on the specific application. Frequency analysis is used to estimate the probability of each identified adverse event

A complete quantitative assessment is not always possible in case of lack of information about the system or activities they analyze, incomplete data on failures, the influence of the human factor, etc. Some risk elements cannot be quantified by the probability of distribution. Their significance is then assessed quantitatively by considering the nature of what is being protected (humanity, the environment), the severity of the injuries or damage, or the degree of damage. It should also be noted that the magnitude of the damage may be defined differently depending on the situation. Consequence analysis assesses the probabilities of impact if an adverse event occurs. Assess the impact on people, the environment or property. The consequences of different types of risk are generally expressed in terms of safety, health, financial, and environmental terms.

Risks in industry insurance are property risks. However, in addition to basic and additional property risks, there are some very specific risks.

The basic risks can be: risks of fire and lightning, explosion, storm and hail, impact of own motor vehicle and own mobile working machine in the insured construction object, plane crash, manifestation and demonstration, earthquake.

Ancillary risks represent those risks that do not threaten every type of property, these risks threaten only the only property due to either the nature of the property itself or the place where that property is located. Additional risks include: floods and torrents, landslides and landslides, liquid and gas leaks, water spills from installations, self-ignition of stocks [2, 5].

### **Risk of fire and some other hazards**

Fire risk is considered basic, not only in property insurance, but also in insurance in general. The conclusion of many other types of insurance is conditioned by the prior conclusion of fire insurance as the basic insurance. Needless to say, the consequences of realizing this risk can be catastrophic. From this fact, this risk is almost always insured

### **Workplace risk**

Occupational risk (R) is most often defined as the product of the probability of occurrence of a risk events (Prd) and the severity of its consequences (Cp):  $R = Prd \cdot Cp$ . The severity of the consequences depends on the type of hazard or harm that can cause an injury at work, an occupational disease or an occupational disease.

During the functioning of technological systems, workers are exposed to various influences and actions that are a consequence of technological processes and operations in them. Also, since it is practically impossible to eliminate the occurrence of danger or harm, to build trouble-free and perfectly ergonomic means of work, it is necessary to choose such an organization of the technological process that respects working conditions, initial risk factors, contains measures, procedures and means to eliminate or reduce unwanted events.

Occupational risk management does not mean eliminating risk, but reducing the risk of the system to an acceptable level. If the risk of the work environment system is acceptable, the work environment is considered safe, ie. an environment that in certain operating conditions maintains such a state in which risky events caused by the action of danger or harmful factors on unprotected elements of the system and environment are excluded with a given probability, and damage from inevitable emissions of material and energy resources does not exceed the allowed value.

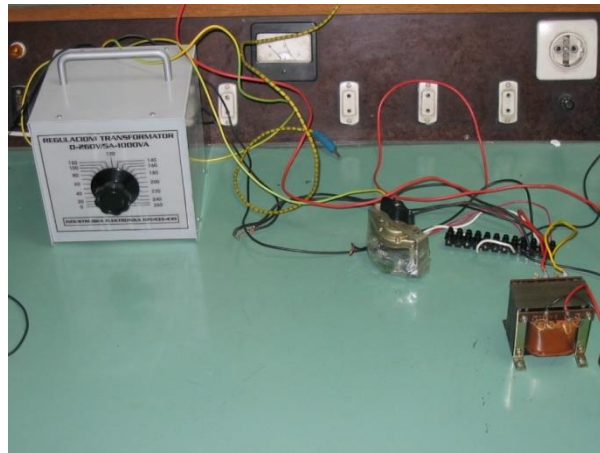
According to the law on safety and health at work, work equipment includes machines, devices, plants, installations, tools and the like, which are used in the technological process. Mechanical hazards that occur with the use of hand tools (shovels, axes, knives, keys, levers, saws, hammers, etc.) occur due to the characteristics of operations, misuse, improper maintenance and poor storage. Mechanical hazards that occur with the use of work equipment, and arise from the action of mechanical tools, production machines, devices and their components that move or stop (gears, belts, various levers, tools, transmission chains, etc.), and are the cause their linear and rotational motion [5, 7].

Special attention should be paid to the analysis of mechanical hazards that occur in industrial and public transport. The technological connection between industrial transport and public transport is that a large part of the function of public transport is realized by external industrial transport.

### **Risk of fracture and some other hazards**

The risk of breakage and other hazards primarily means the risks of damage or destruction of machines due to an accident in the plant. This does not include the destruction or damage of all types of tools used for processing materials, clamping accessories, parts of the machine that are directly used for breaking and grinding, etc. [3, 5]

The specificity of the risk of fracture is reflected in the error in construction, material and construction, direct action of electric current, decomposition due to centrifugal force, lack of water in steam boilers and steam appliances, except in cases of explosion, frost, ice or snow pressure, or direct movement of ice (Fig. 1).



**Fig. 1.** Testing of electrical machines

### **Risks of liability from the activity**

Performing a professional activity, it is possible to cause damage to someone's belongings by destruction or damage, ie damage to health, injury or death of a person. This is actually a risk of negligence and error in performing an activity [2, 3].

### **Product liability risks**

These risks occur with warranty insurance for which the insured is liable during the warranty period, and which are the result of a defect or defect in the insured item itself, as follows:

- construction errors, material errors, ie production errors and incorrect technical-calculation calculations,
- malfunctions and errors made in the workshop or assembly.

This risk is covered only during the warranty period from the contract of sale of the item. This type of insurance is not only characterized by specificity in economics and risk assessment techniques. The problem is also in the risk covered by the guarantee insurance. In order to conclude a contract on this insurance, it is necessary that there is a strong mutual trust and attention of the contracting parties. Otherwise, the insurance of this producer risk provides opportunities to include in the insurance only the most serious risks, often insufficiently tested products [1,3].

### **Risk of interruption of work due to the realization of some basic risk**

In case of realization of some insured basic property risk, there is a direct damage to the insured thing, but if that damage can cause the termination of a company or its significant reduction, then we have an indirect loss that caused the realized risk. These are losses of property interest such as income, gross profit, as well as certain operating costs of the insured in case of work interruption due to fire and some other dangers.

Income means only that income which is realized by performing a registered economic activity as well as income related to that activity.

Costs include only those costs that are of a fixed nature and arise regardless of whether the economic activity takes place or not. Costs that are directly related to the performance of economic activity (eg, production) such as costs of raw materials, consumed energy, etc. they cannot be the subject of insurance [2, 7].

The risk of interruption of work is considered to be the risk caused by the basic risks.

### **CONCLUSION**

Through the risk management process, the organization protects its interests as well as the interests of its business environment, the environment and the community in which it operates. Defining

responsibility for risk management for each manager and each employee greatly contributes to achieving the goals of risk management. This raises operational efficiency at all levels of a particular enterprise.

The risk management process provides economic and legal protection as well as a basis for decision making.

Risk management should cover all risks related to: past activities, current activities and especially future activities. Likewise, risk management should be integrated into the culture of the organization along with an effective policy and program.

## **REFERENCES**

- [1] Prasanta, K. D.: Decision support system for risk management: a case study, *Manag. Deci.* 39, pp.634-649, 2001.
- [2] Kirin, S., Đorđević, P., Sedmak, A.: Risk management in Structural Integrity – Application to a large company, *Structural Integrity and Life*, 11, pp.209-213, 2011.
- [3] Michael, I., Wiggins, P.E.: Risk analysis, The University of Oklahoma, Oklahoma, 1984.
- [4] Đorđević, P., Kirin, S., Sedmak, A., Džindo E.: Risk analysis in structural integrity, *Structural Integrity and Life* 11, pp.135-138, 2011.
- [5] Kirin S.: Risk management in modern industrial systems, Doctoral thesis, FTN, University of Novi Sad, 2011.
- [6] Kirin, Ž., Grubić-Nešić, L., Kirin, S.: Risk management in the energy sector balances government risk, *Strategic Management, Strategijski menadžment* 12, pp.121–127, 2007.
- [7] Rakonjac, I., Kirin, S., Spasojevic-Brkic, V., Sedmak A.: Risk analysis by key-coefficient assessment – Public lighting project example, *Tech. Technol. Educ. Ma.* 6, pp.1016-1024, 2011.

## STABLE INSTALLATIONS FOR FIRE PROTECTION ON THE FACILITY OF THE PRIMARY SCHOOL "STANČIĆ MILAN - UČA", KUMANE

Dragana Milosavljev<sup>1</sup>, Edit Terek<sup>1</sup>, Maja Gaborov<sup>1</sup>, Borivoj Novaković<sup>1</sup>

<sup>1</sup>University of Novi Sad, Technical Faculty "Mihajlo Pupin", Zrenjanin, Serbia

e-mail: [milosavljevd@yahoo.com](mailto:milosavljevd@yahoo.com)

**Abstract:** Risks are something we face every day. One of the most common risks that affect humans is fire, which is why the importance of fire protection is emphasized. Fire protection is extremely important in order, above all, to save human lives, but also to protect property from destruction and damage. In this paper, the concept of fire risk is explained; fire protection methods are explained, as well as fire protection systems. In the further course of work, one can see the calculation of the fire risk for the building of the Elementary School "Stančić Milan - Uča", Kumane (Republic of Serbia) and giving proposals for the development of a project for the installation of fire detection and alarm systems.

**Key words:** risk, fire, fire protection, stable installations

### INTRODUCTION

Risk is a term that is associated with the occurrence of an economically harmful event, which means that it poses a danger to people's lives, but also to their property. One of the basic risks that occur in people's lives are fires. Fire is an uncontrolled combustion of matter, which endangers the health and safety of people and material goods [1]. Three conditions are necessary for the occurrence of a fire: fuel (it can be any flammable substance), oxidizer - oxygen and heat (energy that is necessary to increase the temperature of the fuel to the point where it ignites) [2]. Fire protection implies a detailed analysis and study of fire and its accompanying effects, as well as the development, testing and application of adequate protection systems. Today, very large and expensive facilities are being built in the world in which a large number of people live or work, and for that reason these facilities require special security measures. Fire risk assessment is an assessment of fire risk or level of fire safety of the user of the facility, its property, and is achieved by designing fire safety based on the performance of the facility [3]. Basic methods of fire protection are divided into: active, passive fire protection and preventive-educational fire protection [1]. During the year, the most developed methods of active fire protection, i.e. automatic systems for fire detection, alarm and extinguishing. These systems are most often used in public facilities, as well as in facilities used for the production and storage of flammable substances. Depending on the purpose of the facility, it is chosen whether the system will also include devices for automatic fire extinguishing or only fire detection and alarm. When it comes to public facilities (schools, health facilities, theaters, cinemas, department stores, etc.) and high-rise residential buildings, it is mandatory to install devices that allow early detection and occurrence of fires [4]. The paper presents the calculation of fire risk, through the calculation of fire risk of the building structure and fire content of the building, where for the building of the Elementary School "Stančić Milan Uča" from Kumane it is proposed to design and install an automatic system for fire detection and alarm.

### FIRE RISK AND FIRE PROTECTION

#### The concept of fire risk

The International Organization for Standardization has defined risk as a combination of the probability of an event and its consequences [5]. The risk itself is identified with the occurrence of an economically harmful event, such as: fire, collision, explosion, robbery, theft. The risk calculation can be represented by the following formula:

$$R = P \times C \quad (1)$$

Where: R - risk, P - probability of risk occurrence and C - consequences of risk manifestation.

Fire risk is one of the basic risks that occur in human lives. It is a process of uncontrolled combustion of substances, which endangers human health and safety, environmental pollution and destruction of material goods [1]. By applying the Euroalarm procedure for calculating the fire risk, two parameters are determined: the fire risk of the building structure and the fire risk of the building contents. Based on the size of the fire risk, the justification of installing a fire alarm and extinguishing system is determined [6]. The fire risk of the construction of the building depends on the possible intensity and duration of the fire, as well as on the structural characteristics, load-bearing elements of the building, and is calculated using the following form:

$$R_o = \frac{[(P_o \times C) + P_k] \times B \times L \times S}{W \times R_i} \quad (2)$$

Where:  $R_o$  - fire risk of building construction;  $P_o$  - fire coefficient of mobile fire load;  $C$  - coefficient of combustibility of the object content;  $P_k$  - coefficient of fixed fire load,  $B$  - coefficient of size and position of the fire sector;  $L$  - coefficient of delay in the start of extinguishing;  $S$  - fire sector width coefficient;  $W$  - coefficient of fire resistance of the structure;  $R_i$  - fire risk reduction coefficient.

The fire risk of the contents of the facility, which refers to the danger to people, furniture, equipment, goods, etc., is calculated on the basis of the form:

$$R_s = H \times D \times F \quad (3)$$

Where:  $R_s$  - fire risk of the contents of the facility;  $H$  - coefficient of danger for people;  $D$  - asset risk ratio;  $F$  - coefficient of smoke action.

A quality fire risk assessment is an assessment that involves numerical quantification and the probability of a fire, as well as the consequences that a fire would bring. The more precisely the risk assessment is performed, the less the damage will be reduced if a risk event occurs.

### Fire protection methods

Fire protection includes a set of measures and actions of normative administrative, organizational-educational and other nature, and is organized and implemented in all places and facilities that are exposed to fire hazards [7]. The Law on Fire Protection envisages measures, actions and procedures that should be taken in order to prevent the occurrence of a fire or, if a fire occurs, in order to reduce its consequences [8]. Fire protection methods are divided into [9]:

- preventive and educational protection (design of the facility, training and education of the users of the facility on fire protection, posters of fire protection actions);
- passive protection (fireproof walls, floors, doors, escape routes, fire stairs) and
- active protection (mechanical and automatic fire extinguishing systems).

Public, post-residential or residential buildings, in which a large number of people live, are largely exposed to the risk of catastrophic consequences, especially the risk of fire. Fire safety is often implied in the design and construction of buildings, as well as the renovation of existing buildings [10]. The assessment of the risk of fire or the level of fire safety of the user of the facility is an analysis and evaluation of the applied preventive measures, which are designed based on the performance of the facility. Based on the national technical regulations in the Republic of Serbia, the fulfillment of the minimum technical requirements for fire safety during the design, construction and operation of the building is mandatory [11].

### STABLE FIRE PROTECTION INSTALLATIONS

Stable installations for fire protection are systems for detection, alarm, i.e. fire alarm and fire extinguishing, as well as detection of explosive gases and heat dissipation systems. The time of fire detection and the beginning of its extinguishing is directly related to the damage that will occur due to the effects of fire, and especially due to the loss of human lives [3]. When it comes to public facilities (schools, health care institutions, cinemas, department stores, etc.) and high-rise residential buildings, it is mandatory to install devices that enable early detection and occurrence of fires. The fire detection, alarm and extinguishing system should provide early detection of fire inside the building, to adequately warn everyone in the building and to start extinguishing the fire [13]. Stable installations for fire detection, alarm and extinguishing consist of the following elements [7]:

- control panels for automatic fire alarm - electronic devices that supply and control other elements of the system;
- fire detectors - detect fire through their sensors. They can be manual and automatic;
- signaling devices - alarm systems, bells, lamps, flashes;
- devices for managing executive functions - lowering elevators, switching on the smoke system, closing fire dampers;
- sprinkler fire extinguishing systems - stable water extinguishing installations are most often used;
- electrical installations for connecting these elements - energy sources must be connected with rigid fixed connections to the system of stable installation, so that the failure of one of the sources would not cause interference with the other source.

## FIRE PROTECTION SYSTEM ON THE FACILITY OF THE PRIMARY SCHOOL "STANČIĆ MILAN - UČA", KUMANE

Elementary school "Stančić Milan - Uča" is located in Trg slobode 4, in Kumane, where the main entrance to the building is. The Voluntary Fire Brigade "Brusin Sredoje" is in the immediate vicinity of the school. The total area of the building is 2458.68 m<sup>2</sup>, which consists of a basement, ground floor with hall and two floors. There are two entrances to the building and a staircase is designed at both entrances. The basement extends below the school building and consists of the following rooms: hydrophore room; kitchen with dining area; janitor's workshop and cabinet for technical education and informatics. The basement can be accessed by two internal stairs from the hallway. The ground floor of the building is irregular in shape and consists of the following rooms: four classrooms; sanitary facilities for students; hallway; basement and first floor stairs; hall with windshield and stage; space behind the stage; passage to the kindergarten premises; offices; chamber office; sanitary facilities for employees; storage room; archive; porter's room and boiler room. The following rooms are located on the first and second floor: stairs; hallway; four classrooms; a room for non-teaching staff and a toilet for pupils.

Using the Euroalarm method, according to formula (2), the calculation of the fire risk of the building is performed.  $P_o$  - the fire load coefficient is determined according to the purpose of the building. For schools, according to the data from the Euroalarm table, the purpose of the building is 251 MJ/m<sup>2</sup> and it belongs to class IV fire danger [13], so from Table 1 it can be seen that  $P_o$  is 1.0.

**Table 1.** Coefficient of fire content [6]

Degree of danger	kg of wood / m <sup>2</sup>	MJ/m <sup>2</sup>	$P_o$
1	0-15	0-251	1.0
2	16-30	252-502	1.2
3	31-60	503-1004	1.4
4	61-120	1005-2009	1.6
5	121-240	2010-4019	2.0
6	241-480	4020-8038	2.4
7	481-960	8039-16077	2.8
8	961-1920	16078-32154	3.4
9	1921-3840	32155-64309	3.9
10	>3841	64310	4.0

C –the coefficient of combustibility of the contents in the building is taken according to the class of fire danger, i.e. class IV, and from Table 2 it can be seen that C is 1.0.

**Table 2.** Combustion coefficient in relation to the hazard class [6]

Degree of danger	Fire hazard class	C
1	VI	1.0
2	V	1.0

3	IV	1.0
4	III	1.2
5	II	1.4
6	I	1.6

$P_k$  – the coefficient of fire load of materials installed in the structure for 251 MJ/m<sup>2</sup>, and according to the table of fire resistance of building structures, is 0, which can be seen in Table 3.

**Table 3.** Coefficient of fire load of materials installed in the construction of the building [6]

Degree of danger	kg of wood / m <sup>2</sup>	MJ/m <sup>2</sup>	$P_k$
1	0-25	0-419	0
2	26-50	435-837	0.2
3	51-100	845-1675	0.4
4	101-250	1691-4187	0.6
5	251-500	4203-8373	0.8

B – the coefficient of size and position of the fire sector for an area of 2458.68 m<sup>2</sup>, two floors and a basement represents the II degree of danger and is 1.3., which is shown in Table 4.

**Table 4.** Fire sector coefficient [6]

Degree of danger	Object characteristics	B
1	- fire sector up to 1500 m <sup>2</sup> - room height up to 10 m - maximum 3 floors	1.0
2	- fire sector 1500-3000 m <sup>2</sup> - 4-8 floors - room height 10-25 m - one floor in the basement	1.3
3	- fire sector 3000-10000 m <sup>2</sup> - more than 8 floors - room height over 25 m - more than 2 floors in the basement	1.6
4	- fire sector over 10000 m <sup>2</sup>	2.0

L – the coefficient of delay in starting the extinguishing, as the Voluntary Fire Brigade, as a territorial voluntary unit without a permanent duty, needs from 20 to 30 minutes to start extinguishing the fire, according to Table 5 it can be seen that L is 1.6.

**Table 5.** Coefficient of delay in the beginning of extinguishing a fire brigade [6]

	Starting extinguishing the fire	10'	10-20'	20-30'	30'
	Distance	1km	1-6 km	6-11 km	11 km
Type of fire brigade	Professional industrial unit	1.0	1.1	1.3	1.5
	Voluntary industrial unit	1.1	1.2	1.4	1.6
	Territorial professional unit	1.0	1.1	1.2	1.4
	Territorial voluntary unit with permanent duty	1.1	1.2	1.3	1.5
	Territorial voluntary unit without permanent duty	1.3	1.4	1.6	1.8

S – the coefficient of width of the fire sector is 1.1., which is shown in Table 6.



**Table 6.** Fire sector width coefficient [6]

Minimum width of the fire sector (m)	Fire sector width coefficient <i>S</i>
Up to 20	1.0
20-40	1.1
40-60	1.2
over 60	1.3

W – the coefficient of fire resistance of the load-bearing structure of the building was obtained on the basis of the standard fire resistance (the material from which the building was built). This building is according to the type of construction F60 (the part of the building to which the label refers will not collapse, nor will the fire be transferred from that part of the building for up to 60 minutes). From Table 7 it can be concluded that the coefficient of fire resistance of the building is 1.5.

**Table 7.** Coefficient of resistance of load-bearing structure [6]

Fire resistance (min)	kg of wood / m <sup>2</sup>	MJ/m <sub>3</sub>	W
Up to 30	-	-	1.0
30	37	619	1.3
60	60	1004	1.5
90	80	1339	1.6
120	115	1925	1.8
180	155	2595	1.9
240	180	3014	2.0

R<sub>i</sub> – the fire risk reduction coefficient is in accordance with the expected development of fires normal and is 1.3, which is shown in Table 8.

**Table 8.** Fire risk reduction coefficient [6]

Risk assessment	Circumstances affecting risk assessment	R <sub>i</sub>
The biggest	<ul style="list-style-type: none"> <li>- high flammability of the material and storage with larger gaps</li> <li>- rapid spread of fire is expected</li> <li>- there are a number of possible ignition sources in the technological process or during storage</li> </ul>	1.0
Normal	<ul style="list-style-type: none"> <li>- flammability is not extremely high, and storage is at a distance that allows manipulation</li> <li>- normal speed of fire spread is expected</li> <li>- there are normal ignition sources in the technological process or during storage</li> </ul>	1.3
Smaller than normal	<ul style="list-style-type: none"> <li>- lower flammability - partial storage (25-50%) of flammable goods in non-combustible packaging</li> <li>- storage of flammable goods without gaps</li> <li>- rapid spread of fire is not expected</li> <li>- for ground floor halls with an area of less than 3000 m<sup>2</sup></li> <li>- for a building where there is smoke and heat removal</li> </ul>	1.6
Slight	<ul style="list-style-type: none"> <li>- low probability of ignition due to goods in boxes made of sheet metal or other similar materials, as well as from very dense storage</li> <li>- very slight development of fire is expected</li> </ul>	2.0

Based on the obtained results, it can be seen that the fire risk of the building is:

$$R_o = \frac{[(1.0 \times 1.0) + 0] \times 1.3 \times 1.6 \times 1.1}{1.5 \times 1.3} = 1.1733$$

The fire risk of the contents of the building is calculated according to formula (3). The H-hazard coefficient for people depending on the timely evacuation for this facility is 2.0, which is shown in Table 9.

**Table 9.** Coefficient of danger to humans [6]

Type of threat	H
No danger to persons	1.0
There is danger for people, but they can save themselves	2.0
There is a danger for people, and evacuation is difficult (very smoky, large number of people, multi-storey building, rapid development of fire, the presence of immobile people, the sick, children, the elderly)	3.0

D – the property value ratio is 1.0, because the value of the property is not large and prone to destruction (Table 10).

**Table 10.** Asset value ratio [6]

Concentration of values	D
The contents of the object are of little value or little prone to destruction	1.0
The content represents a value of \$ 400 / m <sup>2</sup> or \$ 300,000 per fire sector and is prone to destruction	2.0
The loss is irreparable (cultural goods, etc.) or the destruction indirectly endangers the existence of the population (loss greater than 400 USD / m <sup>2</sup> or 300000 USD per fire sector)	3.0

F – the smoke coefficient is 1.5, which means that more than 20% of the total weight of combustible substances cause smoke, which is shown in Table 11.

**Table 11.** Smoke hazard ratio [6]

Circumstances leading to smoke	F
There is no special danger of smoking and corrosion	1.0
More than 20% of the total weight of all combustible substances cause smoke or emit toxic combustion products or the rooms are without windows	1.5
More than 50% of the total weight of all combustible substances consists of materials that create smoke or emit toxic combustion products or more than 20% of the total weight of all combustible substances consists of materials that emit highly corrosive gases	2.0

According to the obtained data, it can be concluded that the fire risk of the contents of the facility is:

$$R_s = H \times D \times F = 3$$

Based on the obtained values for  $R_o$  (fire risk of building construction) and  $R_s$  (fire risk of the content of the building), the data obtained on the Fire Risk Diagram (*Chart 1*) is given, from which it can be seen whether and which system needs to be installed. The fields on the diagram shown have the following meanings [3]: A - the risk is very small, so preventive measures are sufficient; B - as a rule, automatic fire extinguishing and alarm systems are not required; C - installation of a fire alarm system is not justified, but an automatic fire extinguishing system is required; D - a fire alarm system is required; E - double protection is recommended for fire alarm and extinguishing systems (E1 - fire extinguisher required, E2- fire alarm device required); F - mandatory installation of fire extinguishing systems and fire alarm systems. According to the Fire Risk Diagram, it can be concluded that fire alarm systems need to be installed in the building of the Elementary School "Stančić Milan - Uča".

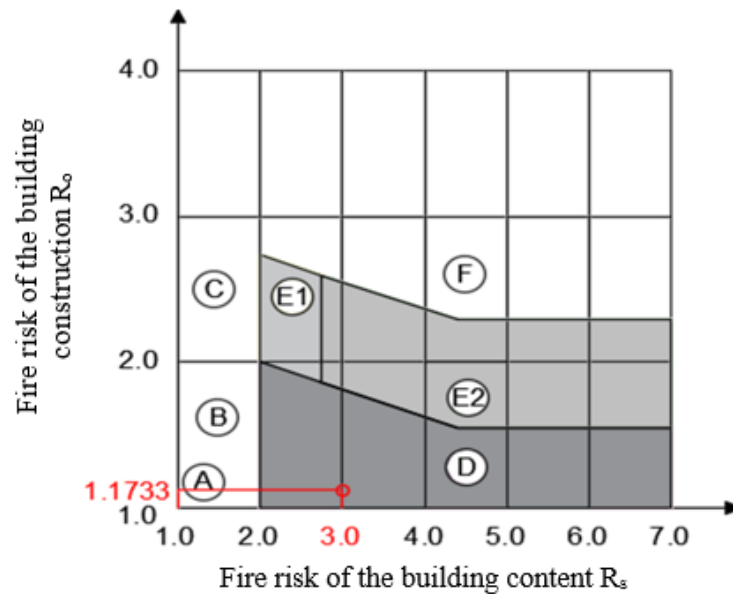


Fig. 1. Fire risk diagram for the school building

The installation of the following elements of stable installations for fire detection and alarm is proposed in the building of the Primary School: fire control panels, automatic fire detectors, manual fire detectors and fire alarms (audio/visual). A stable installation for fire detection and reporting should cover the entire facility, except for rooms where technical control measures are not mandatory, ie except for wet facilities.

## CONCLUSION

The main goal of fire protection is to prevent its occurrence, and if a fire occurs, to reduce it to an acceptable level, as well as to reduce the probability of deaths, injuries and material losses. In order to meet this goal, it is necessary to perform a good risk assessment and on the basis of it choose the appropriate way of fire protection. One of the methods of fire protection is active fire protection, which involves the use of a system for automatic detection, notification and extinguishing of fire. These systems should provide early detection of fires inside the building, and to adequately warn everyone in the building of the occurrence of fires and to start extinguishing fires.

It is known that schools and other public facilities in rural areas have been neglected in terms of fire protection. Most of these buildings are older and have a higher fire risk, and almost no fire protection. Automatic fire protection systems, if they exist, are usually outdated and/or not adequately maintained. In order to protect such facilities from fire, it is necessary to invest certain funds in the design and installation of modern automatic fire protection systems, to train certain persons who would manage these systems and to regularly service the systems.

Further research in the field of fire protection should go in two directions. The first direction would refer to the construction of buildings, i.e. the selection of materials for the construction of buildings. The materials that would be used for the construction of buildings should have a lower degree of flammability, which would reduce the fire load of the building. Also, by using renewable energy sources, such as solar panels, heat pumps, etc. instead of the classic types of heating systems, the risk of fire outbreaks in buildings would be reduced. The second direction should be directly related to the improvement of automatic fire protection systems. Detectors, as one of the key elements of the system, on whose sensitivity and speed of detection further operations should be improved. Smoke detectors, in addition to smoke, also react to other particles, by improving these detectors in terms of their sensitivity, i.e. the recognition of smoke particles, the number of false alarms would be significantly reduced. What would make it easier to install and maintain these systems is a complete transition to wireless systems. This move would also save a lot of money. Also, it is necessary to work on the improvement of the fire extinguishing system, in terms of finding new substances that would

extinguish the fire, and which would cause the least possible damage to people and material goods that are in the building.

## REFERENCES

- [1] Milosavljev, D., Novaković, B., Kavalić, M., Stanisavljev, S.: Menadžment rizikom putem preventivnog i reaktivnog delovanja automatskih sistema za gašenje požara. 15. Međunarodna konferencija Rizik i bezbednosni inženjering. pp. 358-363, Republika Srbija, Kopaonik, 2020.
- [2] Visoka tehnička škola strukovnih studija, Novi Sad: Obuka iz zaštite od požara. Interna skripta. <http://vtsns.edu.rs/wp-content/uploads/2018/02/OBUKA-studenata-ZOP.pdf>
- [3] Laban, M., Čosić Đ., Bondžić, J., Novaković, T.: Osnove upravljanja rizikom od katastrofalnih događaja i požara, Univeritet u Novom Sadu, Fakultet tehničkih nauka, Novi Sad, 2017.
- [4] Sekulović Z., Bogner M., Pejović S.: Preventivna zaštita od požara, Eta, Beograd, 2012.
- [5] ISO 31000 Risk Management: <https://www.iso.org/iso-31000-risk-management.html>
- [6] Blagojević, M.: Projektovanje i održavanje sistema za dojavu požara – Metodi za procenu rizika, Univerzitet u Nišu, Fakultet zaštite na radu u Nišu, Niš, 2015.
- [7] Erić, M.B.: Protivpožarna i preventivno-tehnička zaštita. Inženjersko-tehnički priručnik. Jel&Mil, Čačak, 2003.
- [8] Vatrosafe, Zaštita od požara: <http://vatrosafe.rs/zastita-od-pozara/>
- [9] Milosavljev, D., Kavalić, M., Terek, E., Stanisavljev, S., Milanov, D.: A brief study on fire protection systems, IIZS 2019., pp. 539-544, Republika Srbija, Zrenjanin, 2019.
- [10] Laban, M., Popov, S., Vukosavljević, S., Šupić, S.: Performanse puteva evakuacije i bezbednost zgrada od požara. Tehnika – Naše graševinarstvo, Vol. 6, No. 4, pp.599-606, 2015.
- [11] Tehno Vinča, Tehnička zaštita objekata, Automatsko gašenje požara: <http://tehnovinca.com/sr/stabilina-instalacija-za-automatsko-gasenje-pozara.html>
- [12] Almaks – Zakoni i propisi, Stabilne instalacije za dojavu požara: [https://almaks.rs/wp-content/uploads/stabilni\\_sistemi\\_-\\_stabilne\\_instalacije\\_za\\_dojavu\\_pozara.pdf](https://almaks.rs/wp-content/uploads/stabilni_sistemi_-_stabilne_instalacije_za_dojavu_pozara.pdf)
- [13] Tabela podela objekta prema nameni, Veličina požarnog opterećenja, klase opasnosti, zadimljenje i koroziione pare u zavisnosti od tehnološkog procesa [http://www.ppz.rs/pdf/2009/Tabela\\_-\\_Podela\\_objekata\\_prema\\_nameni.pdf](http://www.ppz.rs/pdf/2009/Tabela_-_Podela_objekata_prema_nameni.pdf)